



VILLAGE OF VILLA PARK

CONTRACT DOCUMENTS

FOR

**SECOND AVENUE COMBINED SEWER SEPARATION
PROJECT**

JUNE 15, 2018

PREPARED BY

CHRISTOPHER B. BURKE ENGINEERING, LTD.

NOTE: FEDERAL LABOR STANDARDS, PREVAILING WAGE RATES, AND SECTION 3 REGULATIONS WILL APPLY TO THIS PROJECT.

MINORITIES AND WOMEN OWNED BUSINESSES (MBE/WBE) ARE ENCOURAGED TO SUBMIT BIDS ON THIS PROJECT.

NOT FOR BID

**ADVERTISEMENT FOR BIDS
VILLAGE OF VILLA PARK
FRIDAY, JUNE 15, 2018**

PROJECT: SECOND AVENUE COMBINED SEWER SEPARATION PROJECT

This project consists of installing approximately 1,050 linear feet of storm sewer varying in size from 12" to 36". The project also includes pavement removal, aggregate base course, Hot-Mix Asphalt Binder Course, Hot-Mix Asphalt Surface Course, curb and gutter removal and replacement, sidewalk removal and replacement, driveway pavement removal and replacement, adjusting sanitary services, adjusting water services, and landscape restoration.

BID DEADLINE: TUESDAY, JULY 10, 2018, 10:00 A.M. LOCAL TIME

The Village reserves the right to extend the Bid Deadline from this date and time to accept Bids submitted after the Bid Deadline, as the Village, in its sole discretion, determines is in the best interest of the Village.

NOTICE: Separate, sealed proposals for the **SECOND AVENUE COMBINED SEWER SEPARATION PROJECT** will be received by the Village of Villa Park, Illinois, at the reception desk of the Public Works Department, 11 West Home Avenue, Villa Park, Illinois, 60181, until the Bid Deadline. Immediately thereafter, the proposals will be publicly opened and read aloud at the offices of the Public Works Department. Notwithstanding the foregoing, the Village reserves the right to defer, postpone, delay, or reschedule the Bid Opening for such time and to such date as the Village, in its sole discretion, determines is in the best interest of the Village.

Proposals shall be submitted in accordance with the Bidding Documents prepared by Christopher B. Burke Engineering, Ltd., 9575 W. Higgins Road, Rosemont, IL 60018.

Minority and Women Owned Businesses (MBE/WBE) are encouraged to submit bids on this project. Federal Labor Standards and Prevailing Wage Rates apply to this Project.

BIDDER QUALIFICATIONS: Bidders, in submitting a Bid, shall comply with all applicable Federal, State and Local laws and requirements; shall provide documentation of that compliance in accordance with the requirements of the Contract Documents or as requested by the Village; and, in submitting a Bid, Bidders affirm that they are qualified under all applicable laws and requirements to do so, and agree to be bound by the determination of the Village as to Bidder's compliance and qualifications.

MANDATORY PRE-BID MEETING: A mandatory pre-bid meeting for contractors interested will be held on June 26, 2018 at 10:00 a.m. at the Village of Villa Park Public Works Department, 11 West Home Avenue, Villa Park, Illinois, 60181. Village and Consulting engineering staff will be on hand to answer questions regarding interpretations of the project plans and specifications and discuss project scheduling. If required, a project addendum will be prepared based upon questions raised by the

bidding community and distributed to all attendees for inclusion within their respective bids. It will be the Village's decision whether bids are opened from Contractors that do not attend the mandatory pre-bid meeting.

BID SECURITY: Bid security in the amount of not less than five percent (5%) of the Bid shall accompany each Bid in accordance with the Bidding Documents.

CONTRACT SECURITY: The Bidder to whom a Contract is awarded shall be required to furnish both a Performance Bond and a Payment Bond acceptable to the Village for one-hundred percent (100%) of the Contract Price, in accordance with the requirements of the Contract Documents.

RIGHTS RESERVED: The Village will select the lowest, most responsible bidder. The Village reserves the right to reject any and all Bids, to waive any informalities or technicalities in bidding, and to accept the Bid which best serves the interests of the Village. The Village shall, in its sole discretion, determine what does or does not constitute an informality or technicality, and, in submitting a Bid, Bidder agrees to be bound by that determination.

The Village may make such investigations as it deems necessary to determine the ability of the Bidder to perform the Work, and the Bidder shall furnish to the Village all such information and data for this purpose as the Village may request. The Village reserves the right to reject any Bid if the evidence submitted by, or investigation of, such Bidder fails to satisfy the Village that such Bidder is properly qualified to carry out the obligations of the Agreement and to complete the Work contemplated therein.

WAGE RATES: All applicable laws, ordinances, and the rules and regulations of all authorities having jurisdiction over construction of the PROJECT shall apply to the contract throughout.

This project is partially paid for with Federal grant funding through the Community Development Block Grant Program. Davis-Bacon Wage Decisions also apply and are only superseded in instances by and where Illinois Prevailing Wages exceeds Davis-Bacon in wage, fringe benefits, and/or trade stipulations (requirements). If this project does not start within 90 days of award, the wage determinations shall be replaced with the most current decisions.

NON-DISCRIMINATION CLAUSE: All contracts between the Subgrantee and the Contractor and all subcontracts thereafter must include the following non-discrimination clause: "Employers shall not discriminate against employees or applicants for employment on basis of race, color, religion, sex, national origin, age, familial status, or disability."

CONTRACT DOCUMENTS: The Bidding Documents are on file for inspection at the office of the Village of Villa Park Public Works Department, 11 West Home Avenue, Villa Park, Illinois, 60181, and may also be obtained from the Village of Villa Park Public Works Department at the address listed above for a non-refundable fee of twenty dollars (\$20.00).

PUBLISHED BY AUTHORITY OF THE VILLAGE OF VILLA PARK, DUPAGE COUNTY, ILLINOIS.

BY: *Vydas Juskeles*
Vydas Juskeles, P.E.
Director of Public Works

NOT FOR BID

NOT FOR BID



**Illinois Department
of Transportation**

**Local Public Agency
Formal Contract
Proposal**

PROPOSAL SUBMITTED BY		
Contractor's Name		
Street	P.O. Box	
City	State	Zip Code

STATE OF ILLINOIS

COUNTY OF DUPAGE
VILLAGE OF VILLA PARK
 (Name of City, Village, Town or Road District)

FOR THE IMPROVEMENT OF
 STREET NAME OR ROUTE NO. SECOND AVENUE
 SECTION NO. N/A
 TYPES OF FUNDS CDBG-DR/LOCAL

SPECIFICATIONS (required)

PLANS (required)

NOT FOR BIDDING

Note: All proposal documents, including Proposal Guaranty Checks or Proposal Bid Bonds, should be stapled together to prevent loss when bids are processed.

NOT FOR BID

RETURN WITH BID

NOTICE TO BIDDERS

County DUPAGE
Local Public Agency VILLA PARK
Section Number N/A
Route SECOND AVENUE

Sealed proposals for the improvement described below will be received at the office of PUBLIC WORKS DEPARTMENT, 11 WEST HOME AVENUE, VILLA PARK, ILLINOIS 60181 until 10:00 AM on July 10, 2018

Sealed proposals will be opened and read publicly at the office of PUBLIC WORKS DEPARTMENT 11 WEST HOME AVENUE, VILLA PARK, ILLINOIS 60181 at 10:00 AM on July 10, 2018

DESCRIPTION OF WORK

Name SECOND AVENUE COMBINED SEWER SEPARATION PROJECT Length: 1103 feet (0.21 miles)
Location SECOND AVENUE BETWEEN HOLLY COURT AND DIVISION STREET
Proposed Improvement STORM SEWER INSTALLATION, PAVEMENT RECONSTRUCTION, CURB AND GUTTER R&R, SIDEWALK R&R, WATER AND SANITARY SERVICE ADJUSTMENTS, AND PARKWAY RESTORATION.

1. Plans and proposal forms will be available in the office of VILLAGE OF VILLA PARK PUBLIC WORKS FOR \$20 NON-REFUNDABLE FEE 11 WEST HOME AVENUE, VILLA PARK, ILLINOIS 60181, PHONE: (630) 834-8505

2. [] Prequalification

If checked, the 2 low bidders must file within 24 hours after the letting an "Affidavit of Availability" (Form BC 57), in duplicate, showing all uncompleted contracts awarded to them and all low bids pending award for Federal, State, County, Municipal and private work. One original shall be filed with the Awarding Authority and one original with the IDOT District Office.

3. The Awarding Authority reserves the right to waive technicalities and to reject any or all proposals as provided in BLRS Special Provision for Bidding Requirements and Conditions for Contract Proposals.

4. The following BLR Forms shall be returned by the bidder to the Awarding Authority:

- a. BLR 12200: Local Public Agency Formal Contract Proposal
b. BLR 12200a Schedule of Prices
c. BLR 12230: Proposal Bid Bond (if applicable)
d. BLR 12325: Apprenticeship or Training Program Certification
e. BLR 12326: Affidavit of Illinois Business Office

NOT FOR BID

RETURN WITH BID

5. The quantities appearing in the bid schedule are approximate and are prepared for the comparison of bids. Payment to the Contractor will be made only for the actual quantities of work performed and accepted or materials furnished according to the contract. The scheduled quantities of work to be done and materials to be furnished may be increased, decreased or omitted as hereinafter provided.
6. Submission of a bid shall be conclusive assurance and warranty the bidder has examined the plans and understands all requirements for the performance of work. The bidder will be responsible for all errors in the proposal resulting from failure or neglect to conduct an in depth examination. The Awarding Authority will, in no case be responsible for any costs, expenses, losses or changes in anticipated profits resulting from such failure or neglect of the bidder.
7. The bidder shall take no advantage of any error or omission in the proposal and advertised contract.
8. If a special envelope is supplied by the Awarding Authority, each proposal should be submitted in that envelope furnished by the Awarding Agency and the blank spaces on the envelope shall be filled in correctly to clearly indicate its contents. When an envelope other than the special one furnished by the Awarding Authority is used, it shall be marked to clearly indicate its contents. When sent by mail, the sealed proposal shall be addressed to the Awarding Authority at the address and in care of the official in whose office the bids are to be received. All proposals shall be filed prior to the time and at the place specified in the Notice to Bidders. Proposals received after the time specified will be returned to the bidder unopened.
9. Permission will be given to a bidder to withdraw a proposal if the bidder makes the request in writing or in person before the time for opening proposals.

NOT FOR

NOT FOR BID

RETURN WITH BID

PROPOSAL

County DUPAGE
Local Public Agency VILLA PARK
Section Number N/A
Route SECOND AVENUE

1. Proposal of

for the improvement of the above section by the construction of STORM SEWER INSTALLATION, PAVEMENT RECONSTRUCTION, CURB AND GUTTER R&R, SIDEWALK R&R, WATER AND SANITARY SEWER SERVICE ADJUSTMENTS, AND PARKWAY RESTORATION.

a total distance of 1103 feet, of which a distance of 1103 feet, (0.210 miles) are to be improved.

2. The plans for the proposed work are those prepared by CHRISTOPHER B. BURKE ENGINEERING, LTD and approved by the Department of Transportation on N/A

3. The specifications referred to herein are those prepared by the Department of Transportation and designated as "Standard Specifications for Road and Bridge Construction" and the "Supplemental Specifications and Recurring Special Provisions" thereto, adopted and in effect on the date of invitation for bids.

4. The undersigned agrees to accept, as part of the contract, the applicable Special Provisions indicated on the "Check Sheet for Recurring Special Provisions" contained in this proposal.

5. The undersigned agrees to complete the work within 60 calendar days or by --- unless additional time is granted in accordance with the specifications.

6. A proposal guaranty in the proper amount, as specified in BLRS Special Provision for Bidding Requirements and Conditions for Contract Proposals, will be required. Bid Bonds will be allowed as a proposal guaranty. Accompanying this proposal is either a bid bond if allowed, on Department form BLR 12230 or a proposal guaranty check, complying with the specifications, made payable to:

VILLAGE Treasurer of VILLA PARK

The amount of the check is 5% OF BID AMOUNT ()

7. In the event that one proposal guaranty check is intended to cover two or more proposals, the amount must be equal to the sum of the proposal guaranties, which would be required for each individual proposal. If the proposal guaranty check is placed in another proposal, it will be found in the proposal for: Section Number N/A

8. The successful bidder at the time of execution of the contract will be required to deposit a contract bond for the full amount of the award. When a contract bond is not required, the proposal guaranty check will be held in lieu thereof. If this proposal is accepted and the undersigned fails to execute a contract and contract bond as required, it is hereby agreed that the Bid Bond or check shall be forfeited to the Awarding Authority.

9. Each pay item should have a unit price and a total price. If no total price is shown or if there is a discrepancy between the product of the unit price multiplied by the quantity, the unit price shall govern. If a unit price is omitted, the total price will be divided by the quantity in order to establish a unit price.

10. A bid will be declared unacceptable if neither a unit price nor a total price is shown.

11. The undersigned submits herewith the schedule of prices on BLR 12200a covering the work to be performed under this contract.

12. The undersigned further agrees that if awarded the contract for the sections contained in the combinations on BLR 12200a, the work shall be in accordance with the requirements of each individual proposal for the multiple bid specified in the Schedule for Multiple Bids below.

13. The undersigned is aware that Federal Labor Standards, Prevailing Wage Rates, and Section 3 Regulations apply to all work performed on this contract. It is the Contractor's responsibility to comply with these requirements and to assure compliance by his/her Subcontractors and/or any lower tier Subcontractors required by this contract.

NOT FOR BID



SCHEDULE OF PRICES

County DUPAGE
 Local Public Agency VILLA PARK
 Section N/A
 Route SECOND AVENUE

Schedule for Multiple Bids

Combination Letter	Sections Included in Combinations	Total

Schedule for Single Bid

(For complete information covering these items, see plans and specifications)

Bidder's Proposal for making Entire Improvements	
--	--

Item No.	Items	Unit	Quantity	Unit Price	Total
1	TEMPORARY FENCE	FOOT	200		
2	TREE TRUNK PROTECTION	EACH	32		
3	TREE ROOT PRUNING	EACH	16		
4	REMOVAL AND DISPOSAL OF UNSUITABLE MATERIAL	CU YD	325		
5	POROUS GRANULAR EMBANKMENT	CU YD	325		
6	TRENCH BACKFILL	CU YD	1106		
7	GEOTECHNICAL FABRIC FOR GROUND STABILIZATION	SQ YD	3241		
8	SODDING	SQ YD	2690		
9	SUPPLEMENTAL WATERING	UNIT	122		
10	INLET FILTERS	EACH	15		
11	AGGREGATE BASE COURSE, TYPE B 6"	SQ YD	3241		
12	BITUMINOUS MATERIALS (TACK COAT)	POUND	766		
13	HOT-MIX ASPHALT BINDER COURSE, IL-19.0, N50	TON	763		
14	HOT-MIX ASPHALT SURFACE COURSE, MIX "D", N50	TON	382		
15	PORTLAND CEMENT CONCRETE DRIVEWAY PAVEMENT, 6 INCH	SQ YD	158		

NOT FOR BID

RETURN WITH BID

Bidder's Proposal for making Entire Improvements

Item No.	Items	Unit	Quantity	Unit Price	Total
16	PORTLAND CEMENT CONCRETE SIDEWALK 5 INCH	SQ FT	4425		
17	DETECTABLE WARNINGS	SQ FT	206		
18	PAVEMENT REMOVAL	SQ YD	3241		
19	DRIVEWAY PAVEMENT REMOVAL	SQ YD	407		
20	COMBINATION CURB AND GUTTER REMOVAL	FOOT	2316		
21	SIDEWALK REMOVAL	SQ FT	4602		
22	STORM SEWER REMOVAL 8"	FOOT	144		
23	STORM SEWER REMOVAL 12"	FOOT	35		
24	STORM SEWER REMOVAL 30"	FOOT	7		
25	DOMESTIC WATER SERVICE BOXES TO BE ADJUSTED	EACH	15		
26	CATCH BASINS, TYPE A, 4'-DIAMETER, TYPE 11 FRAME AND GRATE	EACH	8		
27	CATCH BASINS, TYPE C, TYPE 11 FRAME AND GRATE	EACH	1		
28	MANHOLES, TYPE A, 4'-DIAMETER, TYPE 1 FRAME, CLOSED LID	EACH	1		
29	MANHOLES, TYPE A, 5'-DIAMETER, TYPE 1 FRAME, CLOSED LID	EACH	2		
30	MANHOLES, TYPE A, 7'-DIAMETER, TYPE 1 FRAME, CLOSED LID	EACH	1		
31	CATCH BASINS TO BE ADJUSTED	EACH	5		
32	MANHOLES TO BE ADJUSTED	EACH	1		
33	VALVE BOXES TO BE ADJUSTED	EACH	1		
34	FRAMES AND GRATES, TYPE 11	EACH	1		
35	COMBINATION CONCRETE CURB AND GUTTER, TYPE B-6.12	FOOT	2316		
36	THERMOPLASTIC PAVEMENT MARKING - LINE 24"	FOOT	77		
37	EXPLORATION TRENCH, SPECIAL	FOOT	60		
38	TEMPORARY ACCESS (PRIVATE ENTRANCE)	EACH	23		
39	TEMPORARY ACCESS (ROAD)	EACH	7		
40	ADJUSTING WATER SERVICE LINES	EACH	9		
41	TRAFFIC CONTROL AND PROTECTION, (SPECIAL)	L SUM	1		

NOT FOR BID

RETURN WITH BID

Bidder's Proposal for making Entire Improvements

Item No.	Items	Unit	Quantity	Unit Price	Total
42	HOT-MIX ASPHALT DRIVEWAY PAVEMENT, 4"	SQ YD	316		
43	CONSTRUCTION LAYOUT	L SUM	1		
44	DRAINAGE STRUCTURE TO BE REMOVED	EACH	1		
45	STORM SEWER (WATER MAIN REQUIREMENTS) 12 INCH	FOOT	28		
46	ADJUSTING SANITARY SEWERS, 8-INCH DIAMETER OR LESS - DUCTILE IRON	FOOT	80		
47	ADJUSTING SANITARY SEWERS, 8-INCH OR LESS	FOOT	160		
48	BRICK DRIVEWAY REMOVAL AND REPLACEMENT	SQ YD	22		
49	CONTINGENCY ALLOWANCE	DOLLARS	25000	\$1.00	\$25,000.00
50	PRE-CONSTRUCTION VIDEO RECORDING	LSUM	1		
51	SANITARY MANHOLE, TYPE A, 4'-DIAMETER, TYPE 1 FRAME, CLOSED LID	EACH	5		
52	SANITARY SERVICE CONNECTION	EACH	4		
53	SANITARY SERVICE REPLACEMENT	FOOT	100		
54	SANITARY SEWER SERVICE COMBINATION CLEANOUT CHECK VALVE	EACH	4		
55	STORM SEWERS, CLASS B (PVC), 6"	FOOT	50		
56	STORM SEWERS, RUBBER GASKET, CLASS A (RCP), 12"	FOOT	162		
57	STORM SEWERS, RUBBER GASKET, CLASS A (RCP), 24"	FOOT	300		
58	STORM SEWERS, RUBBER GASKET, CLASS A (RCP), 36"	FOOT	559		
59	TREE PRUNING	EACH	16		
60	WATER SERVICE CONNECTION (LONG), 1"	EACH	4		
61	WATER SERVICE CONNECTION (SHORT), 1"	EACH	4		
62	WATER USAGE CREDIT	TGAL	100	\$8.85	\$885.00
63	WATER USAGE DEDUCTION	TGAL	100	(\$8.85)	(\$885.00)
END OF SCHEDULE OF PRICES				TOTAL =	
NOTE: THE DUPAGE COUNTY COMMUNITY DEVELOPMENT COMMISSION (CDC) CONDITIONS FEDERAL GRANT BID MANUAL LANGUAGE AND STATEMENTS MUST BE COMPLETED BY THE CONTRACTOR AND RETURNED WITH THE BID PROPOSAL.					

NOT FOR BID

CONTRACTOR CERTIFICATIONS

County	<u>DUPAGE</u>
Local Public Agency	<u>VILLA PARK</u>
Section Number	<u>N/A</u>
Route	<u>SECOND AVENUE</u>

The certifications hereinafter made by the bidder are each a material representation of fact upon which reliance is placed should the Department enter into the contract with the bidder.

1. **Debt Delinquency.** The bidder or contractor or subcontractor, respectively, certifies that it is not delinquent in the payment of any tax administered by the Department of Revenue unless the individual or other entity is contesting, in accordance with the procedures established by the appropriate revenue Act, its liability for the tax or the amount of tax. Making a false statement voids the contract and allows the Department to recover all amounts paid to the individual or entity under the contract in a civil action.

2. **Bid-Rigging or Bid Rotating.** The bidder or contractor or subcontractor, respectively, certifies that it is not barred from contracting with the Department by reason of a violation of either 720 ILCS 5/33E-3 or 720 ILCS 5/33E-4.

A violation of Section 33E-3 would be represented by a conviction of the crime of bid-rigging which, in addition to Class 3 felony sentencing, provides that any person convicted of this offense or any similar offense of any state or the United States which contains the same elements as this offense shall be barred for 5 years from the date of conviction from contracting with any unit of State or local government. No corporation shall be barred from contracting with any unit of State or local government as a result of a conviction under this Section of any employee or agent of such corporation if the employee so convicted is no longer employed by the corporation and: (1) it has been finally adjudicated not guilty or (2) if it demonstrates to the governmental entity with which it seeks to contract and that entity finds that the commission of the offense was neither authorized, requested, commanded, nor performed by a director, officer or a high managerial agent in behalf of the corporation.

A violation of Section 33E-4 would be represented by a conviction of the crime of bid-rotating which, in addition to Class 2 felony sentencing, provides that any person convicted of this offense or any similar offense of any state or the United States which contains the same elements as this offense shall be permanently barred from contracting with any unit of State or local government. No corporation shall be barred from contracting with any unit of State or local government as a result of a conviction under this Section of any employee or agent of such corporation if the employee so convicted is no longer employed by the corporation and: (1) it has been finally adjudicated not guilty or (2) if it demonstrates to the governmental entity with which it seeks to contract and that entity finds that the commission of the offense was neither authorized, requested, commanded, nor performed by a director, officer or a high managerial agent in behalf of the corporation.

3. **Bribery.** The bidder or contractor or subcontractor, respectively, certifies that it has not been convicted of bribery or attempting to bribe an officer or employee of the State of Illinois or any unit of local government, nor has the firm made an admission of guilt of such conduct which is a matter of record, nor has an official, agent, or employee of the firm committed bribery or attempted bribery on behalf of the firm and pursuant to the direction or authorization of a responsible official of the firm.

4. **Interim Suspension or Suspension.** The bidder or contractor or subcontractor, respectively, certifies that it is not currently under a suspension as defined in Subpart I of Title 44 Subtitle A Chapter III Part 6 of the Illinois Administrative Code. Furthermore, if suspended prior to completion of this work, the contract or contracts executed for the completion of this work may be cancelled.

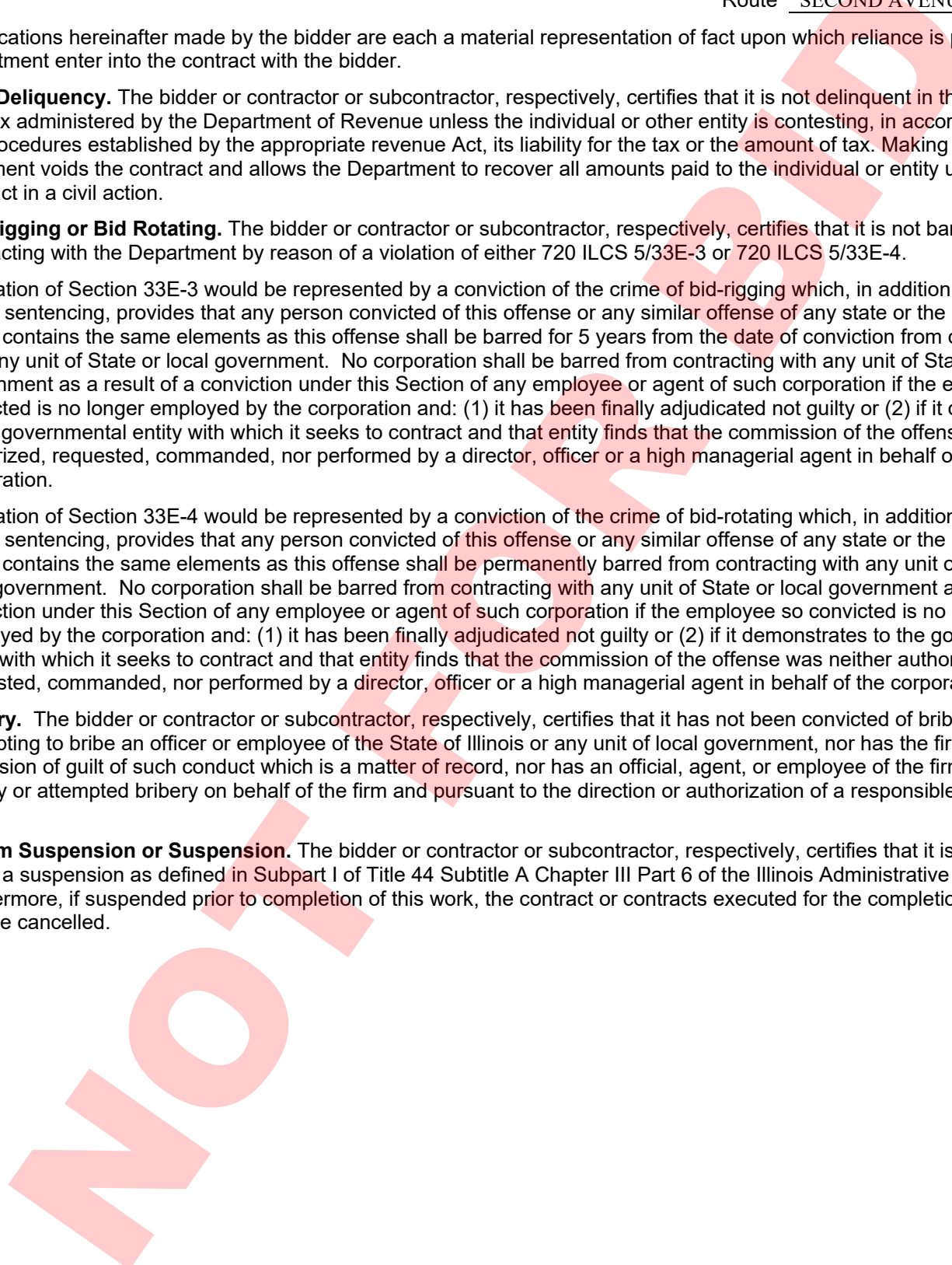

NOT FOR BID

RETURN WITH BID

SIGNATURES

County DUPAGE
Local Public Agency VILLA PARK
Section Number N/A
Route SECOND AVENUE

(If an individual)

Signature of Bidder _____

Business Address _____

(If a partnership)

Firm Name _____

Signed By _____

Business Address _____

Inset Names and Addressed of All Partners



(If a corporation)

Corporate Name _____

Signed By _____

President

Business Address _____

Inset Names of Officers



President _____

Secretary _____

Treasurer _____

Attest: _____
Secretary

NOT FOR BID

Route SECOND AVENUE
 County DUPAGE
 Local Agency VILLA PARK
 Section N/A

RETURN WITH BID

PAPER BID BOND

WE _____ as PRINCIPAL,
 and _____ as SURETY,

are held jointly, severally and firmly bound unto the above Local Agency (hereafter referred to as "LA") in the penal sum of 5% of the total bid price, or for the amount specified in the proposal documents in effect on the date of invitation for bids whichever is the lesser sum. We bind ourselves, our heirs, executors, administrators, successors, and assigns, jointly pay to the LA this sum under the conditions of this instrument.

WHEREAS THE CONDITION OF THE FOREGOING OBLIGATION IS SUCH that, the said PRINCIPAL is submitting a written proposal to the LA acting through its awarding authority for the construction of the work designated as the above section.

THEREFORE if the proposal is accepted and a contract awarded to the PRINCIPAL by the LA for the above designated section and the PRINCIPAL shall within fifteen (15) days after award enter into a formal contract, furnish surety guaranteeing the faithful performance of the work, and furnish evidence of the required insurance coverage, all as provided in the "Standard Specifications for Road and Bridge Construction" and applicable Supplemental Specifications, then this obligation shall become void; otherwise it shall remain in full force and effect.

IN THE EVENT the LA determines the PRINCIPAL has failed to enter into a formal contract in compliance with any requirements set forth in the preceding paragraph, then the LA acting through its awarding authority shall immediately be entitled to recover the full penal sum set out above, together with all court costs, all attorney fees, and any other expense of recovery.

IN TESTIMONY WHEREOF, the said PRINCIPAL and the said SURETY have caused this instrument to be signed by their respective officers this _____ day of _____

Principal

 (Company Name) _____ (Company Name)
 By: _____ By: _____
 (Signature and Title) (Signature and Title)

(If PRINCIPLE is a joint venture of two or more contractors, the company names, and authorized signatures of each contractor must be affixed.)

Surety

By: _____
 (Name of Surety) _____ (Signature of Attorney-in-Fact)

STATE OF ILLINOIS,
 COUNTY OF _____

I, _____, a Notary Public in and for said county,
 do hereby certify that _____

(Insert names of individuals signing on behalf of PRINCIPAL & SURETY)

who are each personally known to me to be the same persons whose names are subscribed to the foregoing instrument on behalf of PRINCIPAL and SURETY, appeared before me this day in person and acknowledged respectively, that they signed and delivered said instruments as their free and voluntary act for the uses and purposes therein set forth.

Given under my hand and notarial seal this _____ day of _____

My commission expires _____
 _____ (Notary Public)

ELECTRONIC BID BOND

Electronic bid bond is allowed (box must be checked by LA if electronic bid bond is allowed)

The Principal may submit an electronic bid bond, in lieu of completing the above section of the Proposal Bid Bond Form. By providing an electronic bid bond ID code and signing below, the Principal is ensuring the identified electronic bid bond has been executed and the Principal and Surety are firmly bound unto the LA under the conditions of the bid bond as shown above. (If PRINCIPAL is a joint venture of two or more contractors, an electronic bid bond ID code, company/Bidder name title and date must be affixed for each contractor in the venture.)

--	--	--	--	--	--	--	--	--	--	--	--	--	--	--	--	--	--	--	--

Electronic Bid Bond ID Code

 (Company/Bidder Name)

 (Signature and Title) _____

 Date

NOT FOR BID

**DUPAGE COUNTY COMMUNITY
DEVELOPMENT COMMISSION (CDC) CONDITIONS
FEDERAL GRANT BID MANUAL LANGUAGE AND STATEMENTS**

Please read these conditions carefully and sign the acknowledgement on next page. Note that conditions listed below supersede any other conditions listed elsewhere in the manual. All these conditions apply to any labor providing contractors and any lower level subcontractors.

I. Labor Standards Notice *(also to be listed on the Front Cover)*

**FEDERAL LABOR STANDARDS AND DAVIS-BACON PREVAILING WAGE RATES
WILL APPLY TO THIS PROJECT.**

**Please refer to the Federal Requirements included in the Bid Manual for additional information on federal labor standards and Davis-Bacon prevailing wage requirements.*

II. Bid Security Statement

All bid proposals must be accompanied by a Bid bond, certified check, or bank cashier's check payable to the owner for five percent (5%) of the amount of the bid.

III. Performance and Payment Bond Statement

The successful bidder for the project will be required to enter into Performance and Payment bonds equal to 100% of the bid with approved sureties, which shall be conditioned upon the proper and faithful performance by the contractor of the work specified in accordance with the contract documents.

IV. Brand Name Only Statement

Neither owner nor contractor shall limit materials to only brand-name products. Non-brand name materials of equal specification do qualify and are acceptable.

V. Cost Plus Statement

Cost-plus a percentage of cost and percentage of construction cost methods are prohibited from use on this project in any form or condition.

VI. Change Order Statement

Should change orders be necessary, CDC staff must receive copies and explanation of necessity for review. Should change orders be necessary and they exceed the bonded amount, bonds must be increased to match the new contract total.

VII. Federal Wage Determination Statement

This project is paid for in part with Federal grant funds through the Community Development Block Grant Program. Davis-Bacon Wage Decisions apply and are included in this packet. Davis-Bacon wages are superseded only in instances, by and where Illinois Prevailing Wage

NOT FOR BID

exceeds Davis-Bacon in wage, fringe benefits, and/or trade stipulations (monetary and/or non-monetary requirements). Should this project not start within 90 days of award, the wage determinations shall be replaced with the most current decision.

VIII. Non-Discrimination Statement

Employers shall not discriminate, directly or indirectly, against employees or applicants for employment on the basis of race, color, religion, sex, national origin, age, familial status, or disability.

IX. WBE/MBE Encouragement Statement *(also to be listed on the Front Cover)*

Minority and Women Owned Business Enterprises (MBE/WBE) are encouraged to submit bids on this Project.

X. Debarment Statement

The successful bidder for the project must clear a contractor debarment search on the System for Award Management (SAM) in order to be eligible to receive Federal grant funds.

XI. Signature Statement

The undersigned is aware that Federal Labor Standards and Davis-Bacon Prevailing Wage Rates apply to all work performed under this contract. It is the contractor's responsibility to comply with these requirements and to assure compliance by his/her subcontractors and any lower tier subcontractors providing labor for said project.

DuPage County Community Development Commission wishes an acknowledgement from the bidder that they have read and understand the conditions listed above.

Please sign below, print your company name, date this document, and submit it with the complete bid package.

Signature: _____

Company Name: _____

Date: _____

NOT FOR BID

CONFLICT OF INTEREST DISCLOSURE – CDBG-DR

Please initial each true and applicable statement:

	1. The undersigned understands that this project is being funded with Federal dollars under the Community Development Block Grant – Disaster Recovery (CDBG-DR) Program.
Please select one of the following designations:	
	2. The undersigned has made application to be the owner or developer of a project funded with CDBG-DR.
	3. The undersigned desires to participate as a contractor or subcontractor under a construction project funded with CDBG-DR.
	4. The undersigned has made application to be a subrecipient of DuPage County funding under CDBG-DR.
	5. I am a participant in a CDBG-DR funded buy-out or acquisition of property.
Please select one of the following statements:	
	6. The undersigned hereby certifies that he/she or (if other than an individual) any owners, employees, agents, consultants, officers, or elected or appointed officials (including members of its board of directors) <u>do(es) not have</u> any business or family tie to any current or former employee, agent, consultant, officer, or elected or appointed official of DuPage County. Such a tie includes the following relationships and in-laws of such relationships (whether by blood, marriage or adoption): spouse, parent (including a stepparent), child (including a stepchild), brother, sister (including a stepbrother or stepsister), grandparent, grandchild and no such tie has existed during the past twelve months. All these categories of persons and relations are considered to be “covered persons” under Federal conflict of interest regulations.
	7. The undersigned <u>does have</u> a business or family tie to a current or former (within the last twelve months) employee, agent, consultant, officer, or elected or appointed official of DuPage County. Please note that DuPage County will need to review such business or family tie to determine if it constitutes a conflict of interest under applicable Federal regulations prior to entering into any agreement with you. Please list each such business or family tie:
Please select one of the following statements:	
	8. The undersigned is an individual or sole proprietor and am signing this on behalf of myself.
	9. The undersigned is a partnership and the signature below represents the statement of the partnership and all general and limited partners, individually, and collectively all covered persons associated with the partnership.
	10. The undersigned is a corporation and the signature below is that of a duly authorized corporate officer and represents the statement of each and all covered persons associated with the corporation.

NOT FOR BID

Printed Name:	
Title (if applicable):	
Name of organization (if applicable)	
Signature:	
Date:	

Printed Name:	
Title (if applicable):	
Name of organization (if applicable)	
Signature:	
Date:	

NOT FOR BID

NOT FOR BID



Apprenticeship or Training Program Certification

Return with Bid

Route SECOND AVENUE
County DUPAGE
Local Agency VILLA PARK
Section N/A

All contractors are required to complete the following certification:

- For this contract proposal or for all groups in this deliver and install proposal.
For the following deliver and install groups in this material proposal:

Blank lines for listing deliver and install groups.

Illinois Department of Transportation policy, adopted in accordance with the provisions of the Illinois Highway Code, requires this contract to be awarded to the lowest responsive and responsible bidder. The award decision is subject to approval by the Department. In addition to all other responsibility factors, this contract or deliver and install proposal requires all bidders and all bidders' subcontractors to disclose participation in apprenticeship or training programs that are (1) approved by and registered with the United States Department of Labor's Bureau of Apprenticeship and Training, and (2) applicable to the work of the above indicated proposals or groups. Therefore, all bidders are required to complete the following certification:

- I. Except as provided in paragraph IV below, the undersigned bidder certifies that it is a participant, either as an individual or as part of a group program, in an approved apprenticeship or training program applicable to each type of work or craft that the bidder will perform with its own employees.
II. The undersigned bidder further certifies for work to be performed by subcontract that each of its subcontractors submitted for approval either (A) is, at the time of such bid, participating in an approved, applicable apprenticeship or training program; or (B) will, prior to commencement of performance of work pursuant to this contract, establish participation in an approved apprenticeship or training program applicable to the work of the subcontract.
III. The undersigned bidder, by inclusion in the list in the space below, certifies the official name of each program sponsor holding the Certificate of Registration for all of the types of work or crafts in which the bidder is a participant and that will be performed with the bidder's employees. Types of work or craft that will be subcontracted shall be included and listed as subcontract work. The list shall also indicate any type of work or craft job category for which there is no applicable apprenticeship or training program available.

Blank lines for listing program sponsors and subcontracted work.

NOT FOR BID

IV. Except for any work identified above, any bidder or subcontractor that shall perform all or part of the work of the contract or deliver and install proposal solely by individual owners, partners or members and not by employees to whom the payment of prevailing rates of wages would be required, check the following box, and identify the owner/operator workforce and positions of ownership.

The requirements of this certification and disclosure are a material part of the contract, and the contractor shall require this certification provision to be included in all approved subcontracts. The bidder is responsible for making a complete report and shall make certain that each type of work or craft job category that will be utilized on the project is accounted for and listed. The Department at any time before or after award may require the production of a copy of each applicable Certificate of Registration issued by the United States Department of Labor evidencing such participation by the contractor and any or all of its subcontractors. In order to fulfill the participation requirement, it shall not be necessary that any applicable program sponsor be currently taking or that it will take applications for apprenticeship, training or employment during the performance of the work of this contract or deliver and install proposal.

Bidder: _____ By: _____ (Signature)
Address: _____ Title: _____

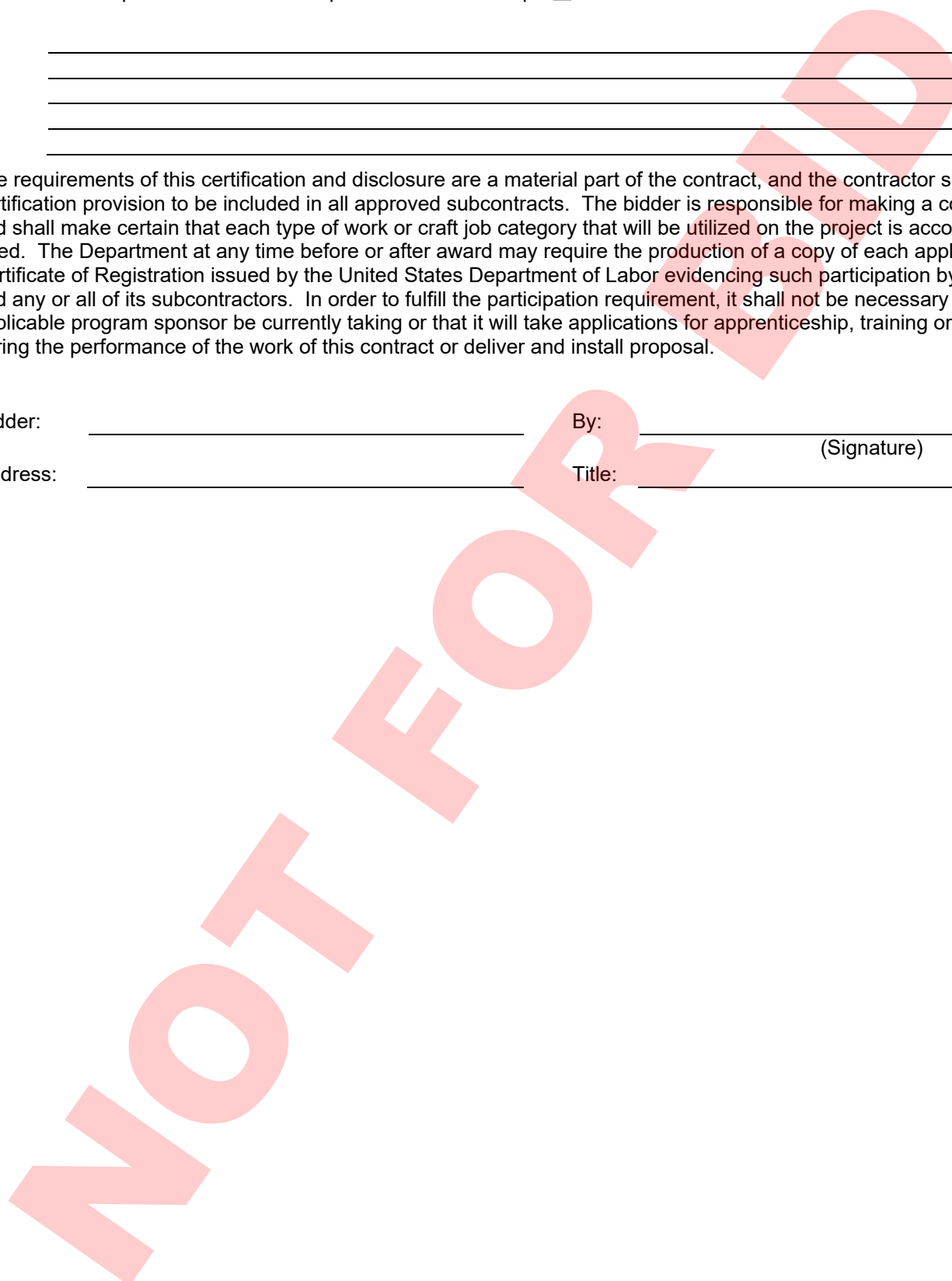

NOT FOR BID



Illinois Department of Transportation

Affidavit of Illinois Business Office

County DUPAGE
Local Public Agency VILLA PARK
Section Number N/A
Route SECOND AVENUE

State of _____)
County of _____) ss.

I, _____ of _____, _____,
(Name of Affiant) (City of Affiant) (State of Affiant)

being first duly sworn upon oath, states as follows:

1. That I am the _____ of _____ bidder.
officer or position
2. That I have personal knowledge of the facts herein stated.
3. That, if selected under this proposal, _____, will maintain a
(bidder)
business office in the State of Illinois which will be located in _____ County, Illinois.
4. That this business office will serve as the primary place of employment for any persons employed in the construction contemplated by this proposal.
5. That this Affidavit is given as a requirement of state law as provided in Section 30-22(8) of the Illinois Procurement Code.

(Signature)

(Print Name of Affiant)

This instrument was acknowledged before me on _____ day of _____, _____.

(SEAL)

(Signature of Notary Public)

NOT FOR BID



Illinois Department of Transportation

Bureau of Construction
2300 South Dirksen Parkway/Room 322
Springfield, Illinois 62764

Affidavit of Availability For the Letting of 07/10/2018

Instructions: Complete this form by either typing or using black ink. "Authorization to Bid" will not be issued unless both sides of this form are completed in detail. Use additional forms as needed to list all work.

Part I. Work Under Contract

List below all work you have under contract as either a prime contractor or a subcontractor. It is required to include all pending low bids not yet awarded or rejected. In a joint venture, list only that portion of the work which is the responsibility of your company. The uncompleted dollar value is to be based upon the most recent engineer's or owners estimate, and must include work subcontracted to others. If no work is contracted, show **NONE**.

	1	2	3	4	Awards Pending	
Contract Number						
Contract With						
Estimated Completion Date						
Total Contract Price						Accumulated Totals
Uncompleted Dollar Value if Firm is the Prime Contractor						
Uncompleted Dollar Value if Firm is the Subcontractor						
Total Value of All Work						

Part II. Awards Pending and Uncompleted Work to be done with your own forces.

List below the uncompleted dollar value of work for each contract and awards pending to be completed with your own forces. All work subcontracted to others will be listed on the reverse of this form. In a joint venture, list only that portion of the work to be done by your company. If no work is contracted, show **NONE**.

						Accumulated Totals
Earthwork						
Portland Cement Concrete Paving						
HMA Plant Mix						
HMA Paving						
Clean & Seal Cracks/Joints						
Aggregate Bases & Surfaces						
Highway, R.R. and Waterway Structures						
Drainage						
Electrical						
Cover and Seal Coats						
Concrete Construction						
Landscaping						
Fencing						
Guardrail						
Painting						
Signing						
Cold Milling, Planning & Rotomilling						
Demolition						
Pavement Markings (Paint)						
Other Construction (List)						
						\$ 0.00
Totals						

Disclosure of this information is **REQUIRED** to accomplish the statutory purpose as outlined in the "Illinois Procurement Code." Failure to comply will result in non-issuance of an "Authorization To Bid." This form has been approved by the State Forms Management Center.

NOT FOR BID

Part III. Work Subcontracted to Others.

For each contract described in Part I, list all the work you have subcontracted to others.

	1	2	3	4	Awards Pending
Subcontractor					
Type of Work					
Subcontract Price					
Amount Uncompleted					
Subcontractor					
Type of Work					
Subcontract Price					
Amount Uncompleted					
Subcontractor					
Type of Work					
Subcontract Price					
Amount Uncompleted					
Subcontractor					
Type of Work					
Subcontract Price					
Amount Uncompleted					
Subcontractor					
Type of Work					
Subcontract Price					
Amount Uncompleted					
Total Uncompleted					

I, being duly sworn, do hereby declare that this affidavit is a true and correct statement relating to ALL uncompleted contracts of the undersigned for Federal, State, County, City and private work, including ALL subcontract work, ALL pending low bids not yet awarded or rejected and ALL estimated completion dates.

Subscribed and sworn to before me
 this _____ day of _____, _____ Type or Print Name _____
 Officer or Director Title

Signed _____

 Notary Public

My commission expires _____

(Notary Seal)

Company _____

Address _____

NOT FOR BID



PROPOSAL SUBMITTED BY		
Contractor's Name		
Street	P.O. Box	
City	State	Zip Code

STATE OF ILLINOIS

COUNTY DUPAGE
VILLA PARK
 (Name of City, Village, Town or Road District)

FOR THE IMPROVEMENT OF
 STREET NAME OR ROUTE SECOND AVENUE
 SECTION NO. N/A
 TYPES OF FUNDS CDBG-DR/LOCAL

- SPECIFICATIONS (required) PLANS (required) CONTRACT BOND (when required)

NOT FOR BIDDING

NOT FOR BID

County DUPAGE
Local Public Agency VILLA PARK
Section Number N/A
Route SECOND AVENUE

1. THIS AGREEMENT, made and concluded the _____ day of _____, _____
Month and Year
between the Village of Villa Park
acting by and through its Board of Trustees known as the party of the first part, and
_____ his/their executors, administrators, successors or assigns,
known as the party of the second part.

2. Witnesseth: That for and in consideration of the payments and agreements mentioned in the Proposal hereto attached, to be made and performed by the party of the first part, and according to the terms expressed in the Bond referring to these presents, the party of the second part agrees with said party of the first part at his/their own proper cost and expense to do all the work, furnish all materials and all labor necessary to complete the work in accordance with the plans and specifications hereinafter described, and in full compliance with all of the terms of this agreement and the requirements of the Engineer under it.

3. And it is also understood and agreed that the LPA Formal Contract Proposal, Special Provisions, Affidavit of Illinois Business Office, Apprenticeship or Training Program Certification, and Contract Bond hereto attached, and the Plans for Section Second Avenue, in the Village of Villa Park, approved by the Illinois Department of Transportation on _____, are essential documents of this contract and are a part hereof.
Date

4. IN WITNESS WHEREOF, The said parties have executed these presents on the date above mentioned.

Attest: _____ The Village of Villa Park
Clerk By _____
Party of the First Part

(Seal) _____
(If a Corporation)
Corporate Name _____
By _____
President Party of the Second Part
(If a Co-Partnership)

Attest: _____
Secretary

Partners doing Business under the firm name of

Party of the Second Part
(If an individual)

Party of the Second Part

NOT FOR BID



Route SECOND AVENUE
 County DUPAGE
 Local Agency VILLA PARK
 Section N/A

We , _____

a/an) Individual Co-partnership Corporation organized under the laws of the State of _____ ,
as PRINCIPAL, and _____

_____ as SURETY,

are held and firmly bound unto the above Local Agency (hereafter referred to as "LA") in the penal sum of _____

_____ Dollars (_____), lawful money of the United States, well and truly to be paid unto said LA, for the payment of which we bind ourselves, our heirs, executors, administrators, successors, jointly to pay to the LA this sum under the conditions of this instrument.

WHEREAS THE CONDITION OF THE FOREGOING OBLIGATION IS SUCH that, the said Principal has entered into a written contract with the LA acting through its awarding authority for the construction of work on the above section, which contract is hereby referred to and made a part hereof, as if written herein at length, and whereby the said Principal has promised and agreed to perform said work in accordance with the terms of said contract, and has promised to pay all sums of money due for any labor, materials, apparatus, fixtures or machinery furnished to such Principal for the purpose of performing such work and has further agreed to pay all direct and indirect damages to any person, firm, company or corporation suffered or sustained on account of the performance of such work during the time thereof and until such work is completed and accepted; and has further agreed that this bond shall inure to the benefit of any person, firm, company or corporation to whom any money may be due from the Principal, subcontractor or otherwise for any such labor, materials, apparatus, fixtures or machinery so furnished and that suit may be maintained on such bond by any such person, firm, company or corporation for the recovery of any such money.

NOW THEREFORE, if the said Principal shall well and truly perform said work in accordance with the terms of said contract, and shall pay all sums of money due or to become due for any labor, materials, apparatus, fixtures or machinery furnished to him for the purpose of constructing such work, and shall commence and complete the work within the time prescribed in said contract, and shall pay and discharge all damages, direct and indirect, that may be suffered or sustained on account of such work during the time of the performance thereof and until the said work shall have been accepted, and shall hold the LA and its awarding authority harmless on account of any such damages and shall in all respects fully and faithfully comply with all the provisions, conditions and requirements of said contract, then this obligation to be void; otherwise to remain in full force and effect.

NOT FOR BID

IN TESTIMONY WHEREOF, the said PRINCIPAL and the said SURETY have caused this instrument to be signed by their respective officers this _____ day of _____ A.D. _____

PRINCIPAL

(Company Name)

(Company Name)

By: _____
(Signature & Title)

By: _____
(Signature & Title)

Attest: _____
(Signature & Title)

Attest: _____
(Signature & Title)

(If PRINCIPAL is a joint venture of two or more contractors, the company names and authorized signature of each contractor must be affixed.)

STATE OF ILLINOIS,
COUNTY OF _____

I, _____, a Notary Public in and for said county, do hereby certify that

(Insert names of individuals signing on behalf or PRINCIPAL)

who are each personally known to me to be the same persons whose names are subscribed to the foregoing instrument on behalf of PRINCIPAL, appeared before me this day in person and acknowledged respectively, that they signed and delivered said instrument as their free and voluntary act for the uses and purposes therein set forth.

Given under my hand and notarial seal this _____ day of _____ A.D. _____

My commission expires _____

Notary Public (SEAL)

SURETY

(Name of Surety)

By: _____
(Signature of Attorney-in-Fact)

STATE OF ILLINOIS. (SEAL)
COUNTY OF _____

I, _____, a Notary Public in and for said county, do hereby certify that

(Insert names of individuals signing on behalf or SURETY)

who are each personally known to me to be the same persons whose names are subscribed to the foregoing instrument on behalf of SURETY, appeared before me this day in person and acknowledged respectively, that they signed and delivered said instrument as their free and voluntary act for the uses and purposes therein set forth.

Given under my hand and notarial seal this _____ day of _____ A.D. _____

My commission expires _____

Notary Public (SEAL)

Approved this _____ day of _____, A.D. 2018

Attest: _____

Village Clerk

Village of Villa Park

(Awarding Authority)

(Chairman/Mayor/President)

NOT FOR BID

INDEX
FOR
SUPPLEMENTAL SPECIFICATIONS
AND RECURRING SPECIAL PROVISIONS

Adopted January 1, 2018

This index contains a listing of SUPPLEMENTAL SPECIFICATIONS, frequently used RECURRING SPECIAL PROVISIONS, and LOCAL ROADS AND STREETS RECURRING SPECIAL PROVISIONS.

ERRATA Standard Specifications for Road and Bridge Construction
(Adopted 4-1-16) (Revised 1-1-18)

SUPPLEMENTAL SPECIFICATIONS

<u>Std. Spec. Sec.</u>	<u>Page No.</u>
106 Control of Materials	1
403 Bituminous Surface Treatment (Class A-1, A-2, A-3)	2
404 Micro-Surfacing and Slurry Sealing	3
405 Cape Seal	14
420 Portland Cement Concrete Pavement	24
442 Pavement Patching	26
502 Excavation for Structures	27
503 Concrete Structures	29
504 Precast Concrete Structures	32
542 Pipe Culverts	33
586 Sand Backfill for Vaulted Abutments	34
630 Steel Plate Beam Guardrail	36
631 Traffic Barrier Terminals	39
670 Engineer's Field Office and Laboratory	40
701 Work Zone Traffic Control and Protection	41
704 Temporary Concrete Barrier	42
781 Raised Reflective Pavement Markers	44
888 Pedestrian Push-Button	45
1003 Fine Aggregates	46
1004 Coarse Aggregates	47
1006 Metals	50
1020 Portland Cement Concrete	51
1050 Poured Joint Sealers	53
1069 Pole and Tower	55
1077 Post and Foundation	56
1096 Pavement Markers	57
1101 General Equipment	58
1102 Hot-Mix Asphalt Equipment	59
1103 Portland Cement Concrete Equipment	61
1106 Work Zone Traffic Control Devices	63

NOT FOR BID



The Following Recurring Special Provisions Indicated By An "X" Are Applicable To This Contract And Are Included By Reference:

Recurring Special Provisions

<u>Check Sheet #</u>		<u>Page No.</u>
1	<input type="checkbox"/> Additional State Requirements for Federal-Aid Construction Contracts	64
2	<input type="checkbox"/> Subletting of Contracts (Federal-Aid Contracts)	67
3	<input type="checkbox"/> EEO	68
4	<input type="checkbox"/> Specific EEO Responsibilities Non Federal-Aid Contracts	78
5	<input type="checkbox"/> Required Provisions - State Contracts	83
6	<input type="checkbox"/> Asbestos Bearing Pad Removal	89
7	<input type="checkbox"/> Asbestos Waterproofing Membrane and Asbestos Hot-Mix Asphalt Surface Removal	90
8	<input type="checkbox"/> Temporary Stream Crossings and In-Stream Work Pads	91
9	<input type="checkbox"/> Construction Layout Stakes Except for Bridges	92
10	<input checked="" type="checkbox"/> Construction Layout Stakes	95
11	<input type="checkbox"/> Use of Geotextile Fabric for Railroad Crossing	98
12	<input type="checkbox"/> Subsealing of Concrete Pavements	100
13	<input type="checkbox"/> Hot-Mix Asphalt Surface Correction	104
14	<input type="checkbox"/> Pavement and Shoulder Resurfacing	106
15	<input type="checkbox"/> Patching with Hot-Mix Asphalt Overlay Removal	107
16	<input type="checkbox"/> Polymer Concrete	109
17	<input type="checkbox"/> PVC Pipeliner	111
18	<input type="checkbox"/> Bicycle Racks	112
19	<input type="checkbox"/> Temporary Portable Bridge Traffic Signals	114
20	<input type="checkbox"/> Work Zone Public Information Signs	116
21	<input type="checkbox"/> Nighttime Inspection of Roadway Lighting	117
22	<input type="checkbox"/> English Substitution of Metric Bolts	118
23	<input type="checkbox"/> Calcium Chloride Accelerator for Portland Cement Concrete	119
24	<input type="checkbox"/> Quality Control of Concrete Mixtures at the Plant	120
25	<input checked="" type="checkbox"/> Quality Control/Quality Assurance of Concrete Mixtures	128
26	<input type="checkbox"/> Digital Terrain Modeling for Earthwork Calculations	144
27	<input type="checkbox"/> Reserved	146
28	<input type="checkbox"/> Preventive Maintenance - Bituminous Surface Treatment	147
29	<input type="checkbox"/> Reserved	153
30	<input type="checkbox"/> Reserved	154
31	<input type="checkbox"/> Reserved	155
32	<input type="checkbox"/> Temporary Raised Pavement Markers	156
33	<input type="checkbox"/> Restoring Bridge Approach Pavements Using High-Density Foam	157
34	<input type="checkbox"/> Portland Cement Concrete Inlay or Overlay	160
35	<input type="checkbox"/> Portland Cement Concrete Partial Depth Hot-Mix Asphalt Patching	164

The Following Local Roads And Streets Recurring Special Provisions Indicated By An "X" Are Applicable To This Contract And Are Included By Reference:

Local Roads And Streets Recurring Special Provisions

<u>Check Sheet #</u>		<u>Page No.</u>
LRS 1	Reserved	168
LRS 2	<input type="checkbox"/> Furnished Excavation	169
LRS 3	<input checked="" type="checkbox"/> Work Zone Traffic Control Surveillance	170
LRS 4	<input checked="" type="checkbox"/> Flaggers in Work Zones	171
LRS 5	<input checked="" type="checkbox"/> Contract Claims	172
LRS 6	<input type="checkbox"/> Bidding Requirements and Conditions for Contract Proposals	173
LRS 7	<input type="checkbox"/> Bidding Requirements and Conditions for Material Proposals	179
LRS 8	Reserved	185
LRS 9	<input type="checkbox"/> Bituminous Surface Treatments	186
LRS 10	Reserved	187
LRS 11	<input type="checkbox"/> Employment Practices	188
LRS 12	<input checked="" type="checkbox"/> Wages of Employees on Public Works	190
LRS 13	<input type="checkbox"/> Selection of Labor	192
LRS 14	<input type="checkbox"/> Paving Brick and Concrete Paver Pavements and Sidewalks	193
LRS 15	<input checked="" type="checkbox"/> Partial Payments	196
LRS 16	<input checked="" type="checkbox"/> Protests on Local Lettings	197
LRS 17	<input checked="" type="checkbox"/> Substance Abuse Prevention Program	198
LRS 18	<input type="checkbox"/> Multigrade Cold Mix Asphalt	199

NOT FOR BID

**SECOND AVENUE SEWER SEPARATION
VILLAGE OF VILLA PARK**

INDEX OF SPECIAL PROVISIONS

TITLE	PAGE NO.
DEFINITIONS.....	1
LOCATION OF PROJECT.....	1
DESCRIPTION OF PROJECT.....	1
GENERAL SPECIAL PROVISIONS.....	2
QUALIFICATIONS OF BIDDERS.....	2
BID PRICE LIMITATIONS.....	5
BIDS TO REMAIN SUBJECT TO ACCEPTANCE.....	5
SUBCONTRACTORS.....	5
INSURANCE.....	5
INCREASED OR DECREASED QUANTITIES.....	6
MOBILIZATION.....	6
PORTABLE TOILET.....	6
WORKING HOURS.....	7
HOLIDAYS.....	7
PUBLIC CONVENIENCE AND SAFETY (D-1).....	7
OPERATION OF WATER DISTRIBUTION FACILITIES.....	8
CONSTRUCTION SAFETY AND HEALTH STANDARDS.....	8
FINAL INSPECTION.....	8
MAINTENANCE WARRANTY.....	9
MAINTENANCE OF ROADWAYS.....	9
KEEPING ROADS OPEN TO TRAFFIC.....	10
RESPONSIBILITY FOR VANDALISM.....	10
USE OF FIRE HYDRANTS.....	10
TRENCH BACKFILL AND PIPE BEDDING.....	11
EXCAVATION AND BACKFILLING OF DRAINAGE AND UTILITY STRUCTURES.....	12
SALVAGE AND DISPOSAL OF EXISTING MATERIALS.....	12

**SECOND AVENUE SEWER SEPARATION
VILLAGE OF VILLA PARK**

FRAMES, GRATES AND LIDS	12
DATE OF MANUFACTURE	13
IRON AND STEEL MATERIALS	13
PROTECTION OF EXISTING DRAINAGE FACILITIES DURING CONSTRUCTION	14
PLUGGING EXISTING MANHOLES AND PIPES	14
PROJECT SIGN	15
IEPA CLEAN CONSTRUCTION AND DEMOLITION DEBRIS (CCDD)	16
PAVEMENT CORE, SOIL BORING, AND WASTE DISPOSAL REPORTS	16
PRICE QUOTATIONS AND CHANGE ORDERS	16
BRAND NAME POLICY	17
MATERIAL AND EQUIPMENT STORAGE	17
WORK ADJACENT TO FRANKLIN PARK	17
CONSTRUCTION NOTICES	17
PAY ITEM SPECIAL PROVISIONS	19
PAY ITEM #2 – TREE TRUNK PROTECTION	19
PAY ITEM #3 – TREE ROOT PRUNING	19
PAY ITEM #6 – TRENCH BACKFILL	19
PAY ITEM #8 – SODDING	20
PAY ITEM #10 – INLET FILTERS	20
PAY ITEM #15 – PORTLAND CEMENT CONCRETE DRIVEWAY PAVEMENT, 6 INCH	21
PAY ITEM #16 – PORTLAND CEMENT CONCRETE SIDEWALK 5 INCH	21
PAY ITEM #17 – DETECTABLE WARNINGS	22
PAY ITEM #18 – PAVEMENT REMOVAL	23
PAY ITEM #19 – DRIVEWAY PAVEMENT REMOVAL	23
PAY ITEM #20 – COMBINATION CURB AND GUTTER REMOVAL	23
PAY ITEM #21 – SIDEWALK REMOVAL	24
PAY ITEM #25 – DOMESTIC WATER SERVICE BOXES TO BE ADJUSTED	24
PAY ITEM #26/27 – CATCH BASIN, TYPE SPECIFIED	25

**SECOND AVENUE SEWER SEPARATION
VILLAGE OF VILLA PARK**

PAY ITEM #28/29/30 – MANHOLE, TYPE A.....	25
PAY ITEM #35 – COMBINATION CONCRETE CURB AND GUTTER, TYPE B-6.12.....	25
PAY ITEM #37 – EXPLORATION TRENCH, SPECIAL.....	27
PAY ITEM #38/39 – TEMPORARY ACCESS.....	28
PAY ITEM #40 – ADJUSTING WATER SERVICE LINES.....	28
PAY ITEM #41 – TRAFFIC CONTROL AND PROTECTION (SPECIAL).....	30
PAY ITEM #42 – HOT-MIX ASPHALT DRIVEWAY PAVEMENT, 4”.....	30
PAY ITEM #44 – DRAINAGE STRUCTURES TO BE REMOVED.....	31
PAY ITEM #45 – STORM SEWERS (WATER MAIN REQUIREMENTS).....	31
PAY ITEM #46/47 – ADJUSTING SANITARY SEWERS, 8-INCH DIAMETER OR LESS.....	32
PAY ITEM #48 – BRICK DRIVEWAY REMOVAL AND REPLACEMENT.....	33
PAY ITEM #49 – CONTINGENCY ALLOWANCE.....	34
PAY ITEM #50 – PRE-CONSTRUCTION VIDEO RECORDING.....	35
PAY ITEM #51 – SANITARY MANHOLE, TYPE A, 4’-DIAMETER, TYPE 1 FRAME, CLOSED LID.....	37
PAY ITEM #52 – SANITARY SERVICE CONNECTION.....	38
PAY ITEM #53 – SANITARY SERVICE REPLACEMENT.....	38
PAY ITEM #54 – SANITARY SEWER SERVICE COMBINATION CLEANOUT CHECK VALVE.....	39
PAY ITEM #55 – STORM SEWERS, CLASS B (PVC), 6”.....	40
PAY ITEM #56/57/58 – STORM SEWERS, RUBBER GASKET CLASS A (RCP).....	41
PAY ITEM #59 – TREE PRUNING.....	42
PAY ITEM #60/61 – WATER SERVICE CONNECTION.....	42
PAY ITEM #62 – WATER USAGE CREDIT.....	44
PAY ITEM #63 – WATER USAGE DEDUCTION.....	45
ADJUSTMENTS AND RECONSTRUCTIONS.....	46
FRICITION AGGREGATE (D-1).....	47
GROUND TIRE RUBBER (GTR) MODIFIED ASPHALT BINDER (D-1).....	50
HMA MIXTURE REQUIREMENTS (D-1).....	51

**SECOND AVENUE SEWER SEPARATION
VILLAGE OF VILLA PARK**

RECLAIMED ASPHALT PAVEMENT AND RECLAIMED ASPHALT SHINGLES

(D-1)..... 59

BDE SPECIAL PROVISIONS

LR 102-2

LR 105

LR 107-4

LR 107-7

LR 109

HIGHWAY STANDARDS

APPENDIX A – COMMUNITY DEVELOPMENT BLOCK GRANT (CDBG) FORMS

APPENDIX B – IRMA CONTRACTUAL INSURANCE GUIDELINES

APPENDIX C – VILLAGE OF VILLA PARK ORDINANCE 3733

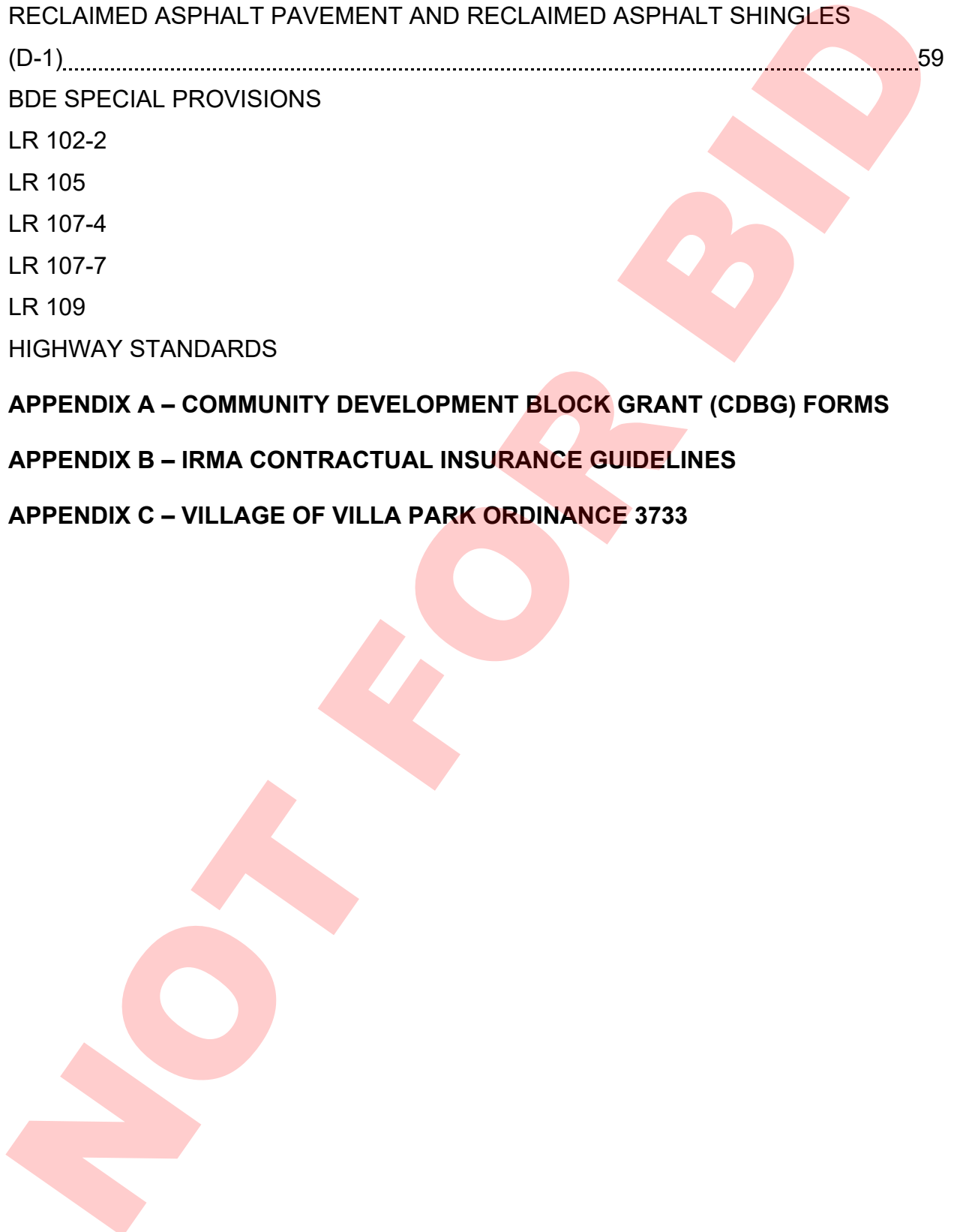

**SECOND AVENUE SEWER SEPARATION
VILLAGE OF VILLA PARK**

SPECIAL PROVISIONS

The following Special Provisions supplement the “Standard Specifications for Road and Bridge Construction”, adopted April 1, 2016 (referred to hereinafter as the Standard Specifications); the “Supplemental Specifications and Recurring Special Provisions”, adopted January 1, 2018; the latest edition of the “Illinois Manual on Uniform Traffic Control Devices For Streets and Highways” (IMUTCD); and the “Standard Specifications for Water and Sewer Construction in Illinois”, 7th Edition, 2014 (referred to hereinafter as the Water and Sewer Specifications). In case of conflict with any part or parts of said Specifications, these Special Provisions shall take precedence and shall govern. Where no conflict exists, the said Specifications shall apply to this Contract as if repeated in their entirety herein.

DEFINITIONS

Contractor. The individual, firm, partnership, joint venture, or corporation contracting with the Village of Villa Park for performance of prescribed work.

Department, Owner or Village. The Village of Villa Park, DuPage County, Illinois.

Engineer. The Resident Engineer who is the authorized representative of the Village of Villa Park in immediate charge of the engineering details of a construction project.

LOCATION OF PROJECT

This project is located on Second Avenue from Holly Court to Division Street in the Village of Villa Park.

DESCRIPTION OF PROJECT

This project consists of installing approximately 1,050 linear feet of storm sewer varying in size from 12” to 36”. The project also includes pavement removal, aggregate base course, Hot-Mix Asphalt Binder Course, Hot-Mix Asphalt Surface Course, curb and gutter removal and replacement, sidewalk removal and replacement, driveway pavement removal and replacement, adjusting sanitary services, adjusting water services, and landscape restoration.

GENERAL SPECIAL PROVISIONS

QUALIFICATIONS OF BIDDERS

Bidders will comply with all applicable Federal, State and local laws and requirements, and will further meet the qualifications prescribed in this and other applicable portions of these provisions.

Bidder, in submitting a Bid, certifies that Bidder is in compliance with all applicable Federal, State and local laws and requirements, and that Bidder further meets the qualifications prescribed in this and other applicable portions of these provisions. Engineer's determination as to the compliance and qualifications of the Bidder will be final, and Bidder, in submitting a Bid, agrees to be bound by that determination.

Bidder, in submitting a Bid, certifies that Bidder is in compliance with the following requirements and qualifications. Bidder further certifies that Bidder is able to provide written evidence of Bidder's compliance with the following requirements and qualifications. Bidder shall, upon request by Engineer, submit such written evidence within five (5) calendar days of the Engineer's request, as well as any other written evidence which Engineer may deem necessary for the purpose of evaluating Bidder's qualifications.

- (a) Bidder shall be qualified to do business in the State of Illinois.
- (b) Bidder shall possess either a valid Federal Employer Tax Identification Number (FEIN) or a valid Social Security Number (SSN).
- (c) Bidder shall be able to provide a street address and description of the Bidder's place of business, and the mailing address of the business, if different from the street address.
- (d) Bidder shall be able to provide the number of years Bidder has been engaged in the contracting business under the present firm name, and the name of the state where incorporated.
- (e) Bidder shall be able to provide a list of the property and equipment available to the Bidder.
- (f) Bidder shall be able to provide a financial statement demonstrating that the Bidder has the financial resources to meet all obligations related to the Work.
- (g) Bidder shall maintain insurance policies with the coverages required by the Contract, and with the minimum limits of coverage required by the Contract. Bidder shall be able to provide current certificate(s) of insurance for the

**SECOND AVENUE SEWER SEPARATION
VILLAGE OF VILLA PARK**

insurance policies held by Bidder, demonstrating that Bidder holds insurance policies with the coverages required by the contract, and with the minimum limits of coverage required by the Contract.

- (h) Bidder shall have constructed a minimum of three (3) projects of a similar nature in the immediate past five (5) years. Bidder shall be able to provide a list of all projects of a similar nature constructed by Bidder in the immediate past five (5) years, which list shall contain the minimum of three (3) such projects, which list shall provide a description and the location(s) of all such projects, and shall contain the Bidder's performance record and references, as well as the names and current contact information, including addresses and telephone numbers, of persons who acted as owners' representatives for those projects and who have knowledge of those projects, and whom Bidder agrees the Village may contact for the purpose of verifying Bidder's performance and references.
- (i) Bidder shall be able to provide a list of three (3) references (name, address and telephone number) with knowledge of the integrity and business practices of the bidder. Such references may not be persons who have been employed by Bidder as employees.
- (j) Bidder shall be able to provide a list of projects presently under Contract, the awarded Contract amount of each, the approximate adjusted Contract amount of each (if applicable), and the dollar amount or percent of completion of each.
- (k) Bidder shall be able to provide a list of Contracts which have resulted in lawsuits, whether against Bidder as a prime contractor, against Bidder as a subcontractor, or against Bidder as a party in any other capacity; or against subcontractors or suppliers performing work for Bidder or under Contract held by Bidder.
- (l) Bidder shall be able to provide a list of Contracts defaulted.
- (m) Bidder shall be able to provide a statement indicating whether or not Bidder has ever filed bankruptcy.
- (n) Bidder shall be able to provide a list of all officers of the firm, which list shall also indicate those officers who, while in the employ of the firm or in the employ of previous firms, were associated with Contracts which resulted in lawsuits, Contracts defaulted, or firms which filed for bankruptcy.
- (o) Bidder shall maintain personnel guaranteed to be employed in the responsible charge of the Work, which personnel possess sufficient technical experience to ensure the satisfactory completion of the Work. Bidder shall be

**SECOND AVENUE SEWER SEPARATION
VILLAGE OF VILLA PARK**

able to provide the names and technical experience of such personnel, as well as statements as to whether the personnel have or have not performed satisfactorily on other contracts of like nature and magnitude or comparable difficulty at similar rate of progress.

- (p) Bidder shall be able to provide a list of subcontractors and suppliers anticipated to be employed by Bidder for the purpose of completing the Work, including the firm name, street address and description of place of business; mailing address of business (if different); phone, fax and e-mail contact information of business; name of primary contact; and a list of any projects or contracts for which Bidder currently owes monies to said firm, which list shall include a description of the project or contract, the amount currently due to said firm, the period of time for which those monies have been owed, and the expected date of payment of those monies.
- (q) Bidder shall participate in active apprenticeship and training programs approved by and registered with the United States Department of Labor Bureau of Apprenticeship and Training for each of the trades of work contemplated under the Contract. Bidder shall be able to provide evidence of Bidder's participation in such apprenticeship and training programs.
- (r) Bidder shall only employ subcontractors who meet the requirements prescribed in this section and other sections of these specifications.
- (s) Bidder shall be able to provide such other information as may assist the Village in determining whether the Bidder is adequately prepared to fulfill the Contract.

These requirements and qualifications are not intended to discourage bidding, to make it difficult for qualified Bidders to submit Bids, or to discourage beginning contractors. The purpose of these requirements and qualifications is to allow the Village to obtain sufficient information about Bidder's financial state, available equipment, personnel, and previous work experience so that the Village may mitigate the hazards involved in awarding contracts to parties who may not be qualified to perform the Work as specified.

A copy of Village of Villa Park Ordinance No. 3733, amending the requirements of bidders for construction projects, is provided as Appendix C

SECOND AVENUE SEWER SEPARATION VILLAGE OF VILLA PARK

BID PRICE LIMITATIONS

The bid price for TRAFFIC CONTROL AND PROTECTION shall not exceed 5 percent of the total bid price. If the bid price for TRAFFIC CONTROL AND PROTECTION exceeds 5 percent of the total bid price, the Village may reject the Bid.

The bid price for CONSTRUCTION LAYOUT shall not exceed 2 percent of the total bid price. If the bid price for CONSTRUCTION LAYOUT exceeds 2 percent of the total bid price, the Village may reject the Bid.

The bid price for PRE-CONSTRUCTION VIDEO RECORDING shall not exceed 1 percent of the total bid price. If the bid price for PRE-CONSTRUCTION VIDEO RECORDING exceeds 1 percent of the total bid price, the Village may reject the Bid.

Bidder, in submitting a Bid, certifies that the Bid is in compliance with these requirements. The Village's determination as to whether or not to reject a Bid that does not comply with these requirements will be final, and Bidder, in submitting a Bid, agrees to be bound by that determination.

BIDS TO REMAIN SUBJECT TO ACCEPTANCE

All bids shall remain subject to acceptance by the Village for a period of 60 calendar days from the date of the bid opening. The Village may extend the acceptance period by up to an additional 60 calendar days upon written notice to all bidders by the Village. The Village may, in its sole discretion, release any bid and return the bid bond prior to the end of the acceptance period.

SUBCONTRACTORS

Add the following paragraph to the end of Article 108.01 of the Standard Specifications:

"The apparent low Bidder shall submit to the Village within 7 calendar days after the receipt of bids, a list of the names of Bidder's proposed subcontractors and material suppliers along with a description of the work to be performed or the materials to be supplied by each."

INSURANCE

Insurance and indemnification shall be in accordance with applicable sections of the Standard Specifications, and shall also be in accordance with the "IRMA Contractual Insurance Guidelines", incorporated herein as Appendix B. The Contractor shall name the Village of Villa Park, Christopher B. Burke Engineering, Ltd., and the County of

SECOND AVENUE SEWER SEPARATION VILLAGE OF VILLA PARK

DuPage, its officials, agents, employees and volunteers as additional insureds. If a conflict is determined to exist between the requirements prescribed in the Standard Specifications and the requirements prescribed in the IRMA Contractual Insurance Guidelines, such conflict will be resolved as follows:

- a. If a particular type of insurance coverage is required by one standard but not by both, that type of insurance coverage will be required.
- b. If the minimum limits of insurance coverage required by one standard differ from those required by the other standard, the higher minimum limits of insurance coverage will prevail.
- c. If any other conflicts are determined to exist between the requirements prescribed in the two standards, the stricter of the two requirements will prevail. The Village will make the final determination as to what constitutes a stricter requirement.

INCREASED OR DECREASED QUANTITIES

The Village reserves the right to increase or decrease the amount of work shown in the plans in accordance with Section 109 of the Standard Specifications.

MOBILIZATION

Mobilization shall be in accordance with Section 671 of the Standard Specifications, except as modified herein.

Revise Article 671.02, Basis of Payment, to read:

“671.02 Basis of Payment. This work will not be paid for separately but shall be included in the unit bid prices of the items for which this work applies.”

PORTABLE TOILET

Contractor shall furnish a portable toilet meeting Federal, State and local health department requirements stocked with lavatory and sanitary supplies at all times. The portable toilet shall be provided at a location approved by the Engineer. The portable toilet shall be maintained in a clean and sanitary condition and shall be emptied as needed. This work will not be paid for separately but shall be included in the cost of the contract.

**SECOND AVENUE SEWER SEPARATION
VILLAGE OF VILLA PARK**

WORKING HOURS

Working hours will be between 7:00 A.M. and 5:00 P.M., Monday through Friday, excluding holidays as designated by the Contract.

Contractor will not permit the performance of Work outside these working hours without Owner's written consent, which may be given after prior written request to Engineer, except as otherwise required for the safety of persons or the Work or property at the Site or adjacent thereto, and except as otherwise stated in the Contract Documents.

If Contractor permits the performance of Work outside these working hours, Contractor will compensate Owner for the costs of inspection and other services provided by Engineer. Owner will determine the rates at which such inspection and other services are to be compensated. Owner will determine the interval or intervals at which billing will take place, and may, at Owner's discretion, submit invoices for payment to Contractor, or deduct the costs from any monies due or to become due to the Contractor from Owner.

HOLIDAYS

Revise the list of legal holidays in Article 107.09 of the Standard Specifications to read:

New Year's Day	Thanksgiving Day
Easter	<u>Thanksgiving Friday</u>
Memorial Day	<u>Christmas Eve</u>
Independence Day	Christmas Day
Labor Day	<u>New Year's Eve</u>

PUBLIC CONVENIENCE AND SAFETY (D-1)

Effective: May 1, 2012
Revised: July 15, 2012

Add the following to the end of the fourth paragraph of Article 107.09:

"If the holiday is on a Saturday or Sunday, and is legally observed on a Friday or Monday, the length of Holiday Period for Monday or Friday shall apply."

Add the following sentence after the Holiday Period table in the fourth paragraph of Article 107.09:

"The Length of Holiday Period for Thanksgiving shall be from 5:00 AM the Wednesday prior to 11:59 PM the Sunday After"

SECOND AVENUE SEWER SEPARATION VILLAGE OF VILLA PARK

Delete the fifth paragraph of Article 107.09 of the Standard Specifications:

“On weekends, excluding holidays, on roadways with Average Daily Traffic of 25,000 or greater, all lanes shall be open to traffic from 3:00 P.M. Friday to midnight Sunday except where structure construction or major rehabilitation makes it impractical.”

OPERATION OF WATER DISTRIBUTION FACILITIES

Contractor shall not operate any water distribution facilities, including, but not limited to, valves or hydrants. If Contractor requires the operation of such facilities, Contractor shall provide a minimum of 48 hours notice to the Village and the Village will operate such facilities.

CONSTRUCTION SAFETY AND HEALTH STANDARDS

It is a condition of this contract and shall be made a condition of each subcontract entered into pursuant to this contract that the Contractor and any Subcontractor shall not require any laborer or mechanic employed in performance of that contract to work in surroundings or under working conditions which are unsanitary, hazardous or dangerous to their health or safety, as determined under Federal Construction Safety and Health Standards.

FINAL INSPECTION

Final inspection shall be in accordance with Article 105.13 of the Standard Specifications, except as modified herein.

Revise the second paragraph of Article 105.13, Final Inspection, to read:

“If the inspection discloses any work, in whole or in part, as being unsatisfactory, the Engineer will give the Contractor the necessary instructions for correction of same, and the Contractor shall comply with such instructions within 14 calendar days of receipt of such instructions. The Contractor shall give the Engineer not less than 48 hours notice, in writing, prior to beginning any such corrective work. Upon completion of all corrective work, the Contractor shall give the Engineer notice in writing. Upon receipt of such notice, the Engineer will make another inspection which shall constitute the final inspection provided the work has been satisfactorily completed. In such event, the Engineer will notify the Contractor in writing of the date of final inspection.”

SECOND AVENUE SEWER SEPARATION VILLAGE OF VILLA PARK

MAINTENANCE WARRANTY

The Contractor shall execute and deliver to the Village, before final payment will be issued, a written warranty, in a form satisfactory to the Village, which guarantees that all work is in accordance with the contract and will not be defective. This warranty shall guarantee all work for a period of 1 year from the date of final inspection.

The Contractor shall furnish a warranty bond in an amount equal to 10 percent of the final contract amount, or \$40,000, whichever is greater, by a surety satisfactory to the Village to guarantee Contractor's warranty to repair defective work.

If, within the warranty period, the Village determines any work to be defective, a written notice of such deficiency will be sent to the Contractor by certified mail.

The Contractor shall, within 14 calendar days of receipt of the notice of deficiency, and without cost to the Village, correct or repair such defective work, or remove and replace the defective work in accordance with the contract requirements for the item or items in question.

If Contractor desires an extension of time to complete the corrective work, Contractor shall make such request in writing within 10 calendar days of receipt of the notice of deficiency. After the Contractor has filed a request for an extension of time, the Village will notify the Contractor, in writing, whether or not such extension will be approved.

Should the Contractor fail to complete the corrective work within the 14 calendar days or within such extended time as may have been allowed, the Contractor shall be liable and shall pay to the Village the amount shown in the Schedule of Deductions for Each Day of Overrun in Contract Time, not as a penalty but as liquidated damages, for each day of overrun beyond the 14 calendar days or such extended time as may have been allowed.

MAINTENANCE OF ROADWAYS

Effective: September 30, 1985

Revised: November 1, 1996

Beginning on the date that work begins on this project, the Contractor shall assume responsibility for normal maintenance of all existing roadways within the limits of the improvement. This normal maintenance shall include all repair work deemed necessary by the Engineer, but shall not include snow removal operations. Traffic control and protection for maintenance of roadways will be provided by the Contractor as required by the Engineer.

SECOND AVENUE SEWER SEPARATION VILLAGE OF VILLA PARK

If items of work have not been provided in the contract, or otherwise specified for payment, such items, including the accompanying traffic control and protection required by the Engineer, will be paid for in accordance with Article 109.04 of the "Standard Specifications".

KEEPING ROADS OPEN TO TRAFFIC

All roads shall remain open to traffic unless otherwise shown on the contract plans. When necessary to close one lane because of construction, the Contractor shall maintain one-way traffic during construction hours with the use of signs and flaggers as shown on the Traffic Control Standards. Two lanes of traffic will be maintained during nights and weekends when no construction activities are being carried on.

Work under a separate contract may be ongoing adjacent to the project site during construction. Contractor shall coordinate schedules with all Contractors working in the area.

RESPONSIBILITY FOR VANDALISM

The Contractor shall be responsible for the protection of all equipment and materials. Any equipment or materials which are stolen, missing, damaged or vandalized shall be the Contractor's responsibility to repair or replace as needed at no additional cost to the contract.

The Contractor shall be responsible for the defacement of any concrete pours before they have set up. Concrete pavement, sidewalk, driveway, or curbing that has been defaced, in the opinion of the Engineer, shall be removed and replaced by the Contractor at Contractor's expense.

USE OF FIRE HYDRANTS

Revise Article 107.18, Use of Fire Hydrants, of the Standard Specifications to read:

107.18 Use of Fire Hydrants. If Contractor requires water for the completion of construction operations, and desires to obtain water from the Village, the Contractor shall make written application to the Village. If such application is approved by the Village, the Contractor shall obtain water from the fire hydrant located at 100 West Home Avenue, adjacent to the Village of Villa Park Fleet Maintenance Garage. Contractor's use of said hydrant and methods of obtaining water shall be in compliance with all applicable ordinances, rules, and regulations concerning such use. Contractor shall furnish all labor and equipment necessary to make a connection to said hydrant, and to obtain and transport water.

SECOND AVENUE SEWER SEPARATION VILLAGE OF VILLA PARK

Prior to obtaining water, Contractor shall make written application to the Village for temporary use of a hydrant meter. If the application for temporary use of a hydrant meter is approved, the Contractor shall provide a deposit of three-thousand dollars (\$3,000.00) to the Village for the temporary use of said hydrant meter, which deposit will be held by the Village until such time that the meter is returned to the Village by the Contractor in satisfactory condition. Contractor shall use said hydrant meter when obtaining water, and shall comply with all conditions for the use of said meter. Contractor shall return the hydrant meter to the Village within 24 hours of project completion and within 24 hours of any request by the Village that the hydrant meter be returned.

If Contractor makes application for temporary use of a hydrant meter and the application is not approved, Contractor shall make record of the quantity of water obtained, along with the date and time obtained, and shall report such information after each use to the Village of Villa Park Public Works Department, 11 West Home Avenue. If such use takes place outside of the normal working hours of the Public Works Department, Contractor shall report such information immediately upon the commencement of normal working hours.

Contractor shall not use, operate or obtain water from any hydrants other than the hydrant prescribed. Contractor shall not obtain water from the Village for construction operations or activities not under contract with the Village.

If a water main break occurs and the Village determines that the water main break is a result of Contractor's use of a hydrant, the Village may require the Contractor to repair the water main break in accordance with all applicable construction standards and requirements and at no cost to the contract, or may repair the water main break by other means and invoice the Contractor for reimbursement of the Village's costs.

Water usage will be measured according to the Special Provisions WATER USAGE DEDUCTION and WATER USAGE CREDIT."

TRENCH BACKFILL AND PIPE BEDDING

All trench backfill and pipe bedding materials furnished under this contract shall be virgin, non-recycled materials.

All trench backfill shall be crushed aggregate of CA-6 gradation. The aggregate material shall be placed in lifts not exceeding 8 in. in depth, loose measurement, and compacted by mechanical means to the satisfaction of the Engineer.

All pipes installed under this contract shall be placed on a bedding of crushed aggregate of CA-7 or CA-11 gradation having a minimum thickness of 4 in. The bedding shall be placed to a minimum of 12 in. above the top of the pipe and any fittings.

SECOND AVENUE SEWER SEPARATION VILLAGE OF VILLA PARK

The cost of furnishing and installing pipe bedding materials will not be paid for separately but shall be included in the cost of items to which this work pertains.

EXCAVATION AND BACKFILLING OF DRAINAGE AND UTILITY STRUCTURES

Excavation, bedding and backfilling of drainage and utility structures which are constructed, reconstructed, or adjusted as a part of this contract will not be paid for separately but shall be included in the cost of the items to which this work pertains.

SALVAGE AND DISPOSAL OF EXISTING MATERIALS

Existing manufactured materials which are removed and are not to be reused, including, but not limited to, frames, grates, lids, castings, sign posts, sign panels, fire hydrants, valves, stops, and fittings, shall remain the property of the Village unless the Engineer waives this requirement as specified herein.

Existing manufactured materials which are removed and are not to be reused will be inspected by the Engineer. Materials which are determined by the Engineer to be in satisfactory condition shall remain the property of the Village and shall be delivered by the Contractor to the Village of Villa Park Public Works Department yard located at 51 South Ardmore Avenue in Villa Park. Delivery shall be made during the normal working hours of the Village of Villa Park Public Works Department and the Contractor shall coordinate the day, time, and other details of delivery with the Village.

Materials which are determined by the Engineer to be in unsatisfactory condition shall become the property of the Contractor and shall be removed from the site by the end of the workday and properly disposed of by the Contractor.

The delivery or disposal of materials will not be paid for separately but shall be included in the cost of all items that include removal of existing materials.

FRAMES, GRATES AND LIDS

Frames, grates, lids and all other castings furnished under this contract shall be in accordance with Section 602 and Section 604 of the Standard Specifications, except as modified herein.

Castings shall conform to ASTM A48 Class 30. Castings shall be free of cracks, holes, swells, cold shuts, and patches. Castings shall not be coated or painted.

Frames, grates, lids and other castings shall be furnished in accordance with the following:

SECOND AVENUE SEWER SEPARATION VILLAGE OF VILLA PARK

Type 1 frames and closed lids shall be Neenah R-1713 self-sealing or approved equal.

Type 1 frames and open lids shall be Neenah R-1713 or approved equal.

Type 11 frames and grates located in barrier curb and gutter shall be Neenah R-3281-A with curb box or approved equal.

Type 11 frames and grates located in depressed curb and gutter shall be Neenah R-3281-A with depressed curb grate or approved equal.

All other castings not specified above shall be as shown on the plans or as directed by the Engineer. If any of the castings specified are not compatible in the field due to frame height or other constraints, the Contractor shall propose an alternate casting to the Engineer for approval and shall furnish the alternate casting if approved.

Frames, grates, lids and other castings located within curb ramps or crosswalks shall be substituted with ADA compliant castings.

All closed lid castings furnished under this contract shall be self-sealing, gasketed, watertight, and shall have machined bearing surfaces and concealed pick holes. The top surface of all closed lids shall be embossed with the words "VILLAGE OF VILLA PARK". The top surface of closed lids shall also be embossed with the word "SANITARY", "STORM", or "WATER" as appropriate.

Enviro-curb logos on curb boxes for Type 11 frames and grates shall have the words "DUMP NO WASTE" and "DRAINS TO RIVER" or "DRAINS TO WATERWAY" cast into the top of all curb boxes.

This work will not be paid for separately but shall be included in the cost of all pay items that include the furnishing of frames, grates, lids, or other castings.

DATE OF MANUFACTURE

All manufactured materials furnished under this contract, including, but not limited to, frames, grates, lids, castings, fire hydrants, pipe, drainage and utility structures, valves, stops, and fittings, shall have been manufactured no earlier than January 1 of the calendar year in which they are to be installed.

IRON AND STEEL MATERIALS

All iron and steel materials furnished under this contract shall be domestically manufactured or produced and fabricated in accordance with Article 106.01 of the

SECOND AVENUE SEWER SEPARATION VILLAGE OF VILLA PARK

Standard Specifications. The Contractor shall provide the necessary documentation to show that all steel for the project shall be manufactured in the U.S.A. and be less than one year old.

PROTECTION OF EXISTING DRAINAGE FACILITIES DURING CONSTRUCTION

Unless otherwise noted in the contract plans, the existing drainage facilities shall remain in use during the period of construction.

Locations of existing drainage structures and sewers, if shown on the contract plans, are approximate. Prior to commencement of work, the Contractor, at his/her own expense, shall determine the exact location of existing structures which are within the proposed construction site.

All drainage structures are to be kept free from any debris resulting from construction operations. All work and materials necessary to prevent accumulation of debris in the drainage structure resulting from construction operations shall be removed at the Contractor's own expense, and no extra compensation will be allowed.

Unless reconstruction or adjustment of an existing manhole, catch basin, or inlet is called for in the contract plans or ordered by the Engineer, the proposed work shall meet the existing elevations of these structures. Should reconstruction or adjustment of a drainage structure be required by the Engineer in the field, the necessary work and payment shall be done in accordance with Section 602 and Article 104.02 respectively, of the Standard Specifications.

Existing frames and grates are to remain unless otherwise noted in the contract plans or as directed by the Engineer. Frames and grates that are missing or damaged prior to construction shall be replaced. The type of replacements frame or grate shall be determined by the Engineer, and replacement and payment for same shall be in accordance with Section 604 and Article 104.02 respectively, of the Standard Specifications unless otherwise noted in the plans or special provisions.

PLUGGING EXISTING MANHOLES AND PIPES

This work shall consist of plugging holes in manholes where sewer pipes have been removed or abandoned as shown on the plans and as determined by the Engineer. The holes shall be plugged with brick and non-shrink concrete mortar to the satisfaction of the Engineer. The non-shrink concrete mortar shall completely fill the holes and keep all water from entering the manhole. When sewers to be removed or abandoned tie directly into a pipe, the pipe shall be plugged with non-shrink concrete mortar to the satisfaction of the engineer. The pipe shall be water-tight, and the inside of the pipe shall be free of excess material that might restrict flow.

**SECOND AVENUE SEWER SEPARATION
VILLAGE OF VILLA PARK**

All labor, materials, and equipment necessary to complete the work as specified herein shall not be paid for separately, but shall be included in the bid price for STORM SEWER REMOVAL.

PROJECT SIGN

Description: This work shall consist of furnishing, fabricating and installing project sign(s) in accordance with Section 720 of the Standard Specifications. The layout of the sign and the location of the sign shall be coordinated and approved by the VILLAGE prior to fabrication. Shop drawings of the sign and assembly shall be submitted to the ENGINEER for approval. This work shall also include posting a jobsite bulletin board at the project site to remain for the duration of the project. The bulletin board shall include emergency contact information, directions to the nearest hospital, and all applicable equal opportunity notices for employees required by the County.

Materials: The sign shall be 3 feet high and 4 feet wide constructed from 0.125 in. thick aluminum sheeting. The minimum letter height shall be 2 inches. The sign shall be fabricated using Type AP white sheeting for the background with black vinyl or black opaque ink for the letters and symbols. The bottom of the sign shall be six feet above ground. The sign shall be mounted using two Type A sign posts in accordance with Section 729 of the Standard Specifications.

DuPage County CDBG-DR Sign

The sign shall include the following language:

“Funding for this project has been provided, in part, by the DuPage Community Development Commission from the U.S. Department of Housing and Urban Development’s Community Development Block Grant – Disaster Recovery Program.”



SECOND AVENUE SEWER SEPARATION VILLAGE OF VILLA PARK

The sign shall be erected for the duration of construction. Upon completion of the project, the sign and posts shall be removed and shall remain property of the Village.

Method of Measurement and Basis of Payment: This work shall not be paid for separately, but shall be included in the cost of the contract. This work shall include all excavation, posts, restoration and all material, equipment, and labor required to complete the work specified herein.

IEPA CLEAN CONSTRUCTION AND DEMOLITION DEBRIS (CCDD)

All removal or excavation items being disposed of at an uncontaminated soil fill operation or Clean Construction and Demolition Debris (CCDD) fill site shall meet the requirements of Public Act 96-1416. All costs associated with meeting these requirements shall be included in the unit price cost for the associated removal or excavation items in the contract. These costs shall include but are not limited to all required testing, lab analysis, certification by a licensed professional engineer, and State and local tipping fees.

A copy of signed Illinois Environmental Protection Agency Form LPC 663 and associated reports can be accessed on the Village of Villa Park Public Works Website (www.invillapark.com/196/Public-Works-Department).

The CONTRACTOR is required to submit copies of all dump debris tickets to the ENGINEER.

PAVEMENT CORE, SOIL BORING, AND WASTE DISPOSAL REPORTS

Pavement cores, soil borings and waste disposal characterization was performed on Second Avenue by Testing Service Corporation. Summary reports of the pavement core, soil boring, and waste disposal characterization results can be accessed on the Village of Villa Park Public Works Website (www.invillapark.com/196/Public-Works-Department). The summary reports are for informational purposes only. Actual site conditions may vary.

PRICE QUOTATIONS AND CHANGE ORDERS

The CONTRACTOR will not be allowed a pre-established percentage rate for overhead and profit with any price quotation, whether initial or a change order. Cost-plus a percentage of cost and percentage of construction cost methods are prohibited from use on this project.

**SECOND AVENUE SEWER SEPARATION
VILLAGE OF VILLA PARK**

BRAND NAME POLICY

Neither the OWNER nor CONTRACTOR shall limit materials to only brand-name products. Non-brand name materials of equal specification do qualify and are acceptable.

MATERIAL AND EQUIPMENT STORAGE

The project site may have limited access and boundary constraints, all of which the Contractor accepts full responsibility. Any staging area(s) for materials, equipment, or other which are required by the Contractor shall be the responsibility of the Contractor.

If necessary, the Contractor shall enter into a separate contract with a private property owner which is outside the scope of this contract.

WORK ADJACENT TO FRANKLIN PARK

Franklin Park is located northeast of the intersection of Second Avenue and Elm Street, adjacent to the project site. The Contractor shall maintain a safe work zone and protect all material/equipment adjacent to the park. No material or equipment storage shall be allowed in the park. Any areas within the park disturbed due to construction activities shall be restored to the satisfaction of the Engineer, and at the expense of the Contractor.

The Contractor may be asked to adjust the work schedule around park events. The Village will provide the Contractor with a Parks Department event schedule at the pre-construction meeting.

CONSTRUCTION NOTICES

It shall be the CONTRACTOR's responsibility to distribute all construction notifications. This work will not be measured for payment but shall be included in the total contract cost. The construction notices shall be reviewed and approved by the ENGINEER prior to being distributed. Notices shall be issued at the following stages:

	<u>Activity</u>	<u>Notice Period Required</u>
1.	Prior to curb and driveway removal.	3 consecutive days prior
2.	Prior to water and sanitary service Interruption.	2 consecutive days prior
3.	Prior to pavement removal.	2 consecutive days prior
4.	Prior to paving.	2 consecutive days prior

**SECOND AVENUE SEWER SEPARATION
VILLAGE OF VILLA PARK**

The CONTRACTOR will also be responsible for distributing and/or redistributing notices in case of any delays due to inclement weather or for any other reason for extended stoppages (i.e. strikes) in the construction schedule.

Notices shall be considered distributed when all affected residents have received notices as well as a copy delivered and/or emailed to Public Works. The copy to Public Works shall be delivered the same day it is distributed to the residents.

Should the CONTRACTOR fail to distribute or post notices per the request of the VILLAGE, the CONTRACTOR shall not be allowed to start work on the given task until proper notification has been provided. No additional contract time will be allowed for compliance with this requirement.

NOT FOR BIDD

PAY ITEM SPECIAL PROVISIONS

PAY ITEM #2 – TREE TRUNK PROTECTION

Description. All work shall be in accordance with the applicable portions of Section 201 of the Standard Specifications.

At locations directed by the ENGINEER, the CONTRACTOR shall provide two (2") inch by six (6") inch by eight (8') foot boards banded continuously around each trunk to adequately prevent scarring of trees as marked on the plans or designated by the ENGINEER.

For multi-stem trees, or trees under six (6") inches in diameter, temporary fencing (snow fence) at the drip line will serve as trunk protection.

Method of Measurement and Basis of Payment. This work will be measured and paid for at the contract unit price per each for TREE TRUNK PROTECTION.

PAY ITEM #3 – TREE ROOT PRUNING

Description. This work shall consist of performing tree root pruning. This work shall be in accordance with Section 201 of the Standard Specifications, except as modified herein.

Fertilizer nutrients and supplemental watering will not be paid for separately, but shall be included in the cost of TREE ROOT PRUNING.

Method of Measurement. This work will be measured for payment as each per tree.

Basis of Payment. This work will be paid for at the contract unit price per each for TREE ROOT PRUNING.

PAY ITEM #6 – TRENCH BACKFILL

Description. The provisions of Section 208 of the "Standard Specifications for Road and Bridge Construction" shall be modified such that the material used for trench backfill shall be crushed limestone. The trench backfill shall be compacted only by Method 1, as defined in Article 550.07 of the Standard Specifications, which states the material shall be deposited in uniform layers not exceeding 150 mm (6 in) thick (loose measure), and each layer shall be compacted by ramming or tamping with tools approved by the ENGINEER. Jetting of the trench will not be an acceptable method of compaction. Material used as trench backfill shall be virgin, non-recycled materials.

**SECOND AVENUE SEWER SEPARATION
VILLAGE OF VILLA PARK**

Method of Measurement and Basis of Payment. This work shall be measured in place and paid for at the contract unit price per cubic yard for TRENCH BACKFILL.

PAY ITEM #8 – SODDING

Description. This work shall consist of preparing the ground surface, furnishing and applying topsoil to a maximum 4" depth, fertilizing the areas to be sodded, and furnishing and placing sod as specified in the plans. All work shall be in accordance with Sections 202, 211, and 252 of the Standard Specifications, and as specified herein.

CONTRACTOR shall locate all buffalo boxes and sanitary cleanouts prior to excavating for topsoil. CONTRACTOR shall place a 4' lath behind each box and cleanout to identify its location. A list of all b-boxes which cannot be found shall be provided to the ENGINEER.

Any excavation required to trim landscaped areas to the newly required grade shall be included in the cost of this item.

Excess spoil removed from parkways shall be immediately removed from the site and shall at no time be stored on the roadway. All sod shall be placed before the final roadway surface is installed.

The topsoil shall be free of large roots, brush, sticks, weeds, stones larger than 1/2" in diameter and any other litter. The topsoil shall be spread to a smooth compacted uniform thickness of not less than 4".

Fertilizer nutrients shall be applied in accordance with Section 252.03 of the Standard Specifications and shall be included in the cost for SODDING.

Method of Measurement and Basis of Payment. This work shall be measured in place and paid for at the contract unit price per square yard for SODDING.

PAY ITEM #10 – INLET FILTERS

Description. This work shall consist of installing, maintaining and cleaning inlet filters as shown on the plans or as directed by the Engineer. This work shall be in accordance with Section 280 of the Standard Specifications, except as modified herein.

Contractor shall inspect and clean all inlet filters weekly, after every rainfall, and additionally as needed. Maintenance and cleaning of inlet filters will not be paid for separately but shall be included in the cost of this work.

**SECOND AVENUE SEWER SEPARATION
VILLAGE OF VILLA PARK**

Method of Measurement and Basis of Payment. This work shall be measured and paid for at the contract unit price per each for INLET FILTERS.

PAY ITEM #15 – PORTLAND CEMENT CONCRETE DRIVEWAY PAVEMENT, 6 INCH

Description. This work shall consist of placing Portland Cement Concrete driveway pavement on a compacted aggregate base course in accordance with Sections 351 and 423 of the Standard Specifications, and as specified herein.

Driveway installation shall include Portland Cement Concrete installed to a minimum thickness of 6-inches and the placement and compaction of 4-inches of Aggregate Base Course, Type B on a compacted subgrade. The installation of Aggregate Base Course shall be included in the cost of the driveway pavement. If filling is required in the driveway subgrade, it shall consist of placing and compacting an approved granular material to the satisfactions of the ENGINEER.

All framing shall be set to final grade of the pour. No angle irons will be allowed. No watering cans shall be allowed on site.

The finish of the driveway shall match the driveway behind of the sidewalk. Where the finish behind the sidewalk is “california” or “letter box”, the contractor shall match this finish on the new apron. It shall be the contractor’s responsibility to verify the finish at each location. Installation of this finish shall be considered included in the cost of this item.

Method of Measurement and Basis of Payment. This work shall be measured in place and paid for at the contract unit price per square yard for PORTLAND CEMENT CONCRETE DRIVEWAY PAVEMENT, 6 INCH.

PAY ITEM #16 – PORTLAND CEMENT CONCRETE SIDEWALK 5 INCH

Description. This work shall consist of placing Portland Cement Concrete sidewalk on a compacted subbase in accordance with Sections 311 and 424 of the Standard Specifications, and as specified herein.

Sidewalk installation shall include Portland Cement Concrete installed to a minimum thickness of 5-inches and the placement and compaction of 4-inches of Subbase Granular Material, Type B on a compacted subgrade. Subbase Granular Material shall be included in the cost of the sidewalk. If filling is required in the sidewalk subgrade, it shall consist of placing and compacting an approved granular material to the satisfaction of the ENGINEER. Sidewalk thickness shall be increased to 6-inches when

SECOND AVENUE SEWER SEPARATION VILLAGE OF VILLA PARK

placed adjacent to driveways. Increasing sidewalk thickness at driveways shall not be paid for separately, but included in the cost of this item.

All framing shall be set to final grade of the pour. No angle irons will be allowed. No watering cans shall be allowed on site.

Method of Measurement. Portland Cement Concrete Sidewalk 5-inch shall be measured for payment in place, and the area computed in square feet.

Basis of Payment. This work will be paid for at the contract unit price per square feet for PORTLAND CEMENT CONCRETE SIDEWALK 5 INCH.

PAY ITEM #17 – DETECTABLE WARNINGS

Description. This work shall consist of installing detectable warnings. This work shall be in accordance with Section 424 of the Standard Specifications, except as modified herein.

Detectable warnings shall be installed at curb ramps and other locations where pedestrians are required to cross a hazardous vehicular way. Detectable warnings shall also be installed at alleys and commercial entrances where permanent traffic control devices are present.

Materials. Detectable warnings shall be pre-cast tiles. Installation shall be cast-in-place. Surface mounted applications will not be permitted. Detectable warnings shall be red in color. Detectable warning tiles shall be either rectangular or radial in shape as shown on the plans or as directed by the Engineer. The product or products to be used for detectable warnings shall be approved by the Engineer prior to use.

Construction. Installation shall be according to the manufacturer's specifications and as directed by the Engineer.

Where a curb ramp is 5 ft. in width or less and a rectangular detectable warning tile is to be used, the installation shall consist of a single detectable warning tile. If a pre-cast detectable warning tile is not manufactured in the width of the curb ramp, a larger detectable warning tile shall be furnished and shall be cut to the width of the curb ramp.

Installation of multiple detectable warning tiles at a single curb ramp will only be permitted where a curb ramp exceeds 5 ft. in width or where radial detectable warning tiles are to be used. Where multiple detectable warning tiles are permitted at a single curb ramp, they shall be mechanically joined prior to installation.

Method of Measurement. Detectable warnings will be measured for payment in place and the area computed in square feet.

**SECOND AVENUE SEWER SEPARATION
VILLAGE OF VILLA PARK**

Basis of Payment. This work will be paid for at the contract unit price per square foot for DETECTABLE WARNINGS.

PAY ITEM #18 – PAVEMENT REMOVAL

Description. This work shall consist of the removal and disposal of existing pavement, including all necessary excavation, as shown on the plans or as directed by the Engineer. This work shall be completed in accordance with Sections 202 and 440 of the Standard Specifications, except as modified herein.

Pavement removal shall include the removal of the entire existing pavement section and excavation (including stone, earth, clay, etc.) required to get down to the proper elevation for aggregate base course installation.

Method of Measurement and Basis of Payment. This work shall be measured and paid for at the contract unit price per square yard for PAVEMENT REMOVAL.

PAY ITEM #19 – DRIVEWAY PAVEMENT REMOVAL

Description. This work shall consist of the removal and disposal of existing driveway pavement, including all necessary excavation, as shown on the plans or as directed by the Engineer. This work shall be completed in accordance with Sections 202 and 440 of the Standard Specifications, except as modified herein.

Driveway pavement removal shall include the removal of existing driveway pavement and base course to the lines and grades shown on the plans and as directed by the Engineer. All excavation required to remove the base course shall be included in this item.

Method of Measurement and Basis of Payment. This work shall be measured and paid for at the contract unit price per square yard for DRIVEWAY PAVEMENT REMOVAL.

PAY ITEM #20 – COMBINATION CURB AND GUTTER REMOVAL

Description. This work shall consist of the removal and disposal of existing curb and gutter, including all necessary excavation, as shown on the plans or as directed by the Engineer. This work shall be in accordance with Sections 202 and 440 of the Standard Specifications, except as modified herein.

Excavation will not be paid for separately but shall be included in the cost of this item. The Contractor shall excavate all material necessary to build the proposed curb and

**SECOND AVENUE SEWER SEPARATION
VILLAGE OF VILLA PARK**

gutter subbase in accordance with Section 202 of the Standard Specifications. Excavated material will not be permitted to be stockpiled behind the curb.

Method of Measurement and Basis of Payment. This work shall be measured and paid for at the contract unit price per lineal foot of COMBINATION CURB AND GUTTER REMOVAL.

PAY ITEM #21 – SIDEWALK REMOVAL

Description. This work shall consist of the removal and disposal of existing sidewalk at locations shown on the plans or as directed by the Engineer. This work shall be completed in accordance with Sections 202 and 440 of the Standard Specifications, except as modified herein.

Excavation will not be paid for separately but shall be included in the cost of this item. The Contractor shall excavate all material necessary to meet the lines and grades shown on the plans and as directed by the Engineer. Additional excavation required to comply with ADA requirements shall be included in the cost of this item.

Method of Measurement and Basis of Payment. This work shall be measured and paid for at the contract unit price per square foot for SIDEWALK REMOVAL.

PAY ITEM #25 – DOMESTIC WATER SERVICE BOXES TO BE ADJUSTED

Description. This work shall consist of adjusting domestic water service boxes to match the proposed finished grade as directed by the ENGINEER, in accordance with Section 565 of the STANDARD SPECIFICATIONS.

Top sections, extensions and/or caps compatible with the existing box, may be required to adjust the box to the final grade. Replacement of damaged caps shall be considered included in this item.

For boxes which are located in sidewalks or driveways constructed as part of this improvement, the CONTRACTOR is responsible for confirming all caps and bolts can be opened after the concrete or asphalt has been placed. The CONTRACTOR shall confirm each roundway is keyable. If the CONTRACTOR cannot key the roundway, he shall notify the ENGINEER. After the work has been completed, the CONTRACTOR shall open each box in the presence of the ENGINEER.

Method of Measurement and Basis of Payment. This work shall be measured and paid for at the contract unit price per each for DOMESTIC WATER SERVICE BOXES TO BE ADJUSTED.

**SECOND AVENUE SEWER SEPARATION
VILLAGE OF VILLA PARK**

PAY ITEM #26 & 27 – CATCH BASINS, TYPE SPECIFIED

Description. This work shall consist of constructing Catch Basins, Type Specified at locations shown on the plans in accordance with the detail on the plan and Section 602 of the Standard Specifications, except as modified herein.

When a proposed catch basin is to be installed at the location of an existing drainage structure, the removal of the existing structure shall be included in this item.

Removing existing drainage structures shall consist of the removal and disposal of existing catch basins and inlets in accordance with Section 605 of the Standard Specifications. The word STRUCTURE shall be understood to mean catch basins and inlets as the case may be.

Method of Measurement and Basis of Payment. This work shall be measured and paid for per each for CATCH BASINS, TYPE SPECIFIED, frame and grate specified.

PAY ITEM #28, 29 & 30 – MANHOLE, TYPE A

Description. This work shall consist of constructing manholes at locations shown on the plans in accordance with the detail on the plan and Section 602 of the Standard Specifications, except as modified herein.

When a proposed manhole is to be installed at the location of an existing manhole, the removal of the existing structure shall be included in this item.

Removing existing manholes shall consist of the removal and disposal of existing manholes in accordance with Section 605 of the Standard Specifications.

Method of Measurement and Basis of Payment. This work shall be measured and paid for per each for MANHOLE, TYPE A, of the size and frame and grate specified.

PAY ITEM #35 – COMBINATION CONCRETE CURB AND GUTTER, TYPE B-6.12

Description. This work shall consist of the construction of combination concrete curb and gutter type B-6.12, including all necessary embankment as shown on the plans or as directed by the Engineer. This work shall be in accordance with the detail in the plans and Sections 606, 205, and 311 of the Standard Specifications, except as modified herein.

Backfill behind the proposed back of curb shall be in accordance with Section 205 of the Standard Specifications.

SECOND AVENUE SEWER SEPARATION VILLAGE OF VILLA PARK

Combination concrete curb and gutter shall be constructed on a prepared base of mechanically compacted crushed aggregate of CA-6 gradation having a minimum compacted thickness of 4 in.

Wood forms shall be used. Forms constructed of steel or Masonite will not be permitted. Forms for radius sections of the combination concrete curb and gutter shall be constructed of 1 in. thick wood boards.

The height of the curb head may vary as shown on the plans or as directed by the Engineer. Variations in the height of the curb head will not be paid for separately but shall be included in the cost of this item.

Where combination concrete curb and gutter is constructed across driveways, alleys, sidewalk curb ramps, or other designated areas, the top of the curb shall be depressed according to the details shown on the plans or as directed by the Engineer. The transition from full height curb to depressed curb shall be made over a distance equal to at least four times the difference in height between the full height curb and the depressed curb.

Where combination concrete curb and gutter is constructed across sidewalk curb ramps, the depressed curb shall be in compliance with all applicable requirements of the Americans with Disabilities Act (ADA) and the Proposed Guidelines for Accessible Rights-of-Way (PROWAG).

Expansion joints shall be constructed at 60 ft. maximum centers. Expansion joints shall also be constructed at all construction joints, all points of curvature, all points of tangency, within 5' on either side of all curb structure castings, and at additional locations as directed by the Engineer. Expansion joints shall consist of a 1 in. thick preformed bituminous expansion joint filler that extends the full cross section of the combination concrete curb and gutter. Expansion joint filler material that is larger than the cross section of the combination concrete curb and gutter shall be cut to the exact cross section of the combination concrete curb and gutter. Expansion joints shall have two 18 in. long, No. 6 non-deformed epoxy-coated steel dowel bars placed at mid-depth. The dowel bars shall have a greased plastic expansion cap placed on one end of each dowel bar a minimum of 1 in. from the end of the dowel bar.

Where proposed combination concrete curb and gutter is to be constructed abutting existing combination concrete curb and gutter, the dowel bars shall be drilled into the existing combination concrete curb and gutter. This work will not be paid for separately but shall be included in the cost of this item.

Contraction joints shall be constructed at 15 ft. maximum centers. Where the location of a contraction joint coincides with the location of an expansion joint, the contraction joint may be omitted at the discretion of the Engineer. Contraction joints shall be tooled and sawed. Sawing of contraction joints shall commence as soon as the concrete has

SECOND AVENUE SEWER SEPARATION VILLAGE OF VILLA PARK

hardened sufficiently to permit sawing without excessive raveling, but in no case shall sawing commence less than 4 hours or more than 24 hours after the concrete is placed. Sawing of contraction joints shall be to a depth equal to 1/3 the thickness of the gutter flag and to a width of not less than 1/8 in. Contraction joints shall be sealed according to Article 420.12, except that joints shall be sealed with polysulfide or polyurethane joint sealant.

If Contractor fails to construct joints in accordance with the requirements of this provision and the curb cracks, the Contractor shall remove and replace the affected section of combination concrete curb and gutter extending the full length between the two adjacent joints on either side of the crack. This work will not be paid for but shall be at the Contractor's expense.

Upon removal of the forms from the back of the combination concrete curb and gutter, excavated areas behind the combination concrete curb and gutter shall be immediately backfilled. Areas where pavement or sidewalks are to be constructed shall be backfilled with crushed aggregate of CA-6 or CA-7 gradation and mechanically compacted. Areas where topsoil and sodding are to be placed shall be backfilled with non-organic material acceptable to the Engineer. This work will not be paid for separately but will be included in the cost of this item.

Basis of Payment. This work will be paid for at the contract unit price per foot for COMBINATION CONCRETE CURB AND GUTTER, TYPE B-6.12.

PAY ITEM #37 – EXPLORATION TRENCH, SPECIAL

Description. This work shall consist of constructing a trench for the purpose of locating an existing utility or utilities. This work shall be in accordance with Section 213 of the Standard Specifications, except as modified herein.

The exploration trench may be used to locate existing utilities regardless of whether the utilities are public or private; known or unknown; or marked or unmarked. The exploration trench may also be used to determine the material type of existing utilities and to verify clearances between multiple utilities.

The exploration trench shall be constructed at the locations shown on the plans or as directed by the Engineer. The depth of the exploration trench shall vary as necessary, but shall be sufficient to locate the utility or utilities under investigation. The width of the trench shall be sufficient to allow proper investigation of the entire trench.

Method of Measurement. The exploration trench will be measured for payment in feet of actual trench constructed.

SECOND AVENUE SEWER SEPARATION VILLAGE OF VILLA PARK

Basis of Payment. This work will be paid for at the contract unit price per foot for EXPLORATION TRENCH, SPECIAL, regardless of the depth of the actual trench constructed.

PAY ITEM #38 & 39 – TEMPORARY ACCESS

Description. This work shall consist of the construction and maintenance of an aggregate base course for maintaining access to intersecting streets and driveways as specified in Article 107.09 of the STANDARD SPECIFICATIONS. The CONTRACTOR shall provide access for all emergency vehicles and school buses, and to all abutting properties at all times during construction.

Construction Requirements: The CONTRACTOR shall maintain ingress and egress to all abutting properties during construction operations when construction operations are not taking place directly in front of the property, except for a maximum period of 4 calendar days after new concrete curb or driveway pavement is poured. Residents shall be notified a minimum of 48 hours prior to this period. Temporary driveways and entrances shall be constructed of aggregate in accordance with the applicable portions of Section 351 of the STANDARD SPECIFICATIONS and to the dimensions determined by the ENGINEER. The coarse aggregate shall be crushed stone or crushed gravel, gradation CA-6. All adjacent properties shall have access at the end of each working day.

Maintenance shall consist of placing and compacting additional aggregate of the same type and gradation as the base aggregate.

After these driveway aprons have served their purpose, the suitable aggregate shall be removed, and, at the direction and approval of the ENGINEER, utilized for other purposes, such as aggregate base course for driveways, and embankment construction or other driveway aprons or otherwise disposed of as specified in Article 202.03 of the Standard Specifications.

Method of Measurement and Basis of Payment: This work will be paid for at the contract unit price per each for TEMPORARY ACCESS (PRIVATE ENTRANCE) or TEMPORARY ACCESS (ROAD). TEMPORARY ACCESS will only be measured and paid for once during construction. If work requires the temporary removal of aggregate for temporary access, it shall be stockpiled and replaced at the end of each working day at no additional cost to the Village.

PAY ITEM #40 – ADJUSTING WATER SERVICE LINES

Description. This work shall consist of adjusting existing copper water service lines which are determined by the Engineer to be in direct conflict with utilities being

SECOND AVENUE SEWER SEPARATION VILLAGE OF VILLA PARK

constructed under this contract. This work shall be in accordance with Section 563 of the Standard Specifications and with the Standard Specifications for Water and Sewer Construction in Illinois, except as modified herein.

Materials. Water service line pipe shall be Type "K" seamless copper water tubing conforming to ASTM B88. Water service line pipe shall be of the same diameter as the existing water service line to be adjusted.

Water service line couplings shall be Mueller H-15400 straight three-part unions with copper flare nuts on both ends, conforming to ANSI/AWWA C800, of the size needed. Components in contact with potable water shall comply with the latest requirements of the Federal Safe Drinking Water Act.

Construction. Where adjustment of the water service line above the utility in conflict will result in the water service line being less than 5.5 ft. below finished grade, the water service line shall be adjusted below the utility in conflict. If the water service line is to be adjusted below the utility in conflict, adjustment of the water service line shall be completed before the utility in conflict is constructed across the water service. If the water service line is to be adjusted above the utility in conflict, adjustment of the water service line may be completed either before or after the utility in conflict is constructed across the water service line.

The existing water service line shall be cut by an approved method. If adjustment of the water service line is not to be completed immediately, both ends of the water service line shall be crimped and bagged until adjustment is to be completed. The crimped ends shall be cut again by an approved method immediately before adjustment is to be completed.

The water service line shall be adjusted so that a minimum of 1 ft. of clearance exists in all directions between the water service line and all other utilities. A single piece of copper water tubing of sufficient length to provide the minimum clearances shall be utilized. The ends of the existing water service line shall be joined to the new copper water tubing with water service line couplings of the proper size.

The adjusted water service line shall be placed on a bedding of crushed aggregate of CA-7 or CA-11 gradation having a minimum thickness of 4 in. The bedding shall be placed to a minimum of 12 in. above the adjusted water service line.

Excavation, bedding, and backfilling needed to adjust water service lines will not be paid for separately, but shall be included in the cost of this work.

Method of Measurement. This work will be measured for payment as each water service line adjusted, regardless of the length of the water service line adjusted, the depth of the water service line adjusted, the diameter of the water service line adjusted,

**SECOND AVENUE SEWER SEPARATION
VILLAGE OF VILLA PARK**

or any other factors. No separate measurement will be made of pipe, fittings, couplings, stops, valves, or other components.

Basis of Payment. This work will only be paid for if the Engineer determines the water service line is in direct conflict with a utility or utilities being constructed under this contract. If the Engineer determines the water service line is in direct conflict with a utility or utilities being constructed under this contract, then this work will be paid for at the contract unit price per each for ADJUSTING WATER SERVICE LINES. If Contractor elects to adjust a water service line that the Engineer has not determined to be in direct conflict, that work will not be paid for but shall be at the Contractor's expense.

PAY ITEM #41 – TRAFFIC CONTROL AND PROTECTION (SPECIAL)

Traffic control shall be in accordance with the applicable sections of the Standard Specifications, the "Illinois Manual on Uniform Traffic Control Devices for Streets and Highways", any special details and Highway Standards contained in the plans, and the Special Provisions contained herein.

Special attention is called to Article 107.09 of the Standard Specification and the following Highway Standards, Details, Quality Standard for Work Zone Traffic Control Devices, Recurring Special Provisions and Special Provisions contained herein, relating to traffic control.

The Contractor shall contact the VILLAGE at least 72 hours in advance of beginning work.

STANDARDS: 701301-04, 701501-06, 701801-06, 701901-07

DETAILS: Traffic Control and Protection for Sideroads, Intersections, and Driveways (TC-10), District One Typical Pavement Marking (TC-13)

SPECIAL PROVISIONS: Maintenance for Roadways, Work Zone Traffic Control, and Flaggers in Work Zones.

Basis of Payment. This work shall be paid for at the contract unit price per lump sum for TRAFFIC CONTROL AND PROTECTION (SPECIAL).

PAY ITEM #42 – HOT-MIX ASPHALT DRIVEWAY PAVEMENT, 4"

Description. Work under this item consists of construction of new HMA driveway pavement at locations shown on the plans, or as directed by the ENGINEER, in

**SECOND AVENUE SEWER SEPARATION
VILLAGE OF VILLA PARK**

accordance with Sections 301, 351, 406 and 423 of the Standard Specifications and as directed by the ENGINEER.

CONTRACTOR shall place embankment or excavate in accordance with Sections 202 and 205 of the Standard Specifications in order to achieve the required finished grades.

The proposed driveway pavement shall consist of 1 lift of 2.5" HMA Binder Course, IL-19.0, N50 and 1 lift of 1.5" HMA Surface Course, Mix D, N50 for a total of 4" of HMA over 6" of mechanically compacted Aggregate Base Course, Type B. The existing aggregate base course may be re-used with approval of the ENGINEER.

All excavation, embankment, HMA Surface Course, and aggregate base course will not be paid for separately but shall be included in this pay item.

Basis of Payment. This work shall be measured in place and paid for at the contract unit price per square yard for HOT-MIX ASPHALT DRIVEWAY PAVEMENT, 4".

PAY ITEM #44 – DRAINAGE STRUCTURE TO BE REMOVED

Description. This work shall consist of removing and disposing of existing catch basins and inlets in accordance with Section 605 of the Standard Specifications and as specified herein. The word STRUCTURE shall be understood to mean catch basins and inlets as the case may be. Removal of existing structures in locations where new structures are to be installed shall be included in the cost of the proposed structure.

Construction Requirements. In addition to the requirements of Article 605.03 of the Standard Specifications, the Contractor shall saw cut a square area around the structure to be removed of sufficient size to remove the structure. Excavated areas around the structure shall be backfilled with mechanically compacted CA-6. This backfill shall be included in the cost for DRAINAGE STRUCTURE TO BE REMOVED.

Method of Measurement and Basis of Payment. This work shall be measured and paid for at the contract unit price per each for DRAINAGE STRUCTURES TO BE REMOVED.

PAY ITEM #45 – STORM SEWERS (WATER MAIN REQUIREMENTS)

Description. This work shall conform to Section 550 of the Standard Specifications.

STORM SEWERS (WATER MAIN REQUIREMENTS) shall comply with Illinois Environmental Protection Agency, Division of Public Water Supplies "Technical Policy Statements" concerning Illinois Pollution Control Board Rules and Regulations, Chapter

SECOND AVENUE SEWER SEPARATION VILLAGE OF VILLA PARK

6, Rule 212, E through F. The following materials are permitted for STORM SEWER (WATER MAIN REQUIREMENTS):

1. PVC pressure pipe and fabricated fittings (water main quality) in accordance with AWWA C-900 for sizes 4"-12" or AWWA C-905 for sizes 14"-48". PVC pipe joints shall be flexible elastomeric seals per ASTM D-3212 and F-477.
2. Ductile Iron pipe (Class 52) conforming to ANSI/AWWA C151/A.21.51 with joints conforming to ANSI/AWWA C111/A.21.11. Ductile shall be encased in polyethylene encasement in accordance with ANSI/AWWA C105/A21.5.

The storm sewers shall be handled in such a manner as to prevent damage to the pipe or joint/gasket. Accidental damage to the pipe or joint/gasket shall be repaired to the satisfaction of the ENGINEER, or be removed from the job, and the methods of handling shall be corrected to prevent further damage when called to the attention of the CONTRACTOR.

The pipe shall be inspected by the ENGINEER for defects prior to installation. Dirt or other foreign material which might prevent a watertight seal between pipe sections shall be removed to the satisfaction of the ENGINEER prior to installation. If any pipe end or gasket has been installed with dirt or foreign material therein, it shall be removed, cleaned and reinstalled.

Method of Measurement and Basis of Payment. This work shall be paid for at the contract unit price per lineal foot for STORM SEWERS (WATER MAIN REQUIREMENTS) of the diameter specified.

PAY ITEM #46 & 47 – ADJUSTING SANITARY SEWERS, 8-INCH DIAMETER OR LESS

Description. This work shall consist of adjusting sanitary sewers of 8-inch diameter or less where the proposed utility is in direct conflict with the existing sanitary sewer or service, as determined by the ENGINEER, in accordance with Section 563 of the Standard Specifications and as specified herein.

Materials. Sanitary sewer shall be PVC, SDR 26 conforming to ASTM D2241. Connections to existing sanitary sewer main or service pipe shall be made with stainless steel non-shear mission couplings, gasket to meet ASTM C1173-91, 300 series stainless steel shear ring with a minimum thickness of 0.012", 316 grade stainless steel nut and bolt tightening clamps, shear ring and clamps to meet all requirements of ASTM A167-91, transitional sizes to utilize a one-piece gasket. Segments of sanitary services located below the proposed utility shall be constructed

SECOND AVENUE SEWER SEPARATION VILLAGE OF VILLA PARK

with Class 52 ductile iron pipe. The length of ductile iron pipe shall be determined in the field by the engineer.

Construction Requirements. For instances where the existing sanitary sewer service pipe is excavated and found to be 4-inches in diameter, or less, the sewer service pipe shall be replaced with 6-inch PVC, SDR 26 or ductile iron, class 52, between the wye or tee connection at the sewer main and the cleanout connection at the property line, or as otherwise directed by the Engineer. Connection to the existing 4-inch (or less) diameter sewer service pipe shall be made using a transitional coupling in conformance with the requirements specified above.

Method of Measurement and Basis of Payment. This work will only be paid for if the Engineer determines the sanitary sewer or service line is in direct conflict with a utility or utilities being constructed under this contract. This work shall be measured and paid for at the contract unit price per foot for ADJUSTING SANITARY SEWERS, 8-INCH DIAMETER OR LESS for PVC segments, and ADJUSTING SANITARY SEWERS, 8-INCH DIAMETER OR LESS – DUCTILE IRON for ductile iron segments.

PAY ITEM #48 – BRICK DRIVEWAY REMOVAL AND REPLACEMENT

Description. This work shall consist of removing an existing brick driveway, cleaning and storing the bricks, excavating or placing embankment to meet the lines and grades shown on the plans, and replacing the bricks in the original pattern to the satisfaction of the Engineer. This work shall be completed in accordance with Sections 301 and 440 of the Standard Specifications, and as directed by the Engineer.

If the Contractor removes or damages the existing driveway outside the limits designated by the Engineer, the Contractor will be required to remove and replace that portion at the Contractor's own expense to the satisfaction of the Engineer. The existing material shall be carefully stored and replaced after the adjacent curb and gutter or sidewalk is completed. In some locations, the Contractor may have to provide additional material. The additional brick, pavers or flagstone must match the existing and be approved by the Engineer before installation. The Contractor shall provide a 4" thick sand base or equal to the thickness of the existing base whichever is greater. This work will not be paid for separately but shall be included in this pay item.

All excavation, embankment, brick, stone, aggregate base course, sand, and any other material required to match the existing brick driveway shall be included BRICK DRIVEWAY REMOVAL AND REPLACEMENT.

Method of Measurement and Basis of Payment. This work shall be measured and paid for at the contract unit price per square yard for BRICK DRIVEWAY REMOVAL AND REPLACEMENT.

**SECOND AVENUE SEWER SEPARATION
VILLAGE OF VILLA PARK**

PAY ITEM #49 – CONTINGENCY ALLOWANCE

Description. A contingency allowance pay item is provided as a part of this contract for the purpose of facilitating the completion of unforeseen or additional work not included in the contract as awarded, and which is determined by the Engineer to be necessary and germane to the contract.

Use of the contingency allowance will be at the discretion of the Engineer. The Engineer may, at the Engineer's discretion, use the contingency allowance for any of the following reasons:

- (a) Facilitate a temporary payment allowance to the Contractor for work completed under existing contract pay items and for which completed quantities exceed contract quantities;
- (b) Facilitate a temporary payment allowance to the Contractor for work completed beyond the scope of existing contract pay items; or
- (c) Facilitate a temporary payment allowance to the Contractor for the purchase of equipment, materials or such other requisition as Engineer determines to be necessary for the completion of the Work.

Such use of the CONTINGENCY ALLOWANCE will be further subject to approval by the Village. The Village's decision with regard to use of the CONTINGENCY ALLOWANCE will be final.

- A. Any payments made to Contractor under the CONTINGENCY ALLOWANCE will be considered temporary, and will only be retained by Contractor until such time that an authorization of contract changes can be approved and incorporated into the contract.
- B. Contractor, in accepting payments made under the CONTINGENCY ALLOWANCE, agrees to the terms of this and other applicable special provisions. Contractor agrees to relinquish any monies and any claim to monies paid under the CONTINGENCY ALLOWANCE upon approval of an authorization of contract changes and payment for any work for which payment was previously made under the CONTINGENCY ALLOWANCE. Contractor further agrees to return any monies previously paid thereunder.
- C. The CONTINGENCY ALLOWANCE pay item for this contract has been established with a unit of measurement in dollars, a quantity of 25,000.00, and a contract unit price of one dollar (\$1.00), for a total CONTINGENCY ALLOWANCE contract price of twenty-five thousand dollars and no cents (\$25,000.00). Bidder, in submitting a bid, accepts the quantity, contract unit price, and total contract price of the CONTINGENCY ALLOWANCE.

SECOND AVENUE SEWER SEPARATION VILLAGE OF VILLA PARK

Basis of Payment. This work will be paid for at the contract unit price per dollar for CONTINGENCY ALLOWANCE. The total bid amount for this item will be \$25,000.00.

PAY ITEM #50 – PRE-CONSTRUCTION VIDEO RECORDING

Description. This work shall consist of performing color video and audio recording of the project area and other areas which may be impacted by construction.

Pre-construction video recordings will include coverage of the project area and all other areas which may be impacted by construction. Video recordings will also include construction easements when applicable. Video recordings will provide a visual record of all physical features within those areas, including, but not limited to, roadways, pavements, curbs, gutters, driveways, driveway aprons, sidewalks, carriage walks, parkways, trees, landscaping, shrubbery, plantings, landscaping walls, retaining walls, signs, sign posts, fences, utility poles, light poles, utilities, equipment, manholes, b-boxes, cleanouts, valves, curb structures, pipelines, buildings, mailboxes, and any other features located within the project area.

Video recordings will begin with an audio narrative which provides the current date and time, the name of the Village and name of project, and a description of both the starting location and the location or locations to be recorded, including street name or names, street addresses, and any additional information which may be necessary to describe the location and subject of viewing.

Video recordings will maintain viewer orientation by means of an audio commentary in the audio track of each video recording which provides an explanation of what is being viewed; and by videotaping landmarks and readily identifiable objects, including property addresses, street signs, or other appropriate objects, at appropriate intervals.

Pre-construction video recordings will be recorded at a rate of travel not exceeding 50 feet per minute, and zooming and panning rates will be controlled to provide clarity of features during playback. The finished product will be provided with bright, clear pictures and accurate colors free from distortion, tearing, rolls, or other forms of picture imperfection. The audio will have proper volume and clarity. All recordings will be performed at times of satisfactory visibility, and when no more than 10 percent of ground is obscured by snow, leaves, or other cover.

If any element within or portion of the project area is not adequately documented by the pre-construction video recording so as to definitively demonstrate its condition prior to the start of construction, Contractor will assume responsibility for the repair, restoration or replacement of that element or portion of the project area. Such repair, restoration or replacement will be to equal or better condition than previously existing, and will further comply with all standards and provisions which govern the work in question.

SECOND AVENUE SEWER SEPARATION VILLAGE OF VILLA PARK

Schedule. Preconstruction video recording will be performed according to the following schedule:

- (a) Pre-construction video recording will be completed after a Notice to Proceed has been issued.
- (b) Pre-construction video recording will be completed after the Joint Utility Locating Information for Excavators (JULIE) request for the project area has cleared.
- (c) Pre-construction video recording will be completed before any equipment, materials, or other items are delivered to the site.
- (d) Pre-construction video recording will be completed no more than 7 chargeable days prior to the start of construction.
- (e) Pre-construction video recording will be completed, the required pre-construction video recording deliverables will be submitted to the Engineer, and the Engineer will review and issue written approval of the pre-construction video recording before any activity other than utility locating will be permitted to start. Such activity will include, but not be limited to, delivery of materials and equipment, installation of traffic control and erosion control, and completion of construction layout and tree protection. No days will be charged against the contract time while the video is under review by the Engineer, including the day the deliverables are submitted and the day a response is provided. If the pre-construction video recording or any portions thereof are rejected, the contract time will commence to run until revisions are submitted.
- (f) Pre-construction video recording will be submitted to Engineer for review prior to commencement of any construction, and receive acceptance of recordings prior to commencement of construction. Any areas found not acceptable to the Owner will be re-recorded at no additional cost to the contract.

Deliverables. Video will be high-definition, with a minimum resolution of 1280 × 720 pixels per frame. Video will be filmed in a landscape aspect ratio. Video filmed in a portrait aspect ratio will be considered unacceptable and will be rejected.

Preconstruction video recordings will be provided as electronic files of .avi, .mp4, .m4v, .mkv, .wmv, or .mpg file format, or of such other file format as may be approved by Engineer. Preconstruction video recordings will be provided as independent digital container format files, which container files will include all video, audio, and other electronic information necessary to view the preconstruction video recording as intended.

**SECOND AVENUE SEWER SEPARATION
VILLAGE OF VILLA PARK**

Video DVD will be considered an unacceptable format for providing preconstruction video recordings, and will be rejected.

Pre-construction video recording electronic files will be provided on a portable electronic media device or devices of one of the following types: USB flash drive, SD flash memory card, CF flash memory card, data DVD, external hard drive, or such other portable electronic media device as may be approved by Engineer. Preconstruction video recording electronic files may also be provided via online file sharing, cloud storage, File Transfer Protocol (FTP), or other online or network file transfer methods if approved by Engineer.

Pre-construction video recording electronic files will be accompanied by corresponding logs which document the dates, times, and locations covered by each preconstruction video recording electronic file.

Contractor shall maintain copies of all items submitted to Engineer for Contractor's own use and record.

Method of Measurement. This work will be measured for payment on a lump sum basis. No measurement will be made of the individual components of this effort.

Basis of Payment. Pre-construction video recording will be paid for at the contract lump sum price for PRE-CONSTRUCTION VIDEO RECORDING.

PAY ITEM #51 – SANITARY MANHOLE, TYPE A, 4'-DIAMETER, TYPE 1 FRAME, CLOSED LID

Description. This work shall consist of constructing manholes, together with the necessary cast iron frames and lids, in accordance with the detail in the plans and Section 602 of the STANDARD SPECIFICATIONS, except as specified herein.

Manholes constructed over proposed or existing sanitary sewers and which are indicated on the plans as sanitary manholes shall be provided with rubber gasketed couplings to ensure a watertight seal between pipe and manhole. The rubber gasketed couplings shall conform to ASTM Specification C-923. Manholes shall be provided with epoxy coated cast iron steps on 16" centers from frame to invert. The outside of the manhole shall be coated with a waterproofing membrane and external sealing bands conforming to ASTM C-877. The seal between the pipe and the structure to be bound by water tight hydraulic cement. The rubber gasketed couplings, waterproof coating, chimney seal, and steps shall be included in the cost of manholes and will not be paid for separately.

Manholes constructed in a location where an existing manhole was removed shall include five feet of pipe for each existing pipe location. Sanitary sewer pipe shall be

SECOND AVENUE SEWER SEPARATION VILLAGE OF VILLA PARK

PVC, SDR 26 conforming to ASTM D2241 or ductile iron, class 52, connections shall be made with non-shear mission couplings. The pipe, collar, couplings, and trench backfill shall be included in the cost of manholes and will not be paid for separately.

When a proposed manhole is to be installed at the location of an existing manhole, the removal of the existing structure shall be included in this item. Removing existing manholes shall consist of the removal and disposal of existing manholes in accordance with Section 605 of the Standard Specifications.

Method of Measurement and Basis of Payment. This work shall be paid for at the Contract unit price per each for SANITARY MANHOLE, TYPE A, 4' DIAMETER, TYPE 1 FRAME, CLOSED LID.

PAY ITEM #52 – SANITARY SERVICE CONNECTION

Description. This work shall consist of replacing existing sanitary service connections at locations of sanitary service removal and replacement. The work shall be done in accordance with applicable portions of Section 563 of the Standard Specifications and as specified herein.

The exact locations of existing sewer and sewer connections are to be verified in the field by the CONTRACTOR. The Village will not mark locations of existing sanitary services.

The CONTRACTOR shall install a new polyvinyl chloride tee fitting at the location of the connection to the existing sewer main, and shall remove and replace, if necessary, a sufficient length of existing service pipe to re-establish the service. All connections to existing pipes shall be made with non-shear mission couplings. The couplings shall be equipped with stainless steel bands. All associated costs shall be included in the contract unit price for the sanitary sewer service connection.

Basis of Payment. This work will be paid for at the contract unit price per each for SANITARY SERVICE CONNECTION.

PAY ITEM #53 – SANITARY SERVICE REPLACEMENT

Description: This work shall consist of the complete removal or abandonment of existing service as directed by the ENGINEER and replacing and reconnecting a new PVC, SDR-26 (ASTM D2241) sanitary service to the existing sanitary sewer.

New sanitary service pipe should be cut in cleanly at the minimum distance from the conflicting improvement that provides for elimination of the conflict, or a location determined by the ENGINEER. A rubber, non-shear mission coupling with stainless

SECOND AVENUE SEWER SEPARATION VILLAGE OF VILLA PARK

steel bands should be used to effect the connection between new service and existing service pipes.

Sanitary services shall be connected to the existing sanitary sewer where shown on the plans. The exact locations of existing sewer and sewer connections are to be verified in the field by the CONTRACTOR. The Village will not mark locations of existing sanitary services, and the locating of existing services shall be the responsibility of the CONTRACTOR. The slope from the right-of-way to the sewer connection shall be continuous and constant, except as otherwise authorized by the ENGINEER. The CONTRACTOR shall be responsible for verifying the elevation and slope of the proposed service prior to the installation of each service.

The CONTRACTOR shall install a new polyvinyl chloride tee fitting at the location of the connection on the mainline sanitary sewer. Installation of this fitting shall be paid for as SANITARY SERVICE CONNECTION. The services shall be replaced from the new fitting at the mainline sanitary sewer to the right-of-way line, using SDR-26 polyvinyl chloride pipe conforming to ASTM D2241 of the same diameter as the existing connection. The CONTRACTOR is to ensure positive flow from the right-of-way to the connection to the mainline sewer.

Backfill shall be in accordance with Section 208 of the Standard Specifications and shall be paid for as TRENCH BACKFILL.

Method of Measurement and Basis of Payment. Pay limits for removal and replacement of sanitary services for this item shall extend from the connection at the sanitary main to the existing right-of-way. This work will be measured and paid for at the contract unit price per foot for SANITARY SERVICE REPLACEMENT.

PAY ITEM #54 – SANITARY SEWER SERVICE COMBINATION CLEANOUT CHECK VALVE

Description. This work shall consist of furnishing and installing a combination cleanout check valve on a new or existing sanitary sewer service line at the locations shown in the plans or as directed by the Engineer. This work shall be in accordance with Section 563 of the Standard Specifications and with the Standard Specifications for Water and Sewer Construction in Illinois, except as modified herein.

This work may consist of either the standalone installation of a combination cleanout check valve on an existing sanitary sewer service line, or the installation of a combination cleanout check valve on a new sanitary sewer service line in conjunction with the installation of the new sanitary sewer service line.

Materials. Combination cleanout check valves shall be RectorSeal Clean Check Extendable Backwater Valve, 6" PVC, Model #31805, or approved equal.

SECOND AVENUE SEWER SEPARATION VILLAGE OF VILLA PARK

Cleanout riser pipes shall be shall be polyvinyl chloride (PVC) of the diameter and type required.

Sanitary sewer service line pipe shall be polyvinyl chloride (PVC) conforming to ASTM D-2241 with a Standard Dimension Ratio (SDR) equal to 26 and gasketed joints conforming to ASTM D-3212. Sanitary sewer service line pipe shall be of the same diameter as the sanitary sewer service line on which the combination cleanout check valve is to be installed. All supplied pipe shall be from the same manufacturer.

Pipe couplings shall be Fernco Shielded RC Series Couplings, Mission Rubber Company Flex-Seal ARC Sewer Repair Couplings, or approved equal. Pipe couplings shall be non-shear and shall be equipped with stainless steel bands.

Construction. The combination cleanout check valve shall be located a minimum of 4 ft. behind the back of curb. The height of the combination cleanout check valve riser pipe shall be such that the cap of the combination cleanout check valve is level with finished grade.

The combination cleanout check valve shall be assembled and installed in accordance with the manufacturer's specifications. Contractor shall provide all materials, fittings, and adapters necessary to assemble the combination cleanout check valve and to connect it to the sanitary sewer service line.

Following installation, the combination cleanout check valve shall be tested by the Contractor to confirm that there is positive flow through the sanitary sewer service line and combination cleanout check valve towards the sanitary sewer main.

Excavation, bedding, and backfilling will not be paid for separately but shall be included in the cost of this work.

Method of Measurement. This work will be measured for payment as each combination cleanout check valve installed, regardless of the depth, whether the cleanout check valve is installed on an existing sanitary sewer service line or a new sanitary sewer service line, or any other factors. No separate measurement will be made of pipe, fittings, couplings, other components.

Basis of Payment. This work will be paid for at the contract unit price per each for SANITARY SEWER SERVICE COMBINATION CLEANOUT CHECK VALVE.

PAY ITEM #55 – STORM SEWERS, CLASS B (PVC), 6”

Description. This work shall consist of constructing Polyvinyl Chloride (PVC) pipe storm sewers on granular bedding as shown on the plans in accordance with the detail

SECOND AVENUE SEWER SEPARATION VILLAGE OF VILLA PARK

in the plans, Sections 550 and 1040.03 of the Standard Specifications, and as specified herein.

Materials. Storm sewers shall be Polyvinyl Chloride (PVC), SDR 26 pipe in accordance with ASTM D2241 and Section 1040.03 of the Standard Specifications. Bedding material shall be crushed gravel or stone meeting gradation CA-7 or CA-11.

Construction Requirements. Storm sewers shall be installed on a minimum of 4-inches of granular bedding. Once the pipe has been installed the Contractor shall place bedding to 12-inches over the crown of the pipe. Bedding material will not be paid for separately but shall be included in the cost of this item. The Contractor shall connect the proposed storm sewer to existing storm sewer or a drainage structure at the direction of the Engineer. The method of connection shall be approved by the Engineer prior to construction. The connection of the proposed storm sewer to the drainage system shall be included in the cost of the proposed pipe.

If required by the Engineer, the Contractor shall stabilize the trench bottom by replacing unsuitable material with CA-1 limestone. This will not be paid for separately but shall be included in this item.

Trench backfill shall be placed over the bedding material and shall be paid for as TRENCH BACKFILL.

Method of Measurement and Basis of Payment. This work shall be measured and paid for at the contract unit price per lineal feet for STORM SEWERS, CLASS B (PVC), 6".

PAY ITEM #56, 57, & 58 – STORM SEWERS, RUBBER GASKET, CLASS A (RCP)

Description. This work shall consist of constructing reinforced concrete pipe storm sewers on granular bedding as shown on the plans in accordance with the detail in the plans, Sections 550 and 1042 of the Standard Specifications, and as specified herein.

Materials. Storm sewers shall be reinforced concrete pipe in accordance with Section 1042 of the Standard Specifications. Bedding material shall be crushed gravel or stone meeting gradation CA-7 or CA-11.

Construction Requirements. Storm sewers shall be installed on a minimum of 4-inches of granular bedding. Once the pipe has been installed the Contractor shall place bedding to 12-inches over the crown of the pipe. Bedding material will not be paid for separately but shall be included in the cost of this item.

Trench backfill shall be placed over the bedding material and shall be paid for as TRENCH BACKFILL.

SECOND AVENUE SEWER SEPARATION VILLAGE OF VILLA PARK

Method of Measurement and Basis of Payment. This work shall be measured and paid for at the contract unit price per lineal feet for STORM SEWERS, RUBBER GASKET, CLASS A (RCP), of the diameter specified.

PAY ITEM #59 – TREE PRUNING

Description. This work shall consist of performing tree pruning. This work shall be in accordance with Section 201 of the Standard Specifications and the current ANSI A300 (Part 1) – Pruning standard, except as modified herein.

All tree pruning shall be performed by a professional arborist.

Method of Measurement. This work will be measured for payment as each per tree.

Basis of Payment. This work will be paid for at the contract unit price per each for TREE PRUNING.

PAY ITEM #60 & 61 – WATER SERVICE CONNECTION

Description. This work shall consist of installing new copper water service connections and lines, complete in place from the water main to the existing water service line behind the curb stop, as shown on the plans or as directed by the Engineer. This work shall be in accordance with Section 562 of the Standard Specifications and with the Standard Specifications for Water and Sewer Construction in Illinois, except as modified herein.

Short service connections shall be defined as those services for properties which are located adjacent to the half of the right-of-way where the water main is located. Long service connections shall be defined as those services for properties which are located adjacent to the half of the right-of-way opposite where the water main is located.

Materials. Water service line pipe shall be Type “K” seamless copper water tubing conforming to ASTM B88, of the diameter specified. The pipe shall be marked with the manufacturer’s name or trademark and with markings indicating the type of the pipe.

Corporation stops shall be Mueller 300 Ball Corporation Valve Model B-25000 with AWWA taper (Mueller “CC”) thread inlet and copper flare straight connection outlet.

Curb stops shall be Mueller 300 Ball Curb Valve Model B-25154 with copper flare nuts on both ends, quarter turn check, and Minneapolis pattern thread top.

Curb boxes shall be Mueller extension type curb box Model H-10302 with Minneapolis pattern base, 1-½ in. inside diameter, and 2-½ in. base tapping diameter.

SECOND AVENUE SEWER SEPARATION VILLAGE OF VILLA PARK

Water service line couplings shall be Mueller H-15400 straight three-part unions with copper flare nuts on both ends, conforming to ANSI/AWWA C800, of the size needed.

All materials furnished as a part of this work shall comply with the latest requirements of the Federal Safe Drinking Water Act.

Construction. Where an existing water service is to be replaced, the contractor shall expose and remove the existing corporation stop. The contractor shall furnish a Smith-Blair circle repair sleeve of the appropriate diameter and of sufficient length and shall install it on the water main.

Contractor shall make a new connection to the water main using a tapping machine satisfactory to the Engineer. Contractor shall furnish and install a new corporation stop of the appropriate diameter on the water main. The Engineer may require that the Contractor furnish and install a tapping sleeve of the appropriate size if needed.

Contractor shall install a new water service line pipe from the corporation stop to the location of the existing curb box, or to such other location as shown in the plans or as directed by the Engineer. A single piece of copper water tubing of sufficient length to extend the full distance from the water main to the curb stop shall be utilized. Splicing of multiple sections of copper water tubing will not be permitted.

The new water service line and all components shall be installed a minimum of 5.5 ft. below finished grade. Where other utilities are encountered, the new water service line shall be located so that a minimum of 1 ft. of clearance exists in all directions between the new water service line and all other utilities. Where the new water service line crosses other utilities, if installation of the new water service line above the utility being crossed would result in any portion of the new water service line being less than 5.5 ft. below finished grade, the new water service line shall be installed below the utility being crossed.

The new water service line and all components shall be placed on a bedding of crushed aggregate of CA-7 or CA-11 gradation having a minimum thickness of 4 in. The bedding shall be placed to a minimum of 12 in. above the water service line.

Contractor shall furnish and install a new curb stop of the appropriate diameter. Contractor shall connect the new curb stop to the existing water service line behind the curb stop. If the existing water service line behind the curb stop is of a different material or diameter than the new water service line being installed, a section of new copper water service line shall be installed behind the curb stop. The existing water service line shall then be cut by an approved method, and the end of the existing water service line shall be joined to the new water service line with a water service line coupling of the appropriate type and size.

SECOND AVENUE SEWER SEPARATION VILLAGE OF VILLA PARK

Contractor shall furnish and install a new curb box. Contractor shall remove the existing curb box. Contractor shall install a piece of lathe or timber adjacent to the new curb box to identify its location until final restoration takes place. Contractor shall adjust the new curb box to finished grade immediately before the placement of sodding or seeding, or the completion of any other final restoration measures. Contractor shall then remove the lathe or timber.

In addition to all materials listed, Contractor shall also furnish and install all other necessary fittings, adapters, hardware, and materials necessary to complete the work as described.

Excavation, bedding, and backfilling of water service connections and lines will not be paid for separately, but shall be included in the cost of this work.

Method of Measurement. This work will be measured for payment as each water service connection and line installed, regardless of the length of the water service line, the depth of the water service line, conflicts with other utilities, or any other factors. No separate measurement will be made of pipe, fittings, couplings, stops, valves, or other components.

Basis of Payment. This work will be paid for at the contract unit price per each for WATER SERVICE CONNECTION (LONG), of the diameter specified, or WATER SERVICE CONNECTION (SHORT), of the diameter specified.

PAY ITEM #62 – WATER USAGE CREDIT

Description. Pay items are provided as a part of this contract for the purpose of documenting the quantity of water obtained from the Village by the Contractor.

If the Contractor elects to obtain water from the Village, the Contractor shall comply with the Special Provision USE OF FIRE HYDRANTS. The quantity of water obtained from the Village by the Contractor shall be deducted from the contract as WATER USAGE DEDUCTION, and shall be credited to the contract as WATER USAGE CREDIT.

The WATER USAGE CREDIT pay item for this contract has been established with a unit of measurement in thousands of gallons (TGAL), a quantity of one-hundred (100.00), and a contract unit price of eight dollars and eighty-five cents (\$8.85), for a total WATER USAGE CREDIT contract price of eight-hundred eighty-five dollars and no cents (\$885.00). Bidder, in submitting a bid, accepts the quantity, contract unit price, and total contract price of the WATER USAGE CREDIT pay item.

**SECOND AVENUE SEWER SEPARATION
VILLAGE OF VILLA PARK**

Method of Measurement. Water usage will be measured as the actual quantity of water obtained from the Village by the Contractor, which quantity shall be rounded up to the nearest 1,000 gallons.

Basis of Payment. The water usage credit will be paid for at the contract unit price per thousand gallons (TGAL) for WATER USAGE CREDIT. The quantity paid for as WATER USAGE CREDIT will be equal to the quantity deducted as WATER USAGE DEDUCTION.

PAY ITEM #63 – WATER USAGE DEDUCTION

Description. Pay items are provided as a part of this contract for the purpose of documenting the quantity of water obtained from the Village by the Contractor.

If the Contractor elects to obtain water from the Village, the Contractor shall comply with the Special Provision USE OF FIRE HYDRANTS. The quantity of water obtained from the Village by the Contractor shall be deducted from the contract as WATER USAGE DEDUCTION, and shall be credited to the contract as WATER USAGE CREDIT.

The WATER USAGE DEDUCTION pay item for this contract has been established with a unit of measurement in thousands of gallons (TGAL), a quantity of one-hundred (100.00), and a contract unit price of a deduction of eight dollars and eighty-five cents (\$8.85), for a total WATER USAGE DEDUCTION contract price of a deduction of eight-hundred eighty-five dollars and no cents (\$885.00). Bidder, in submitting a bid, accepts the quantity, contract unit price, and total contract price of the WATER USAGE DEDUCTION pay item.

Method of Measurement. Water usage will be measured as the actual quantity of water obtained from the Village by the Contractor, which quantity shall be rounded up to the nearest 1,000 gallons.

Basis of Payment. The water usage deduction will be deducted at the contract unit price per thousand gallons (TGAL) for WATER USAGE DEDUCTION. The quantity deducted as WATER USAGE DEDUCTION will be equal to the quantity paid for as WATER USAGE CREDIT.

**SECOND AVENUE SEWER SEPARATION
VILLAGE OF VILLA PARK**

ADJUSTMENTS AND RECONSTRUCTIONS

Effective: March 15, 2011

Revise the first paragraph of Article 602.04 to read:

“602.04 Concrete. Cast-in-place concrete for structures shall be constructed of Class SI concrete according to the applicable portions of Section 503. Cast-in-place concrete for pavement patching around adjustments and reconstructions shall be constructed of Class PP-1 concrete, unless otherwise noted in the plans, according to the applicable portions of Section 1020.”

Revise the third, fourth and fifth sentences of the second paragraph of Article 602.11(c) to read:

“Castings shall be set to the finished pavement elevation so that no subsequent adjustment will be necessary, and the space around the casting shall be filled with Class PP-1 concrete, unless otherwise noted in the plans, to the elevation of the surface of the base course or binder course. HMA surface or binder course material shall not be allowed. The pavement may be opened to traffic according to Article 701.17(e)(3)b.”

Revise Article 603.05 to read:

“603.05 Replacement of Existing Flexible Pavement. After the castings have been adjusted, the surrounding space shall be filled with Class PP-1 concrete, unless otherwise noted in the plans, to the elevation of the surface of the base course or binder course. HMA surface or binder course material shall not be allowed. The pavement may be opened to traffic according to Article 701.17(e)(3)b.”

Revise Article 603.06 to read:

“603.06 Replacement of Existing Rigid Pavement. After the castings have been adjusted, the pavement and HMA that was removed, shall be replaced with Class PP-1 concrete, unless otherwise noted in the plans, not less than 9 in. (225 mm) thick. The pavement may be opened to traffic according to Article 701.17(e)(3)b.

The surface of the Class PP concrete shall be constructed flush with the adjacent surface.”

Revise the first sentence of Article 603.07 to read:

“603.07 Protection Under Traffic. After the casting has been adjusted and the Class PP concrete has been placed, the work shall be protected by a barricade and two lights according to Article 701.17(e)(3)b.”

**SECOND AVENUE SEWER SEPARATION
VILLAGE OF VILLA PARK**

FRICTION AGGREGATE (D-1)

Effective: January 1, 2011

Revised: April 29, 2016

Revise Article 1004.03(a) of the Standard Specifications to read:

“1004.03 Coarse Aggregate for Hot-Mix Asphalt (HMA). The aggregate shall be according to Article 1004.01 and the following.

(a) Description. The coarse aggregate for HMA shall be according to the following table.

Use	Mixture	Aggregates Allowed
Class A	Seal or Cover	<u>Allowed Alone or in Combination</u> ^{5/} : Gravel Crushed Gravel Carbonate Crushed Stone Crystalline Crushed Stone Crushed Sandstone Crushed Slag (ACBF) Crushed Steel Slag Crushed Concrete
HMA Low ESAL	Stabilized Subbase Shoulders or	<u>Allowed Alone or in Combination</u> ^{5/} : Gravel Crushed Gravel Carbonate Crushed Stone Crystalline Crushed Stone Crushed Sandstone Crushed Slag (ACBF) Crushed Steel Slag ^{1/} Crushed Concrete
HMA High ESAL Low ESAL	Binder IL-19.0 or IL-19.0L SMA Binder	<u>Allowed Alone or in Combination</u> ^{5/ 6/} : Crushed Gravel Carbonate Crushed Stone ^{2/} Crystalline Crushed Stone Crushed Sandstone Crushed Slag (ACBF) Crushed Concrete ^{3/}

**SECOND AVENUE SEWER SEPARATION
VILLAGE OF VILLA PARK**

Use	Mixture	Aggregates Allowed							
HMA High ESAL Low ESAL	C Surface and Leveling Binder IL-9.5 or IL-9.5L	<u>Allowed Alone or in Combination</u> ^{5/} : Crushed Gravel Carbonate Crushed Stone ^{2/} Crystalline Crushed Stone Crushed Sandstone							
	SMA Ndesign 50 Surface	Crushed Slag (ACBF) Crushed Steel Slag ^{4/} Crushed Concrete ^{3/}							
HMA High ESAL	D Surface and Leveling Binder IL-9.5	<u>Allowed Alone or in Combination</u> ^{5/} : Crushed Gravel Carbonate Crushed Stone (other than Limestone) ^{2/} Crystalline Crushed Stone Crushed Sandstone Crushed Slag (ACBF) Crushed Steel Slag ^{4/} Crushed Concrete ^{3/}							
	SMA Ndesign 50 Surface	<u>Other Combinations Allowed:</u> <table border="1" style="width: 100%; border-collapse: collapse;"> <thead> <tr> <th style="text-align: left;"><i>Up to...</i></th> <th style="text-align: left;"><i>With...</i></th> </tr> </thead> <tbody> <tr> <td>25% Limestone</td> <td>Dolomite</td> </tr> <tr> <td>50% Limestone</td> <td>Any Mixture D aggregate other than Dolomite</td> </tr> <tr> <td>75% Limestone</td> <td>Crushed Slag (ACBF) or Crushed Sandstone</td> </tr> </tbody> </table>	<i>Up to...</i>	<i>With...</i>	25% Limestone	Dolomite	50% Limestone	Any Mixture D aggregate other than Dolomite	75% Limestone
<i>Up to...</i>	<i>With...</i>								
25% Limestone	Dolomite								
50% Limestone	Any Mixture D aggregate other than Dolomite								
75% Limestone	Crushed Slag (ACBF) or Crushed Sandstone								
HMA High ESAL	E Surface IL-9.5	<u>Allowed Alone or in Combination</u> ^{5/ 6/} : Crystalline Crushed Stone Crushed Sandstone Crushed Slag (ACBF) Crushed Steel Slag No Limestone.							
	SMA Ndesign 80 Surface	<u>Other Combinations Allowed:</u> <table border="1" style="width: 100%; border-collapse: collapse;"> <thead> <tr> <th style="text-align: left;"><i>Up to...</i></th> <th style="text-align: left;"><i>With...</i></th> </tr> </thead> <tbody> <tr> <td>50% Dolomite^{2/}</td> <td>Any Mixture E aggregate</td> </tr> </tbody> </table>	<i>Up to...</i>	<i>With...</i>	50% Dolomite ^{2/}	Any Mixture E aggregate			
<i>Up to...</i>	<i>With...</i>								
50% Dolomite ^{2/}	Any Mixture E aggregate								

**SECOND AVENUE SEWER SEPARATION
VILLAGE OF VILLA PARK**

Use	Mixture	Aggregates Allowed	
		75% Dolomite ^{2/}	Crushed Sandstone, Crushed Slag (ACBF), Crushed Steel Slag, or Crystalline Crushed Stone
		75% Crushed Gravel ^{2/} or Crushed Concrete ^{3/}	Crushed Sandstone, Crystalline Crushed Stone, Crushed Slag (ACBF), or Crushed Steel Slag
HMA High ESAL	F Surface IL-9.5	<u>Allowed Alone or in Combination</u> ^{5/ 6/} :	
	SMA Ndesign 80 Surface	Crystalline Crushed Stone Crushed Sandstone Crushed Slag (ACBF) Crushed Steel Slag No Limestone.	
	<u>Other Combinations Allowed:</u>		
		<i>Up to...</i>	<i>With...</i>
		50% Crushed Gravel ^{2/} , Crushed Concrete ^{3/} , or Dolomite ^{2/}	Crushed Sandstone, Crushed Slag (ACBF), Crushed Steel Slag, or Crystalline Crushed Stone

1/ Crushed steel slag allowed in shoulder surface only.

2/ Carbonate crushed stone (limestone) and/or crushed gravel shall not be used in SMA Ndesign 80. In SMA Ndesign 50, carbonate crushed stone shall not be blended with any of the other aggregates allowed alone in Ndesign 50 SMA binder or Ndesign 50 SMA surface.

3/ Crushed concrete will not be permitted in SMA mixes.

**SECOND AVENUE SEWER SEPARATION
VILLAGE OF VILLA PARK**

- 4/ Crushed steel slag shall not be used as leveling binder.
- 5/ When combinations of aggregates are used, the blend percent measurements shall be by volume.”
- 6/ Combining different types of aggregate will not be permitted in SMA Ndesign 80.”

GROUND TIRE RUBBER (GTR) MODIFIED ASPHALT BINDER (D-1)

Effective: June 26, 2006

Revised: April 1, 2016

Add the following to the end of article 1032.05 of the Standard Specifications:

“(c) Ground Tire Rubber (GTR) Modified Asphalt Binder. A quantity of 10.0 to 14.0 percent GTR (Note 1) shall be blended by dry unit weight with a PG 64-28 to make a GTR 70-28 or a PG 58-28 to make a GTR 64-28. The base PG 64-28 and PG 58-28 asphalt binders shall meet the requirements of Article 1032.05(a). Compatible polymers may be added during production. The GTR modified asphalt binder shall meet the requirements of the following table.

Test	Asphalt Grade 70-28	Asphalt Grade GTR 64-28
Flash Point (C.O.C.), AASHTO T 48, °F (°C), min.	450 (232)	450 (232)
Rotational Viscosity, AASHTO T 316 @ 275 °F (135 °C), Poises, Pa·s, max.	30 (3)	30 (3)
Softening Point, AASHTO T 53, °F (°C), min.	135 (57)	130 (54)
Elastic Recovery, ASTM D 6084, Procedure A (sieve waived) @ 77 °F, (25 °C), aged, ss, 100 mm elongation, 5 cm/min., cut immediately, %, min.	65	65

Note 1. GTR shall be produced from processing automobile and/or light truck tires by the ambient grinding method. GTR shall not exceed 1/16 in. (2 mm) in any dimension and shall contain no free metal particles or other materials. A mineral powder (such as talc) meeting the requirements of AASHTO M 17 may be added, up to a maximum of four percent by weight of GTR to reduce sticking and caking of the GTR particles.

**SECOND AVENUE SEWER SEPARATION
VILLAGE OF VILLA PARK**

When tested in accordance with Illinois modified AASHTO T 27, a 50 g sample of the GTR shall conform to the following gradation requirements:

Sieve Size	Percent Passing
No. 16 (1.18 mm)	100
No. 30 (600 μm)	95 ± 5
No. 50 (300 μm)	> 20

Add the following to the end of Note 1. of article 1030.03 of the Standard Specifications:

“A dedicated storage tank for the Ground Tire Rubber (GTR) modified asphalt binder shall be provided. This tank must be capable of providing continuous mechanical mixing throughout by continuous agitation and recirculation of the asphalt binder to provide a uniform mixture. The tank shall be heated and capable of maintaining the temperature of the asphalt binder at 300 °F to 350 °F (149 °C to 177 °C). The asphalt binder metering systems of dryer drum plants shall be calibrated with the actual GTR modified asphalt binder material with an accuracy of ± 0.40 percent.”

Revise 1030.02(c) of the Standard Specifications to read:

“(c) RAP Materials (Note 5)1031”

Add the following note to 1030.02 of the Standard Specifications:

Note 5. When using reclaimed asphalt pavement and/or reclaimed asphalt shingles, the maximum asphalt binder replacement percentage shall be according to the most recent special provision for recycled materials.

HMA MIXTURE DESIGN REQUIREMENTS (D-1)

Effective: January 1, 2013

Revised: April 1, 2016

1) Design Composition and Volumetric Requirements

Revise the table in Article 406.06(d) of the Standard Specifications to read:

**SECOND AVENUE SEWER SEPARATION
VILLAGE OF VILLA PARK**

"MINIMUM COMPACTED LIFT THICKNESS	
Mixture Composition	Thickness, in. (mm)
IL-4.75	3/4 (19)
SMA-9.5, IL-9.5, IL-9.5L	1 1/2 (38)
SMA-12.5	2 (50)
IL-19.0, IL-19.0L	2 1/4 (57)"

Revise the table in Article 1004.03(c) of the Standard Specifications to read:

"Use	Size/Application	Gradation No.
Class A-1, 2, & 3	3/8 in. (10 mm) Seal	CA 16
Class A-1	1/2 in. (13 mm) Seal	CA 15
Class A-2 & 3	Cover	CA 14
HMA High ESAL	IL-19.0 IL-9.5	CA 11 ^{1/} CA 16, CA 13 ^{3/}
HMA Low ESAL	IL-19.0L IL-9.5L Stabilized Subbase or Shoulders	CA 11 ^{1/} CA 16
SMA ^{2/}	1/2 in. (12.5mm) Binder & Surface IL 9.5 Surface	CA13 ^{3/} , CA14 or CA16 CA16, CA 13 ^{3/}

1/ CA 16 or CA 13 may be blended with the gradations listed.

2/ The coarse aggregates used shall be capable of being combined with stone sand, slag sand, or steel slag sand meeting the FA/FM 20 gradation and mineral filler to meet the approved mix design and the mix requirements noted herein.

3/ CA 13 shall be 100 percent passing the 1/2 in. (12.5mm) sieve.

Revise Article 1004.03(e) of the Supplemental Specifications to read:

"(e) Absorption. For SMA the coarse aggregate shall also have water absorption

≤ 2.0 percent."

**SECOND AVENUE SEWER SEPARATION
VILLAGE OF VILLA PARK**

Revise the last paragraph of Article 1102.01 (a) (5) of the Standard Specifications to read:

“IL-4.75 and Stone Matrix Asphalt (SMA) mixtures which contain aggregate having absorptions greater than or equal to 2.0 percent, or which contain steel slag sand, shall have minimum surge bin storage plus haul time of 1.5 hours.”

Revise the nomenclature table in Article 1030.01 of the Standard Specifications to read:

“High ESAL	IL-19.0 binder; IL-9.5 surface; IL-4.75; SMA-12.5, SMA-9.5
Low ESAL	IL-19.0L binder; IL-9.5L surface; Stabilized Subbase (HMA) ^{1/} ; HMA Shoulders ^{2/}

1/ Uses 19.0L binder mix.

2/ Uses 19.0L for lower lifts and 9.5L for surface lift.”

Revise Article 1030.02 of the Standard Specifications and Supplemental Specifications to read:

“**1030.02 Materials.** Materials shall be according to the following.

Item	Article/Section
(a)	Coarse Aggregate 1004.03
(b)	Fine Aggregate 1003.03
(c)	RAP Material 1031
(d)	Mineral Filler 1011
(e)	Hydrated Lime 1012.01
(f)	Slaked Quicklime (Note 1)
(g)	Performance Graded Asphalt Binder (Note 2) 1032
(h)	Fibers (Note 3)

**SECOND AVENUE SEWER SEPARATION
VILLAGE OF VILLA PARK**

(i) Warm Mix Asphalt (WMA) Technologies (Note 4)

Note 1. Slaked quicklime shall be according to ASTM C 5.

Note 2. The asphalt binder shall be an SBS PG 76-28 when the SMA is used on a full-depth asphalt pavement and SBS PG 76-22 when used as an overlay, except where modified herein. The asphalt binder shall be an Elvaloy or SBS PG 76-22 for IL-4.75, except where modified herein. The elastic recovery shall be a minimum of 80.

Note 3. A stabilizing additive such as cellulose or mineral fiber shall be added to the SMA mixture according to Illinois Modified AASHTO M 325. The stabilizing additive shall meet the Fiber Quality Requirements listed in Illinois Modified AASHTO M 325. Prior to approval and use of fibers, the Contractor shall submit a notarized certification by the producer of these materials stating they meet these requirements. Reclaimed Asphalt Shingles (RAS) may be used in Stone Matrix Asphalt (SMA) mixtures designed with an SBA polymer modifier as a fiber additive if the mix design with RAS included meets AASHTO T305 requirements. The RAS shall be from a certified source that produces either Type I or Type 2. Material shall meet requirements noted herein and the actual dosage rate will be determined by the Engineer.

Note 4. Warm mix additives or foaming processes shall be selected from the current Bureau of Materials and Physical Research Approved List, "Warm Mix Asphalt Technologies".

Revise Article 1030.04(a)(1) of the Standard Specifications and the Supplemental Specifications to read:

" (1) High ESAL Mixtures. The Job Mix Formula (JMF) shall fall within the following limits.

High ESAL, MIXTURE COMPOSITION (% PASSING) ^{1/}										
Sieve Size	IL-19.0 mm		SMA ^{4/} IL-12.5 mm		SMA ^{4/} IL-9.5 mm		IL-9.5 mm		IL-4.75 mm	
	min	max	min	max	min	max	min	max	min	max
1 1/2 in. (37.5 mm)										
1 in. (25 mm)		100								
3/4 in. (19 mm)	90	100		100						
1/2 in. (12.5 mm)	75	89	80	100		100		100		100
3/8 in. (9.5 mm)				65	90	100	90	100		100
#4 (4.75 mm)	40	60	20	30	36	50	34	69	90	100
#8 (2.36 mm)	20	42	16	24 ^{5/}	16	32 ^{5/}	34 ^{6/}	52 ^{2/}	70	90

**SECOND AVENUE SEWER SEPARATION
VILLAGE OF VILLA PARK**

#16 (1.18 mm)	15	30					10	32	50	65
#30 (600 µm)			12	16	12	18				
#50 (300 µm)	6	15					4	15	15	30
#100 (150 µm)	4	9					3	10	10	18
#200 (75 µm)	3	6	7.0	9.0 ^{3/}	7.5	9.5 ^{3/}	4	6	7	9 ^{3/}
Ratio Dust/Asphalt Binder		1.0		1.5		1.5		1.0		1.0

- 1/ Based on percent of total aggregate weight.
- 2/ The mixture composition shall not exceed 44 percent passing the #8 (2.36 mm) sieve for surface courses with Ndesign = 90.
- 3/ Additional minus No. 200 (0.075 mm) material required by the mix design shall be mineral filler, unless otherwise approved by the Engineer.
- 4/ The maximum percent passing the #635 (20 µm) sieve shall be ≤ 3 percent.
- 5/ When establishing the Adjusted Job Mix Formula (AJMF) the percent passing the #8 (2.36 mm) sieve shall not be adjusted above the percentage stated on the table.
- 6/ When establishing the Adjusted Job Mix Formula (AJMF) the percent passing the #8 (2.36 mm) sieve shall not be adjusted below 34 percent.

Revise Article 1030.04(b)(1) of the Standard Specifications to read:

“(1) High ESAL Mixtures. The target value for the air voids of the HMA shall be 4.0 percent and for IL-4.75 it shall be 3.5 percent at the design number of gyrations. The VMA and VFA of the HMA design shall be based on the nominal maximum size of the aggregate in the mix, and shall conform to the following requirements.

VOLUMETRIC REQUIREMENTS High ESAL
--

**SECOND AVENUE SEWER SEPARATION
VILLAGE OF VILLA PARK**

	Voids in the Mineral Aggregate (VMA), % minimum			Voids Filled with Asphalt Binder (VFA), %
Ndesign	IL-19.0	IL-9.5	IL-4.75 ^{1/}	
50	13.5	15.0	18.5	65 – 78 ^{2/}
70				65 - 75
90				

1/ Maximum Draindown for IL-4.75 shall be 0.3 percent

2/ VFA for IL-4.75 shall be 72-85 percent”

Replace Article 1030.04(b)(3) of the Standard Specifications with the following:

“(3) SMA Mixtures.

Volumetric Requirements SMA ^{1/}			
Ndesign	Design Air Voids Target %	Voids in the Mineral Aggregate (VMA), % min.	Voids Filled with Asphalt (VFA), %
80 ^{4/}	3.5	17.0 ^{2/}	75 - 83
		16.0 ^{3/}	

1/ Maximum draindown shall be 0.3 percent. The draindown shall be determined at the JMF asphalt binder content at the mixing temperature plus 30 °F.

2/ Applies when specific gravity of coarse aggregate is ≥ 2.760.

3/ Applies when specific gravity of coarse aggregate is < 2.760.

4/ Blending of different types of aggregate will not be permitted.

For surface course, the coarse aggregate can be crushed steel slag, crystalline crushed stone or crushed sandstone. For binder course, coarse aggregate shall be crushed stone (dolomite), crushed gravel, crystalline crushed stone, or crushed sandstone.

**SECOND AVENUE SEWER SEPARATION
VILLAGE OF VILLA PARK**

Add to the end of Article 1030.05 (d) (2) a. of the Standard Specifications:

“During production, the Contractor shall test SMA mixtures for draindown according to AASHTO T305 at a frequency of 1 per day of production.”

Delete last sentence of the second paragraph of Article 1102.01(a) (4) b. 2.

Add to the end of Article 1102.01 (a) (4) b. 2.:

“As an option, collected dust (baghouse) may be used in lieu of manufactured mineral filler according to the following:

- (a.) Sufficient collected dust (baghouse) is available for production of the SMA mix for the entire project.
- (b.) A mix design was prepared based on collected dust (baghouse).

2) Design Verification and Production

Revise Article 1030.04 (d) of the Standard Specifications to read:

“(d) Verification Testing. High ESAL, IL-4.75, and SMA mix designs submitted for verification will be tested to ensure that the resulting mix designs will pass the required criteria for the Hamburg Wheel Test (IL mod AASHTO T-324) and the Tensile Strength Test (IL mod AASHTO T-283). The Department will perform a verification test on gyratory specimens compacted by the Contractor. If the mix fails the Department’s verification test, the Contractor shall make the necessary changes to the mix and resubmit compacted specimens to the Department for verification. If the mix fails again, the mix design will be rejected.

All new and renewal mix designs will be required to be tested, prior to submittal for Department verification and shall meet the following requirements:

- (1) Hamburg Wheel Test criteria. The maximum allowable rut depth shall be 0.5 in. (12.5 mm). The minimum number of wheel passes at the 0.5 in. (12.5 mm) rut depth criteria shall be based on the high temperature binder grade of the mix as specified in the mix requirements table of the plans.

Illinois Modified AASHTO T 324 Requirements ^{1/}

Asphalt Binder Grade	# Repetitions	Max Rut Depth (mm)
PG 70 -XX (or	20,000	12.5

**SECOND AVENUE SEWER SEPARATION
VILLAGE OF VILLA PARK**

higher)		
PG 64 -XX (or lower)	10,000	12.5

- 1/ When produced at temperatures of 275 ± 5 °F (135 ± 3 °C) or less, loose Warm Mix Asphalt shall be oven aged at 270 ± 5 °F (132 ± 3 °C) for two hours prior to gyratory compaction of Hamburg Wheel specimens.

Note: For SMA Designs (N-80) the maximum rut depth is 6.0 mm at 20,000 repetitions.

For IL 4.75mm Designs (N-50) the maximum rut depth is 9.0mm at 15,000 repetitions.

(2) Tensile Strength Criteria. The minimum allowable conditioned tensile strength shall be 60 psi (415 kPa) for non-polymer modified performance graded (PG) asphalt binder and 80 psi (550 kPa) for polymer modified PG asphalt binder. The maximum allowable unconditioned tensile strength shall be 200 psi (1380 kPa)."

Production Testing. Revise first paragraph of Article 1030.06(a) of the Standard Specifications to read:

"(a) High ESAL, IL-4.75, WMA, and SMA Mixtures. For each contract, a 300 ton (275 metric tons) test strip, except for SMA mixtures it will be 400 ton (363 metric ton), will be required at the beginning of HMA production for each mixture with a quantity of 3000 tons (2750 metric tons) or more according to the Manual of Test Procedures for Materials "Hot Mix Asphalt Test Strip Procedures".

Add the following after the sixth paragraph in Article 1030.06 (a) of the Standard Specifications:

"The Hamburg Wheel test shall also be conducted on all HMA mixtures from a sample taken within the first 500 tons (450 metric tons) on the first day of production or during start up with a split reserved for the Department. The mix sample shall be tested according to the Illinois Modified AASHTO T 324 and shall meet the requirements specified herein. Mix production shall not exceed 1500 tons (1350 metric tons) or one day's production, whichever comes first, until the testing is completed and the mixture is found to be in conformance. The requirement to cease mix production may be waived if the plant produced mixture demonstrates conformance prior to start of mix production for a contract.

If the mixture fails to meet the Hamburg Wheel criteria, no further mixture will be accepted until the Contractor takes such action as is necessary to furnish a mixture meeting the criteria"

Method of Measurement:

**SECOND AVENUE SEWER SEPARATION
VILLAGE OF VILLA PARK**

Add the following after the fourth paragraph of Article 406.13 (b):

“The plan quantities of SMA mixtures shall be adjusted using the actual approved binder and surface Mix Design’s G_{mb}.”

Basis of Payment.

Replace the fourth paragraph of Article 406.14 of the Standard Specifications with the following:

“Stone matrix asphalt will be paid for at the contract unit price per ton (metric ton) for POLYMERIZED HOT-MIX ASPHALT SURFACE COURSE, STONE MATRIX ASPHALT, of the mixture composition and Ndesign specified; and POLYMERIZED HOT-MIX ASPHALT BINDER COURSE, STONE MATRIX ASPHALT, of the mixture composition and Ndesign specified.”

RECLAIMED ASPHALT PAVEMENT AND RECLAIMED ASPHALT SHINGLES (D-1)

Effective: November 1, 2012

Revise: January 1, 2018

Revise Section 1031 of the Standard Specifications to read:

“SECTION 1031. RECLAIMED ASPHALT PAVEMENT AND RECLAIMED ASPHALT SHINGLES

1031.01 Description. Reclaimed asphalt pavement and reclaimed asphalt shingles shall be according to the following.

- (a) Reclaimed Asphalt Pavement (RAP). RAP is the material resulting from cold milling or crushing an existing hot-mix asphalt (HMA) pavement. RAP will be considered processed FRAP after completion of both crushing and screening to size. The Contractor shall supply written documentation that the RAP originated from routes or airfields under federal, state, or local agency jurisdiction.
- (b) Reclaimed Asphalt Shingles (RAS). Reclaimed asphalt shingles (RAS). RAS is from the processing and grinding of preconsumer or post-consumer shingles. RAS shall be a clean and uniform material with a maximum of 0.5 percent unacceptable material, as defined in Central Bureau of Materials Policy Memorandum, “Reclaimed Asphalt Shingle (RAS) Sources”, by weight of RAS. All RAS used shall come from a Central Bureau of Materials approved processing facility where it shall be ground and processed to 100 percent passing the 3/8 in. (9.5 mm) sieve and 90 percent passing the #4 (4.75 mm)

**SECOND AVENUE SEWER SEPARATION
VILLAGE OF VILLA PARK**

sieve. RAS shall meet the testing requirements specified herein. In addition, RAS shall meet the following Type 1 or Type 2 requirements.

- (1) Type 1. Type 1 RAS shall be processed, preconsumer asphalt shingles salvaged from the manufacture of residential asphalt roofing shingles.
- (2) Type 2. Type 2 RAS shall be processed post-consumer shingles only, salvaged from residential, or four unit or less dwellings not subject to the National Emission Standards for Hazardous Air Pollutants (NESHAP).

1031.02 Stockpiles. RAP and RAS stockpiles shall be according to the following.

(a) RAP Stockpiles. The Contractor shall construct individual, sealed RAP stockpiles meeting one of the following definitions. Additional processed RAP (FRAP) shall be stockpiled in a separate working pile, as designated in the QC Plan, and only added to the sealed stockpile when test results for the working pile are complete and are found to meet tolerances specified herein for the original sealed FRAP stockpile. Stockpiles shall be sufficiently separated to prevent intermingling at the base. All stockpiles (including unprocessed RAP and FRAP) shall be identified by signs indicating the type as listed below (i.e. "Non-Quality, FRAP -#4 or Type 2 RAS", etc...).

- (1) Fractionated RAP (FRAP). FRAP shall consist of RAP from Class I, HMA (High and Low ESAL) or equivalent mixtures. The coarse aggregate in FRAP shall be crushed aggregate and may represent more than one aggregate type and/or quality, but shall be at least C quality. All FRAP shall be processed prior to testing and sized into fractions with the separation occurring on or between the #4 (4.75 mm) and 1/2 in. (12.5 mm) sieves. Agglomerations shall be minimized such that 100 percent of the RAP in the coarse fraction shall pass the maximum sieve size specified for the mix the FRAP will be used in.
- (2) Restricted FRAP (B quality) stockpiles shall consist of RAP from Class I, HMA (High ESAL), or HMA (High ESAL). If approved by the Engineer, the aggregate from a maximum 3.0 in. (75 mm) single combined pass of surface/binder milling will be classified as B quality. All millings from this application will be processed into FRAP as described previously.
- (3) Conglomerate. Conglomerate RAP stockpiles shall consist of RAP from Class I, HMA (High and Low ESAL) or equivalent mixtures. The coarse aggregate in this RAP shall be crushed aggregate and may represent more than one aggregate type and/or quality, but shall be at least C quality. This RAP may have an inconsistent gradation and/or asphalt binder content prior to processing. All conglomerate RAP shall be processed (FRAP) prior to

SECOND AVENUE SEWER SEPARATION VILLAGE OF VILLA PARK

testing. Conglomerate RAP stockpiles shall not contain steel slag or other expansive material as determined by the Department.

- (4) Conglomerate “D” Quality (DQ). Conglomerate DQ RAP stockpiles shall consist of RAP from HMA shoulders, bituminous stabilized subbases or HMA (Low ESAL)/HMA (Low ESAL) IL-19.0L binder mixture. The coarse aggregate in this RAP may be crushed or round but shall be at least D quality. This RAP may have an inconsistent gradation and/or asphalt binder content. Conglomerate DQ RAP stockpiles shall not contain steel slag or other expansive material as determined by the Department.
- (5) Non-Quality. RAP stockpiles that do not meet the requirements of the stockpile categories listed above shall be classified as “Non-Quality”.

RAP or FRAP containing contaminants, such as earth, brick, sand, concrete, sheet asphalt, bituminous surface treatment (i.e. chip seal), pavement fabric, joint sealants, plant cleanout etc., will be unacceptable unless the contaminants are removed to the satisfaction of the Engineer. Sheet asphalt shall be stockpiled separately.

- (b) RAS Stockpiles. Type 1 and Type 2 RAS shall be stockpiled separately and shall be sufficiently separated to prevent intermingling at the base. Each stockpile shall be signed indicating what type of RAS is present.

However, a RAS source may submit a written request to the Department for approval to blend mechanically a specified ratio of Type 1 RAS with Type 2 RAS. The source will not be permitted to change the ratio of the blend without the Department prior written approval. The Engineer’s written approval will be required, to mechanically blend RAS with any fine aggregate produced under the AGCS, up to an equal weight of RAS, to improve workability. The fine aggregate shall be “B Quality” or better from an approved Aggregate Gradation Control System source. The fine aggregate shall be one that is approved for use in the HMA mixture and accounted for in the mix design and during HMA production.

Records identifying the shingle processing facility supplying the RAS, RAS type, and lot number shall be maintained by project contract number and kept for a minimum of three years.

1031.03 Testing. FRAP and RAS testing shall be according to the following.

- (a) FRAP Testing. When used in HMA, the FRAP shall be sampled and tested either during processing or after stockpiling. It shall also be sampled during HMA production.

**SECOND AVENUE SEWER SEPARATION
VILLAGE OF VILLA PARK**

- (1) During Stockpiling. For testing during stockpiling, washed extraction samples shall be run at the minimum frequency of one sample per 500 tons (450 metric tons) for the first 2000 tons (1800 metric tons) and one sample per 2000 tons (1800 metric tons) thereafter. A minimum of five tests shall be required for stockpiles less than 4000 tons (3600 metric tons).
- (2) Incoming Material. For testing as incoming material, washed extraction samples shall be run at a minimum frequency of one sample per 2000 tons (1800 metric tons) or once per week, whichever comes first.
- (3) After Stockpiling. For testing after stockpiling, the Contractor shall submit a plan for approval to the District proposing a satisfactory method of sampling and testing the RAP/FRAP pile either in-situ or by restockpiling. The sampling plan shall meet the minimum frequency required above and detail the procedure used to obtain representative samples throughout the pile for testing.

Before extraction, each field sample of FRAP, shall be split to obtain two samples of test sample size. One of the two test samples from the final split shall be labeled and stored for Department use. The Contractor shall extract the other test sample according to Department procedure. The Engineer reserves the right to test any sample (split or Department-taken) to verify Contractor test results.

- (b) RAS Testing. RAS shall be sampled and tested during stockpiling according to Central Bureau of Materials Policy Memorandum, "Reclaimed Asphalt Shingle (RAS) Sources". The Contractor shall also sample as incoming material at the HMA plant.
 - (1) During Stockpiling. Washed extraction and testing for unacceptable materials shall be run at the minimum frequency of one sample per 200 tons (180 metric tons) for the first 1000 tons (900 metric tons) and one sample per 1000 tons (900 metric tons) thereafter. A minimum of five samples are required for stockpiles less than 1000 tons (900 metric tons). Once a ≤ 1000 ton (900 metric ton), five-sample/test stockpile has been established it shall be sealed. Additional incoming RAS shall be in a separate working pile as designated in the Quality Control plan and only added to the sealed stockpile when the test results of the working pile are complete and are found to meet the tolerances specified herein for the original sealed RAS stockpile.
 - (2) Incoming Material. For testing as incoming material at the HMA plant, washed extraction shall be run at the minimum frequency of one sample per 250 tons (227 metric tons). A minimum of five samples are required for stockpiles less than 1000 tons (900 metric tons). The incoming material test results shall meet the tolerances specified herein.

**SECOND AVENUE SEWER SEPARATION
VILLAGE OF VILLA PARK**

The Contractor shall obtain and make available all test results from start of the initial stockpile sampled and tested at the shingle processing facility in accordance with the facility's QC Plan.

Before extraction, each field sample shall be split to obtain two samples of test sample size. One of the two test samples from the final split shall be labeled and stored for Department use. The Contractor shall extract the other test sample according to Department procedures. The Engineer reserves the right to test any sample (split or Department-taken) to verify Contractor test results.

1031.04 Evaluation of Tests. Evaluation of test results shall be according to the following.

- (a) Evaluation of FRAP Test Results. All test results shall be compiled to include asphalt binder content, gradation and, when applicable (for slag), G_{mm} . A five test average of results from the original pile will be used in the mix designs. Individual extraction test results run thereafter, shall be compared to the average used for the mix design, and will be accepted if within the tolerances listed below.

Parameter	FRAP
No. 4 (4.75 mm)	± 6 %
No. 8 (2.36 mm)	± 5 %
No. 30 (600 μ m)	± 5 %
No. 200 (75 μ m)	± 2.0 %
Asphalt Binder	± 0.3 %
G_{mm}	± 0.03 ^{1/}

- 1/ For stockpile with slag or steel slag present as determined in the current Manual of Test Procedures Appendix B 21, "Determination of Reclaimed Asphalt Pavement Aggregate Bulk Specific Gravity".

If any individual sieve and/or asphalt binder content tests are out of the above tolerances when compared to the average used for the mix design, the FRAP stockpile shall not be used in Hot-Mix Asphalt unless the FRAP representing those tests is removed from the stockpile. All test data and acceptance ranges shall be sent to the District for evaluation.

The Contractor shall maintain a representative moving average of five tests to be used for Hot-Mix Asphalt production.

With the approval of the Engineer, the ignition oven may be substituted for extractions according to the ITP, "Calibration of the Ignition Oven for the Purpose of Characterizing Reclaimed Asphalt Pavement (RAP)" or Illinois Modified AASHTO T-164-11, Test Method A.

**SECOND AVENUE SEWER SEPARATION
VILLAGE OF VILLA PARK**

(b) Evaluation of RAS Test Results. All of the test results, with the exception of percent unacceptable materials, shall be compiled and averaged for asphalt binder content and gradation. A five test average of results from the original pile will be used in the mix designs. Individual test results run thereafter, when compared to the average used for the mix design, will be accepted if within the tolerances listed below.

Parameter	RAS
No. 8 (2.36 mm)	± 5 %
No. 16 (1.18 mm)	± 5 %
No. 30 (600 µm)	± 4 %
No. 200 (75 µm)	± 2.5 %
Asphalt Binder Content	± 2.0 %

If any individual sieve and/or asphalt binder content tests are out of the above tolerances when compared to the average used for the mix design, the RAS shall not be used in Hot-Mix Asphalt unless the RAS representing those tests is removed from the stockpile. All test data and acceptance ranges shall be sent to the District for evaluation.

(c) Quality Assurance by the Engineer. The Engineer may witness the sampling and splitting conduct assurance tests on split samples taken by the Contractor for quality control testing a minimum of once a month.

The overall testing frequency will be performed over the entire range of Contractor samples for asphalt binder content and gradation. The Engineer may select any or all split samples for assurance testing. The test results will be made available to the Contractor as soon as they become available.

The Engineer will notify the Contractor of observed deficiencies.

Differences between the Contractor's and the Engineer's split sample test results will be considered acceptable if within the following limits.

Test Parameter	Acceptable Limits of Precision	
	FRAP	RAS
% Passing: ^{1/}		
1/2 in.	5.0%	
No. 4	5.0%	
No. 8	3.0%	4.0%
No. 30	2.0%	4.0%
No. 200	2.2%	4.0%
Asphalt Binder Content	0.3%	3.0%

**SECOND AVENUE SEWER SEPARATION
VILLAGE OF VILLA PARK**

G_{mm}	0.030	
----------	-------	--

1/ Based on washed extraction.

In the event comparisons are outside the above acceptable limits of precision, the Engineer will immediately investigate.

- (d) Acceptance by the Engineer. Acceptable of the material will be based on the validation of the Contractor's quality control by the assurance process.

1031.05 Quality Designation of Aggregate in RAP and FRAP.

- (a) RAP. The aggregate quality of the RAP for homogeneous, conglomerate, and conglomerate "D" quality stockpiles shall be set by the lowest quality of coarse aggregate in the RAP stockpile and are designated as follows.

(1) RAP from Class I, HMA (High ESAL), or (Low ESAL) IL-9.5L surface mixtures are designated as containing Class B quality coarse aggregate.

(2) RAP from HMA (Low ESAL) IL-19.0L binder mixture is designated as Class D quality coarse aggregate.

(3) RAP from Class I, HMA (High ESAL) binder mixtures, bituminous base course mixtures, and bituminous base course widening mixtures are designated as containing Class C quality coarse aggregate.

(4) RAP from bituminous stabilized subbase and BAM shoulders are designated as containing Class D quality coarse aggregate.

- (b) FRAP. If the Engineer has documentation of the quality of the FRAP aggregate, the Contractor shall use the assigned quality provided by the Engineer.

If the quality is not known, the quality shall be determined as follows. Fractionated RAP stockpiles containing plus #4 (4.75 mm) sieve coarse aggregate shall have a maximum tonnage of 5,000 tons (4,500 metric tons). The Contractor shall obtain a representative sample witnessed by the Engineer. The sample shall be a minimum of 50 lb (25 kg). The sample shall be extracted according to Illinois Modified AASHTO T 164 by a consultant laboratory prequalified by the Department for the specified testing. The consultant laboratory shall submit the test results along with the recovered aggregate to the District Office. The cost for this testing shall be paid by the Contractor. The District will forward the sample to the Central Bureau of Materials Aggregate Lab for MicroDeval Testing, according to ITP 327. A maximum loss of 15.0 percent will be applied for all HMA applications. The fine aggregate portion of the fractionated RAP shall not be used in any HMA mixtures that require a minimum

**SECOND AVENUE SEWER SEPARATION
VILLAGE OF VILLA PARK**

of "B" quality aggregate or better, until the coarse aggregate fraction has been determined to be acceptable thru a MicroDeval Testing.

1031.06 Use of FRAP and/or RAS in HMA. The use of FRAP and/or RAS shall be the Contractor's option when constructing HMA in all contracts.

(a) FRAP. The use of FRAP in HMA shall be as follows.

- (1) Coarse Aggregate Size (after extraction). The coarse aggregate in all FRAP shall be equal to or less than the nominal maximum size requirement for the HMA mixture to be produced.
- (2) Steel Slag Stockpiles. FRAP stockpiles containing steel slag or other expansive material, as determined by the Department, shall be homogeneous and will be approved for use in HMA (High ESAL and Low ESAL) mixtures regardless of lift or mix type.
- (3) Use in HMA Surface Mixtures (High and Low ESAL). FRAP stockpiles for use in HMA surface mixtures (High and Low ESAL) shall have coarse aggregate that is Class B quality or better. FRAP shall be considered equivalent to limestone for frictional considerations unless produced/screened to minus 3/8 inch.
- (4) Use in HMA Binder Mixtures (High and Low ESAL), HMA Base Course, and HMA Base Course Widening. FRAP stockpiles for use in HMA binder mixtures (High and Low ESAL), HMA base course, and HMA base course widening shall be FRAP in which the coarse aggregate is Class C quality or better.
- (5) Use in Shoulders and Subbase. FRAP stockpiles for use in HMA shoulders and stabilized subbase (HMA) shall be FRAP, Restricted FRAP, conglomerate, or conglomerate DQ.

(b) RAS. RAS meeting Type 1 or Type 2 requirements will be permitted in all HMA applications as specified herein.

(c) FRAP and/or RAS Usage Limits. Type 1 or Type 2 RAS may be used alone or in conjunction with FRAP in HMA mixtures up to a maximum of 5.0 percent by weight of the total mix.

When FRAP is used alone or FRAP is used in conjunction with RAS, the percent of virgin asphalt binder replacement (ABR) shall not exceed the amounts indicated in the table below for a given N Design.

Max Asphalt Binder Replacement for FRAP with RAS Combination

**SECOND AVENUE SEWER SEPARATION
VILLAGE OF VILLA PARK**

HMA Mixtures ^{1/2/} _{4/}	Maximum % ABR		
	Binder/Leveling Binder	Surface	Polymer Modified ^{3/}
30L	50	40	30
50	40	35	30
70	40	30	30
90	40	30	30
4.75 mm N-50			40
SMA N-80			30

- 1/ For Low ESAL HMA shoulder and stabilized subbase, the percent asphalt binder replacement shall not exceed 50 % of the total asphalt binder in the mixture.
- 2/ When the binder replacement exceeds 15 % for all mixes, except for SMA and IL-4.75, the high and low virgin asphalt binder grades shall each be reduced by one grade (i.e. 25 % binder replacement using a virgin asphalt binder grade of PG64-22 will be reduced to a PG58-28). When constructing full depth HMA and the ABR is less than 15 %, the required virgin asphalt binder grade shall be PG64-28.
- 3/ When the ABR for SMA or IL-4.75 is 15 % or less, the required virgin asphalt binder shall be SBS PG76-22 and the elastic recovery shall be a minimum of 80. When the ABR for SMA or IL-4.75 exceeds 15%, the virgin asphalt binder grade shall be SBS PG70-28 and the elastic recovery shall be a minimum of 80.
- 4/ When FRAP or RAS is used alone, the maximum percent asphalt binder replacement designated on the table shall be reduced by 10 %.

1031.07 HMA Mix Designs. At the Contractor's option, HMA mixtures may be constructed utilizing RAP/FRAP and/or RAS material meeting the detailed requirements specified herein.

- (a) FRAP and/or RAS. FRAP and /or RAS mix designs shall be submitted for verification. If additional FRAP or RAS stockpiles are tested and found to be within tolerance, as defined under "Evaluation of Tests" herein, and meet all requirements herein, the additional FRAP or RAS stockpiles may be used in the original design at the percent previously verified.

**SECOND AVENUE SEWER SEPARATION
VILLAGE OF VILLA PARK**

(b) RAS. Type 1 and Type 2 RAS are not interchangeable in a mix design.

The RAP, FRAP and RAS stone specific gravities (G_{sb}) shall be according to the “Determination of Aggregate Bulk (Dry) Specific Gravity (G_{sb}) or Reclaimed Asphalt Pavement (RAP) and Reclaimed Asphalt Shingles (RAS)” procedure in the Department’s Manual of Test Procedures for Materials.

1031.08 HMA Production. HMA production utilizing FRAP and/or RAS shall be as follows.

To remove or reduce agglomerated material, a scalping screen, gator, crushing unit, or comparable sizing device approved by the Engineer shall be used in the RAS and FRAP feed system to remove or reduce oversized material.

If during mix production, corrective actions fail to maintain FRAP, RAS or QC/QA test results within control tolerances or the requirements listed herein the Contractor shall cease production of the mixture containing FRAP or RAS and conduct an investigation that may require a new mix design.

(a) RAS. RAS shall be incorporated into the HMA mixture either by a separate weight depletion system or by using the RAP weigh belt. Either feed system shall be interlocked with the aggregate feed or weigh system to maintain correct proportions for all rates of production and batch sizes. The portion of RAS shall be controlled accurately to within ± 0.5 percent of the amount of RAS utilized. When using the weight depletion system, flow indicators or sensing devices shall be provided and interlocked with the plant controls such that the mixture production is halted when RAS flow is interrupted.

(b) HMA Plant Requirements. HMA plants utilizing FRAP and/or RAS shall be capable of automatically recording and printing the following information.

(1) Dryer Drum Plants.

- a. Date, month, year, and time to the nearest minute for each print.
- b. HMA mix number assigned by the Department.
- c. Accumulated weight of dry aggregate (combined or individual) in tons (metric tons) to the nearest 0.1 ton (0.1 metric ton).
- d. Accumulated dry weight of RAS and FRAP in tons (metric tons) to the nearest 0.1 ton (0.1 metric ton).

**SECOND AVENUE SEWER SEPARATION
VILLAGE OF VILLA PARK**

- e. Accumulated mineral filler in revolutions, tons (metric tons), etc. to the nearest 0.1 unit.
 - f. Accumulated asphalt binder in gallons (liters), tons (metric tons), etc. to the nearest 0.1 unit.
 - g. Residual asphalt binder in the RAS and FRAP material as a percent of the total mix to the nearest 0.1 percent.
 - h. Aggregate RAS and FRAP moisture compensators in percent as set on the control panel. (Required when accumulated or individual aggregate and RAS and FRAP are printed in wet condition.)
 - i. When producing mixtures with FRAP and/or RAS, a positive dust control system shall be utilized.
 - j. Accumulated mixture tonnage.
 - k. Dust Removed (accumulated to the nearest 0.1 ton (0.1 metric ton))
- (2) Batch Plants.
- a. Date, month, year, and time to the nearest minute for each print.
 - b. HMA mix number assigned by the Department.
 - c. Individual virgin aggregate hot bin batch weights to the nearest pound (kilogram).
 - d. Mineral filler weight to the nearest pound (kilogram).
 - f. RAS and FRAP weight to the nearest pound (kilogram).
 - g. Virgin asphalt binder weight to the nearest pound (kilogram).
 - h. Residual asphalt binder in the RAS and FRAP material as a percent of the total mix to the nearest 0.1 percent.

The printouts shall be maintained in a file at the plant for a minimum of one year or as directed by the Engineer and shall be made available upon request. The printing system will be inspected by the Engineer prior to production and verified at the beginning of each construction season thereafter.

**SECOND AVENUE SEWER SEPARATION
VILLAGE OF VILLA PARK**

1031.09 RAP in Aggregate Surface Course and Aggregate Wedge Shoulders, Type B. The use of RAP or FRAP in aggregate surface course and aggregate shoulders shall be as follows.

- (a) Stockpiles and Testing. RAP stockpiles may be any of those listed in Article 1031.02, except “Non-Quality” and “FRAP”. The testing requirements of Article 1031.03 shall not apply. RAP used shall be according to the current Central Bureau of Materials Policy Memorandum, “Reclaimed Asphalt Pavement (RAP) for Aggregate Applications”.
- (b) Gradation. The RAP material shall meet the gradation requirements for CA 6 according to Article 1004.01(c), except the requirements for the minus No. 200 (75 µm) sieve shall not apply. The sample for the RAP material shall be air dried to constant weight prior to being tested for gradation.”

NOT FOR BIDDING

BDE SPECIAL PROVISIONS
For the April 27 and June 15, 2018 Lettings

The following special provisions indicated by an "x" are applicable to this contract and will be included by the Project Development and Implementation Section of the BD&E. An * indicates a new or revised special provision for the letting.

<u>File Name</u>	<u>#</u>	<u>Special Provision Title</u>	<u>Effective</u>	<u>Revised</u>
80099	1	Accessible Pedestrian Signals (APS)	April 1, 2003	Jan. 1, 2014
80382	2	Adjusting Frames and Grates	April 1, 2017	
80274	3	Aggregate Subgrade Improvement	April 1, 2012	April 1, 2016
80192	4	Automated Flagger Assistance Device	Jan. 1, 2008	
80173	5	Bituminous Materials Cost Adjustments	Nov. 2, 2006	Aug. 1, 2017
80241	6	Bridge Demolition Debris	July 1, 2009	
5026I	7	Building Removal-Case I (Non-Friable and Friable Asbestos)	Sept. 1, 1990	April 1, 2010
5048I	8	Building Removal-Case II (Non-Friable Asbestos)	Sept. 1, 1990	April 1, 2010
5049I	9	Building Removal-Case III (Friable Asbestos)	Sept. 1, 1990	April 1, 2010
5053I	10	Building Removal-Case IV (No Asbestos)	Sept. 1, 1990	April 1, 2010
80366	11	Butt Joints	July 1, 2016	
80386	12	Calcium Aluminate Cement for Class PP-5 Concrete Patching	Nov. 1, 2017	
80396	13	Class A and B Patching	Jan. 1, 2018	
80384	14	Compensable Delay Costs	June 2, 2017	
80198	15	Completion Date (via calendar days)	April 1, 2008	
80199	16	Completion Date (via calendar days) Plus Working Days	April 1, 2008	
80293	17	Concrete Box Culverts with Skews > 30 Degrees and Design Fills ≤ 5 Feet	April 1, 2012	July 1, 2016
80311	18	Concrete End Sections for Pipe Culverts	Jan. 1, 2013	April 1, 2016
80277	19	Concrete Mix Design – Department Provided	Jan. 1, 2012	April 1, 2016
80261	20	Construction Air Quality – Diesel Retrofit	June 1, 2010	Nov. 1, 2014
80387	21	Contrast Preformed Plastic Pavement Marking	Nov. 1, 2017	
80029	22	Disadvantaged Business Enterprise Participation	Sept. 1, 2000	July 2, 2016
80378	23	Dowel Bar Inserter	Jan. 1, 2017	Jan. 1, 2018
80388	24	Equipment Parking and Storage	Nov. 1, 2017	
80229	25	Fuel Cost Adjustment	April 1, 2009	Aug. 1, 2017
80304	26	Grooving for Recessed Pavement Markings	Nov. 1, 2012	Nov. 1, 2017
80246	27	Hot-Mix Asphalt – Density Testing of Longitudinal Joints	Jan. 1, 2010	April 1, 2016
80347	28	Hot-Mix Asphalt – Pay for Performance Using Percent Within Limits – Jobsite Sampling	Nov. 1, 2014	Jan. 1, 2018
80383	29	Hot-Mix Asphalt – Quality Control for Performance	April 1, 2017	Nov. 1, 2017
80376	30	Hot-Mix Asphalt – Tack Coat	Nov. 1, 2016	
80392	31	Lights on Barricades	Jan. 1, 2018	
80336	32	Longitudinal Joint and Crack Patching	April 1, 2014	April 1, 2016
80393	33	Manholes, Valve Vaults, and Flat Slab Tops	Jan. 1, 2018	
80045	34	Material Transfer Device	June 15, 1999	Aug. 1, 2014
* 80394	35	Metal Flared End Section for Pipe Culverts	Jan. 1, 2018	April 1, 2018
80165	36	Moisture Cured Urethane Paint System	Nov. 1, 2006	Jan. 1, 2010
80349	37	Pavement Marking Blackout Tape	Nov. 1, 2014	April 1, 2016
80371	38	Pavement Marking Removal	July 1, 2016	
80390	39	Payments to Subcontractors	Nov. 2, 2017	
80377	40	Portable Changeable Message Signs	Nov. 1, 2016	April 1, 2017
80389	41	Portland Cement Concrete	Nov. 1, 2017	
80359	42	Portland Cement Concrete Bridge Deck Curing	April 1, 2015	Nov. 1, 2017
80385	43	Portland Cement Concrete Sidewalk	Aug. 1, 2017	
80300	44	Preformed Plastic Pavement Marking Type D - Inlaid	April 1, 2012	April 1, 2016
80328	45	Progress Payments	Nov. 2, 2013	
3426I	46	Railroad Protective Liability Insurance	Dec. 1, 1986	Jan. 1, 2006

<u>File Name</u>	<u>#</u>	<u>Special Provision Title</u>	<u>Effective</u>	<u>Revised</u>
80157	47	Railroad Protective Liability Insurance (5 and 10)	Jan. 1, 2006	
80306	48	Reclaimed Asphalt Pavement (RAP) and Reclaimed Asphalt Shingles (RAS)	Nov. 1, 2012	Jan. 1, 2018
80395	49	Sloped Metal End Section for Pipe Culverts	Jan. 1, 2018	
80340	50	Speed Display Trailer	April 2, 2014	Jan. 1, 2017
80127	51	Steel Cost Adjustment	April 2, 2004	Aug. 1, 2017
80391	52	Subcontractor Mobilization Payments	Nov. 2, 2017	
80317	53	Surface Testing of Hot-Mix Asphalt Overlays	Jan. 1, 2013	April 1, 2016
80298	54	Temporary Pavement Marking (NOTE: This special provision was previously named "Pavement Marking Tape Type IV".)	April 1, 2012	April 1, 2017
20338	55	Training Special Provisions	Oct. 15, 1975	
80318	56	Traversable Pipe Grate for Concrete End Sections (NOTE: This special provision was previously named "Traversable Pipe Grate".)	Jan. 1, 2013	Jan. 1, 2018
80288	57	Warm Mix Asphalt	Jan. 1, 2012	April 1, 2016
80302	58	Weekly DBE Trucking Reports	June 2, 2012	April 2, 2015
80071	59	Working Days	Jan. 1, 2002	

The following special provisions are in the 2018 Supplemental Specifications and Recurring Special Provisions.

<u>File Name</u>	<u>Special Provision Title</u>	<u>New Location</u>	<u>Effective</u>	<u>Revised</u>
80368	Light Tower	Article 1069.08	July 1, 2016	
80369	Mast Arm Assembly and Pole	Article 1077.03(a)(1)	July 1, 2016	
80338	Portland Cement Concrete Partial Depth Hot-Mix Asphalt Patching	Recurring CS #35	April 1, 2014	April 1, 2016
80379	Steel Plate Beam Guardrail	Articles 630.02, 630.05, 630.06, and 630.08	Jan. 1, 2017	
80381	Traffic Barrier Terminal, Type 1 Special	Article 631.04	Jan. 1, 2017	
80380	Tubular Markers	Articles 701.03, 701.15, 701.18, and 1106.02	Jan. 1, 2017	

The following special provisions require additional information from the designer. The additional information needs to be submitted as a separate document. The Project Development and Implementation section will then include the information in the applicable special provision. The Special Provisions are:

- Bridge Demolition Debris
- Building Removal - Case I
- Building Removal - Case II
- Building Removal - Case III
- Building Removal-Case IV
- Completion Date
- Completion Date Plus Working Days
- DBE Participation
- Material Transfer Device
- Railroad Protective Liability Insurance
- Training Special Provisions
- Working Days

COMPLETION DATE (VIA CALENDAR DAYS) (BDE)

Effective: April 1, 2008

The Contractor shall complete all work on or before the completion date of this contract which will be based upon 60 calendar days.

The completion date will be determined by adding the specified number of calendar days to the date the Contractor begins work, or to the date ten days after execution of the contract, whichever is the earlier, unless a delayed start is granted by the Engineer.

80198

CONSTRUCTION AIR QUALITY – DIESEL RETROFIT (BDE)

Effective: June 1, 2010

Revised: November 1, 2014

The reduction of emissions of particulate matter (PM) for off-road equipment shall be accomplished by installing retrofit emission control devices. The term “equipment” refers to diesel fuel powered devices rated at 50 hp and above, to be used on the jobsite in excess of seven calendar days over the course of the construction period on the jobsite (including rental equipment).

Contractor and subcontractor diesel powered off-road equipment assigned to the contract shall be retrofitted using the phased in approach shown below. Equipment that is of a model year older than the year given for that equipment’s respective horsepower range shall be retrofitted:

Effective Dates	Horsepower Range	Model Year
June 1, 2010 ^{1/}	600-749	2002
	750 and up	2006
June 1, 2011 ^{2/}	100-299	2003
	300-599	2001
	600-749	2002
	750 and up	2006
June 1, 2012 ^{2/}	50-99	2004
	100-299	2003
	300-599	2001
	600-749	2002
	750 and up	2006

1/ Effective dates apply to Contractor diesel powered off-road equipment assigned to the contract.

2/ Effective dates apply to Contractor and subcontractor diesel powered off-road equipment assigned to the contract.

The retrofit emission control devices shall achieve a minimum PM emission reduction of 50 percent and shall be:

- a) Included on the U.S. Environmental Protection Agency (USEPA) *Verified Retrofit Technology List* (<http://www.epa.gov/cleandiesel/verification/verif-list.htm>), or verified by the California Air Resources Board (CARB) (<http://www.arb.ca.gov/diesel/verdev/vt/cvt.htm>); or
- b) Retrofitted with a non-verified diesel retrofit emission control device if verified retrofit emission control devices are not available for equipment proposed to be used on the project, and if the Contractor has obtained a performance certification from the retrofit

device manufacturer that the emission control device provides a minimum PM emission reduction of 50 percent.

Note: Large cranes (Crawler mounted cranes) which are responsible for critical lift operations are exempt from installing retrofit emission control devices if such devices adversely affect equipment operation.

Diesel powered off-road equipment with engine ratings of 50 hp and above, which are unable to be retrofitted with verified emission control devices or if performance certifications are not available which will achieve a minimum 50 percent PM reduction, may be granted a waiver by the Department if documentation is provided showing good faith efforts were made by the Contractor to retrofit the equipment.

Construction shall not proceed until the Contractor submits a certified list of the diesel powered off-road equipment that will be used, and as necessary, retrofitted with emission control devices. The list(s) shall include (1) the equipment number, type, make, Contractor/rental company name; and (2) the emission control devices make, model, USEPA or CARB verification number, or performance certification from the retrofit device manufacturer. Equipment reported as fitted with emissions control devices shall be made available to the Engineer for visual inspection of the device installation, prior to being used on the jobsite.

The Contractor shall submit an updated list of retrofitted off-road construction equipment as retrofitted equipment changes or comes on to the jobsite. The addition or deletion of any diesel powered equipment shall be included on the updated list.

If any diesel powered off-road equipment is found to be in non-compliance with any portion of this special provision, the Engineer will issue the Contractor a diesel retrofit deficiency deduction.

Any costs associated with retrofitting any diesel powered off-road equipment with emission control devices shall be considered as included in the contract unit prices bid for the various items of work involved and no additional compensation will be allowed. The Contractor's compliance with this notice and any associated regulations shall not be grounds for a claim.

Diesel Retrofit Deficiency Deduction

When the Engineer determines that a diesel retrofit deficiency exists, a daily monetary deduction will be imposed for each calendar day or fraction thereof the deficiency continues to exist. The calendar day(s) will begin when the time period for correction is exceeded and end with the Engineer's written acceptance of the correction. The daily monetary deduction will be \$1,000.00 for each deficiency identified.

The deficiency will be based on lack of diesel retrofit emissions control.

If a Contractor accumulates three diesel retrofit deficiency deductions for the same piece of equipment in a contract period, the Contractor will be shutdown until the deficiency is corrected.

Such a shutdown will not be grounds for any extension of the contract time, waiver of penalties, or be grounds for any claim.

80261

NOT FOR BID

HOT-MIX ASPHALT - DENSITY TESTING OF LONGITUDINAL JOINTS (BDE)

Effective: January 1, 2010

Revised: April 1, 2016

Description. This work shall consist of testing the density of longitudinal joints as part of the quality control/quality assurance (QC/QA) of hot-mix asphalt (HMA). Work shall be according to Section 1030 of the Standard Specifications except as follows.

Quality Control/Quality Assurance (QC/QA). Delete the second and third sentence of the third paragraph of Article 1030.05(d)(3) of the Standard Specifications.

Add the following paragraphs to the end of Article 1030.05(d)(3) of the Standard Specifications:

“Longitudinal joint density testing shall be performed at each random density test location. Longitudinal joint testing shall be located at a distance equal to the lift thickness or a minimum of 4 in. (100 mm), from each pavement edge. (i.e. for a 5 in. (125 mm) lift the near edge of the density gauge or core barrel shall be within 5 in. (125 mm) from the edge of pavement.) Longitudinal joint density testing shall be performed using either a correlated nuclear gauge or cores.

- a. Confined Edge. Each confined edge density shall be represented by a one-minute nuclear density reading or a core density and shall be included in the average of density readings or core densities taken across the mat which represents the Individual Test.
- b. Unconfined Edge. Each unconfined edge joint density shall be represented by an average of three one-minute density readings or a single core density at the given density test location and shall meet the density requirements specified herein. The three one-minute readings shall be spaced 10 ft (3 m) apart longitudinally along the unconfined pavement edge and centered at the random density test location.”

Revise the Density Control Limits table in Article 1030.05(d)(4) of the Standard Specifications to read:

“Mixture Composition	Parameter	Individual Test (includes confined edges)	Unconfined Edge Joint Density Minimum
IL-4.75	Ndesign = 50	93.0 – 97.4% ^{1/}	91.0%
IL-9.5	Ndesign = 90	92.0 – 96.0%	90.0%
IL-9.5,IL-9.5L	Ndesign < 90	92.5 – 97.4%	90.0%
IL-19.0	Ndesign = 90	93.0 – 96.0%	90.0%
IL-19.0, IL-19.0L	Ndesign < 90	93.0 ^{2/} – 97.4%	90.0%
SMA	Ndesign = 50 & 80	93.5 – 97.4%	91.0%”

HOT-MIX ASPHALT – TACK COAT (BDE)

Effective: November 1, 2016

Revise Article 1032.06(a) of the Standard Specifications to read:

“(a) Anionic Emulsified Asphalt. Anionic emulsified asphalts shall be according to AASHTO M 140. SS-1h emulsions used as a tack coat shall have the cement mixing test waived.”

80376

LIGHTS ON BARRICADES (BDE)

Effective: January 1, 2018

Revise Article 701.16 of the Standard Specifications to read:

“701.16 Lights. Lights shall be used on devices as required in the plans, the traffic control plan, and the following table.

Circumstance	Lights Required
Daylight operations	None
First two warning signs on each approach to the work involving a nighttime lane closure and “ROUGH GROOVED SURFACE” (W8-I107) signs	Flashing mono-directional lights
Devices delineating isolated obstacles, excavations, or hazards at night (Does not apply to patching)	Flashing bi-directional lights
Devices delineating obstacles, excavations, or hazards exceeding 100 ft (30 m) in length at night (Does not apply to widening)	Steady burn bi-directional lights
Channelizing devices for nighttime lane closures on two-lane roads	None
Channelizing devices for nighttime lane closures on multi-lane roads	None
Channelizing devices for nighttime lane closures on multi-lane roads separating opposing directions of traffic	None
Channelizing devices for nighttime along lane shifts on multilane roads	Steady burn mono-directional lights
Channelizing devices for night time along lane shifts on two lane roads	Steady burn bi-directional lights
Devices in nighttime lane closure tapers on Standards 701316 and 701321	Steady burn bi-directional lights
Devices in nighttime lane closure tapers	Steady burn mono-directional lights
Devices delineating a widening trench	None
Devices delineating patches at night on roadways with an ADT less than 25,000	None
Devices delineating patches at night on roadways with an ADT of 25,000 or more	None

Batteries for the lights shall be replaced on a group basis at such times as may be specified by the Engineer.”

Delete the fourth sentence of the first paragraph of Article 701.17(c)(2) of the Standard Specifications.

Revise the first paragraph of Article 603.07 of the Standard Specifications to read:

“603.07 Protection Under Traffic. After the casting has been adjusted and Class SI concrete has been placed, the work shall be protected by a barricade for at least 72 hours.”

80392

NOT FOR BID

MANHOLES, VALVE VAULTS, AND FLAT SLAB TOPS (BDE)

Effective: January 1, 2018

Description. This special provision applies to 6 ft, 7 ft, 8 ft, 9 ft, and 10 ft diameter manholes Type A; flat slab tops for inlets and catch basins; and valve vaults. This special provision also applies to 4 ft and 5 ft diameter manholes Type A manufactured after January 1, 2018 according to Highway Standards 602401-04 and 602402.

This special provision does not apply to 4' and 5' diameter manholes Type A and their associated flat slab tops, manufactured prior to January 1, 2018 according to Highway Standards 602401-03 and 602601-04. These manholes shall be according to the Standard Specifications and will be accepted until December 31, 2018.

Revise Article 602.02(g) of the Standard Specifications to read:

“(g) Structural Steel (Note 4) 1006.04

Note 4. All components of the manhole joint splice shall be galvanized according to the requirements of AASHTO M 111 or M 232 as applicable.”

Add the following to Article 602.02 of the Standard Specifications:

“(s) Anchor Bolts and Rods (Note 5) 1006.09

Note 5. The threaded rods for the manhole joint splice shall be according to the requirements of ASTM F 1554, Grade 55, (Grade 380).”

Add the following paragraph after the first paragraph of Article 602.07 of the Standard Specifications:

“Threaded rods connecting precast sections shall be brought to a snug tight condition.”

Revise the second paragraph of Article 1042.10 of the Standard Specifications to read:

“Catch basin Types A, B, C, and D; Manhole Type A; Inlet Types A and B; Drainage Structures Types 1, 2, 3, 4, 5, and 6; Valve Vault Type A; and reinforced concrete flat slab top (Highway Standard 602601) shall be according to AASHTO M 199 (M 199M), except the minimum wall thickness shall be 3 in. (75 mm). Additionally, catch basins, inlets, and drainage structures shall have a minimum concrete compressive strength of 4500 psi (31,000 kPa) at 28 days and manholes, valve vaults, and reinforced concrete flat slab tops shall have a minimum concrete compressive strength of 5000 psi (34,500 kPa) at 28 days.”

PORTLAND CEMENT CONCRETE (BDE)

Effective: November 1, 2017

Revise the Air Content % of Class PP Concrete in Table 1 Classes of Concrete and Mix Design Criteria in Article 1020.04 of the Standard Specifications to read:

Class of Conc.	Use	Air Content %
PP	Pavement Patching	4.0 - 8.0"
	Bridge Deck Patching (10)	
	PP-1	
	PP-2	
	PP-3	
	PP-4	
PP-5		

Revise Note (4) at the end of Table 1 Classes of Concrete and Mix Design Criteria in Article 1020.04 of the Standard Specifications to read:

"(4) For all classes of concrete, the maximum slump may be increased to 7 in (175 mm) when a high range water-reducing admixture is used. For Class SC, the maximum slump may be increased to 8 in. (200 mm). For Class PS, the maximum slump may be increased to 8 1/2 in. (215 mm) if the high range water-reducing admixture is the polycarboxylate type."

80389

PORTLAND CEMENT CONCRETE SIDEWALK (BDE)

Effective: August 1, 2017

Revise the first paragraph of Article 424.12 of the Standard Specifications to read:

“424.12 Method of Measurement. This work will be measured for payment in place and the area computed in square feet (square meters). Curb ramps, including side curbs and side flares, will be measured for payment as sidewalk. No deduction will be made for detectable warnings located within the ramp.”

80385

PROGRESS PAYMENTS (BDE)

Effective: November 2, 2013

Revise Article 109.07(a) of the Standard Specifications to read:

“(a) Progress Payments. At least once each month, the Engineer will make a written estimate of the quantity of work performed in accordance with the contract, and the value thereof at the contract unit prices. The amount of the estimate approved as due for payment will be vouchered by the Department and presented to the State Comptroller for payment. No amount less than \$1000.00 will be approved for payment other than the final payment.

Progress payments may be reduced by liens filed pursuant to Section 23(c) of the Mechanics' Lien Act, 770 ILCS 60/23(c).

If a Contractor or subcontractor has defaulted on a loan issued under the Department's Disadvantaged Business Revolving Loan Program (20 ILCS 2705/2705-610), progress payments may be reduced pursuant to the terms of that loan agreement. In such cases, the amount of the estimate related to the work performed by the Contractor or subcontractor, in default of the loan agreement, will be offset, in whole or in part, and vouchered by the Department to the Working Capital Revolving Fund or designated escrow account. Payment for the work shall be considered as issued and received by the Contractor or subcontractor on the date of the offset voucher. Further, the amount of the offset voucher shall be a credit against the Department's obligation to pay the Contractor, the Contractor's obligation to pay the subcontractor, and the Contractor's or subcontractor's total loan indebtedness to the Department. The offset shall continue until such time as the entire loan indebtedness is satisfied. The Department will notify the Contractor and Fund Control Agent in a timely manner of such offset. The Contractor or subcontractor shall not be entitled to additional payment in consideration of the offset.

The failure to perform any requirement, obligation, or term of the contract by the Contractor shall be reason for withholding any progress payments until the Department determines that compliance has been achieved.”

80328

State of Illinois
Department of Transportation
Bureau of Local Roads and Streets

SPECIAL PROVISION
FOR
BIDDING REQUIREMENTS AND CONDITIONS FOR CONTRACT PROPOSALS

Effective: January 1, 2001
Revised: January 2, 2012

All references to Sections or Articles in this specification shall be construed to mean specific Section or Article of the Standard Specifications for Road and Bridge Construction, adopted by the Department of Transportation.

Replace Article 102.01 of the Standard Specifications with the following:

“Prequalification of Bidders. When prequalification is required and the Awarding Authority for contract construction work is the County Board of a County, the Council, the City Council, or the President and Board of Trustees of a city, village, or town, each prospective bidder, in evidence of competence, shall furnish the Awarding Authority as a prerequisite to the release of proposal forms by the Awarding Authority, a certified or photostatic copy of a "Certificate of Eligibility" issued by the Department of Transportation, according to the Department's "Prequalification Manual".

The two low bidders must file, within 24 hours after the letting, a sworn affidavit in triplicate, showing all uncompleted contracts awarded to them and all low bids pending award for Federal, State, County, Municipal and private work, using the blank form made available for this affidavit. One copy shall be filed with the Awarding Authority and two copies with IDOT's District office.

Issuance of Proposal Forms. The Awarding Authority reserves the right to refuse to issue a proposal form for bidding purposes for any of the following reasons:

- (a) Lack of competency and adequate machinery, plant, and other equipment, as revealed by the financial statement and experience questionnaires required in the prequalification procedures.
- (b) Uncompleted work which, in the judgment of the Awarding Authority, might hinder or prevent the prompt completion of additional work awarded.
- (c) False information provided on a bidder's "Affidavit of Availability".
- (d) Failure to pay, or satisfactorily settle, all bills due for labor and material on former contracts in force at the time of issuance of proposal forms.
- (e) Failure to comply with any prequalification regulations of the Department.
- (f) Default under previous contracts.
- (g) Unsatisfactory performance record as shown by past work for the Awarding Authority, judged from the standpoint of workmanship and progress.
- (h) When the Contractor is suspended from eligibility to bid at a public letting where the contract is awarded by, or requires approval of, the Department.
- (i) When any agent, servant, or employee of the prospective bidder currently serves as a member, employee, or agent of a governmental body that is financially involved in the proposal work.

- (j) When any agent, servant, or employee of the perspective bidder has participated in the preparation of plans or specifications for the proposed work.

Interpretation of Quantities in the Bid Schedule. The quantities appearing in the bid schedule are approximate and are prepared for the comparison of bids. Payment to the Contractor will be made only for the actual quantities of work performed and accepted or materials furnished according to the contract. The scheduled quantities of work to be done and materials to be furnished may be increased, decreased, or omitted as hereinafter provided.

Examination of Plans, Specifications, Special Provisions, and Site of Work. The bidder shall, before submitting a bid, carefully examine the provisions of the contract. The bidder shall inspect in detail the site of the proposed work, investigate and become familiar with all the local conditions affecting the contract and fully acquaint themselves with the detailed requirements of construction. Submission of a bid shall be a conclusive assurance and warranty the bidder has made these examinations and the bidder understands all requirements for the performance of the work. If his/her bid is accepted, the bidder shall be responsible for all errors in the proposal resulting from his/her failure or neglect to comply with these instructions. The Awarding Authority will, in no case, be responsible for any costs, expenses, losses, or change in anticipated profits resulting from such failure or neglect of the bidder to make these examinations.

The bidder shall take no advantage of any error or omission in the proposal and advertised contract. Any prospective bidder, who desires an explanation or interpretation of the plans, specification, or any of the contract documents, shall request such in writing from the Awarding Authority, in sufficient time to allow a written reply by the Awarding Authority that can reach all prospective bidders before the submission of their bids. Any reply given a prospective bidder concerning any of the contract documents, plans, and specifications will be furnished to all prospective bidders in the form determined by the Awarding Authority including, but not limited to, an addendum, if the information is deemed by the Awarding Authority to be necessary in submitting bids or if the Awarding Authority concludes the information would aid competition. Oral explanations, interpretations, or instructions given before the submission of bids unless at a prebid conference will not be binding on the Awarding Authority.

Preparation of the Proposal. Bidders shall submit their proposals on the form furnished by the Awarding Authority. The proposal shall be executed properly, and bids shall be made for all items indicated in the proposal form, except when alternate bids are asked, a bid on more than one alternate for each item is not required, unless otherwise provided. The bidder shall indicate in figures, a unit price for each of the separate items called for in the proposal form; the bidder shall show the products of the respective quantities and unit prices in the column provided for that purpose, and the gross sum shown in the place indicated in the proposal form shall be the summation of said products. All writing shall be with ink or typewriter, except the signature of the bidder which shall be written in ink.

If the proposal is made by an individual, that individual's name and business address shall be shown. If made by a firm or partnership, the name and business address of each member of the firm or partnership shall be shown. If made by a corporation, the proposal shall show the names, titles, and business addresses of the president, corporate secretary and treasurer. The proposal shall be signed by president or someone with authority to execute contracts and attested by the corporate secretary or someone with authority to execute or attest to the execution of contracts.

When prequalification is required, the proposal form shall be submitted by an authorized bidder in the same name and style as shown on the "Contractor's Statement of Experience and Financial Condition" used for prequalification.

Rejection of Proposals. The Awarding Authority reserves the right to reject any proposal for any of the conditions in "Issuance of Proposal Forms" or for any of the following reasons:

- (a) More than one proposal for the same work from an individual, firm, partnership, or corporation under the same name or different names.
- (b) Evidence of collusion among bidders.
- (c) Unbalanced proposals in which the bid prices for some items are, in the judgment of the Awarding Authority, out of proportion to the bid prices for other items.
- (d) If the proposal does not contain a unit price for each pay item listed, except in the case of authorized alternate pay items or lump sum pay items.
- (e) If the proposal form is other than that furnished by the Awarding Authority; or if the form is altered or any part thereof is detached.
- (f) If there are omissions, erasures, alterations, unauthorized additions, conditional or alternate bids, or irregularities of any kind which may tend to make the proposal incomplete, indefinite or ambiguous as to its meaning.
- (g) If the bidder adds any provisions reserving the right to accept or reject an award, or to enter into a contract pursuant to an award.
- (h) If the proposal is not accompanied by the proper proposal guaranty.
- (i) If the proposal is prepared with other than ink or typewriter, or otherwise fails to meet the requirements of the above "Preparation of Proposal" section.

Proposal Guaranty. Each proposal shall be accompanied by a bid bond on the Department form contained in the proposal, executed by a corporate surety company satisfactory to the Awarding Authority, by a bank cashier's check or a properly certified check for not less than five percent of the amount bid, or for the amount specified in the following schedule:

<u>Amount Bid</u>		<u>Proposal Guaranty</u>
Up to	\$5,000	\$150
>\$5,000	\$10,000	\$300
>\$10,000	\$50,000	\$1,000
>\$50,000	\$100,000	\$3,000
>\$100,000	\$150,000	\$5,000
>\$150,000	\$250,000	\$7,500
>\$250,000	\$500,000	\$12,500
>\$500,000	\$1,000,000	\$25,000
>\$1,000,000	\$1,500,000	\$50,000
>\$1,500,000	\$2,000,000	\$75,000
>\$2,000,000	\$3,000,000	\$100,000
>\$3,000,000	\$5,000,000	\$150,000
>\$5,000,000	\$7,500,000	\$250,000
>\$7,500,000	\$10,000,000	\$400,000
>\$10,000,000	\$15,000,000	\$500,000
>\$15,000,000	\$20,000,000	\$600,000
>\$20,000,000	\$25,000,000	\$700,000
>\$25,000,000	\$30,000,000	\$800,000
>\$30,000,000	\$35,000,000	\$900,000
Over	\$35,000,000	\$1,000,000

In the event that one proposal guaranty check is intended to cover two or more proposals, the amount must equal to the sum of the proposal guaranties which would be required for each individual proposal.

Bank cashier's checks or properly certified checks accompanying proposals shall be made payable to the County Treasurer, when a County is the Awarding Authority; or the City, Village, or Town Treasurer, when a city, village, or town is the Awarding Authority.

The proposal guaranty checks of all, except the two lowest responsible, will be returned promptly after the proposals have been checked, tabulated, and the relation of the proposals established. Proposal guaranty checks of the two lowest bidders will be returned as soon as the contract and contract bond of the successful bidder have been properly executed and approved. Bid bonds will not be returned.

After a period of three working days has elapsed after the date of opening proposals, the Awarding Authority may permit the two lowest bidders to substitute for the bank cashier's checks or certified checks submitted with their proposals as proposal guaranties, bid bonds on the Department forms executed by corporate surety companies satisfactory to the Awarding Authority.

Delivery of Proposals. If a special envelope is supplied by the Awarding Authority, each proposal should be submitted in that envelope furnished by the Awarding Authority and the blank spaces on the envelope shall be filled in correctly to clearly indicate its contents. When an envelope other than the special one furnished by the Awarding Authority is used, it shall be marked to clearly indicate its contents. When sent by mail, the sealed proposal shall be addressed to the Awarding Authority at the address and in care of the official in whose office the bids are to be received. All proposals shall be filed prior to the time and at the place specified in the Notice to Bidders. Proposals received after the time specified will be returned to the bidder unopened.

Withdrawal of Proposals. Permission will be given a bidder to withdraw a proposal if the bidder makes the request in writing or in person before the time for opening proposals.

Public Opening of Proposals. Proposals will be opened and read publicly at the time and place specified in the Notice to Bidders. Bidders, their authorized agents, and other interested parties are invited to be present.

Consideration of Proposals. After the proposals are opened and read, they will be compared on the basis of the summation of the products of the quantities shown in the bid schedule by the unit bid prices. In awarding contracts, the Awarding Authority will, in addition to considering the amounts stated in the proposals, take into consideration the responsibility of the various bidders as determined from a study of the data required under "Prequalification of Bidders", and from other investigations which it may elect to make.

The right is reserved to reject any or all proposals, to waive technicalities, or to advertise for new proposals, if in the judgment of the Awarding Authority, the best interests of the Awarding Authority will be promoted thereby.

Award of Contract. The award of contract will be made within 45 calendar days after the opening of proposals to the lowest responsible and qualified bidder whose proposal complies with all the requirements prescribed. The successful bidder will be notified by letter of intent that his/her bid has been accepted, and subject to the following conditions, the bidder will be the Contractor.

An approved contract executed by the Awarding Authority is required before the Awarding Authority is bound. An award may be cancelled any time by the Awarding Authority prior to execution in order to protect the public interest and integrity of the bidding process or for any other reason if, in the judgment of the Awarding Authority, the best interests of the Awarding Authority will be promoted thereby.

If a contract is not awarded within 45 days after the opening of proposals, bidders may file a written request with the Awarding Authority for the withdrawal of their bid, and the Awarding Authority will permit such withdrawal.

Requirement of Contract Bond. The Contractor shall furnish the Awarding Authority a performance and payment bond with good and sufficient sureties in the full amount of the contract as the penal sum. The surety shall be acceptable to the Awarding Authority, shall waive notice of any changes and extensions of time, and shall submit its bond on the form furnished by the Awarding Authority.

Execution of Contract. The contract shall be executed by the successful bidder and returned, together with the Contract Bond, within 15 days after the contract has been mailed to the bidder.

If the bidder to whom the award is made is a corporation organized under the laws of a State other than Illinois, the bidder shall furnish the Awarding Authority a copy of the corporation's Certificate of Authority to do business in the State of Illinois with the return of the executed contract and bond. Failure to furnish such evidence of a Certificate of Authority within the time required will be considered as just cause for the annulment of the award and the forfeiture of the proposal guaranty to the Awarding Authority, not as a penalty, but in payment of liquidated damages sustained as a result of such failure.

Failure to Execute Contract. If the contract is not executed by the Awarding Authority within 15 days following receipt from the bidder of the properly executed contracts and bonds, the bidder shall have the right to withdraw his/her bid without penalty.

Failure of the successful bidder to execute the contract and file acceptable bonds within 15 days after the contract has been mailed to the bidder shall be just cause for the cancellation of the award and the forfeiture of the proposal guaranty which shall become the property of the Awarding Authority, not as penalty, but in liquidation of damages sustained. Award may then be made to the next lowest responsible bidder, or the work may be readvertised and constructed under contract, or otherwise, as the Awarding Authority may decide.”

State of Illinois
Department of Transportation
Bureau of Local Roads and Streets

SPECIAL PROVISION
FOR
COOPERATION WITH UTILITIES

Effective: January 1, 1999
Revised: January 1, 2007

All references to Sections or Articles in this specification shall be construed to mean specific Section or Article of the Standard Specifications for Road and Bridge Construction, adopted by the Department of Transportation.

Replace Article 105.07 of the Standard Specifications with the following:

“105.07 Cooperation with Utilities. The adjustment of utilities consists of the relocation, removal, replacement, rearrangements, reconstruction, improvement, disconnection, connection, shifting, new installation or altering of an existing utility facility in any manner.

When the plans or special provisions include information pertaining to the location of underground utility facilities, such information represents only the opinion of the Department as to the location of such utilities and is only included for the convenience of the bidder. The Department assumes no responsibility in respect to the sufficiency or the accuracy of the information shown on the plans relative to the location of the underground utility facilities.

Utilities which are to be adjusted shall be adjusted by the utility owner or the owner's representative or by the Contractor as a contract item. Generally, arrangements for adjusting existing utilities will be made by the Department prior to project construction; however, utilities will not necessarily be adjusted in advance of project construction and, in some cases, utilities will not be removed from the proposed construction limits. When utility adjustments must be performed in conjunction with construction, the utility adjustment work will be shown on the plans and/or covered by Special Provisions.

When the Contractor discovers a utility has not been adjusted by the owner or the owner's representative as indicated in the contract documents, or the utility is not shown on the plans or described in the Special Provisions as to be adjusted in conjunction with construction, the Contractor shall not interfere with said utility, and shall take proper precautions to prevent damage or interruption of the utility and shall promptly notify the Engineer of the nature and location of said utility.

All necessary adjustments, as determined by the Engineer, of utilities not shown on the plans or not identified by markers, will be made at no cost to the Contractor except traffic structures, light poles, etc., that are normally located within the proposed construction limits as hereinafter defined will not be adjusted unless required by the proposed improvement.

- (a) Limits of Proposed Construction for Utilities Paralleling the Roadway. For the purpose of this Article, limits of proposed construction for utilities extending in the same longitudinal direction as the roadway, shall be defined as follows:
- (1) The horizontal limits shall be a vertical plane, outside of, parallel to, and 600 mm (2 ft) distant at right angles from the plan or revised slope limits.
- In cases where the limits of excavation for structures are not shown on the plans, the horizontal limits shall be a vertical plane 1.2 m (4 ft) outside the edges of structure footings or the structure where no footings are required.
- (2) The upper vertical limits shall be the regulations governing the roadbed clearance for the specific utility involved.
 - (3) The lower vertical limits shall be the top of the utility at the depth below the proposed grade as prescribed by the governing agency or the limits of excavation, whichever is less.
- (b) Limits of Proposed Construction for Utilities Crossing the Roadway. For the purpose of this Article, limits of proposed construction for utilities crossing the roadway in a generally transverse direction shall be defined as follows:
- (1) Utilities crossing excavations for structures that are normally made by trenching such as sewers, underdrains, etc. and all minor structures such as manholes, inlets, foundations for signs, foundations for traffic signals, etc., the limits shall be the space to be occupied by the proposed permanent construction unless otherwise required by the regulations governing the specific utility involved.
 - (2) For utilities crossing the proposed site of major structures such as bridges, sign trusses, etc., the limits shall be as defined above for utilities extending in the same general direction as the roadway.

The Contractor may make arrangements for adjustment of utilities outside of the limits of proposed construction provided the Contractor furnishes the Department with a signed agreement with the utility owner covering the adjustments to be made. The cost of any adjustments made outside the limits of proposed construction shall be the responsibility of the Contractor unless otherwise provided.

The Contractor shall request all utility owners to field locate their facilities according to Article 107.31. The Engineer may make the request for location from the utility after receipt of notice from the Contractor. On request, the Engineer will make an inspection to verify that the utility company has field located its facilities, but will not assume responsibility for the accuracy of such work. The Contractor shall be responsible for maintaining the excavations or markers provided by the utility owners. This field location procedure may be waived if the utility owner has stated in writing to the Department it is satisfied the construction plans are sufficiently accurate. If the utility owner does not submit such statement to the Department, and they do not field locate their facilities in both horizontal and vertical alignment, the Engineer will authorize the Contractor in writing to proceed to locate the facilities in the most economical and reasonable manner, subject to the approval of the Engineer, and be paid according to Article 109.04.

The Contractor shall coordinate with any planned utility adjustment or new installation and the Contractor shall take all precautions to prevent disturbance or damage to utility facilities. Any failure on the part of the utility owner, or their representative, to proceed with any planned utility adjustment or new installation shall be reported promptly by the Contractor to the Engineer orally and in writing.

The Contractor shall take all necessary precautions for the protection of the utility facilities. The Contractor shall be responsible for any damage or destruction of utility facilities resulting from neglect, misconduct, or omission in the Contractor's manner or method of execution or nonexecution of the work, or caused by defective work or the use of unsatisfactory materials. Whenever any damage or destruction of a utility facility occurs as a result of work performed by the Contractor, the utility company will be immediately notified. The utility company will make arrangements to restore such facility to a condition equal to that existing before any such damage or destruction was done.

It is understood and agreed that the Contractor has considered in the bid all of the permanent and temporary utilities in their present and/or adjusted positions.

No additional compensation will be allowed for any delays, inconvenience, or damage sustained by the Contractor due to any interference from the said utility facilities or the operation of relocating the said utility facilities.

NOT FOR BIDDING

State of Illinois
Department of Transportation
Bureau of Local Roads and Streets

SPECIAL PROVISION
FOR
INSURANCE

Effective: February 1, 2007
Revised: August 1, 2007

All references to Sections or Articles in this specification shall be construed to mean specific Section or Article of the Standard Specifications for Road and Bridge Construction, adopted by the Department of Transportation.

The Contractor shall name the following entities as additional insured under the Contractor's general liability insurance policy in accordance with Article 107.27:

VILLAGE OF VILLA PARK

The entities listed above and their officers, employees, and agents shall be indemnified and held harmless in accordance with Article 107.26.

State of Illinois
DEPARTMENT OF TRANSPORTATION
Bureau of Local Roads & Streets

SPECIAL PROVISION
FOR
WAGES OF EMPLOYEES ON PUBLIC WORKS

Effective: January 1, 1999
Revised: January 1, 2012

1. Prevailing Wages. All wages paid by the Contractor and each subcontractor shall be in compliance with The Prevailing Wage Act (820 ILCS 130), as amended, except where a prevailing wage violates a federal law, order, or ruling, the rate conforming to the federal law, order, or ruling shall govern. The Contractor shall be responsible to notify each subcontractor of the wage rates set forth in this contract and any revisions thereto. If the Department of Labor revises the wage rates, the revised rate as provided by the public body shall apply to this contract and the Contractor will not be allowed additional compensation on account of said revisions.
2. Payroll Records. The Contractor and each subcontractor shall make and keep, for a period of not less than three years from the date of the last payment on a contract or subcontract, records of all laborers, mechanics, and other workers employed by them on the project; the records shall include each worker's name, address, telephone number when available, social security number, classification or classifications, the hourly wages paid in each pay period, the number of hours worked each day, and the starting and ending times of work each day. Upon seven business days' notice, the Contractor and each subcontractor shall make available for inspection and copying at a location within this State during reasonable hours, the payroll records to the public body in charge of the project, its officers and agents, the Director of Labor and his deputies and agents, and to federal, State, or local law enforcement agencies and prosecutors.
3. Submission of Payroll Records. The Contractor and each subcontractor shall no later than the tenth day of each calendar month file a certified payroll for the immediately preceding month with the public body in charge of the project, except that the full social security number and home address shall not be included on weekly transmittals. Instead the payrolls shall include an identification number for each employee (e.g., the last four digits of the employee's social security number). The certified payroll shall consist of a complete copy of the payroll records except starting and ending times of work each day may be omitted

The certified payroll shall be accompanied by a statement signed by the Contractor or subcontractor or an officer, employee, or agent of the contractor or subcontractor which avers that: (i) he or she has examined the certified payroll records required to be submitted by the Act and such records are true and accurate; (ii) the hourly rate paid to each worker is not less than the general prevailing rate of hourly wages required; and (iii) the Contractor or subcontractor is aware that filing a certified payroll that he or she knows to be false is a Class A misdemeanor.
4. Employees Interviews. The Contractor and each subcontractor shall permit his/her employees to be interviewed on the job, during working hours, by compliance investigators of the Department or the Department of Labor.

State of Illinois
Department of Transportation
Bureau of Local Roads and Streets

SPECIAL PROVISION
FOR
EQUIPMENT RENTAL RATES

Effective: January 1, 2012

All references to Sections or Articles in this specification shall be construed to mean a specific Section or Article of the Standard Specifications for Road and Bridge Construction, adopted by the Department of Transportation.

Replace Article 109.04(b)(4) with the following:



































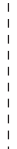







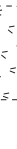

- "(4) Equipment. For any machinery or special equipment (other than small tools) the use of which has been authorized by the Engineer, the Contractor will be paid according to the latest revision of "SCHEDULE OF AVERAGE ANNUAL EQUIPMENT OWNERSHIP EXPENSE" and latest index factor as issued by the Illinois Department of Transportation. The equipment should be of a type and size reasonably required to complete the extra work."

NOT FOR BID

ADJUSTMENT ITEMS	EX	PR	ALIGNMENT ITEMS	EX	PR	CONTOUR ITEMS	EX	PR
Structure To Be Adjusted		ADJ	Baseline	_____	_____	Approx. Index Line	_____	_____
Structure To Be Cleaned		C	Centerline	_____	_____	Approx. Intermediate Line	_____	_____
Main Structure To Be Filled		FM	Centerline Break Circle	○	○	Index Contour	_____	_____
Structure To Be Filled		F	Baseline Symbol			Intermediate Contour	_____	_____
Structure To Be Filled Special		FSP	Centerline Symbol	⊥	⊥	DRAINAGE ITEMS		
Structure To Be Removed		R	PI Indicator	△	△	Channel or Stream Line	_____	_____
Structure To Be Reconstructed		REC	Point Indicator	○	○	Culvert Line	-----	-----
Structure To Be Reconstructed Special		RSP	Horizontal Curve Data (Half Size)			Grading & Shaping Ditches	-----	-----
Frame and Grate To Be Adjusted		A	BOUNDARIES ITEMS			Drainage Boundary Line	////	////
Frame and Lid To Be Adjusted		A	Dashed Property Line	----	----	Paved Ditch	=====	=====
Domestic Service Box To Be Adjusted		A	Solid Property/Lot Line	_____	_____	Aggregate Ditch	=====	=====
Valve Vault To Be Adjusted		A	Section/Grant Line	----	----	Pipe Underdrain	-----	-----
Special Adjustment		SP	Quarter Section Line	----	----	Storm Sewer	-----	-----
Item To Be Abandoned		AB	Quarter/Quarter Section Line	----	----	Flowline	⬅️	➡️
Item To Be Moved		M	County/Township Line	----	----	Ditch Check	⬅️	➡️
Item To Be Relocated		REL	State Line	----	----	Inlet	□	□
Pavement Removal and Replacement		REL	Iron Pipe Found	○	○	Manhole	⊙	⊙
			Iron Pipe Set	●	●	Roadway Ditch Flow	↔️	↔️
			Survey Marker	⊙	⊙	Swale	~>	~>
			Property Line Symbol	⊥	⊥	Catch Basin	○	●
			Same Ownership Symbol (Half Size)	↗️	↗️	Culvert End Section	△	△
			Northwest Quarter Corner (Half Size)			Water Surface Indicator	▽	▽
			Section Corner (Half Size)			Riprap		
			Southeast Quarter Corner (Half Size)					

Illinois Department of Transportation
 PASSED January 3, 2011
Michael Board
 ENGINEER OF POLICY AND PROCEDURES
 APPROVED January 3, 2011
Scott Kelly
 ENGINEER OF DESIGN AND ENVIRONMENT
 ISSUE# 1-1-97

**STANDARD SYMBOLS,
 ABBREVIATIONS
 AND PATTERNS**
 (Sheet 2 of 8)
STANDARD 000001-06

EROSION & SEDIMENT CONTROL ITEMS	NON-HIGHWAY IMPROVEMENT ITEMS	EXISTING LANDSCAPING ITEMS (contd.)
EX	EX	EX
PR	PR	PR
<p>Cleaning & Grading Limits </p> <p>Dike </p> <p>Erosion Control Fence </p> <p>Perimeter Erosion Barrier </p> <p>Temporary Fence </p> <p>Ditch Check Temporary </p> <p>Ditch Check Permanent </p> <p>Inlet & Pipe Protection </p> <p>Sediment Basin </p> <p>Erosion Control Blanket </p> <p>Fabric Formed Concrete Reveiment Mat </p> <p>Turf Reinforcement Mat </p> <p>Mulch Temporary </p> <p>Mulch Method 1 </p> <p>Mulch Method 2 Stabilized </p> <p>Mulch Method 3 Hydraulic </p>	<p>Noise Attn./Levee </p> <p>Field Line </p> <p>Fence </p> <p>Base of Levee </p> <p>Mailbox </p> <p>Multiple Mailboxes </p> <p>Pay Telephone </p> <p>Advertising Sign </p> <p>Contour Mounding Line </p> <p>Fence </p> <p>Fence Post </p> <p>Shrubs </p> <p>Mowline </p> <p>Perennial Plants </p> <p>Seeding Class 2 </p> <p>Seeding Class 2A </p> <p>Seeding Class 4 </p> <p>Seeding Class 4 & 5 Combined </p>	<p>Seeding Class 5 </p> <p>Seeding Class 7 </p> <p>Seedlings Type 1 </p> <p>Seedlings Type 2 </p> <p>Sodding </p> <p>Movestake w/Sign </p> <p>Tree Trunk Protection </p> <p>Evergreen Tree </p> <p>Shade Tree </p> <p>LIGHTING</p> <p>Conduit </p> <p>Duct </p> <p>Electrical Aerial Cable </p> <p>Electrical Buried Cable </p> <p>Controller </p> <p>Underpass Luminaire </p> <p>Power Pole </p>

STANDARD SYMBOLS, ABBREVIATIONS AND PATTERNS
 (Sheet 3 of 8)
 STANDARD 000001-06

Illinois Department of Transportation
 PASSED January 3, 2011
 Nicholas Bond
 ENGINEER OF POLICY AND PROCEDURES
 APPROVED January 3, 2011
 Scott S. V.
 ENGINEER OF DESIGN AND ENVIRONMENT
 ISSUE 1-1-97

**LIGHTING
(contd.)**

	EX	PR
Pull Point		
Handhole		
Heavy Duty Handhole		
Junction Box		
Light Unit Comb.		
Electrical Ground		
Traffic Flow Arrow		
High Mast Pole (Half Size)		
Light Unit-1		

PAVEMENT (MISC.)

	EX	PR
Keyed Long, Joint		
Keyed Long, Joint w/The Bars		
Sawed Long, Joint w/The Bars		
Bluminous Shoulder		
Bluminous Taper		
Stabilized Driveway		
Widening		

PAVEMENT MARKINGS

	EX	PR
Bike Lane Symbol		
Bike Lane Text		
Handicap Symbol		
RR Crossing		
Raised Marker Amber 1 Way		
Raised Marker Amber 2 Way		
Raised Marker Crystal 1 Way		
Two Way Turn Left		
Shoulder Diag- Pattern		
Skip-Dash White		
Skip-Dash Yellow		
Stop Line		
Solid Line		
Double Centerline		
Dotted Lines		
CL 2Ln 2Way RRPM 12.2 m (40') o.c.		
CL 2Ln 2Way RRPM 80' (24.4 m) o.c.		
CL Multilane Div. RRPM 40' (12.2 m) o.c.		
CL Multilane Div. RRPM 80' (24.4 m) o.c.		
CL Multilane Div. DBL. RRPM 80' (24.4 m) o.c.		
CL Multilane Unblk.		
Two Way Turn Left Line		

Illinois Department of Transportation
 PASSED January 3, 2011
 Nicholas Board
 ENGINEER OF POLICY AND PROCEDURES
 APPROVED January 3, 2011
 S. J. [Signature]
 ENGINEER OF DESIGN AND ENVIRONMENT
 ISSUE# 1-1-97

**STANDARD SYMBOLS,
ABBREVIATIONS
AND PATTERNS**
 (Sheet 4 of 8)
 STANDARD 000001-06

PAVEMENT MARKINGS
(cont'd.)

	EX	PR
Urban Combination Left		
Urban Combination Right		
Urban Left Turn Arrow		
Urban Right Turn Arrow		
Urban Left Turn Only		
Urban Right Turn Only		
Urban Thru Only		
Urban U-Turn		
Urban Combined U-Turn		
Rural Combination Left		
Rural Combination Right		
Rural Left Turn Arrow		
Rural Right Turn Arrow		
Rural Left Turn Only		
Rural Right Turn Only		
Rural Thru Only		

Illinois Department of Transportation
 PASSED January 3, 2011
 Nicholas Board
 ENGINEER OF POLICY AND PROCEDURES
 APPROVED January 3, 2011
 S. J. [Signature]
 ENGINEER OF DESIGN AND ENVIRONMENT
 ISSUE# 1-1-97

RAILROAD ITEMS

	EX	PR
Abandoned Railroad		
Railroad		
Railroad Point		
Control Box		
Crossing Gate		
Flashing Signal		
Railroad Cant, Mast Arm		
Crossbuck		

REMOVAL ITEMS

	EX	PR
Removal T/C		
Bituminous Removal		
Hatch Pattern		
Tree Removal Single		

RIGHT OF WAY ITEMS

	EX	PR
Future ROW Corner Monument		
ROW Marker		
ROW Line		
Easement		
Temporary Easement		

STANDARD SYMBOLS, ABBREVIATIONS AND PATTERNS
(Sheet 5 of 8)

STANDARD 000001-06

RIGHT OF WAY ITEMS (contd.)	ROADWAY PROFILES	SIGNING ITEMS (contd.)
EX	EX	EX
PR	PR	PR
Access Control Line AC	P.L. Indicator A	Reverse Left W1-4L (Half Size)
Access Control Line & ROW AC	Point Indicator o	Reverse Right W1-4R (Half Size)
Access Control Line & ROW with Fence AC	Earthworks Balance Point o	Two Way Traffic Sign W6-3 (Half Size)
Excess ROW Line XS	Begin Point D	Detour Ahead W20-2(O) (Half Size)
ROADWAY PLAN ITEMS	Vert. Curve Data VPI = ELEV = E =	Left Lane Closed Ahead W20-5(L) (Half Size)
Cable Barrier EX PR	Ditch Profile Left Side Dotted line	Right Lane Closed Ahead W20-5(R) (Half Size)
Concrete Barrier EX PR	Ditch Profile Right Side Dotted line	Road Closed Ahead W20-3(O) (Half Size)
Edge of Pavement EX PR	Roadway Profile Line Dashed line	Road Construction Ahead W20-1(O) (Half Size)
Bit Shoulders, Medians and C&G Line EX PR	Storm Sewer Profile Left Side Dashed line	Single Lane Ahead (Half Size)
Aggregate Shoulder EX PR	Storm Sewer Profile Right Side Dashed line	Transition Left W4-2L (Half Size)
Sidewalks, Driveways EX PR	SIGNING ITEMS	Transition Right W4-2R (Half Size)
Guardrail EX PR	Cone, Drum or Barricade o	Typical Cross-Section Line Dashed line
Guardrail Post EX PR	Barricade Type II Hatched rectangle	Typical Cross-Section Line Dashed line
Traffic Sign EX PR	Barricade Type III TT	Typical Cross-Section Line Dashed line
Corrugated Median EX PR	Barricade With Edge Line Line with circles	Typical Cross-Section Line Dashed line
Impact Attenuator EX PR	Flashing Light Sign Circle with vertical lines	Typical Cross-Section Line Dashed line
North Arrow with District Office (Half Size) N	Panels I Vertical bar with diagonal lines	Typical Cross-Section Line Dashed line
March Line STA. 45+00	Panels II Vertical bar	Typical Cross-Section Line Dashed line
Slope Limit Line Dashed line	Direction of Traffic Arrow	Typical Cross-Section Line Dashed line
Typical Cross-Section Line Dashed line	Sign Flag (Half Size) Diamond	Typical Cross-Section Line Dashed line

STANDARD SYMBOLS, ABBREVIATIONS AND PATTERNS
(Sheet 6 of 8)
STANDARD 000001-06

SIGNING ITEMS (contd.)	EX	PR	STRUCTURES ITEMS	EX	PR	TRAFFIC SHEET ITEMS	EX	PR
One Way Arrow Upr. W1-6-(O) (Half Size)			Box Culvert Barrel	-----	-----	Cable Number		
Two Way Arrow Large W1-7-(O) (Half Size)			Box Culvert Headwall	-----	-----	Left Turn Green		
Detour M4-10L-(O) (Half Size)			Bridge Pier	-----	-----	Left Turn Yellow		
Detour M4-10R-(O) (Half Size)			Retaining Wall	-----	-----	Signal Backplate		
One Way Left R6-1L (Half Size)			Temporary Sheet Piling	-----	~~~~~	Signal Section 8" (200 mm)		
One Way Right R6-1R (Half Size)						Signal Section 12" (300 mm)		
Left Turn Lane R3-100L (Half Size)						Walk/Don't Walk Letters		
Keep Left R4-7AL (Half Size)						Walk/Don't Walk Symbols		
Keep Left R4-7BL (Half Size)						TRAFFIC SIGNAL ITEMS		
Keep Right R4-7AR (Half Size)						Galv. Steel Conduit		
Keep Right R4-7BR (Half Size)						Underground Cable		
Stop Here On Red R10-6-AL (Half Size)						Detector Loop Line		
Stop Here On Red R10-6-AR (Half Size)						Detector Loop Large		
No Left Turn R3-2 (Half Size)						Detector Loop Small		
No Right Turn R3-1 (Half Size)						Detector Loop Quadrangle		
Road Closed R11-2 (Half Size)								
Road Closed Thru Traffic R11-2 (Half Size)								

Illinois Department of Transportation
 PASSED January 1, 2011
Michael Beard
 ENGINEER OF POLICY AND PROCEDURES
 APPROVED January 1, 2011
Scott S. X
 ENGINEER OF DESIGN AND ENVIRONMENT
 ISSUE# 1-1-97

**STANDARD SYMBOLS,
 ABBREVIATIONS
 AND PATTERNS**
 (Sheet 7 of 8)
STANDARD 000001-06

TRAFFIC SIGNAL ITEMS (contd.)	EX	PR
Detector Raceway		
Aluminum Mast Arm		
Steel Mast Arm		
Veh. Detector Magnetic		
Conduit Splice		
Controller		
Galftbox Junction		
Wood Pole		
Temp. Signal Head		
Handhole		
Double Handhole		
Heavy Duty Handhole		
Junction Box		
Red. Pushbutton Detector		
Red. Signal Head		
Power Pole Service		
Priority Veh. Detector		
Signal Head		
Signal Head w/backplate		
Signal Post		
Closed Circuit TV		
Video Detector System		

UNDERGROUND UTILITY ITEMS	EX	PR	ABANDONED
Cable TV			
Electric Cable			
Fiber Optic			
Gas Pipe			
Oil Pipe			
Sanitary Sewer			
Telephone Cable			
Water Pipe			
UTILITIES ITEMS			
Controller			
Double Handhole			
Fire Hydrant			
GuyWire or Deadman Anchor			
Handhole			
Heavy Duty Handhole			
Junction Box			
Light Pole			
Manhole			
Pipeline Warning Sign			
Power Pole			
Power Pole with Light			
Sanitary Sewer Cleanout			
Splice Box Above Ground			
Telephone Splice Box Above Ground			
Telephone Pole			

UTILITY ITEMS (contd.)	EX	PR
Traffic Signal		
Traffic Signal Control Box		
Water Meter		
Water Meter Valve Box		
Profile Line		
Aerial Power Line		
VEGETATION ITEMS		
Deciduous Tree		
Bush or Shrub		
Evergreen Tree		
Stump		
Orchard/Nursery Line		
Vegetation Line		
Woods & Bush Line		
WATER FEATURE ITEMS		
Stream or Drainage Ditch		
Waters Edge		
Water Surface Indicator		
Water Point		
Disappearing Ditch		
Marsh		
Marsh/Swamp Boundary		

**STANDARD SYMBOLS,
ABBREVIATIONS
AND PATTERNS**
(Sheet 8 of 8)
STANDARD 000001-06

ILLINOIS Department of Transportation
 PASSED January 3, 2011
Michael Board
 ENGINEER OF POLICY AND PROCEDURES
 APPROVED January 3, 2011
Scott S. V.
 ENGINEER OF DESIGN AND ENVIRONMENT
 ISSUE# 1-1-97

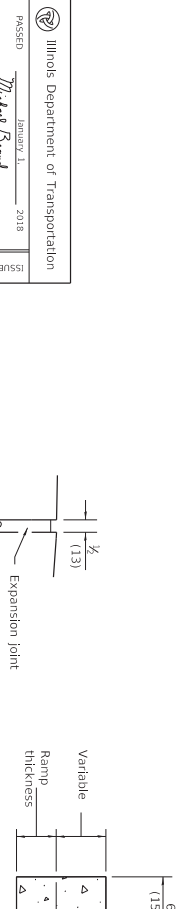
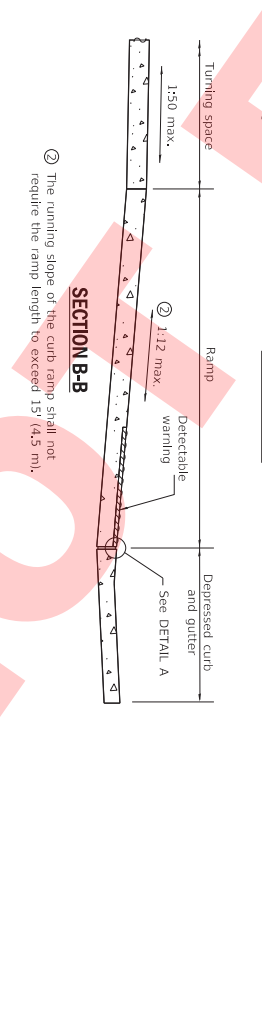
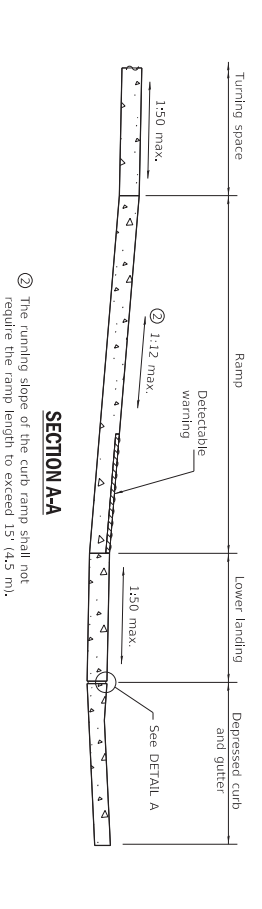
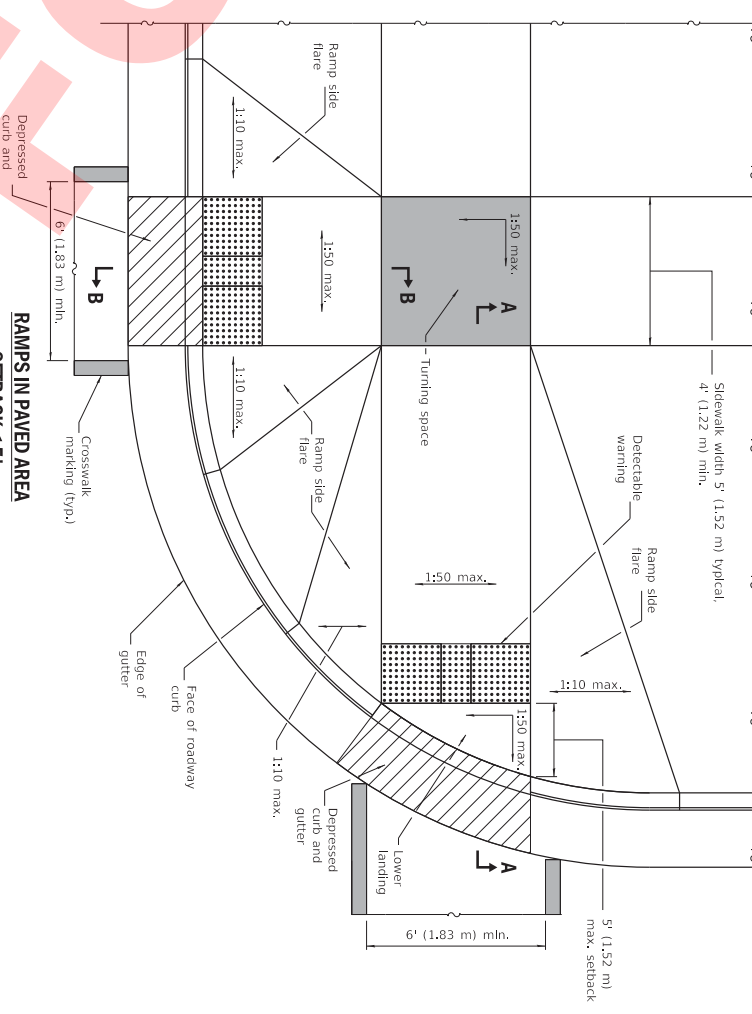
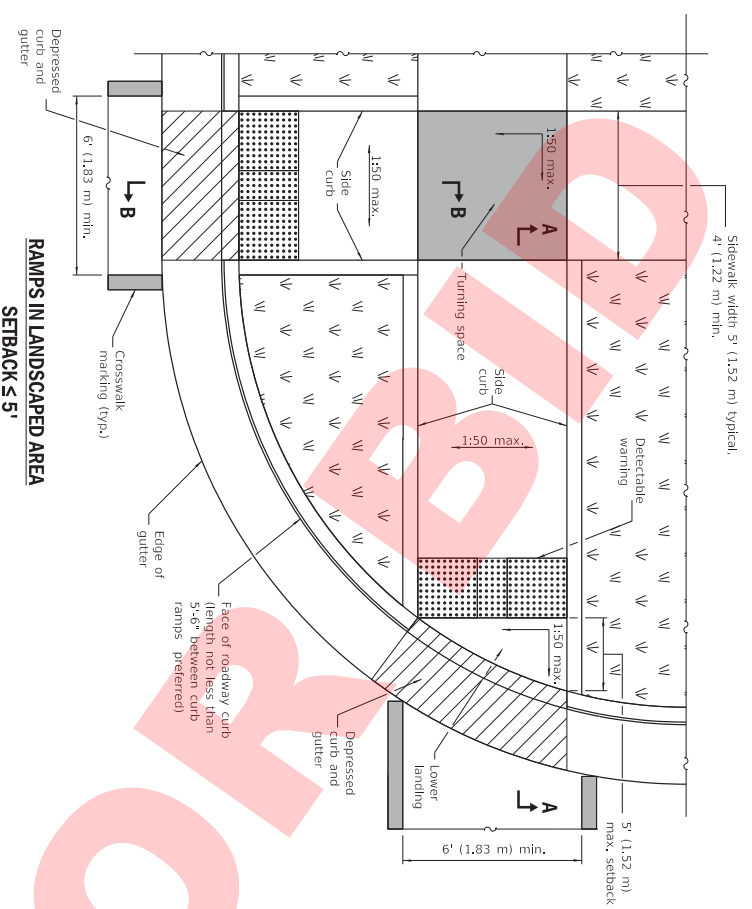

Illinois Department of Transportation
 PASSED January 1, 2018
 APPROVED *Michael Brand* January 1, 2018
 ENGINEER OF POLICY AND PROCEDURES
 APPROVED *Matthew N. Davis* January 1, 2018
 ENGINEER OF DESIGN AND ENVIRONMENT
 ISSUE# 1-1-97

DETAIL A

SIDE CURB DETAIL

DATE	REVISIONS
1-1-18	Omitted diagonal slope at turning spaces and lower landings.
1-1-17	Added 2" dimension to det. warnings for setbacks greater than 5'.

PERPENDICULAR CURB RAMPS FOR SIDEWALKS
 (Sheet 1 of 2)
 STANDARD 424001-10
 See Sheet 2 for GENERAL NOTES.

Illinois Department of Transportation
 PASSED January 3, 2011
 ENGINEER OF POLICY AND PROCEDURES
 APPROVED January 3, 2011
 ENGINEER OF DESIGN AND ENVIRONMENT

ISSUED 1-1-07

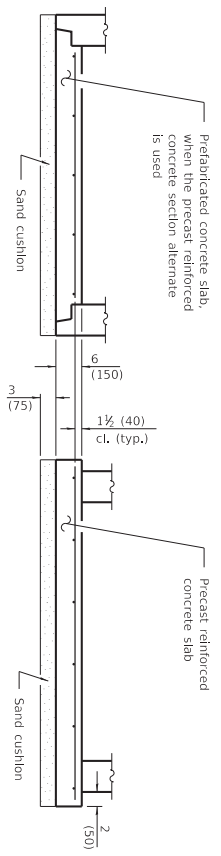
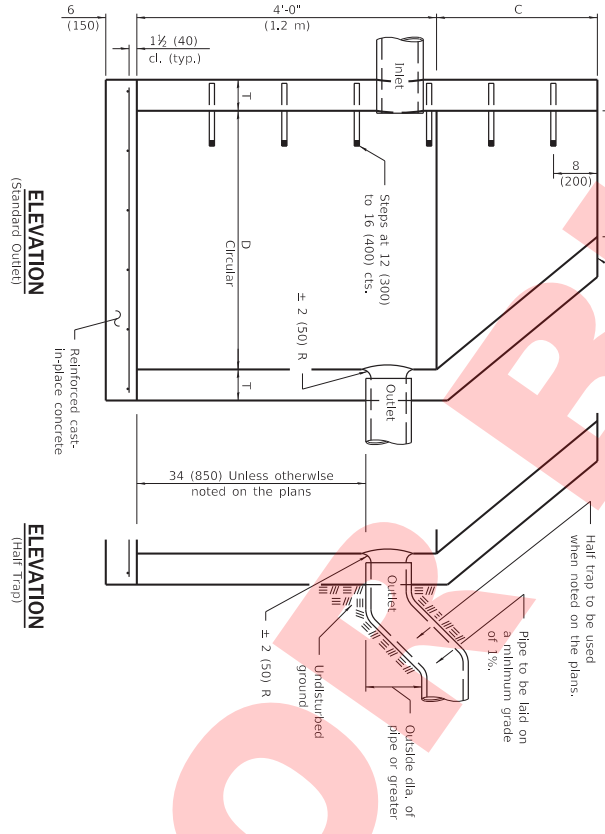

ALTERNATE MATERIALS FOR WALLS	D	C*	T (min.)
Concrete Masonry Unit	4'-0" (1.2 m) 5'-0" (1.5 m)	30 (750) 3'-9" (1.15 m)	5 (125) 5 (125)
Brick Masonry	4'-0" (1.2 m) 5'-0" (1.5 m)	30 (750) 3'-9" (1.15 m)	8 (200) 8 (200)
Precast Reinforced Concrete Section	4'-0" (1.2 m) 5'-0" (1.5 m)	30 (750) 3'-9" (1.15 m)	4 (100) 5 (125)
Cast-in-place Concrete	4'-0" (1.2 m) 5'-0" (1.5 m)	30 (750) 3'-9" (1.15 m)	6 (150) 6 (150)

* For precast reinforced concrete sections, dimension "C" may vary from the dimension given to plus 6 (150).

GENERAL NOTES

Bottom slabs shall be reinforced with a minimum of 0.20 sq. in./ft. (420 sq. mm/m) in both directions with a maximum spacing of 12 (300).
 Bottom slabs may be connected to the riser as determined by the fabricator; however, only a single row of reinforcement around the perimeter may be utilized.
 See Standard 602601 for optional precast reinforced concrete flat slab top.
 See Standard 602701 for details of steps.
 All dimensions are in inches (millimeters) unless otherwise shown.

DATE	REVISIONS
1-1-11	Added "Outside" to half trap note. Detail rein. in slabs.
1-1-09	Revised general notes. Switched units to English (metric).

CATCH BASIN TYPE A
 STANDARD 602001-02

ALTERNATE MATERIALS FOR WALLS	T (min)
Precast Reinforced Concrete Section	3 (75)
Concrete Masonry Unit	5 (125)
Cast-in-Place Concrete	6 (150)
Brick Masonry	8 (200)

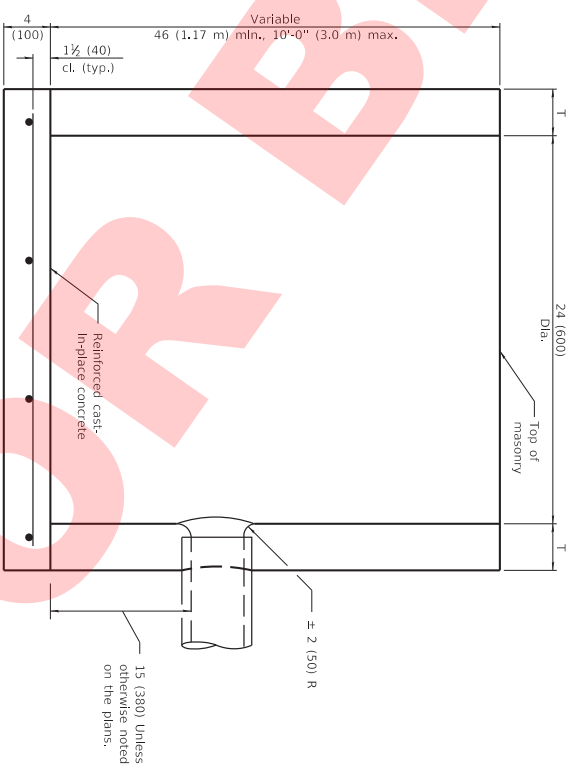

ELEVATION

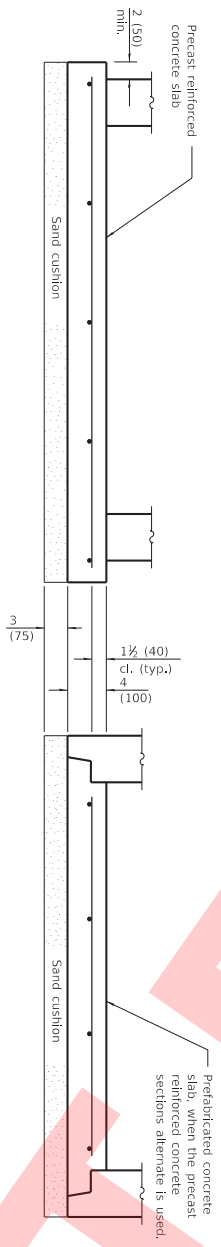

ALTERNATE BOTTOM SLAB

GENERAL NOTES

Bottom slabs shall be reinforced with a minimum of 0.27 sq. in./ft. (570 sq. mm/m) in both directions with a maximum spacing of 9 (230). Bottom slabs may be connected to the riser as determined by the fabricator; however, only a single row of reinforcement around the perimeter may be utilized.

All dimensions are in inches (millimeters) unless otherwise shown.

CATCH BASIN TYPE C

STANDARD 602011-02

Illinois Department of Transportation
 PASSED January 3, 2011
 ENGINEER OF POLICY AND PROCEDURES
 APPROVED January 3, 2011
 ENGINEER OF DESIGN AND ENVIRONMENT

DATE	REVISIONS
1-1-11	Detailed rein. in slabs.
	Added max. limit to height.
	Added general notes.
1-1-09	Switched units to English (metric).

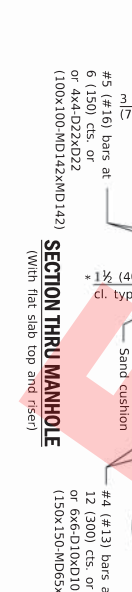
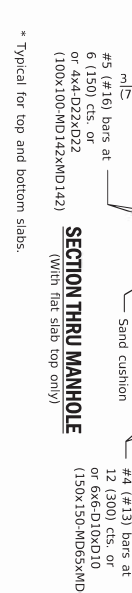
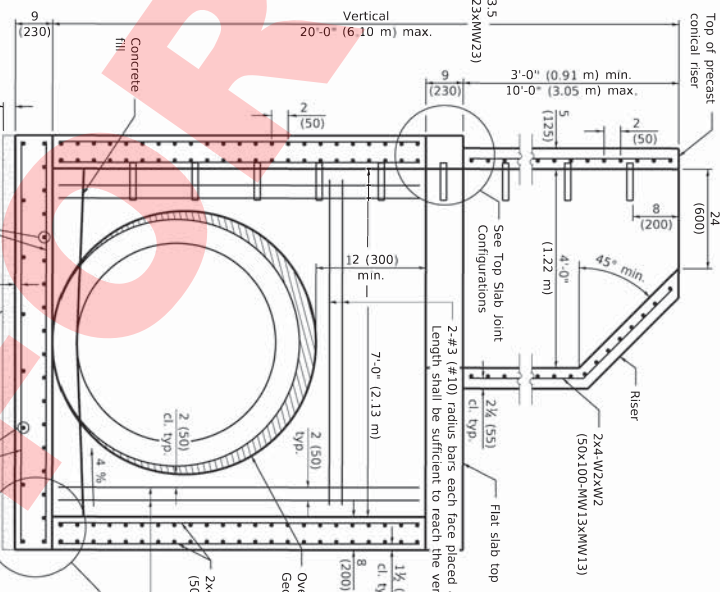
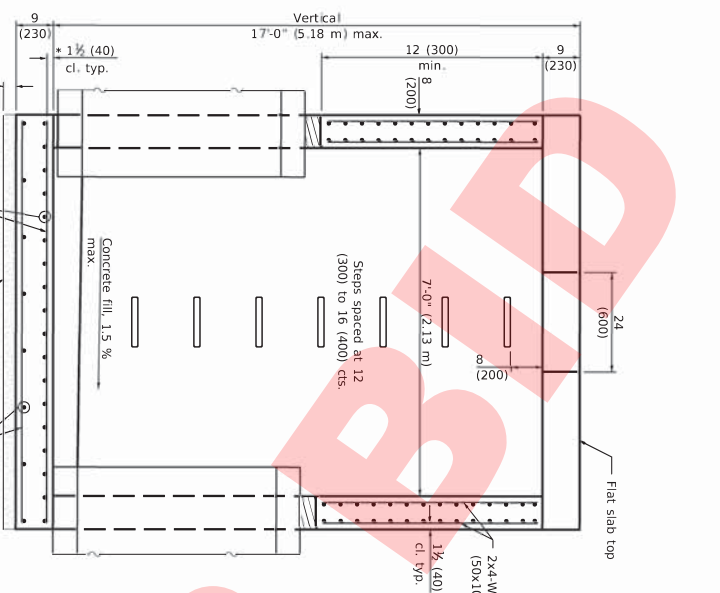

TOP SLAB JOINT CONFIGURATIONS
(Shown at access hole)

1. A minimum of 12 (300) of monolithic reinforced concrete shall be maintained above the fabricated pipe hole.
2. A minimum 12 (300) inside arc length of reinforced concrete, extending vertically from bottom slab to top slab, shall be maintained between the fabricated pipe holes.
3. A maximum of 60 percent of the inside perimeter of the reinforced concrete manhole walls may be removed.
4. Horizontal joints through pipe holes shall be spliced when the remaining column between holes, measured along inside arc length, is less than 24 (600). See detail.
5. The recommended oversized hole is equal to the O.D. of the pipe plus 4 inches.

GEOMETRIC LIMITS

Oversized holes, as necessary for constructability, shall satisfy the following requirements:

BOTTOM SLAB JOINT CONFIGURATIONS

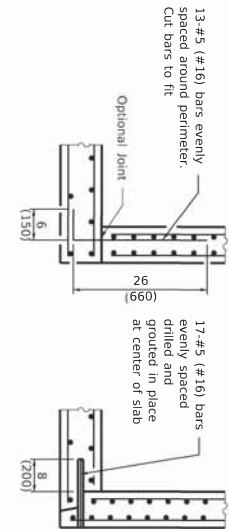
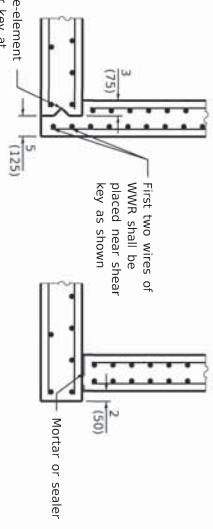

ISSUES	4-1-06
DESIGNED BY	Michael R. Powell
APPROVED BY	Matthew J. Blais
DATE	January 1, 2018
PROJECT	Illinois Department of Transportation

DATE	REVISIONS
1-1-18	Completely revised standard for LRFD. Renamed standard.
4-1-16	Changed terminology to welded wire reinforcement.

PRECAST MANHOLE TYPE A
7' (2.13 m) DIAMETER
(Sheet 1 of 3)

STANDARD 602411-06

See Sheet 3 for General Notes.

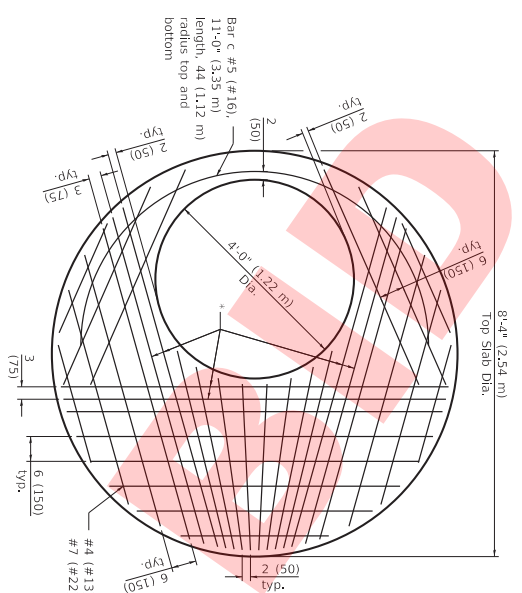

(Showing Layout of Reinforcement Bars)

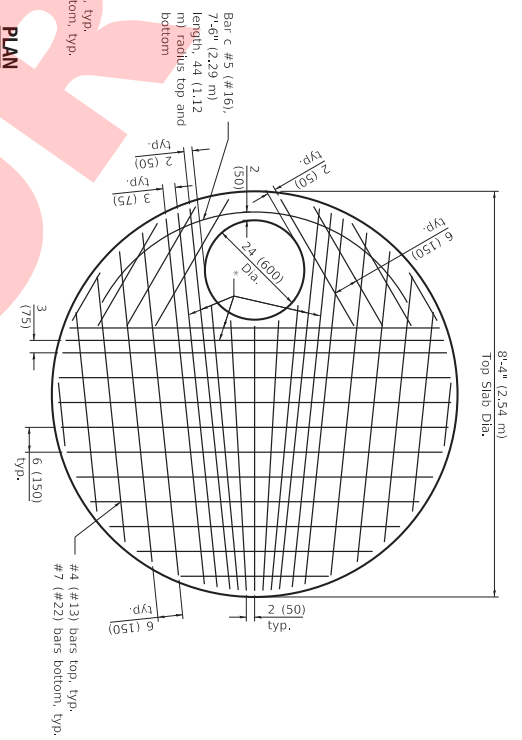

(Showing Layout of Welded Wire Reinforcement)

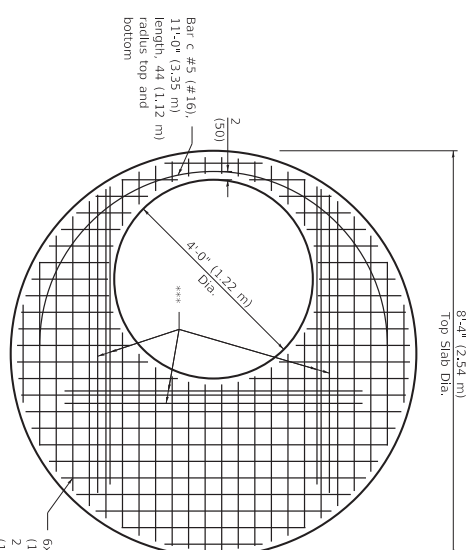

(Showing Layout of Reinforcement Bars)

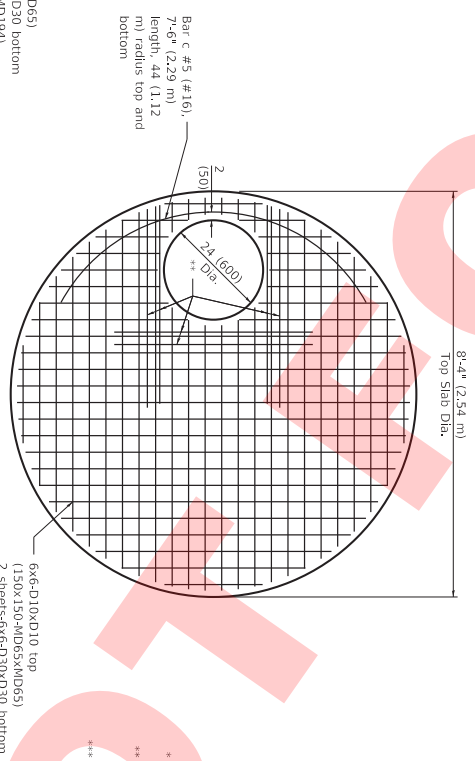

(Showing Layout of Welded Wire Reinforcement)

- * #7 (#22) bars at 3 (75) cts. top and bottom.
- ** #7 (#22) bars at 3 (75) cts. 4'-0" (1.22 m) long top and bottom. Bundle first bar with closest WWR bar to the opening.
- *** #7 (#22) bars at 3 (75) cts. 6'-0" (1.83 m) long top and bottom. Bundle first bar with closest WWR bar to the opening.

Illinois Department of Transportation
 PASSED January 1, 2018
 Michael Reed
 ENGINEER OF POLICE AND PROCEDURES
 APPROVED January 1, 2018
 Matthew N. Bales
 ENGINEER OF DESIGN AND ENVIRONMENT
 ISSUED 4-1-06

PRECAST MANHOLE TYPE A
7' (2.13 m) DIAMETER
 STANDARD 602411-06
 (Sheet 2 of 3)

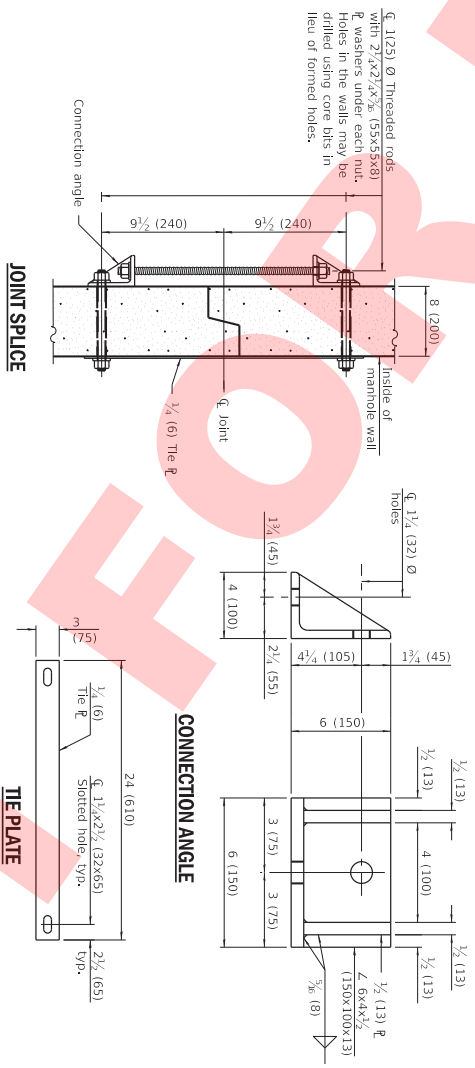

1/2 (13) R Threaded rods with 2 1/4 x 2 1/4 x 3/8 (55x55x8) R washers under each nut. Holes in the walls may be drilled using core bits in lieu of formed holes.

Connection angle

JOINT SPLICE

1/4 (6) The R

Inside of manhole wall

CONNECTION ANGLE

TIE PLATE

24 (610)

2 1/2 (65)

3 (75)

1/2 (6) The R

Slotted hole - typ.

6 (150)

4 3/4 (105)

1 3/4 (45)

1 1/4 (32) diameter holes

3 (75)

6 (150)

1/2 (13) R

4 6x4x3/8 (150x100x13)

1/2 (13)

4 (100)

1/2 (13)

6 (150)

3 (75)

3 (75)

6 (150)

1/2 (13)

1/2 (13)

GENERAL NOTES

Joint configuration and dimensions of flat slab shall match and fit the user joint detail.
 Pipe holes shall be formed to facilitate proper placement of hole reinforcement.
 The manufacturer shall ensure that all precast manhole sections are additionally reinforced where required to resist damage from handling, shipping and installation stresses.
 Lifting holes shall be located in the sections as per the manufacturer's recommendations and grouted prior to backfilling.
 See Standard 602701 for details of manhole steps.
 All dimensions are in inches (millimeters) unless otherwise noted.

PRECAST MANHOLE TYPE A
7' (2.13 m) DIAMETER

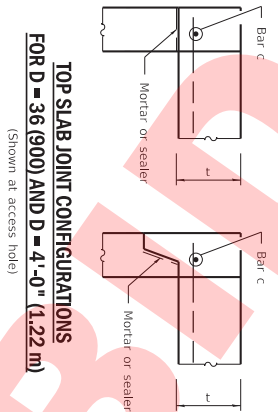

See Top Slab Joint Configurations for D=36 (900) and D=4'-0" (1.22 m)

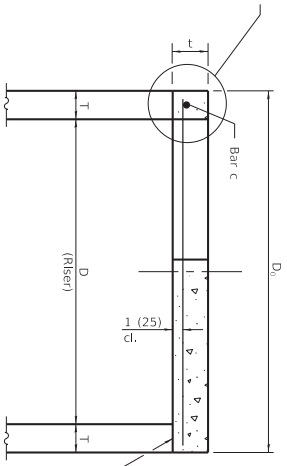

TOP SECTION THRU INLET OR CATCH BASIN FOR D = 36 (900) AND D = 4'-0" (1.22 m)

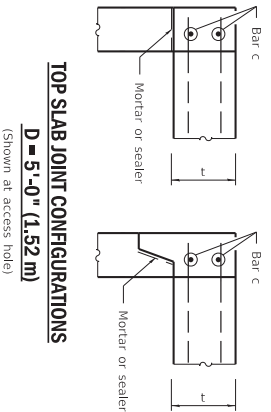

See Top Slab Joint Configurations for D=5'-0" (1.52 m)

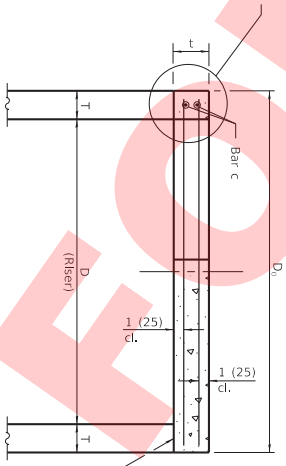

TOP SECTION THRU CATCH BASIN FOR D = 5'-0" (1.52 m)

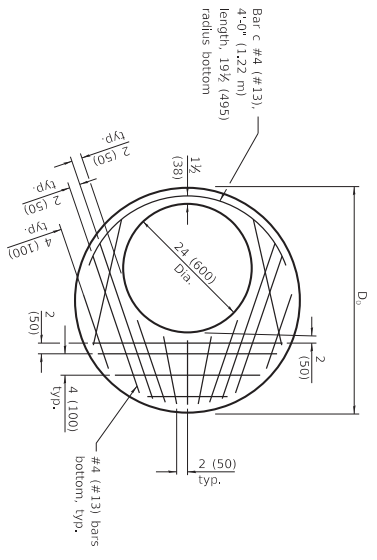

PLAN FOR D = 36 (900)
(Showing Layout of Reinforcement Bars)

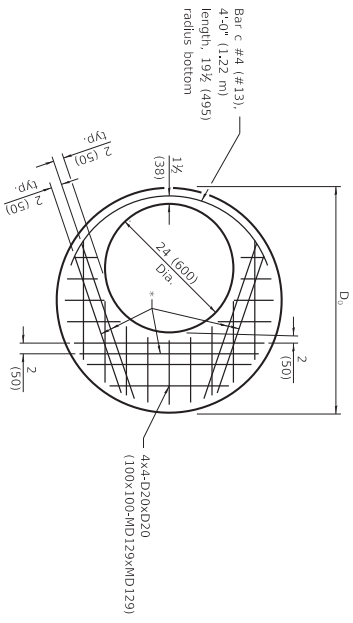

PLAN FOR D = 5'-0" (1.52 m)
(Showing Layout of Welded Wire Reinforcement)

* #4 (#13) bars bottom. Bundle first bar with WWR bar closest to the opening.

GENERAL NOTES

The flat slab top may be used in lieu of the tapered tops shown on Standards 602001, 602016, or 602306 at the option of the Contractor or when field conditions prohibit the use of tapered tops.

Lifting holes shall be located in the sections as per the manufacturer's recommendations and grouted prior to backfilling.

All dimensions are in inches (millimeters) unless otherwise shown.

TABLE

D	T	D ₀ (min.)	t
36 (900)		(150)	6
4'-0" (1.2 m)		(150)	6
5'-0" (1.5 m)		(200)	8
	See applicable Standards	D + 2T	

Illinois Department of Transportation
 PASSED January 1, 2018
 Michael Rowland
 ENGINEER OF FORCE AND PROCEDURES
 APPROVED January 1, 2018
 Matthew N. Bales
 ENGINEER OF DESIGN AND ENVIRONMENT
 ISSUE# 1-1-97

DATE	REVISIONS
1-1-18	Revised for compliance with LRFD.
4-1-16	Changed terminology to "welded wire reinforcement".

PRECAST REINFORCED CONCRETE FLAT SLAB TOP
 STANDARD 602601-05
 (Sheet 1 of 2)

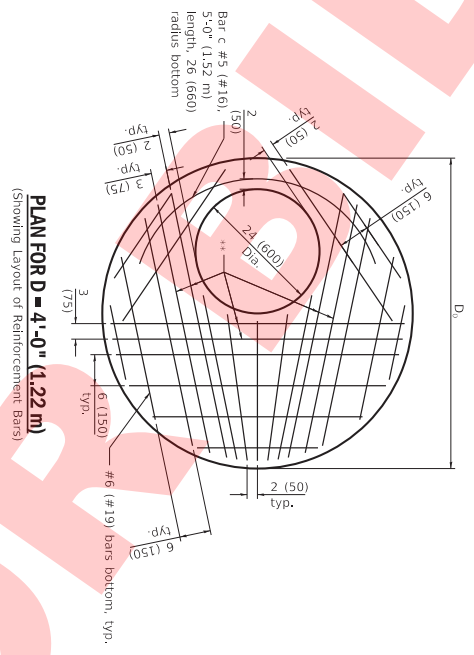

PLAN FOR D = 4'-0" (1.22 m)
(Showing Layout of Reinforcement Bars)

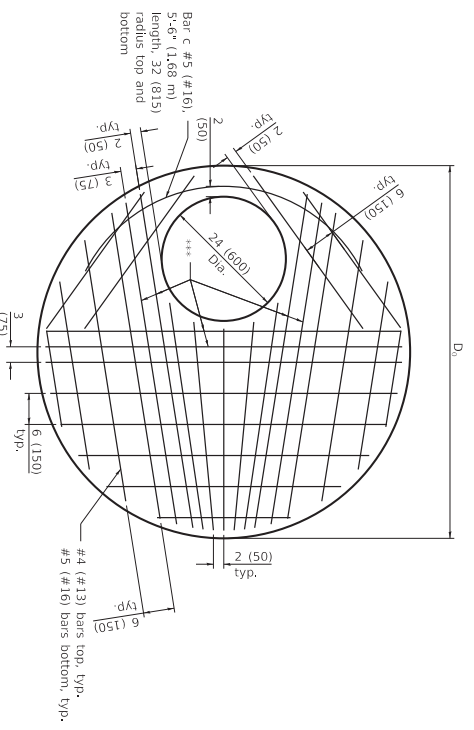

PLAN FOR D = 5'-0" (1.52 m)
(Showing Layout of Reinforcement Bars)

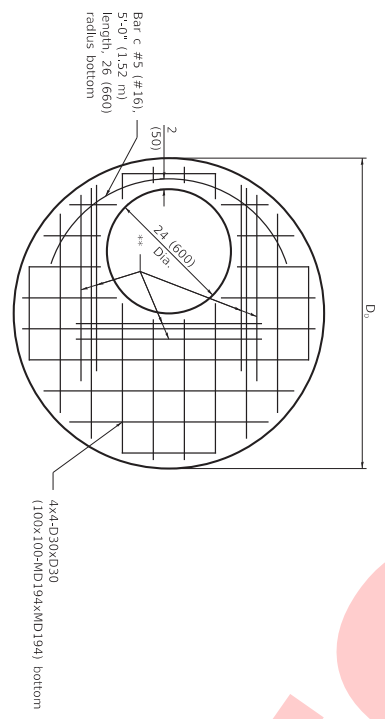

PLAN FOR D = 4'-0" (1.22 m)
(Showing Layout of Welded Wire Reinforcement)

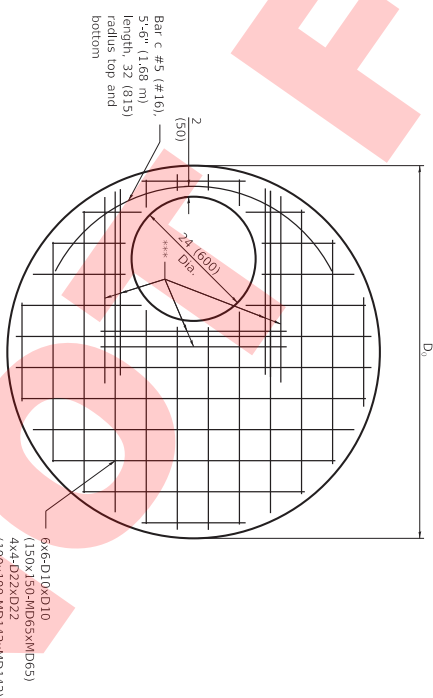

PLAN FOR D = 5'-0" (1.52 m)
(Showing Layout of Welded Wire Reinforcement)

** #5 (#16) bars bottom. For WWR, bundle first bar with WWR bar closest to the opening.

*** #5 (#16) bars top and bottom. For WWR, bundle first bar with WWR bar closest to the opening.

Illinois Department of Transportation
 PASSED: *Michael Rowland* January 1, 2018
 ENGINEER OF POLICY AND PROCEDURES
 APPROVED: *Michael Rowland* January 1, 2018
 ENGINEER OF DESIGN AND ENVIRONMENT
 ISSUE: 1-1-97

PRECAST REINFORCED CONCRETE FLAT SLAB TOP
 STANDARD 602601-05
 (Sheet 2 of 2)

CAST IRON STEPS

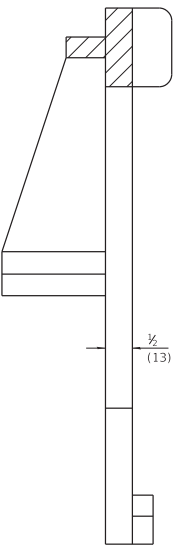
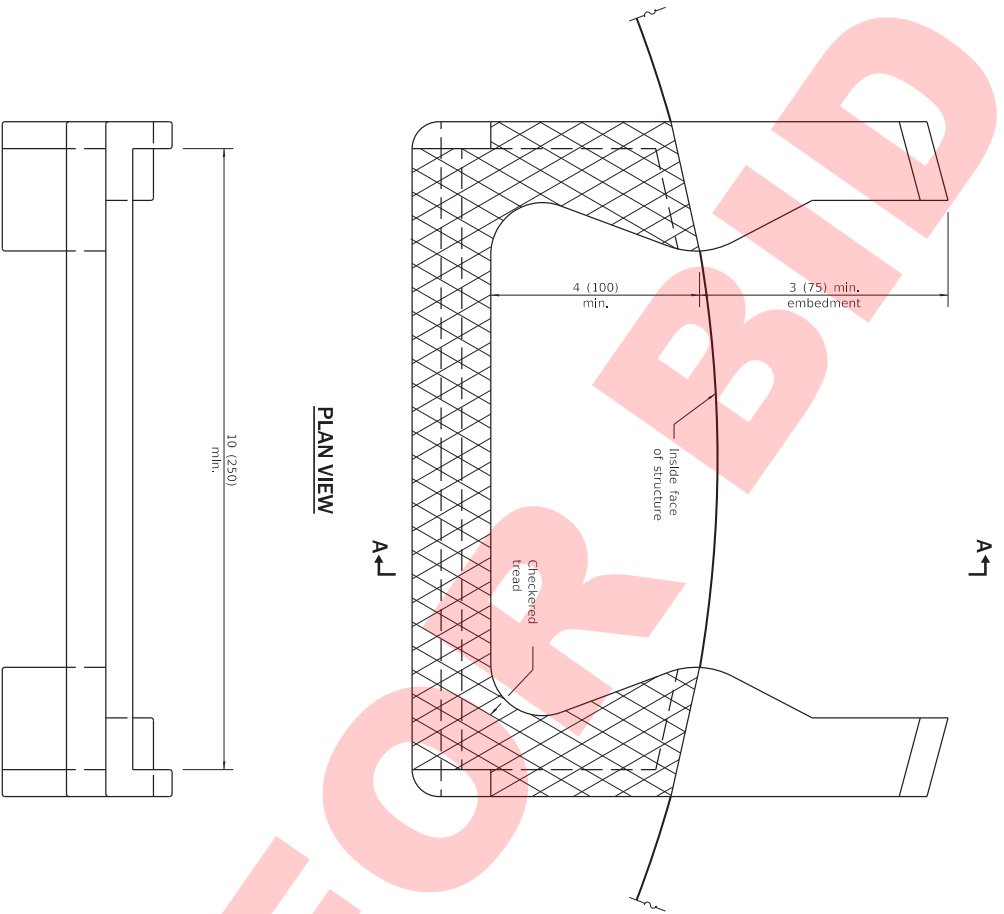

PLAN VIEW

SECTION A-A

ELEVATION VIEW

Illinois Department of Transportation
 PASSED January 1, 2009
 ENGINEER OF POLICY AND PROCEDURES
 APPROVED January 1, 2009
 ENGINEER OF DESIGN AND ENVIRONMENT

DATE	REVISIONS
1-1-09	Switched units to English (metric).
4-1-06	Revised title, drawings, and added plastic steps on Sheet 2.

MANHOLE STEPS
 (Sheet 1 of 2)
STANDARD 602701-02

All dimensions are in inches (millimeters) unless otherwise shown.

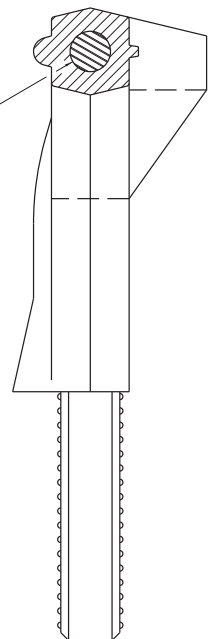
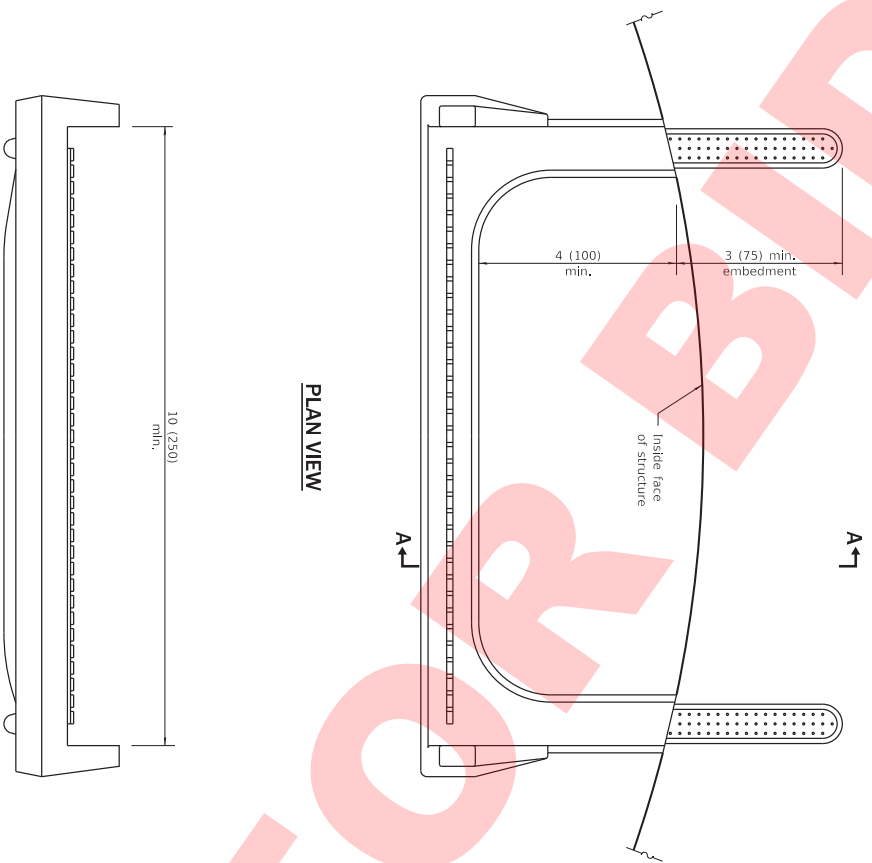

PLAN VIEW

SECTION AA

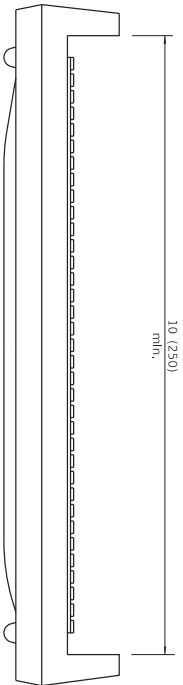

ELEVATION VIEW

Illinois Department of Transportation
PASSED January 1, 2009
ENGINEER OF POLICY AND PROCEDURES
APPROVED *Lee C. Jones* January 1, 2009
ENGINEER OF DESIGN AND ENVIRONMENT
ISSUED 1-1-97

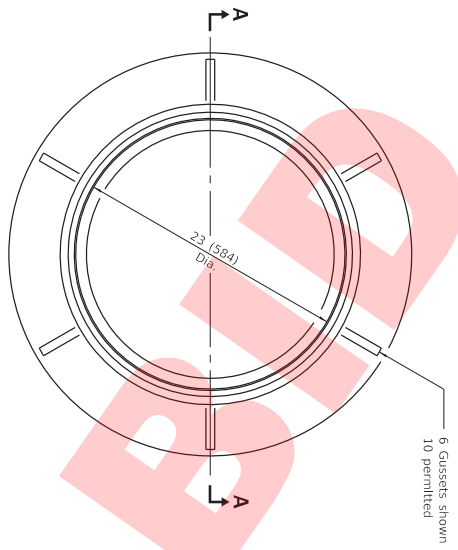

CAST FRAME

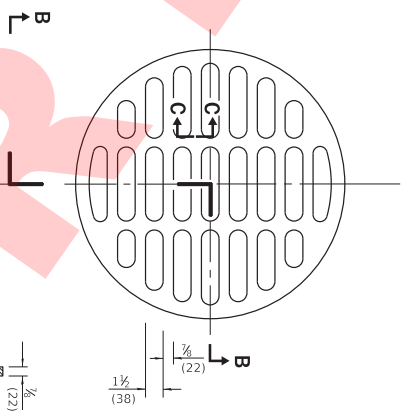

SECTION C-C

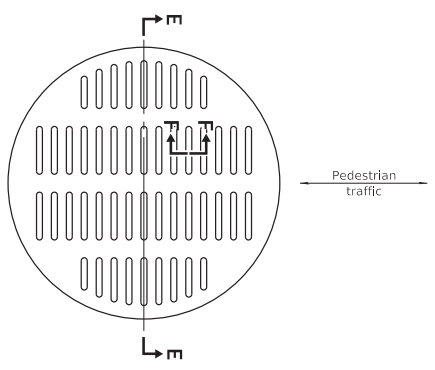
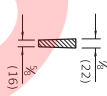

SECTION E-E

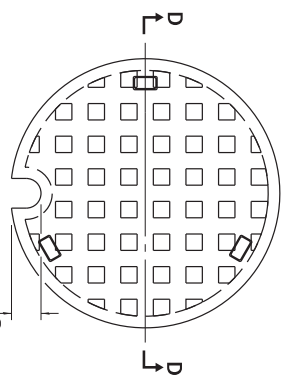
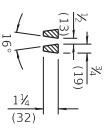

SECTION D-D

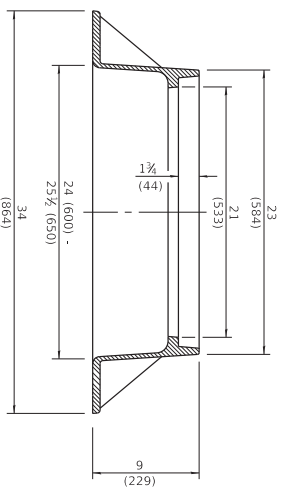
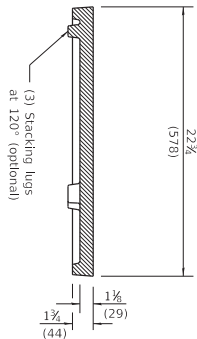

SECTION A-A
Gray Iron

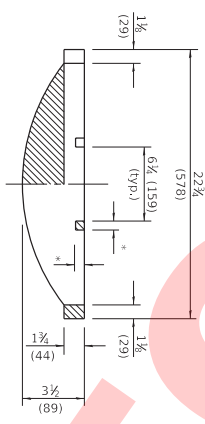

SECTION B-B

CAST OPEN LID

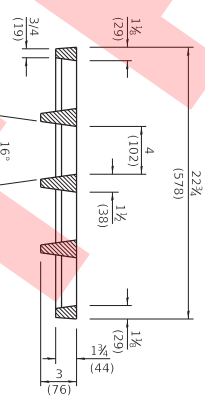

SECTION E-E

**ADA COMPLIANT
CAST OPEN LID**

CAST CLOSED LID
Gray Iron Lid

Illinois Department of Transportation
 PASSED January 1, 2015
 Approved by *Richard Board*
 ENGINEER OF POLICY AND PROCEDURES
 APPROVED January 1, 2015
 ENGINEER OF DESIGN AND ENVIRONMENT
 ISSUE# 1-1-97

DATE	REVISIONS
1-1-15	Revised dimensioning of frame. Added ADA compliant open lid.
1-1-09	Switched units to English (metric).

**FRAME AND LIDS
TYPE 1**

STANDARD 604001-04

All dimensions are in inches (millimeters) unless otherwise shown.

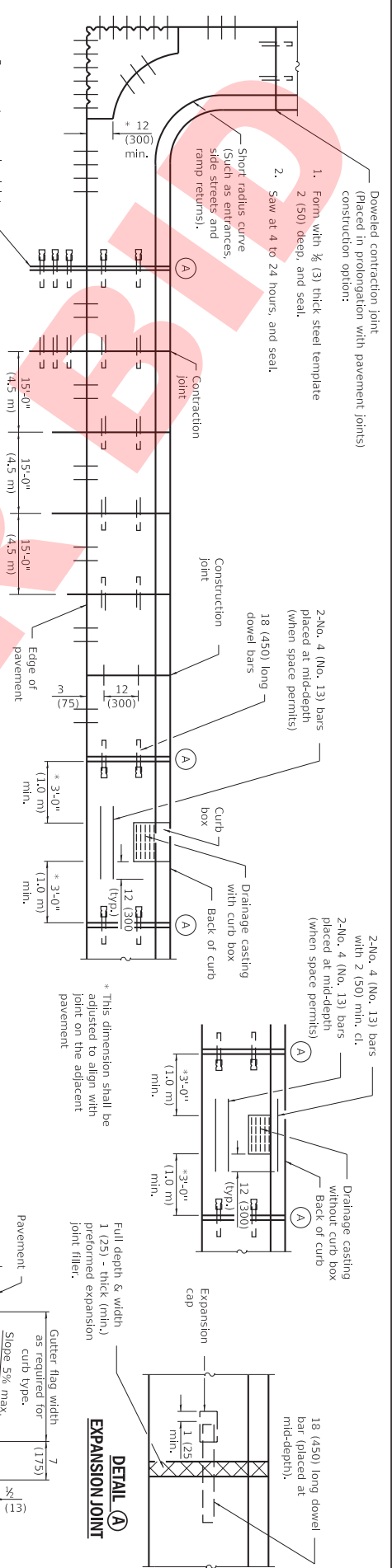

ADJACENT TO PCC PAVEMENT OR PCC BASE COURSE

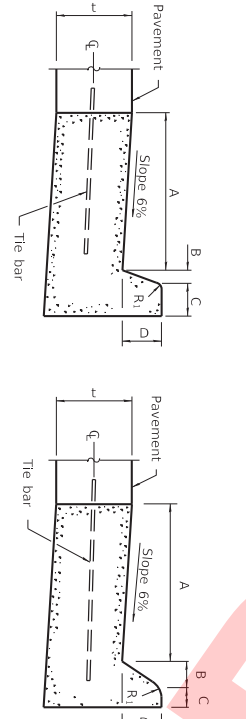

BARRIER CURB

MOUNTABLE CURB

TABLE OF DIMENSIONS
BARRIER CURB

TYPE	A	B	C	D	R ₁
B-6-06*	6	1	6	6	1
(B-15.15)	(150)	(25)	(150)	(150)	(25)
B-6-12	12	1	6	6	1
(B-15.3)	(300)	(25)	(150)	(150)	(25)
B-6-18	18	1	6	6	1
(B-15.45)	(450)	(25)	(150)	(150)	(25)
B-6-24	24	1	6	6	1
(B-15.60)	(600)	(25)	(150)	(150)	(25)
B-9-12	12	2	5	9	1
(B-22.30)	(300)	(50)	(125)	(225)	(25)
B-9-18	18	2	5	9	1
(B-22.45)	(450)	(50)	(125)	(225)	(25)
B-9-24	24	2	5	9	1
(B-22.60)	(600)	(50)	(125)	(225)	(25)

* For corner islands only.

TABLE OF DIMENSIONS
MOUNTABLE CURB

TYPE	A	B	C	D	R ₁	R ₂
M-2-06	6	2	4	2	3	2
(M-5.15)	(150)	(50)	(100)	(50)	(75)	(50)
M-2-12	12	2	4	2	3	2
(M-5.30)	(300)	(50)	(100)	(50)	(75)	(50)
M-4-06	6	4	3	4	3	NA
(M-10.15)	(150)	(100)	(75)	(100)	(75)	NA
M-4-12	12	4	3	4	3	NA
(M-10.30)	(300)	(100)	(75)	(100)	(75)	NA
M-4-18	18	4	3	4	3	NA
(M-10.45)	(450)	(100)	(75)	(100)	(75)	NA
M-4-24	24	4	3	4	3	NA
(M-10.60)	(600)	(100)	(75)	(100)	(75)	NA
M-6-06	6	6	2	6	2	NA
(M-15.15)	(150)	(150)	(50)	(150)	(50)	NA
M-6-12	12	6	2	6	2	NA
(M-15.30)	(300)	(150)	(50)	(150)	(50)	NA
M-6-18	18	6	2	6	2	NA
(M-15.45)	(450)	(150)	(50)	(150)	(50)	NA
M-6-24	24	6	2	6	2	NA
(M-15.60)	(600)	(150)	(50)	(150)	(50)	NA

ADJACENT TO PCC BASE COURSE WITH HMA SURFACING

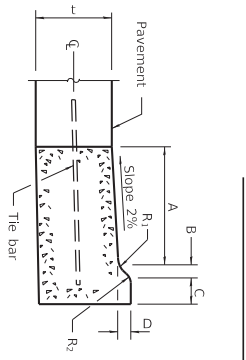

DEPRESSED CURB (TYPICAL)

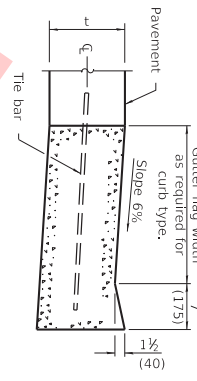

DEPRESSED CURB ADJACENT TO CURB RAMP ACCESSIBLE TO THE DISABLED

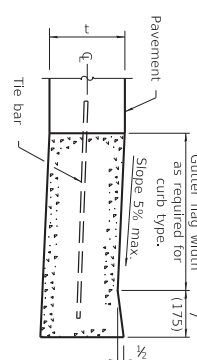

DETAIL (A) EXPANSION JOINT

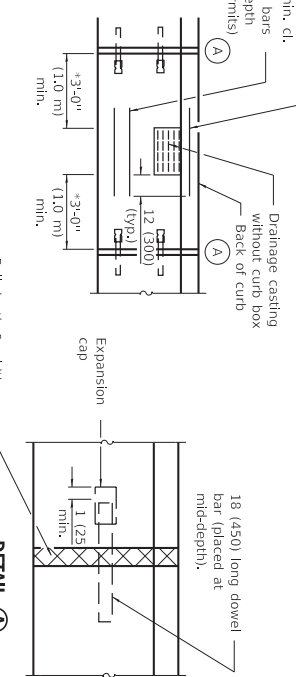

GENERAL NOTES

The bottom slope of combination curb and gutter constructed adjacent to pcc pavement shall be the same slope as the subbase or 6% when subbase is omitted.

t = Thickness of pavement.

Longitudinal joint: the bars shall be No. 6 (No. 19) at 36 (900) centers in accordance with details for longitudinal construction joint shown on Standard 420001.

A minimum clearance of 2 (50) between the end of the tie bar and the back of the curb shall be maintained.

The dowel bars shown in contraction joints will only be required for monolithic construction.

See Standard 606501 for details of corner islands.

All dimensions are in inches (millimeters) unless otherwise shown.

DATE	REVISIONS
1-1-18	Revised General Note for the bar spacing to 36 (900) cts.
1-1-15	Added B-6-06 (B-15.15) barrier curb and gutter to table (corner islands only).

CONCRETE CURB TYPE B AND COMBINATION CONCRETE CURB AND GUTTER
(Sheet 1 of 2)
STANDARD 606001-07

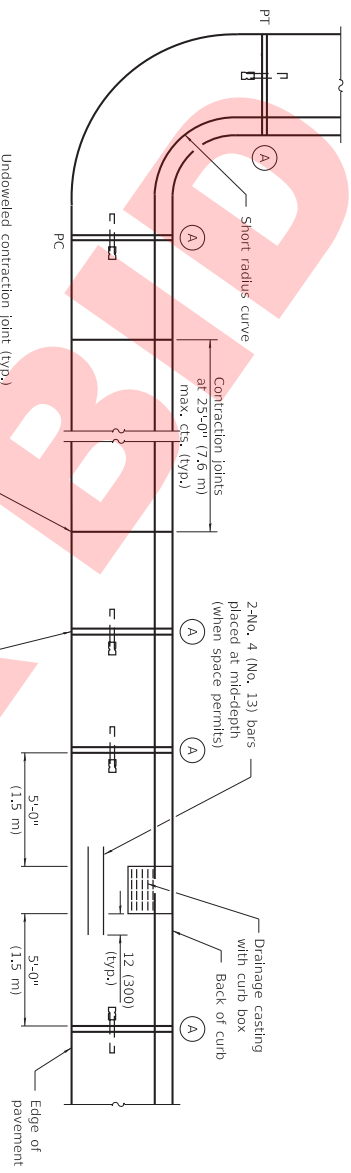

1. Form with $\frac{3}{8}$ (3) thick steel template
2. (50) deep, and seal.
3. Saw 2 (50) deep at 4 to 24 hours, and seal.

Undowled contraction joint (typ.) construction options:

PLAN

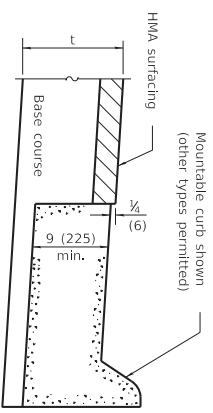
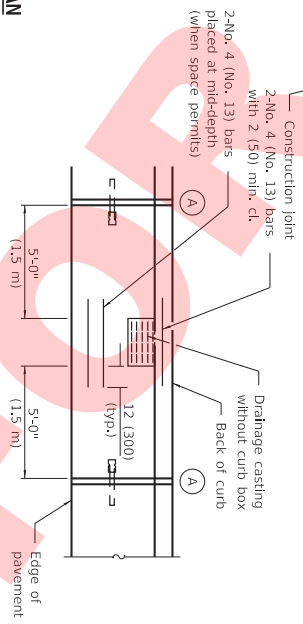

ON DISTURBED SUBGRADE

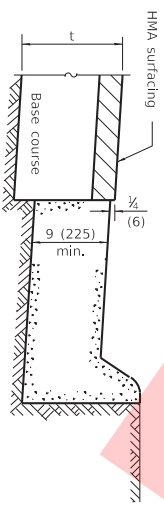

ON UNDISTURBED SUBGRADE

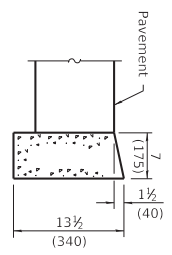

DEPRESSED CURB

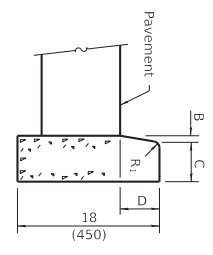

BARRIER CURB

ADJACENT TO FLEXIBLE PAVEMENT

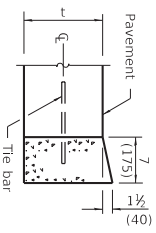

DEPRESSED CURB

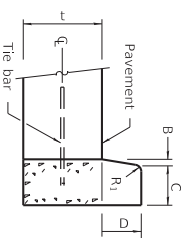

BARRIER CURB

ADJACENT TO PCC PAVEMENT OR PCC BASE COURSE

CONCRETE CURB TYPE B

CONCRETE CURB TYPE B AND COMBINATION CONCRETE CURB AND GUTTER

STANDARD 606001-07

ADJACENT TO FLEXIBLE PAVEMENT

TYPICAL APPLICATIONS

Marking patches
 Field survey
 String line
 Utility operations
 Cleaning up debris on pavement

SYMBOLS

Work area
 Sign on portable or permanent support
 Flagger with traffic control sign

DATE	REVISIONS
1-1-11	Revised flagger sign.
1-1-09	Switched units to English (metric).

**LANE CLOSURE, 2L, 2W,
 SHORT TIME OPERATIONS**

STANDARD 701301-04

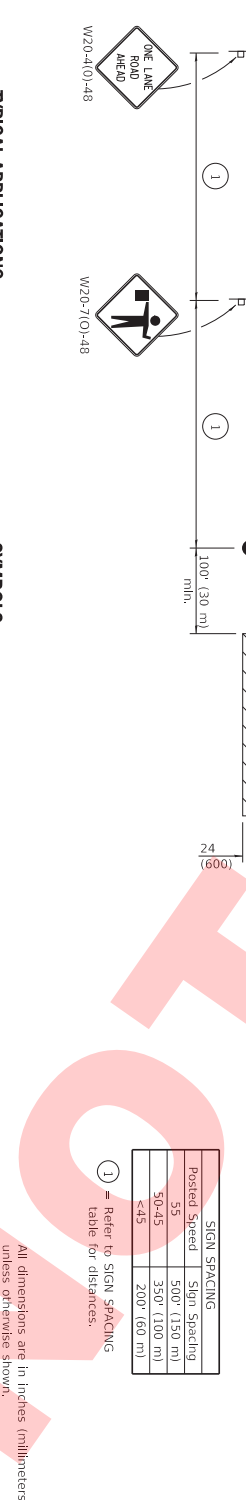

Posted Speed	Sign Spacing
55	500' (150 m)
50-45	350' (100 m)
<45	200' (60 m)

(1) = Refer to SIGN SPACING table for distances.

All dimensions are in inches (millimeters) unless otherwise shown.

For any operation that encroaches in the area between the centerline and a line 24 (600) outside the edge of the pavement for a period in excess of 15 minutes but less than 60 minutes.

For any operation that is more than 24 (600) outside the edge of the pavement for a period of less than 60 minutes.

Vehicle with dual flashers or flashing amber dome light operating.

Vehicle with dual flashers or flashing amber dome light operating.

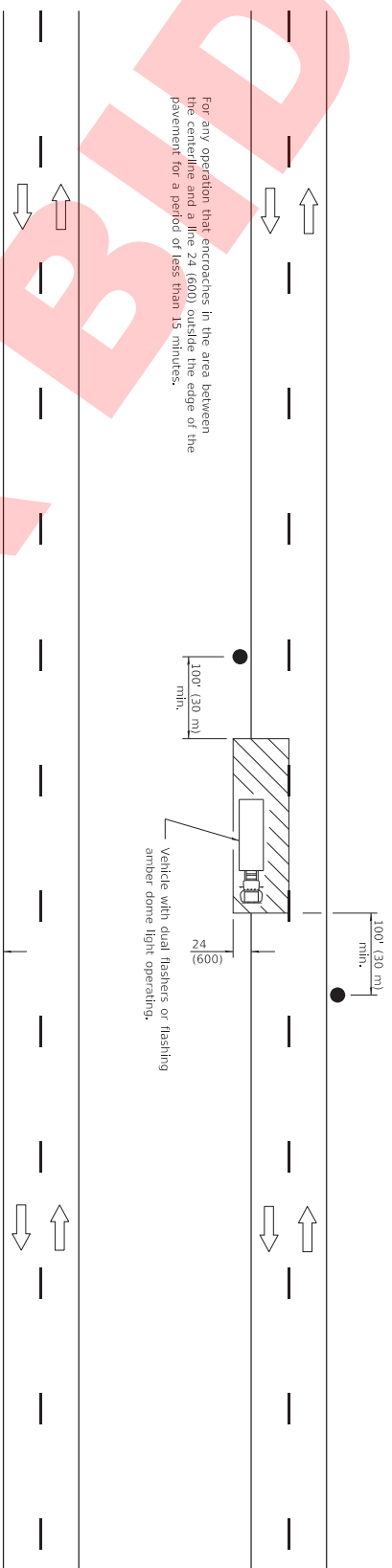

Posted Speed	Sign Spacing
55	500' (150 m)
50-45	350' (100 m)
<45	200' (60 m)

SYMBOLS

- Work area
- Cone, drum or barricade (not required for moving operations)
- Sign on portable or permanent support
- Flagger with traffic control sign
- Barricade or drum with flashing light
- Type III barricade with flashing lights

- 1 Refer to SIGN SPACING TABLE for distances.
- 2 For approved sideroad closures.
- 3 Cones at 25' (8 m) centers for 250' (75 m) additional center. When placed at 50' (15 m) centers, when units or used, the interval between devices may be doubled.
- 4 Cones, drums or barricades at 20' (6 m) centers.

GENERAL NOTES

This Standard is used where at any time, day or night, any vehicle, equipment, workers or their activities on the pavement requiring the closure of one traffic lane in an urban area.
 All dimensions are in inches (millimeters) unless otherwise shown.

DATE	REVISIONS
1-1-11	Revised flagger sign.
1-1-09	Switched units to English (metric).
	Corrected sign No. 5.

**URBAN LANE CLOSURE,
 2L, 2W, UNDIVIDED
 STANDARD 701501-06**

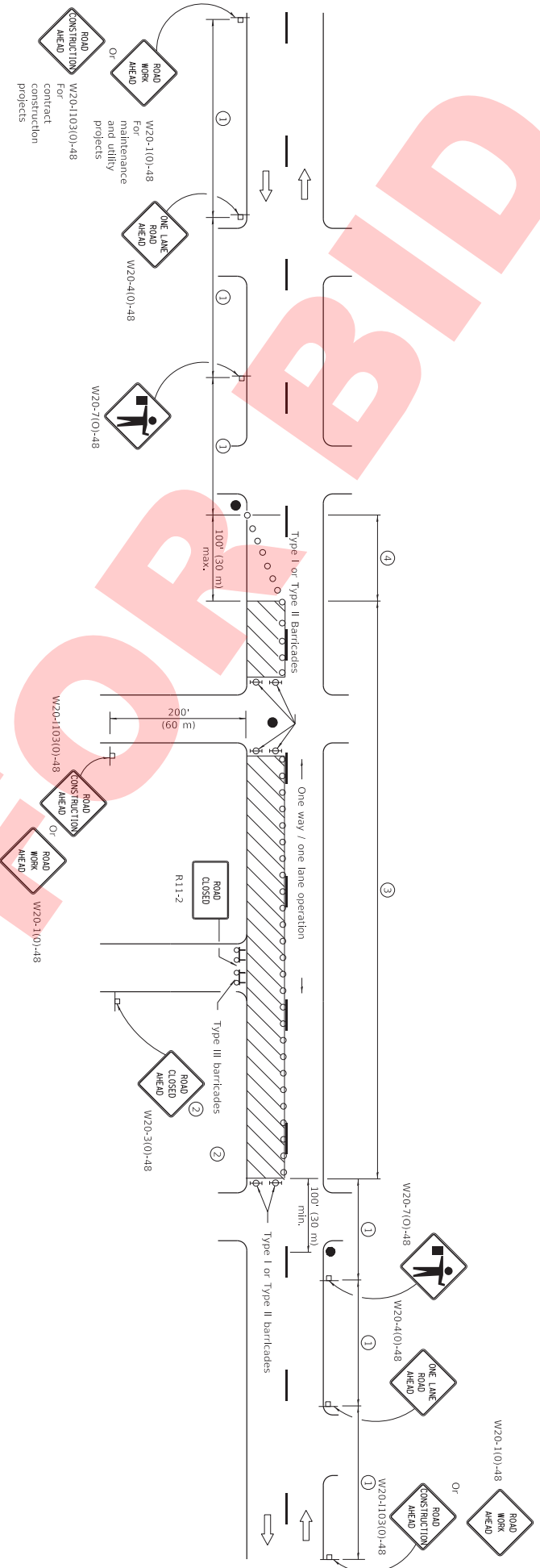

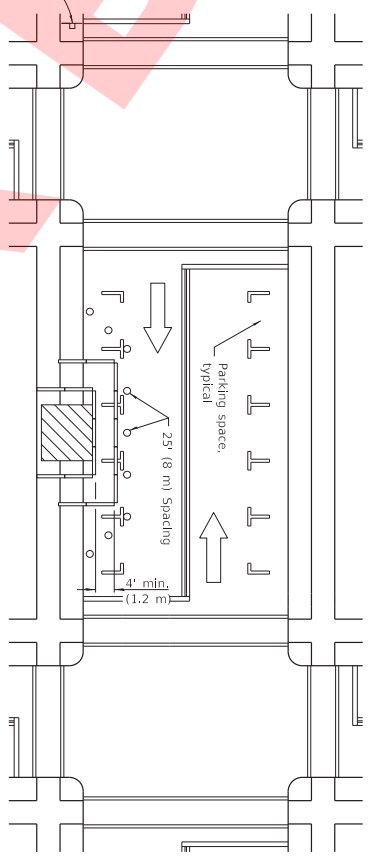

① Onit, whenever duplicated by road work traffic control.

SIDEWALK DIVERSION

GENERAL NOTES

This Standard is used where, at any time, pedestrian traffic must be rerouted due to work being performed.

This Standard must be used in conjunction with other Traffic Control & Protection Standards when roadway traffic is affected.

Temporary facilities shall be detectable and accessible.

The temporary pedestrian facilities shall be provided on the same side of the closed facilities whenever possible.

The SIDEWALK CLOSED / USE OTHER SIDE sign shall be placed at the nearest crosswalk or intersection to each end of the closure. Where the closure occurs at a corner, the signs shall be erected on the corners across the street from the closure. The SIDEWALK CLOSED signs shall be used at the ends of the actual closures.

Type III barricades and R11-2-4830 signs shall be positioned as shown in "ROAD CLOSED TO ALL TRAFFIC" detail on Standard 701901. All dimensions are in inches (millimeters) unless otherwise shown.

SYMBOLS

- Work area
- Sign on portable or permanent support
- Barricade or drum
- Cone, drum or barricade
- Type III barricade
- Detectable pedestrian channelizing barricade

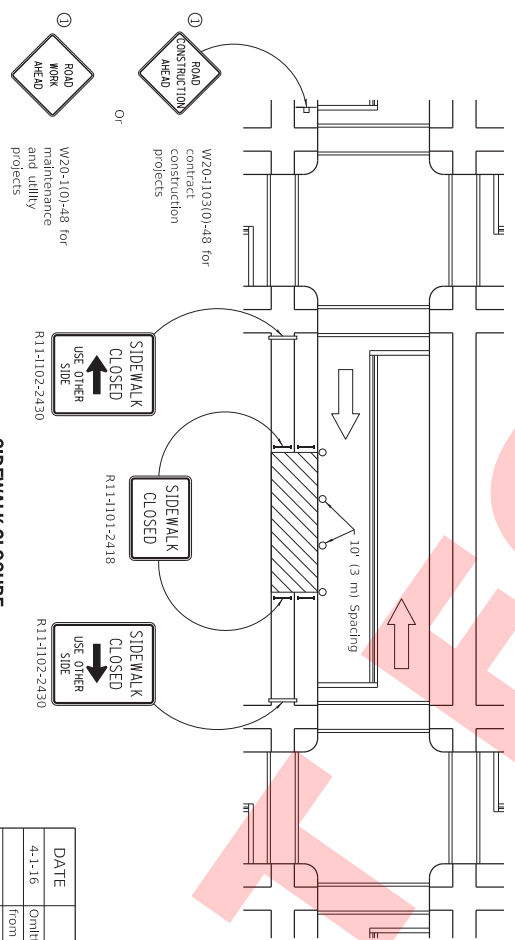

SIDEWALK CLOSURE

DATE	REVISIONS
4-1-16	Omitted orange safety fence
1-1-12	covered in the sid. spec. Added SIDEWALK DIVERSION, Modified appearance of plan views. Renamed Std.

SIDEWALK, CORNER OR CROSSWALK CLOSURE

(Sheet 1 of 2)

STANDARD 701801-06

Illinois Department of Transportation
 PASSED April 1, 2016
 ENGINEER OF SAFETY ENGINEERING
 APPROVED April 1, 2016
 ENGINEER OF DESIGN AND ENVIRONMENT
 ISSUED 1-1-97

CROSSWALK CLOSURE

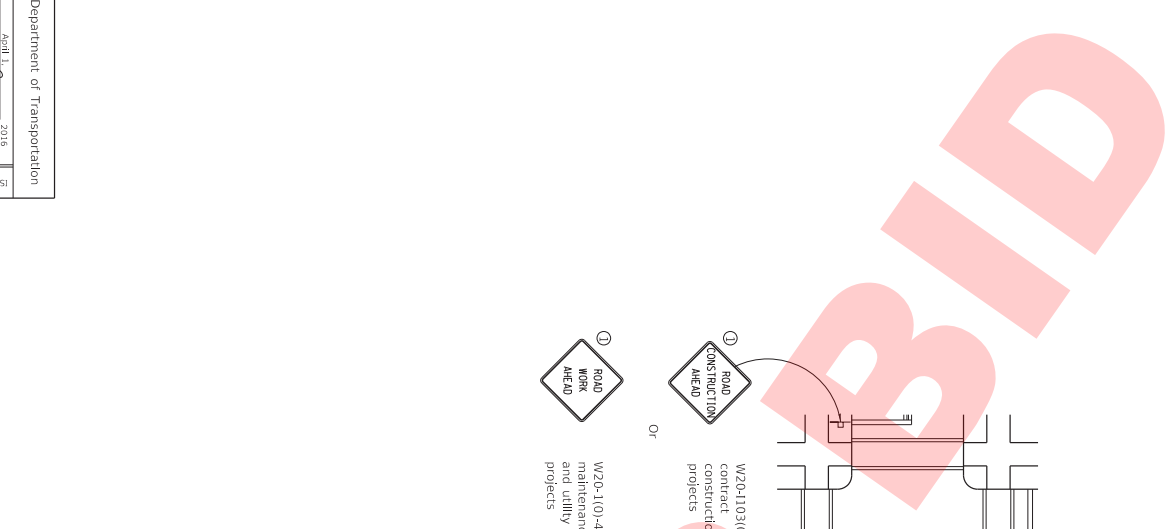
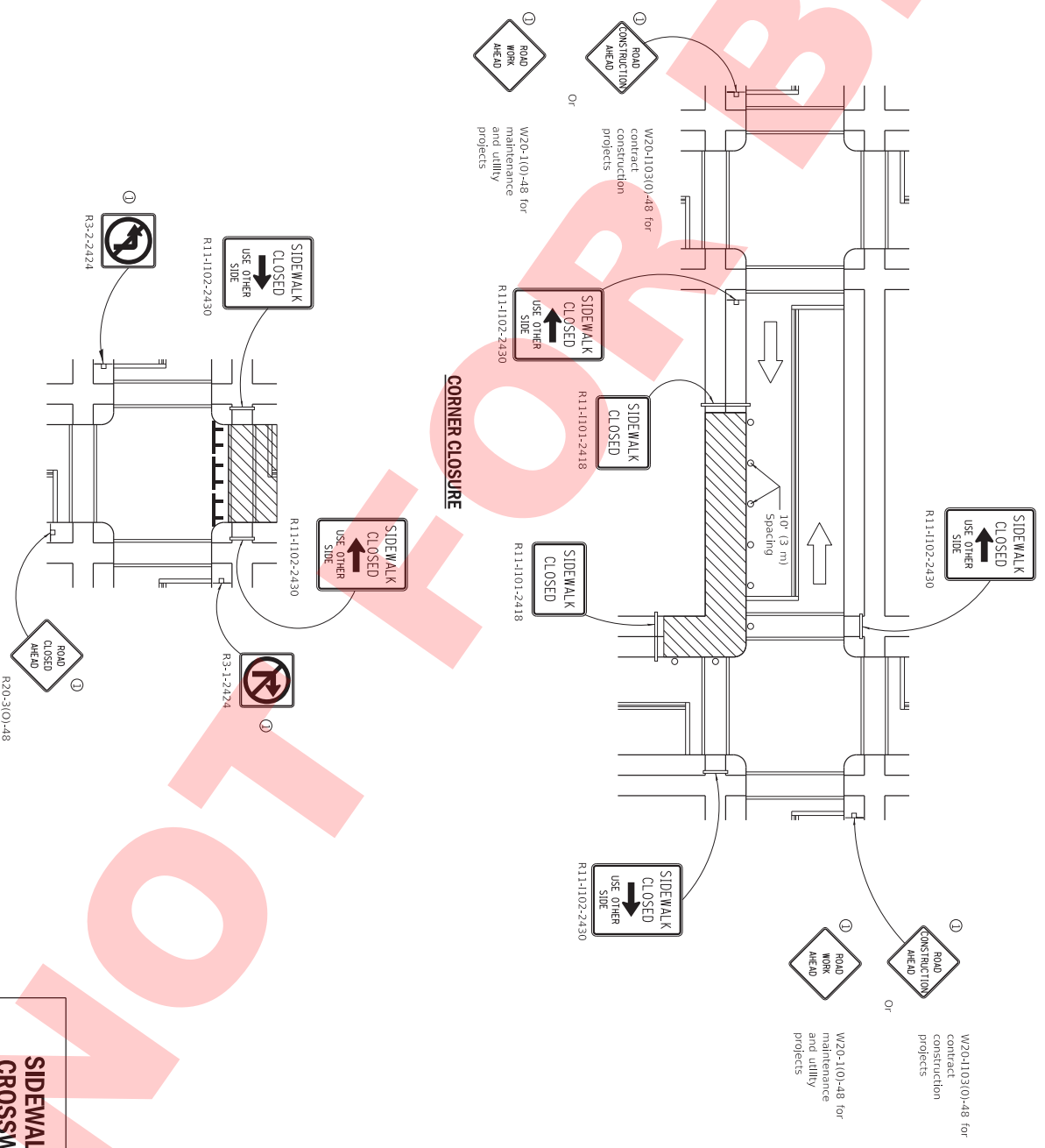

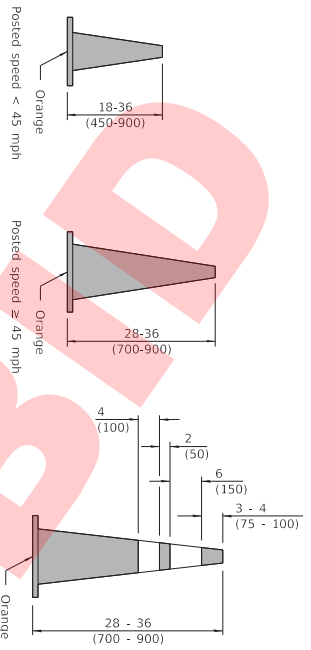

CONE FOR DAYTIME

REFLECTORIZED CONE FOR NIGHTTIME

TUBULAR MARKER

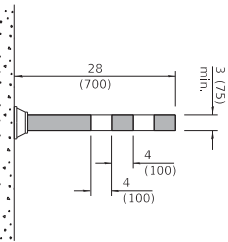

VERTICAL PANEL POST MOUNTED

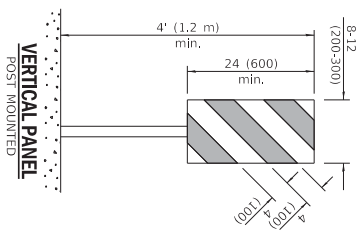

DRUM

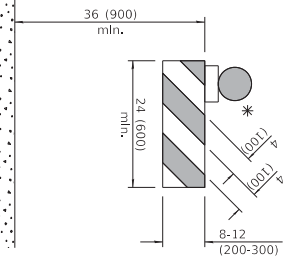
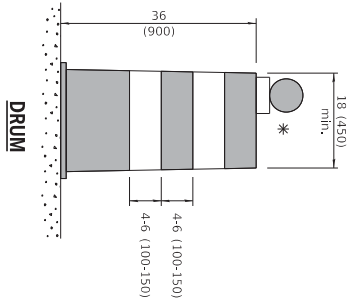

TYPE I BARRICADE

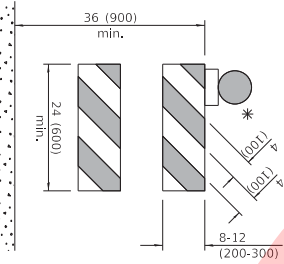

TYPE II BARRICADE

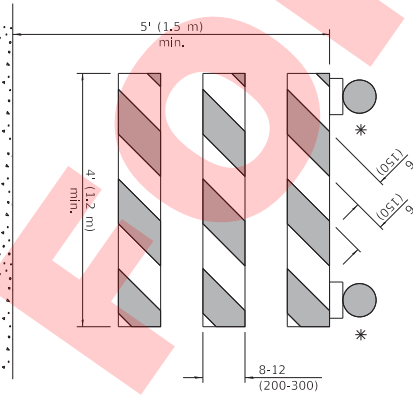

TYPE III BARRICADE

DIRECTION INDICATOR BARRICADE

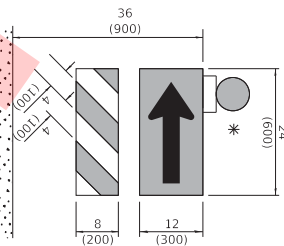

VERTICAL BARRICADE

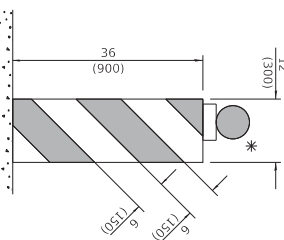

Illinois Department of Transportation
 PASSED January 1, 2018
 APPROVED January 1, 2018
 ENGINEER OF OPERATIONS
 ENGINEER OF DESIGN AND ENVIRONMENT

ISSUED 1-1-97
 2018
 1-1-17
 1-1-18

DETECTABLE PEDESTRIAN CHANNELIZING BARRICADE

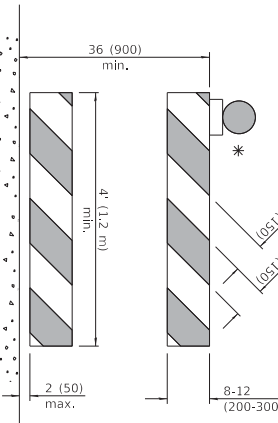

* Warning lights (if required)

DATE	REVISIONS	TRAFFIC CONTROL DEVICES
1-1-18	Revised END WORK ZONE SPEED LIMIT sign from orange to white background.	STANDARD 701901-07 (Sheet 1 of 3)
1-1-17	Changed FLEXIBLE DELINEATOR to TUBULAR MARKER.	

GENERAL NOTES
 All heights shown shall be measured above the pavement surface.
 All dimensions are in inches (millimeters) unless otherwise shown.

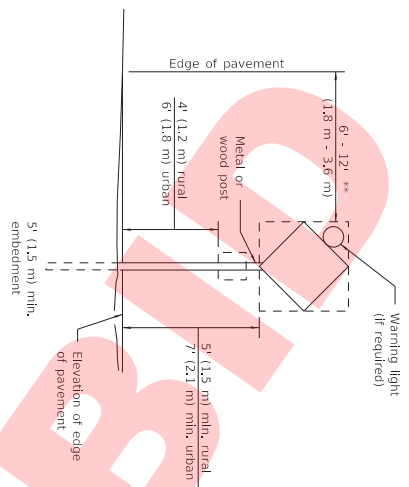

POST MOUNTED SIGNS
 ** When curb or paved shoulder are present this dimension shall be 24 (600) to the face of curb or 6' (1.8 m) to the outside edge of the paved shoulder.

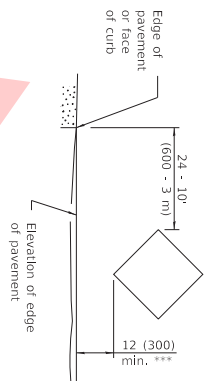

SIGNS ON TEMPORARY SUPPORTS
 *** When work operations exceed four days, this dimension shall be 5' (1.5 m) min. If located behind other devices, the height shall be sufficient to be seen completely above the devices.

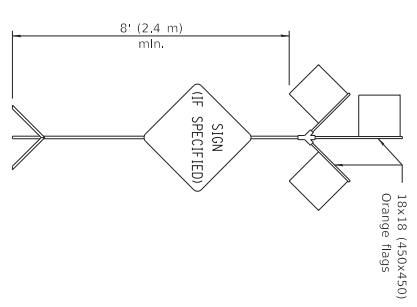

HIGH LEVEL WARNING DEVICE

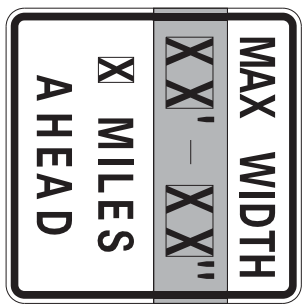

WIDTH RESTRICTION SIGN
 XX'-XX" width and X miles are variable.

WI12-103-4848

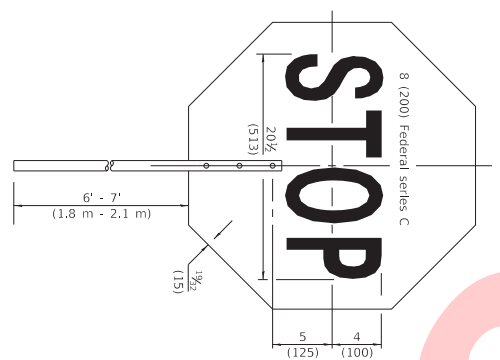

FRONT SIDE

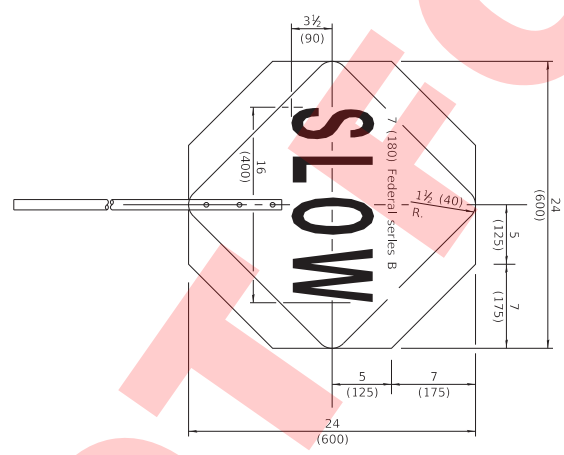

REVERSE SIDE

FLAGGER TRAFFIC CONTROL SIGN

Illinois Department of Transportation
 PASSED January 1, 2018
 APPROVED *John M. [Signature]* January 1, 2018
 ENGINEER OF OPERATIONS
 APPROVED *Matthew [Signature]* January 1, 2018
 ENGINEER OF DESIGN AND ENVIRONMENT
 ISSUED 1-1-97

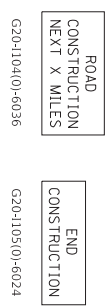

This signing is required for all projects 2 miles (3200 m) or more in length.
 ROAD CONSTRUCTION NEXT X MILES sign shall be placed 500' (150 m) in advance of project limits.
 END CONSTRUCTION sign shall be erected at the end of the job unless another job is within 2 miles (3200 m).
 Dual sign displays shall be utilized on multi-lane highways.

WORK LIMIT SIGNING

WORK ZONE	W2-1-115(0)-3618
SPEED LIMIT	R2-1-1-3648
PHOTO ENFORCED	R10-1-108p-3618 ****
SXXX FINE MINIMUM	R2-1-108p-3618

Sign assembly as shown on Standards or as allowed by District Operations.



This sign shall be used when the above sign assembly is used.

HIGHWAY CONSTRUCTION SPEED ZONE SIGNS

**** R10-1-108p shall only be used along roadways under the jurisdiction of the State.

TRAFFIC CONTROL DEVICES

STANDARD 701901-07 (Sheet 2 of 3)

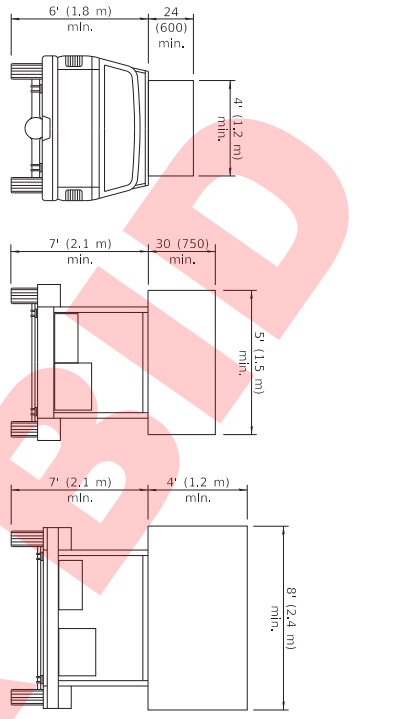

ARROW BOARDS

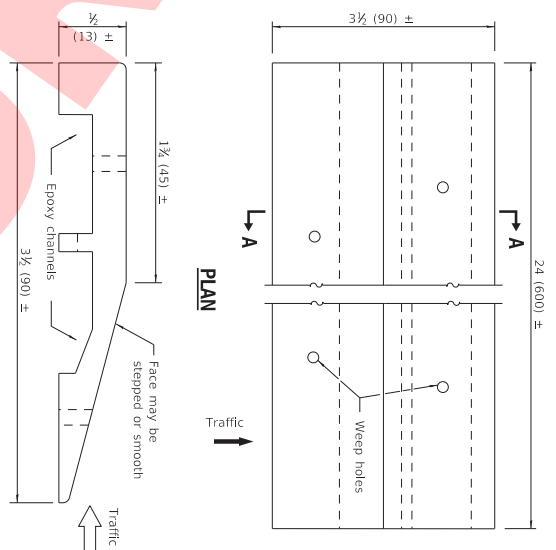

TYPICAL INSTALLATION

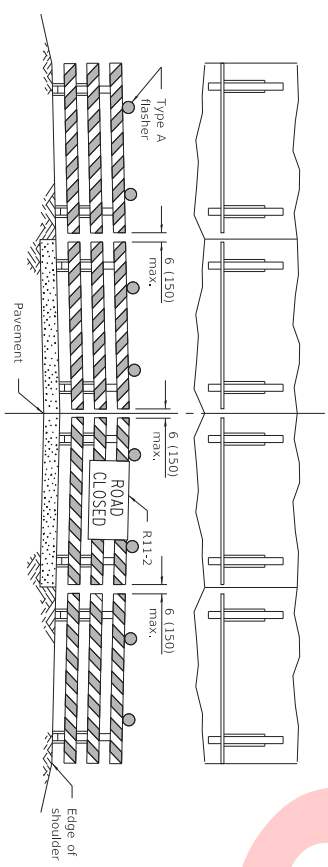
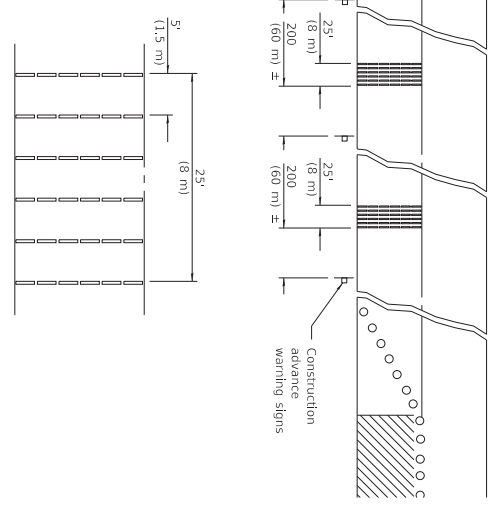

ReflectORIZED striping may be omitted on the back side of the barricades. If a Type III barricade with an attached sign panel which meets NCHRP 350 is not available, the sign may be mounted on an NCHRP 350 temporary sign support directly in front of the barricade.

TYPICAL APPLICATIONS OF TYPE III BARRICADES CLOSING A ROAD

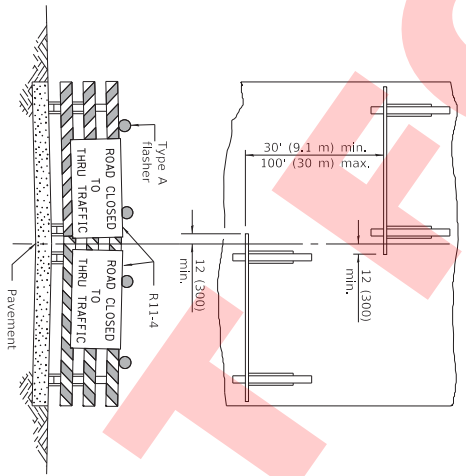

ReflectORIZED striping shall appear on both sides of the barricades. If a Type III barricade with an attached sign panel which meets NCHRP 350 is not available, the signs may be mounted on NCHRP 350 temporary sign supports directly in front of the barricade.

TRAFFIC CONTROL DEVICES

STANDARD 701901-07

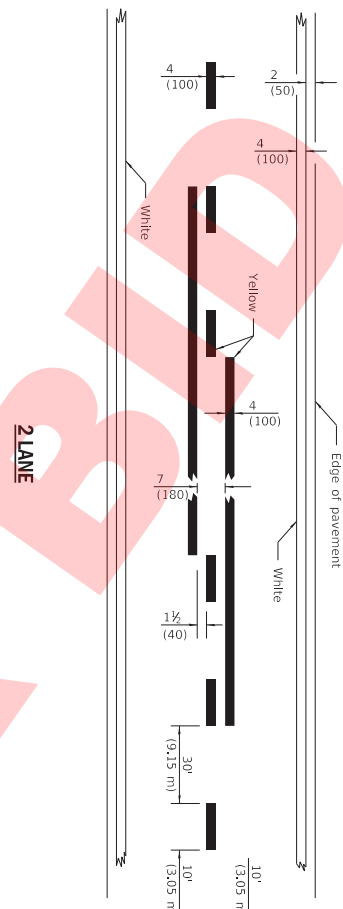

LANE AND EDGE LINES

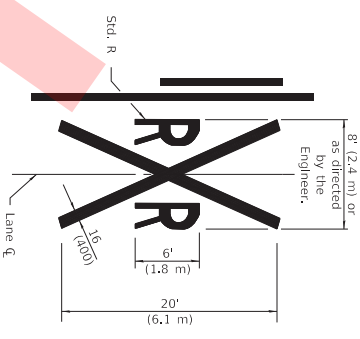
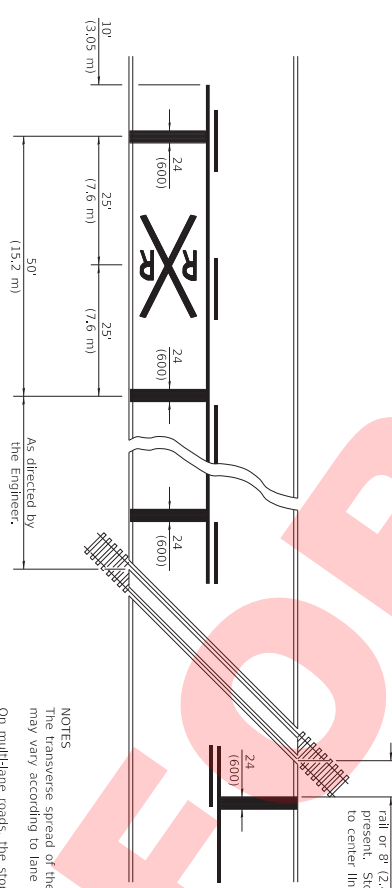
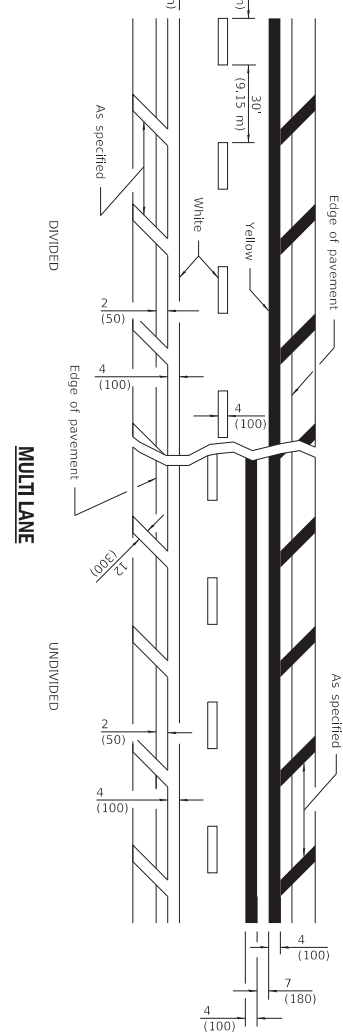

NOTES

The transverse spread of the 'xx' may vary according to lane width.

On multi-lane roads, the stop lines shall extend across all approach lanes and separate RRX symbols shall be placed adjacent to each other in each lane.

When the pavement marking symbol is used, a portion of the symbol should be located directly adjacent to the Advance Warning Sign (W10-1) as placed by Table 2c-4, Condition B of the MUTCD.

PAVEMENT MARKINGS AT RAILROAD-HIGHWAY GRADE CROSSING

Illinois Department of Transportation

ISSUED 1-1-97

PASSED January 1, 2015

ENGINEER OF OPERATIONS

APPROVED January 1, 2015

ENGINEER OF DESIGN AND ENVIRONMENT

DATE	REVISIONS
1-1-15	Added symbols. Revised bike symbol. Revised note for stop line at RR crossing.
1-1-14	Added bike symbol. Renamed 'LANE DROP ARROW' detail to 'LANE-REDUCTION ARROW'.

TYPICAL PAVEMENT MARKINGS

(Sheet 1 of 3)

STANDARD 780001-05

All dimensions are in inches (millimeters) unless otherwise shown.

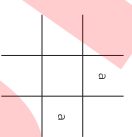
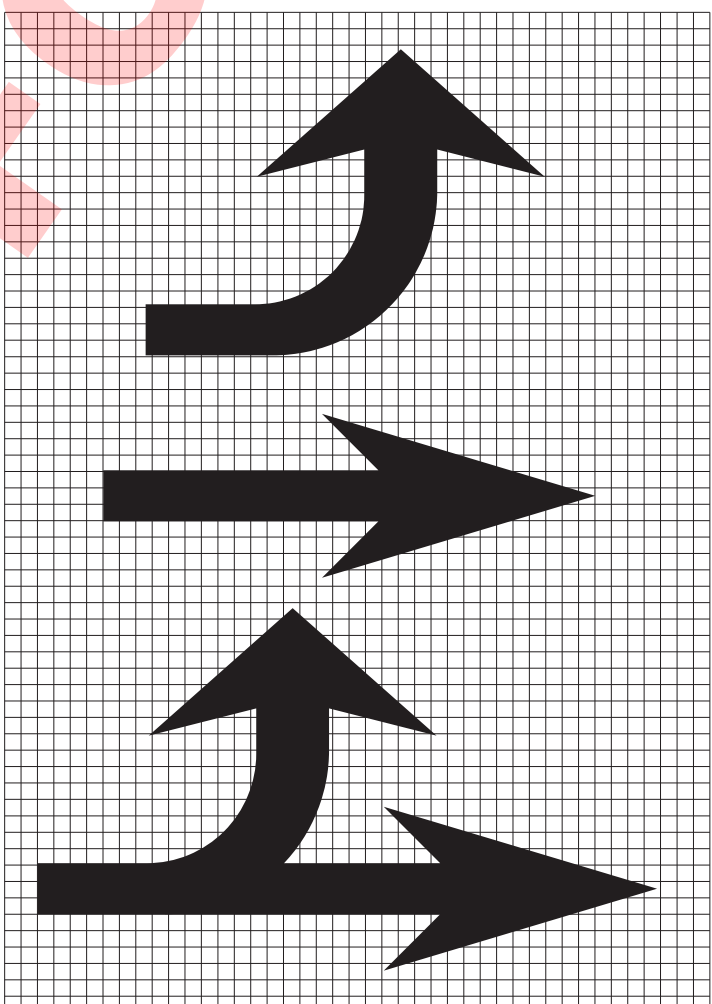
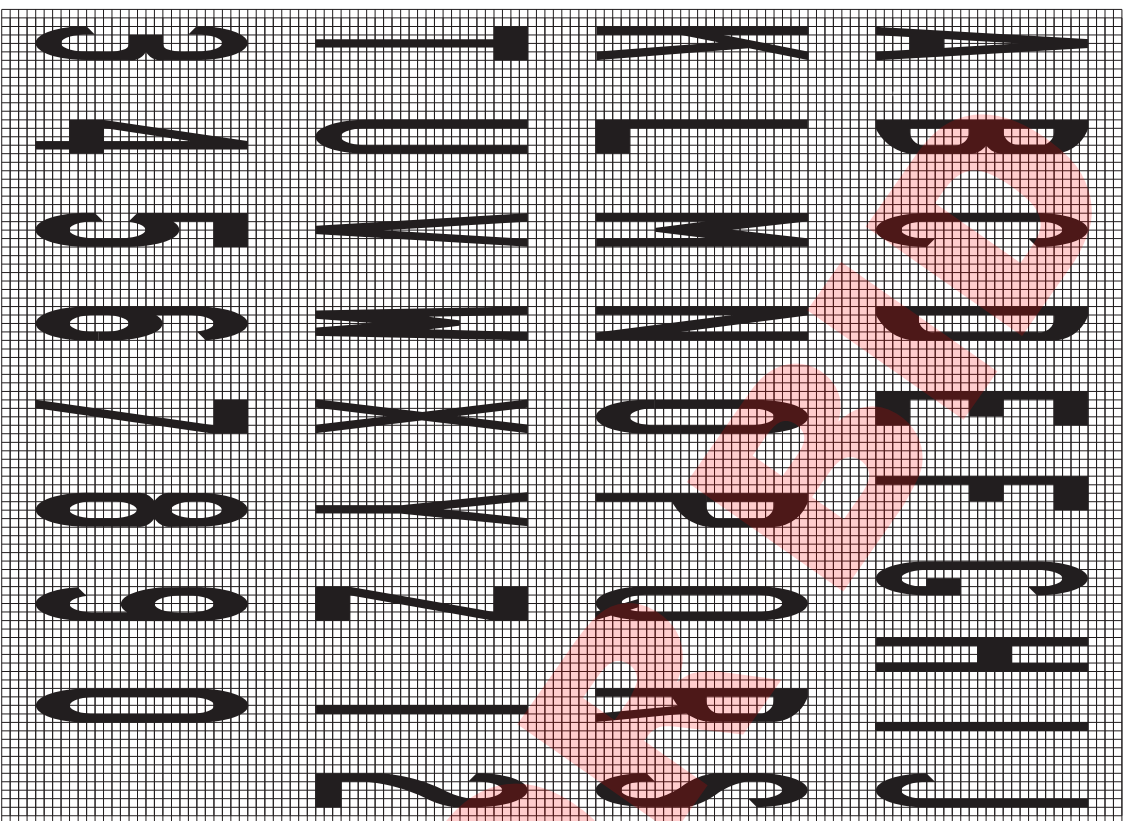

The space between adjacent letters or numerals should be approximately 3 (75) for 6' (1.8 m) legend and 4 (100) for 8' (2.4 m) legend.

Legend Height	Arrow Size	a
6' (1.8 m)	Small	2.9 (74)
8' (2.4 m)	Large	3.8 (96)

LETTER AND ARROW GRID SCALE

Illinois Department of Transportation
 PASSED January 1, 2015
 APPROVED January 1, 2015
 ENGINEER OF OPERATIONS
 ENGINEER OF DESIGN AND ENVIRONMENT

ISSUED 1-1-97

TYPICAL PAVEMENT MARKINGS
 STANDARD 780001-05
 (Sheet 2 of 3)

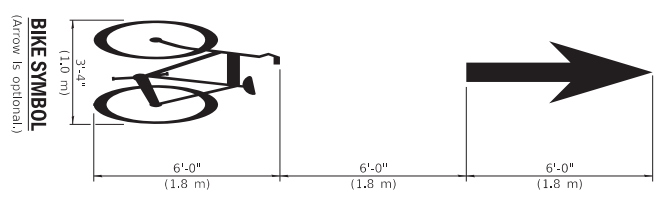
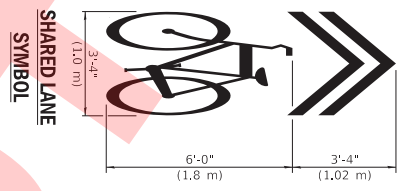
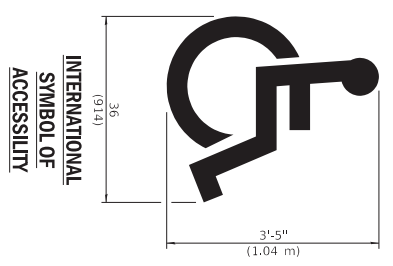
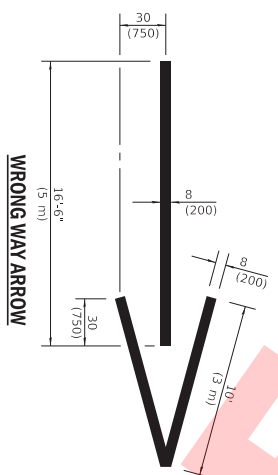
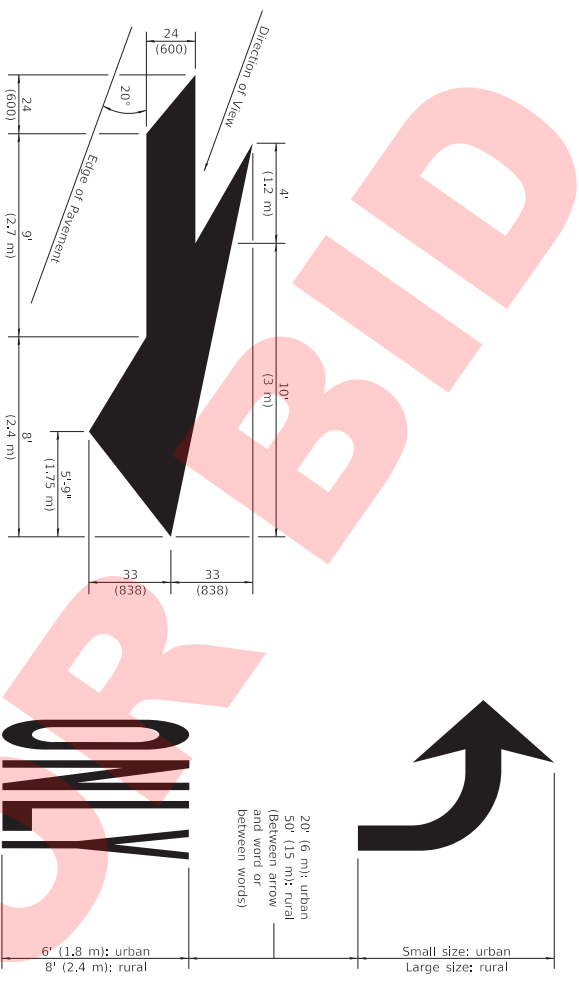

NOT FOR BID

**SECOND AVENUE SEWER SEPARATION
VILLAGE OF VILLA PARK**

APPENDIX A

COMMUNITY DEVELOPMENT BLOCK GRANT (CDBG) FORMS

NOT FOR BID

NOT FOR BID

FEDERAL REQUIREMENTS



THIS BOOKLET IS BEING PROVIDED AS PART OF THE BID MANUAL FOR THIS PROJECT BECAUSE FEDERAL LABOR STANDARDS AND PREVAILING WAGE RATES WILL APPLY TO THIS PROJECT.

THIS BOOKLET CONTAINS:

- Required Contract Provisions for HUD Funded Capital projects in DuPage County, IllinoisPage 1
 - Executive Order 11246Page 13
 - HUD Federal Labor Standards ProvisionsPage 21
- HUD required general contractor and sub-contractor formsPage 26

Samples and instructions for required contractor forms to be filled out, signed, and turned in by all labor providers, including:

 - Ownership FormPage 27
 - Letter to the Office of Federal Contract Compliance LaborPage 28
 - Labor Relations AgreementPage 29
 - Apprenticeship Policy Recognition FormPage 31
 - Section 3 FormsPage 32
 - Certified Payroll and Statement of CompliancePage 39
- A copy of the latest Davis Bacon Federal Wage determination for wage rates in DuPage CountyPage 47

Supplied through the DuPage
Community Development Commission
421 N. County Farm Road
Wheaton, IL 60187

**REQUIRED CONTRACT PROVISIONS FOR HUD FUNDED
CAPITAL PROJECTS IN DUPAGE COUNTY, ILLINOIS**

TABLE OF CONTENTS

I. Application..... 2

II. Equal Opportunity Provisions..... 2

III. Executive Order 11246 (Executive Order 11246 [Applicable to contractors/subcontractors exceeding \$10,000]) 3

IV. Notice of Requirement for Affirmative Action to Ensure Equal Employment Opportunity (Executive Order 11246 – Applicable to contractor/subcontracts exceeding \$10,000) 4

V. Standard Federal Equal Employment Opportunity Construction

Contract Specifications (Executive Order 1246) 5

 A. As Used in these specifications 5

 B. “Minority” Includes 5

 C. Subcontracts..... 5

 D. Equal Employment Opportunity Documentation 6

 E. Voluntary Associations 8

 F. Civil Rights Act of 1964..... 9

 G. Section 109 of the Housing and Community Development Act of 1974 9

 H. “Section 3” Compliance in the Provision of Training, Employment and Business Opportunities..... 9

VI. Contract Work Hours and Safety Standards 10

 A. Overtime Requirements..... 11

 B. Violation and Liability for Unpaid Wages and Liquidated Damages..... 11

 C. Withholding for Unpaid Wages and Liquidated Damages 11

 D. Subcontract 11

 E. Contractor’s Responsibility 11

VII. Safety 11

VIII. False Statements Concerning Projects 11

IX. Implementation of Clean Air Act..... 12

X. Labor Standards 12

I. APPLICATION

- A. These *Required Contract Provisions* shall apply to all work performed on the contract by the Contractor with his own organization and with the assistance of workmen under his immediate superintendence and to all work performed on the contract by piece work, station work or by subcontract.
- B. The Contractor shall insert in each of his subcontracts all of the stipulations contained in these *Required Contract Provisions* and also a clause requiring his Subcontractors to include these *Required Contract Provisions* in any lower tier subcontracts which they may enter into, together with a clause requiring the inclusion of these provisions in any further subcontracts that may in turn be made. The *Required Contract Provisions* shall in no instance be incorporated by reference.
- C. A breach of any of the stipulations contained in these *Required Contract Provisions* may be grounds for termination of the contract.
- D. A breach of the following clauses may also be grounds for debarment as provided in 29 CFR, Part 5.6.
- E. All Bidders must sign the CDC Conditions and submit them with their complete bid package. This form is found in the Bid Specifications Manual.
- F. All bidders and their subcontractor shall be eligible for award of a federally assisted or insured contract. Should any subcontractor be found ineligible after award of a contract, its contract shall be terminated and the matter referred to the Department of Labor for its action.

II. EQUAL OPPORTUNITY PROVISIONS

A. *Equal Opportunity Clause*

Except as otherwise provided, DuPage County requires the inclusion of the following language as a condition of any grant, contract, loan insurance or guarantee involving federally assisted construction which is not exempt from the requirements of equal opportunity. The subgrantee hereby agrees that it will incorporate or cause to be incorporated into any contract for construction work, or modification thereof, as defined in the regulations of the Secretary of Labor at 41 CFR, Part 60, which is paid for in whole or in part with funds obtained from the Federal Government or borrowed on the credit of the Federal Government pursuant to a grant, contract, loan insurance or guarantee or undertaken pursuant to any Federal program involving such grant, contract, loan, insurance or guarantee, the following opportunity Clause:

B. **Activities and Contracts Not Subject to Executive Order 11246, As Amended** (Applicable to federally assisted construction contracts and related subcontracts \$10,000 and under).

During the performance of this contract, the Contractor agrees as follows,

“The Contractor shall not discriminate against any employee or applicant for employment because of race, color religion, sex or national origin. The Contractor shall take affirmative action to ensure that the applicants for employment are employed, and that employees are treated during employment, without regard to their race, color, religion, sex, or national origin.

Such action shall include, but not be limited to, the following; employment, upgrading, demotion or transfer; recruitment or recruitment advertising, layoff or termination; rates of pay or other forms of compensation and selection for training including apprenticeship. The Contractor shall post in conspicuous places, available to employees and applicants for employment, notices to be provided by the DuPage County Community Development Specialist setting forth the provisions of this nondiscrimination clause. The contractor shall state that all qualified applicants will receive consideration for employment without regard to race, color, religion, sex or national origin”.

Contractors shall incorporate foregoing requirements in all subcontracts.

III. EXECUTIVE ORDER 11246 - Equal Employment Opportunity

Contracts/Subcontracts above \$10,000 Section 202 Equal Opportunity Clause

The complete Executive Order 11246 is included in this Federal Requirements booklet.

A. During the performance of this contract, the Contractor agrees as follows,

“The Contractor will not discriminate against any employee or applicant for employment because of race, color, religion, sex or national origin. The Contractor will take affirmative action to ensure that applicants are employed, and employees are treated during employment, without regard to their race, color, religion, sex or national origin. Such action shall include but not be limited to the following: employment, upgrading, demotion or transfer, recruitment or recruitment advertising, layoff or termination, rates of pay or other forms of compensation and selection for training, including apprenticeship. The Contractor agrees to post in conspicuous places, available to employees and applicants for employment, notices to be provided setting forth the provisions of this nondiscrimination clause”.

B. The Contractor will, in all solicitations or advertisements for employees placed by or on behalf of the Contractor, state that all qualified applicants will receive consideration for employment without regard to race, color, religion, sex or national origin.

C. The Contractor will send to each labor union or representative of workers with which he has a collective bargaining agreement or other contract or understanding, a notice to be provided by the Contract Compliance Officer advising the said labor union or worker’s representatives of the contractor’s commitment under this section, and shall post copies of the notice in conspicuous places available to employees and applicants for employment.

D. The Contractor will comply with all provisions of Executive Order 11246 of September 24, 1965, and of the rules, regulations and relevant orders of the Secretary of Labor.

E. The Contractor will furnish all information and reports required by Executive Order 11246 of September 24, 1965, and by rules, regulations and orders of the Secretary of Labor or pursuant thereto, and will permit access to his or her books, records and accounts by DuPage County, HUD and the Secretary of Labor for purposes of investigation to ascertain compliance with such rules, regulations and orders.

F. In the event of the Contractor’s noncompliance with the nondiscrimination clauses of this contract or with any of the said rules, regulations or orders, this contract may be canceled, terminated or suspended in whole or in part, and the Contractor may be declared ineligible for further Government contracts in accordance with procedures authorized in Executive

Order 11246 of September 24, 1965, or by rule, regulation or order of the Secretary of Labor or as otherwise provided by law.

- G. The Contractor will include the provisions of the sentence immediately preceding paragraph (1) and the provisions of paragraphs (A) through (G) in every subcontract or purchase order unless exempted by rules, regulations or orders of the Secretary of Labor issued pursuant to Section 204 of Executive Order 11246 of September 24, 1965, so that such provisions will be binding upon each subcontractor or vendor. The Contractor will take such action with respect to any subcontractor or purchase order as DuPage County or HUD may direct as means of enforcing such provisions, including sanctions for noncompliance. Provided, however, that in the event the Contractor becomes involved in or threatened with litigation with a subcontractor or vendor as a result of such direction by DuPage County or HUD, the Contractor may request the United States to enter into such litigation to protect the interest of the United States.

IV. NOTICE OF REQUIREMENT FOR AFFIRMATIVE ACTION TO ENSURE EQUAL EMPLOYMENT OPPORTUNITY *(Executive Order 11246, applicable to contracts/subcontracts exceeding \$10,000)*

- A. The Offeror or Bidder's attention is called the "Equal Opportunity Clause" and the "Standard Equal Employment Opportunity Construction Contract Specifications" set Herein.
- B. The goals and timetables for minority and female participation, expressed in percentage terms for the Contractor's aggregate workforce in each trade on all construction work in the covered area, are as follows:
 - 1. Until further notice the goal for women participation is 6.9% (Nationwide).
 - 2. Until further notice the goal for minority participation is 19.6% (Chicago PMSA).
- C. These goals are applicable to all Contractor's construction work (whether or not it is Federal or Federally assisted) performed in the covered area.
- D. The Contractor's compliance with the Executive Order and the regulations in 41 CFR, Part 60.4 shall be based on its implementation of the Equal Opportunity Clause, specific affirmative action obligations required by the specifications set forth in 41 CFR, Part 60-4.3(a), and its efforts to meet the goals established for the geographical area where the contract resulting from this solicitation is to be performed. The hours of minority and female employment and training must be substantially uniform throughout the length of the contract, and in each trade, and the Contractor shall make a good faith effort to employ minorities and women evenly on each of its projects. The transfer of minority or female employees or trainees from contractor to contractor or from project to project for the sole purpose of meeting the contractor's goals shall be a violation of contract, the Executive Order and the regulations in 41 CFR, Part 60.4. Compliance with the goals will be measured against the total work hours performed.
- E. The Contractor shall provide written notification to the Director of the Office of Federal Contract Compliance Programs within ten (10) working days of award of any construction subcontract in excess of \$10,000 at any tier for construction work under the contract resulting from this solicitation. The notification shall list the name, address and telephone number of the Subcontractor; employer identification number, estimated dollar amount of the

subcontract, estimated starting and completion dates of the subcontract, and the geographical area in which the contract is to be performed.

- F. As used in this Notice, and in the contract resulting from this solicitation, the “covered area” is Chicago PMSA.

V. FEDERAL EQUAL EMPLOYMENT OPPORTUNITY CONSTRUCTION CONTRACT SPECIFICATIONS (*Executive Order 11246*)

A. As Used In These Specifications:

1. “Covered Area” means the geographical area described in the solicitation from which this contract is resulted.
2. “Director” means Director, Office of Federal Contract Compliance Programs, United States Department of Labor or any person to whom the Director delegates authority.
3. “Employer identification numbers” means the Federal Social Security number used on the Employer’s Quarterly Federal Tax Return, U. S. Treasury Department Form 941.

B. “Minority” Includes:

1. *Black* - All persons having origins in any of the Black African racial groups not of Hispanic origin.
2. *Hispanic* – All persons of Mexican, Puerto Rican, Cuban, Central and South American or other Spanish Culture or origin, regardless of race.
3. *Asian and Pacific Islander* – All persons having origins in any of the original peoples of the Far East, Southeast Asia, the Indian Subcontinent, or the Pacific Islands.
4. *American Indian or Alaskan Native* – All persons having origins in any of the original peoples of North America and maintaining identifiable tribal affiliations through membership and participation or community identification.

C. Subcontracts

1. Whenever the Contractor or any Subcontractor at any tier, subcontracts a portion of the work involving any construction trade, it shall physically include in each subcontract in excess of \$10,000 the provisions of these specifications and the Notice which contains the applicable goals for minority and female participation and which is set forth in the solicitations from which this contract resulted.
2. If the Contractor is participating (pursuant to the 41 CFR, Part 60 4.5) in a Hometown Plan approved by the U. S. Department of Labor in the covered area either individually or through an association, its affirmative action obligations on all work in the Plan area (including goals and timetables) shall be in accordance with the Plan for those trades which have unions participating in the Plan. Contractors must be able to demonstrate their participation in and compliance with the provisions of any such Hometown Plan. Each Contractor or Subcontractor participating in an approved Plan is individually required to comply with its obligations under the EEO clause, and to make a good faith effort to achieve each goal under the Plan in each trade in which it has employees. The overall good faith performance by other contractors or subcontractors toward a goal in an

approved Plan does not excuse any covered Contractor or Subcontractor's failure to take good faith efforts to achieve the Plan goals and timetables.

3. The Contractor shall implement the specific affirmative action standards provided in paragraphs 7 (I) through (XVI) of these specifications. The goals set forth in the solicitation from which this contract resulted are expressed as percentages of the total hours of employment and training of minority and female utilization the Contractor should reasonably be able to achieve in each construction trade in which it has employees in the covered area. The Contractor is expected to make substantially uniform progress toward its goals in each craft during the period specified.
4. Neither the provisions of any collective bargaining agreement, nor the failure by a union with whom the Contractor has a collective bargaining agreement, to refer either minorities or women shall excuse the Contractor's obligations under these specifications, Executive Order 11246 or the regulations promulgated pursuant thereto.
5. In order for the nonworking training hours of apprentices and trainees to be counted in meeting the goals, such apprentices and trainees must be employed by the Contractor during the training period, and the Contractor must have made a commitment to employ the apprentices and trainees at the completion of their training, subject to the availability of employment opportunities. Trainees must be trained pursuant to training programs approved by the U. S. Department of Labor.
6. The Contractor shall take specific affirmative actions to ensure equal employment opportunity. The evaluation of the Contractor's compliance with these specifications shall be based upon its effort to achieve maximum results from its actions. The Contractor shall document these efforts fully and shall implement affirmative action steps at least as extensive as the following.

D. Equal Employment Opportunity Documentation

1. Ensure and maintain a working environment free of harassment, intimidation and coercion at all sites, and in tall facilities at which the Contractor's employees are assigned to work. The Contractor, where possible, will assign two or more women to each construction project. The Contractor shall specifically ensure that all foremen, superintendents and other on-site supervisory personnel are aware of any carrying out of the Contractor's obligation to maintain such a working environment, with specific attention to minority or female individuals working at such sites or in such facilities.
2. Establish and maintain a current list of minority and female recruitment sources, provide written notification to minority and female recruitment sources and to community organizations when the Contractor or its unions have employment opportunities available, and maintain a record of organization's responses.
3. Maintain a current file of the names, addresses and telephone numbers of each minority and female off-the-street applicant and minority or female referral from a union, a recruitment source or community organization and of what action was taken with respect to each such individual. If such individuals were sent to the union hiring hall for referral and were not referred back to the Contractor by the union or, if referred, not employed by the Contractor, this shall be documented in the file with the reason, therefore along with whatever additional actions the Contractor may have taken.

4. Provide immediate written notification to the Director when the union or unions with which the Contractor has a collective bargaining agreement has not referred to the Contractor a minority person or woman sent by the Contractor or when the Contractor has other information that the union referral process has impeded the Contractor's efforts to meet its obligations.
5. Develop on-the-job training opportunities and/or participate in training programs for the area which expressly include minorities and women and apprenticeship and trainee programs relevant to the Contractor's employment needs, especially those programs funded or approved by the Department of Labor. The Contractor shall provide notice of these programs to the sources compiled under D (2) above.
6. Disseminate the Contractor's EEO policy by providing notice of the policy to unions and training programs and requesting their cooperation in assisting the Contractor in meeting its EEO obligations; by including it in any policy manual and collective bargaining agreement by publicizing it in the company newspaper, annual report, etc; by specific review of the policy with all management personnel and with all minority and female employees at least once a year; and by posting the company EEO policy on bulletin boards accessible to all employees at each location where construction work is performed.
7. Review, at least annually, the company's EEO policy and affirmative action obligations under these specifications with all employees having any responsibility for hiring, assignment, layoff, termination or other employment decisions including specific review of these items with onsite supervisory personnel such as superintendents, general foremen, etc., prior to the initiation of construction work at any job site. A written record shall be made and maintained identifying the time and place of these meetings, persons attending, subject matter discussed, and the disposition of the subject matter.
8. Disseminate the Contractor's EEO policy externally by including it in any advertising in the news media, specifically including minority and female news media, and providing written notification to and discussing the Contractor's EEO policy with other contractors and subcontractors with whom the Contractor does or anticipates doing business.
9. Direct its recruitment efforts, both oral and written, to minority, female and community organizations, to schools with minority and female students, and to minority and female recruitment and training organizations serving the Contractor's recruitment area and employment needs. Not later than one month prior to the date for the acceptance of applications for apprenticeship or other training by any recruitment source, the Contractor shall send written notification to organizations, such as the above, describing the openings, screening procedures and tests to be used in the selection process.
10. Encourage present minority and female employees to recruit other minority persons and women, and where reasonable, provide after school, summer and vacation employment to minority and female youth, both on the site and in other areas of Contractor's work force.
11. Validate all tests and other selection requirements where there is an obligation to do so under 41 CFR, Part 60, 3.
12. Conduct, at least annually, an inventory and evaluation of at least of all minority and female personnel for promotional opportunities and encourage these employees to seek or to prepare for (through appropriate training, etc.) such opportunities.

13. Ensure that seniority practices, job classifications, work assignments and other personnel practices, do not have a discriminatory effect by continually monitoring all personnel and employment related activities to ensure that the EEO policy and the Contractor's obligations under these specifications are being carried out.
14. Ensure that all facilities and company activities are non-segregated except that separate or single user toilet and necessary changing facilities shall be provided to ensure privacy between the sexes.
15. Document and maintain a record of all solicitations of offers for subcontracts from minority and female construction contractors and suppliers, including circulation of solicitations to minority and female contractor associations and other business associations.
16. Conduct a review, at least annually, of all supervisors' adherence to and performance under the Contractor's EEO policies and affirmative action obligations.
17. Covered construction contractors performing contracts in geographical areas where they do not have a Federal or federally assisted construction contract shall apply the minority and female goals established for the geographical area where the contract is being performed. Goals are published periodically in the Federal Register in notice form and such notices may be obtained from any Office of Federal Contract Compliance Programs office from Federal Procurement contracting officers.

E. Voluntary Associations

1. Contractors are encouraged to participate in voluntary associations, which assist in fulfilling one or more of their affirmative action obligations, D-1 through D-17. The efforts of a contractor association, joint contractor-union, contractor-community or other similar group of which the Contractor is a member and participant, may be asserted as fulfilling any one or more of its obligations under D-1 through D17 of these specifications provided that the Contractor actively participates in the group, makes every effort to assure that the group has a positive impact on employment of minorities and women in the industry, ensures that the concrete benefits of the program are reflected in the Contractor's minority and female workforce participation, makes a good faith effort to meet individual goals and timetables, and can provide access to documentation which demonstrates the effectiveness of actions taken on behalf of the Contractor. The obligation shall not be a defense for the Contractor's non-compliance.
2. A single goal for minorities and a separate single goal for women have been established. The Contractor, however, is required to provide equal employment opportunity and to take affirmative action for all minority groups, both male and female, and all women, both minority and non-minority. Consequently, the Contractor may be in violation of the Executive Order if a particular group is employed in a substantially disparate manner (for example, even though the Contractor has achieved its goals for women generally, the Contractor may be in violation of the Executive order if a specific minority group of women is under utilized).
3. The Contractor shall not use the goals and timetables or affirmative action standards to discriminate against any person because of race, color, religion, sex or national origin.

4. The Contractor shall not enter into any subcontract with any person or firm debarred from Government contracts pursuant to Executive Order 11246, as amended.
5. The Contractor shall carry out such sanctions and penalties for violation of these specifications and of the Equal Opportunity Clause, including suspension, termination and cancellation of existing subcontracts as may be imposed or ordered pursuant to the Executive Order 11246, as amended, and its implementing regulations, by the Office of Federal Contract Compliance Programs. Any contractor who fails to carry out such sanctions and penalties shall be in violation of these specifications and Executive Order 11246, as amended.
6. The Contractor, in fulfilling its obligations under these specifications, shall implement specific affirmative action steps, at least as extensive as those standards prescribed in paragraph 7 of these specifications, so as to achieve maximum results from its efforts to ensure equal employment opportunity. If the Contractor fails to comply with the requirements of the Executive Order, the implementing regulations or these specifications, the Director shall proceed in accordance with 41 CFR, Part 60,4.8.
7. The Contractor shall designate a responsible official to monitor all employment related activity to ensure that the company EEO policy is being carried out, to submit reports relating to the provisions hereof as may be required by the Government and to keep records. Records shall at least include for each employee the name, address, telephone numbers, construction trade, union affiliation (if any), employee identification number when assigned, social security number, race, sex, status (e.g. mechanic, apprentice trainee, helper or laborer), dates of changes in status, hours worked per week in the indicated rate of pay and locations at which the work was performed. Records shall be maintained in an easily understandable and retrievable form; however, to the degree that existing records satisfy this requirement, contractors shall not be required to maintain separate records.
8. Nothing herein provided shall be construed as a limitation upon the application of other laws, which establish different standards of compliance or upon the application of requirements for the hiring of local or other area residents (e.g. those under the Public Works Employment Act of 1977 and the Community Development Block Grant Program).

F. *Civil Rights Act of 1964*

Under the Title VI of the Civil Rights Act of 1964, no person shall, on the grounds of race, color or national origin, be excluded from participation in, be denied the benefits of or be subjected to discrimination under any program or activity receiving Federal financial assistance.

G. *Section 109 Of The Housing And Community Development Act Of 1974*

No person in the United States shall on the ground of race, color, national origin or sex be excluded from participation in, be denied the benefits of or be subjected to discrimination under any program or activity funded in whole or in part with funds made available under this title.

H. *“Section 3” Compliance In The Provisions Of Training, Employment And Business Opportunities*

1. The work to be performed under this contract is subject to the requirements of Section 3 of the Housing and Urban Development Act of 1968, as amended, 12 USC 1701u (Section 3).

2. The purpose of Section 3 is to ensure that employment and other economic opportunities generated by HUD assistance or HUD-assisted projects covered by Section 3, shall, to be the greatest extent feasible, be directed to low and very low-income persons, particularly persons who are recipients of HUD assistance for housing.
3. The parties to this contract agree to comply with HUD's regulations in 24 CFR, Part 135, which implement Section 3. As evidenced by their execution of this contract, the parties to this contract certify that they are under no contractual or other impediment that would prevent them from complying with Part 135 requirements.
4. The Contractor agrees to send to each labor organization or representative of workers with which the Contractor has a collective bargaining agreement or other understanding, if any, a notice advising the labor organization or workers' representative of the Contractor's commitments under this Section 3 clause, and will post copies of the notice in conspicuous places at the work site where both employees and applicants for training and employment positions can see the notice. The notice shall describe the Section 3 preference, shall set forth minimum number and job titles subject to hire, availability of apprenticeship and training positions and the qualifications for each, and the name and location of the person(s) taking applications for each of the positions, and the anticipated date the work shall begin.
5. The Contractor agrees to include this Section 3 clause in every subcontract subject to compliance with regulations in 24 CFR, Part 135, and agrees to take appropriate action as provided in the applicable provision of the subcontract in this Section 3 clause, upon a finding that the Subcontractor is in violation of the regulations in 24 CFR, Part 135. The Contractor will not subcontract with any Subcontractor where the Contractor has notice or knowledge that the Subcontractor has been found in violation of regulations under 24 CFR, Part 135.
6. The Contractor will certify that any vacant employment positions, including training positions, that are filled (1) after the contractor is selected but before the contract is executed, and (2) with persons other than those to whom the regulations of 24 CFR, Part 135 require employment opportunities to be directed, were not filled to circumvent the Contractor's obligations under 24 CFR, Part 135.
7. Noncompliance with HUD's regulations in 24 CFR, Part 135 may result in sanctions, termination of this contract for default and debarment or suspension from future HUD-assisted contracts.

VI. CONTRACT WORK HOURS AND SAFETY STANDARDS

As a condition of any grant, contract, loan, insurance or guarantee involving federally assisted construction, DuPage County requires the following language to be included in full in any contract subject to the Contract Work Hours and Safety Standards ACT. As used in the section, the terms "laborers" and "mechanics" include watchmen and guards.

"The subgrantee, in accordance with Title 29, CFR, Part 5, hereby agrees that it will ensure the inclusion in all construction contract documents and bid specifications".

A. Overtime Requirements

No Contractor or Subcontractor contracting for any part of the contract work which may require or involve the employment of laborers or mechanics shall require or permit any laborer or mechanic in any workweek in which he is employed on such work to work in excess of forty hours in such workweek unless such laborer or mechanic receives compensation at a rate not less than one and one-half times his basic rate of pay for all hours worked in excess of forty hours in such workweek.

B. Violation and Liability for Unpaid Wages and Liquidated Damages

In the event of any violation of the clause set forth in Subsection A, the Contractor and any Subcontractor responsible therefore shall be liable to any affected employee for his unpaid wages. In addition, such Contractor and Subcontractor shall be to the United States for liquidated damages. Such liquidated damages shall be computed with respect to each individual laborer or mechanic employed in violation of the clause set forth in Subsection A, in the sum of \$10 for each calendar day on which such employee was required or permitted to work in excess of the standard workweek of forty hours without payment of the overtime wages required by the clause set forth in Subsection A.

C. Withholding for Unpaid Wages and Liquidated Damages

The DuPage County Community Development Specialist may withhold or cause to be withheld from any monies payable on account of work performed by the Contractor or Subcontractor such sums as may administratively be determined to be necessary to satisfy an liabilities of such Contractor or Subcontractor for unpaid wages and liquidated damages as provided in the clause set forth in Subsection B.

D. Subcontract

The Contractor shall insert in any subcontracts the clauses set for in subsections A, B and C of this section and also a clause requiring the subcontractors to include these clauses in any lower tier subcontracts which they may enter into, together with a clause requiring this insertion in any further subcontracts they may in turn be made.

E. Contractor's Responsibility

The Contractor shall be responsible for compliance by any Subcontractor or lower tier subcontractor with the clauses set forth in Subparagraph A through D.

VII. SAFETY

In the performance of this contract, the Contractor shall comply with all applicable Federal, State and local laws governing safety, health and sanitation. The Contractor shall provide all safeguards, safety devices and protective equipment, and take any other needed actions, on his own responsibility or the DuPage County Community Development Specialist may determine reasonably necessary to protect the life and health of employees on the job and the safety of the public and to protect property in connection with the performance of the work covered by the contract.

VIII. FALSE STATEMENTS CONCERNING PROJECTS

In order to assure high quality and durable construction in conformity with approved plans and specifications and a high degree of reliability on statements and representations made by engineers, contractors, suppliers and workers on projects utilizing Federal funds, it is essential

that all persons concerned with the project perform their functions as carefully, thoroughly and honestly as possible. Willful falsification, distortion or misrepresentation with respect to any facts related to the project is a violation of Federal law.

IX. IMPLEMENTATION OF CLEAN AIR ACT

Contract requirements

- A. The Contractor stipulates that any facility to be utilized in the performance of this contract, unless such contract is exempt under the Clean Air Act, as amended (PL 91-604, 42 U.S.C 1857, as amended by PL 95-95 and PL 95-960, 42 USC 4362, 7401 et Seq.), Executive Order 11738, and regulations in implementation thereof (40 CFR, Part 15) is not listed, on the date of contract award, on the U.S. Environmental Protection Agency (EPA) List of Violating Facilities Pursuant to Title 40 CFR, Part 15.
- B. The Contractor agrees to comply with all the requirements of Section 114 of the Clean Air Act, as amended, relating to inspection, monitoring, entry reports and information, as well as, all other requirements specified in Section 114 and all regulations and guidelines listed there under.
- C. The Contractor shall promptly notify the Community Development Specialist of the receipt of any communication from the Director, Office of Federal Activities, or the EPA, indicating that a facility to be utilized for the contract is under consideration to be listed on the EPA Listing of Violating Facilities.
- D. The Contractor agrees to include or cause to be included the requirements of subparagraphs A through D of this section in every nonexempt subcontract and further agrees to take such action as the Government may direct as a means of enforcing such requirements.

X. LABOR STANDARDS

Except as otherwise provided, DuPage County requires the inclusion of the HUD Federal Labor Standards Provisions Form 4010 as a condition of any grant, contract, loan, insurance or guarantee involving federally assisted construction.

EXECUTIVE ORDER 11246 EQUAL EMPLOYMENT OPPORTUNITY

SOURCE: The provisions of Executive Order 11246 of Sept. 24, 1965, appear at 30 FR 12319, 12935, 3 CFR, 1964-1965 Comp., p.339, unless otherwise noted.

Under and by virtue of the authority vested in me as President of the United States by the Constitution and statutes of the United States, it is ordered as follows:

Part I - Nondiscrimination in Government Employment

[Part I superseded by EO 11478 of Aug. 8, 1969, 34 FR 12985, 3 CFR, 1966-1970 Comp., p. 803]

Part II - Nondiscrimination in Employment by Government Contractors and Subcontractors

Subpart A - Duties of the Secretary of Labor

SEC. 201. The Secretary of Labor shall be responsible for the administration and enforcement of Parts II and III of this Order. The Secretary shall adopt such rules and regulations and issue such orders as are deemed necessary and appropriate to achieve the purposes of Parts II and III of this Order.

[Sec. 201 amended by EO 12086 of Oct. 5, 1978, 43 FR 46501, 3 CFR, 1978 Comp., p. 230]

Subpart B - Contractors' Agreements

SEC. 202. Except in contracts exempted in accordance with Section 204 of this Order, all Government contracting agencies shall include in every Government contract hereafter entered into the following provisions:

During the performance of this contract, the contractor agrees as follows:

(1) The contractor will not discriminate against any employee or applicant for employment because of race, color, religion, sex, or national origin. The contractor will take affirmative action to ensure that applicants are employed, and that employees are treated during employment, without regard to their race, color, religion, sex or national origin. Such action shall include, but not be limited to the following: employment, upgrading, demotion, or transfer; recruitment or recruitment advertising; layoff or termination; rates of pay or other forms of compensation; and selection for training, including apprenticeship. The contractor agrees to post in conspicuous places, available to employees and applicants for employment, notices to be provided by the contracting officer setting forth the provisions of this nondiscrimination clause.

(2) The contractor will, in all solicitations or advancements for employees placed by or on behalf of the contractor, state that all qualified applicants will receive consideration for employment without regard to race, color, religion, sex or national origin.

(3) The contractor will send to each labor union or representative of workers with which he has a collective bargaining agreement or other contract or understanding, a notice, to be provided by the agency contracting officer, advising the labor union or workers' representative of the contractor's commitments under Section 202 of Executive Order No. 11246 of September 24,

1965, and shall post copies of the notice in conspicuous places available to employees and applicants for employment.

(4) The contractor will comply with all provisions of Executive Order No. 11246 of Sept. 24, 1965, and of the rules, regulations, and relevant orders of the Secretary of Labor.

(5) The contractor will furnish all information and reports required by Executive Order No. 11246 of September 24, 1965, and by the rules, regulations, and orders of the Secretary of Labor, or pursuant thereto, and will permit access to his books, records, and accounts by the contracting agency and the Secretary of Labor for purposes of investigation to ascertain compliance with such rules, regulations, and orders.

(6) In the event of the contractor's noncompliance with the nondiscrimination clauses of this contract or with any of such rules, regulations, or orders, this contract may be cancelled, terminated, or suspended in whole or in part and the contractor may be declared ineligible for further Government contracts in accordance with procedures authorized in Executive Order No. 11246 of Sept. 24, 1965, and such other sanctions may be imposed and remedies invoked as provided in Executive Order No. 11246 of September 24, 1965, or by rule, regulation, or order of the Secretary of Labor, or as otherwise provided by law.

(7) The contractor will include the provisions of paragraphs (1) through (7) in every subcontract or purchase order unless exempted by rules, regulations, or orders of the Secretary of Labor issued pursuant to Section 204 of Executive Order No. 11246 of September 24, 1965, so that such provisions will be binding upon each subcontractor or vendor. The contractor will take such action with respect to any subcontract or purchase order as may be directed by the Secretary of Labor as a means of enforcing such provisions including sanctions for noncompliance: Provided, however, that in the event the contractor becomes involved in, or is threatened with, litigation with a subcontractor or vendor as a result of such direction, the contractor may request the United States to enter into such litigation to protect the interests of the United States." [Sec. 202 amended by EO 11375 of Oct. 13, 1967, 32 FR 14303, 3 CFR, 1966-1970 Comp., p. 684, EO 12086 of Oct. 5, 1978, 43 FR 46501, 3 CFR, 1978 Comp., p. 230]

SEC. 203. Each contractor having a contract containing the provisions prescribed in Section 202 shall file, and shall cause each of his subcontractors to file, Compliance Reports with the contracting agency or the Secretary of Labor as may be directed. Compliance Reports shall be filed within such times and shall contain such information as to the practices, policies, programs, and employment policies, programs, and employment statistics of the contractor and each subcontractor, and shall be in such form, as the Secretary of Labor may prescribe.

(b) Bidders or prospective contractors or subcontractors may be required to state whether they have participated in any previous contract subject to the provisions of this Order, or any preceding similar Executive order, and in that event to submit, on behalf of themselves and their proposed subcontractors, Compliance Reports prior to or as an initial part of their bid or negotiation of a contract.

(c) Whenever the contractor or subcontractor has a collective bargaining agreement or other contract or understanding with a labor union or an agency referring workers or providing or supervising apprenticeship or training for such workers, the Compliance Report shall include such information as to such labor union's or agency's practices and policies affecting compliance as the Secretary of Labor may prescribe: Provided, That to the extent such information is within the exclusive possession of a labor union or an agency referring workers or providing or supervising apprenticeship or training and such labor union or agency shall refuse to furnish such information to the contractor, the contractor shall so certify to the Secretary of Labor as part of its Compliance Report and shall set forth what efforts he has made to obtain such information.

(d) The Secretary of Labor may direct that any bidder or prospective contractor or subcontractor shall submit, as part of his Compliance Report, a statement in writing, signed by an authorized officer or agent on behalf of any labor union or any agency referring workers or providing or

supervising apprenticeship or other training, with which the bidder or prospective contractor deals, with supporting information, to the effect that the signer's practices and policies do not discriminate on the grounds of race, color, religion, sex or national origin, and that the signer either will affirmatively cooperate in the implementation of the policy and provisions of this Order or that it consents and agrees that recruitment, employment, and the terms and conditions of employment under the proposed contract shall be in accordance with the purposes and provisions of the order. In the event that the union, or the agency shall refuse to execute such a statement, the Compliance Report shall so certify and set forth what efforts have been made to secure such a statement and such additional factual material as the Secretary of Labor may require.

[Sec. 203 amended by EO 11375 of Oct. 13, 1967, 32 FR 14303, 3 CFR, 1966-1970 Comp., p. 684; EO 12086 of Oct. 5, 1978, 43 FR 46501, 3 CFR, 1978 Comp., p. 230]

SEC. 204 (a) The Secretary of Labor may, when the Secretary deems that special circumstances in the national interest so require, exempt a contracting agency from the requirement of including any or all of the provisions of Section 202 of this **Order** in any specific contract, subcontract, or purchase **order**.

(b) The Secretary of Labor may, by rule or regulation, exempt certain classes of contracts, subcontracts, or purchase orders (1) whenever work is to be or has been performed outside the United States and no recruitment of workers within the limits of the United States is involved; (2) for standard commercial supplies or raw materials; (3) involving less than specified amounts of money or specified numbers of workers; or (4) to the extent that they involve subcontracts below a specified tier.

(c) Section 202 of this **Order** shall not apply to a Government contractor or subcontractor that is a religious corporation, association, educational institution, or society, with respect to the employment of individuals of a particular religion to perform work connected with the carrying on by such corporation, association, educational institution, or society of its activities. Such contractors and subcontractors are not exempted or excused from complying with the other requirements contained in this **Order**.

(d) The Secretary of Labor may also provide, by rule, regulation, or order, for the exemption of facilities of a contractor that are in all respects separate and distinct from activities of the contractor related to the performance of the contract: provided, that such an exemption will not interfere with or impede the effectuation of the purposes of this **Order**: and provided further, that in the absence of such an exemption all facilities shall be covered by the provisions of this **Order**."

[Sec. 204 amended by EO 13279 of Dec. 16, 2002, 67 FR 77141, 3 CFR, 2002 Comp., p. 77141 - 77144]

Subpart C - Powers and Duties of the Secretary of Labor and the Contracting Agencies

SEC. 205. The Secretary of Labor shall be responsible for securing compliance by all Government contractors and subcontractors with this Order and any implementing rules or regulations. All contracting agencies shall comply with the terms of this Order and any implementing rules, regulations, or orders of the Secretary of Labor. Contracting agencies shall cooperate with the Secretary of Labor and shall furnish such information and assistance as the Secretary may require.

[Sec. 205 amended by EO 12086 of Oct. 5, 1978, 43 FR 46501, 3 CFR, 1978 Comp., p. 230]

SEC. 206. The Secretary of Labor may investigate the employment practices of any Government contractor or subcontractor to determine whether or not the contractual provisions specified in Section 202 of this Order have been violated. Such investigation shall be conducted in accordance with the procedures established by the Secretary of Labor.

(b) The Secretary of Labor may receive and investigate complaints by employees or prospective employees of a Government contractor or subcontractor which allege discrimination contrary to the contractual provisions specified in Section 202 of this Order.

[Sec. 206 amended by EO 12086 of Oct. 5, 1978, 43 FR 46501, 3 CFR, 1978 Comp., p. 230]

SEC. 207. The Secretary of Labor shall use his/her best efforts, directly and through interested Federal, State, and local agencies, contractors, and all other available instrumentalities to cause any labor union engaged in work under Government contracts or any agency referring workers or providing or supervising apprenticeship or training for or in the course of such work to cooperate in the implementation of the purposes of this Order. The Secretary of Labor shall, in appropriate cases, notify the Equal Employment Opportunity Commission, the Department of Justice, or other appropriate Federal agencies whenever it has reason to believe that the practices of any such labor organization or agency violate Title VI or Title VII of the Civil Rights Act of 1964 or other provision of Federal law.

[Sec. 207 amended by EO 12086 of Oct. 5, 1978, 43 FR 46501, 3 CFR, 1978 Comp., p. 230]

SEC. 208. The Secretary of Labor, or any agency, officer, or employee in the executive branch of the Government designated by rule, regulation, or order of the Secretary, may hold such hearings, public or private, as the Secretary may deem advisable for compliance, enforcement, or educational purposes.

(b) The Secretary of Labor may hold, or cause to be held, hearings in accordance with Subsection of this Section prior to imposing, ordering, or recommending the imposition of penalties and sanctions under this Order. No order for debarment of any contractor from further Government contracts under Section 209(6) shall be made without affording the contractor an opportunity for a hearing.

Subpart D - Sanctions and Penalties

SEC. 209. In accordance with such rules, regulations, or orders as the Secretary of Labor may issue or adopt, the Secretary may:

(1) Publish, or cause to be published, the names of contractors or unions which it has concluded have complied or have failed to comply with the provisions of this Order or of the rules, regulations, and orders of the Secretary of Labor.

(2) Recommend to the Department of Justice that, in cases in which there is substantial or material violation or the threat of substantial or material violation of the contractual provisions

set forth in Section 202 of this Order, appropriate proceedings be brought to enforce those provisions, including the enjoining, within the limitations of applicable law, of organizations, individuals, or groups who prevent directly or indirectly, or seek to prevent directly or indirectly, compliance with the provisions of this Order.

(3) Recommend to the Equal Employment Opportunity Commission or the Department of Justice that appropriate proceedings be instituted under Title VII of the Civil Rights Act of 1964.

(4) Recommend to the Department of Justice that criminal proceedings be brought for the furnishing of false information to any contracting agency or to the Secretary of Labor as the case may be.

(5) After consulting with the contracting agency, direct the contracting agency to cancel, terminate, suspend, or cause to be cancelled, terminated, or suspended, any contract, or any portion or portions thereof, for failure of the contractor or subcontractor to comply with equal employment opportunity provisions of the contract. Contracts may be cancelled, terminated, or suspended absolutely or continuance of contracts may be conditioned upon a program for future compliance approved by the Secretary of Labor.

(6) Provide that any contracting agency shall refrain from entering into further contracts, or extensions or other modifications of existing contracts, with any noncomplying contractor, until such contractor has satisfied the Secretary of Labor that such contractor has established and will carry out personnel and employment policies in compliance with the provisions of this Order.

(b) Pursuant to rules and regulations prescribed by the Secretary of Labor, the Secretary shall make reasonable efforts, within a reasonable time limitation, to secure compliance with the contract provisions of this Order by methods of conference, conciliation, mediation, and persuasion before proceedings shall be instituted under subsection (a)(2) of this Section, or before a contract shall be cancelled or terminated in whole or in part under subsection (a)(5) of this Section.

[Sec. 209 amended by EO 12086 of Oct. 5, 1978, 43 FR 46501, 3 CFR, 1978 Comp., p. 230]

SEC. 210. Whenever the Secretary of Labor makes a determination under Section 209, the Secretary shall promptly notify the appropriate agency. The agency shall take the action directed by the Secretary and shall report the results of the action it has taken to the Secretary of Labor within such time as the Secretary shall specify. If the contracting agency fails to take the action directed within thirty days, the Secretary may take the action directly.

[Sec. 210 amended by EO 12086 of Oct. 5, 1978, 43 FR 46501, 3 CFR, 1978 Comp., p. 230]

SEC. 211. If the Secretary shall so direct, contracting agencies shall not enter into contracts with any bidder or prospective contractor unless the bidder or prospective contractor has satisfactorily complied with the provisions of this Order or submits a program for compliance acceptable to the Secretary of Labor.

[Sec. 211 amended by EO 12086 of Oct. 5, 1978, 43 FR 46501, 3 CFR, 1978 Comp., p. 230]

SEC. 212. When a contract has been cancelled or terminated under Section 209(a)(5) or a contractor has been debarred from further Government contracts under Section 209(a)(6) of this Order, because of noncompliance with the contract provisions specified in Section 202 of this Order, the Secretary of Labor shall promptly notify the Comptroller General of the United States.

[Sec. 212 amended by EO 12086 of Oct. 5, 1978, 43 FR 46501, 3 CFR, 1978 Comp., p. 230]

Subpart E - Certificates of Merit

SEC. 213. The Secretary of Labor may provide for issuance of a United States Government Certificate of Merit to employers or labor unions, or other agencies which are or may hereafter be engaged in work under Government contracts, if the Secretary is satisfied that the personnel and employment practices of the employer, or that the personnel, training, apprenticeship,

membership, grievance and representation, upgrading, and other practices and policies of the labor union or other agency conform to the purposes and provisions of this Order.

SEC. 214. Any Certificate of Merit may at any time be suspended or revoked by the Secretary of Labor if the holder thereof, in the judgment of the Secretary, has failed to comply with the provisions of this Order.

SEC. 215. The Secretary of Labor may provide for the exemption of any employer, labor union, or other agency from any reporting requirements imposed under or pursuant to this Order if such employer, labor union, or other agency has been awarded a Certificate of Merit which has not been suspended or revoked.

Part III - Nondiscrimination Provisions in Federally Assisted Construction Contracts

SEC. 301. Each executive department and agency, which administers a program involving Federal financial assistance shall require as a condition for the approval of any grant, contract, loan, insurance, or guarantee thereunder, which may involve a construction contract, that the applicant for Federal assistance undertake and agree to incorporate, or cause to be incorporated, into all construction contracts paid for in whole or in part with funds obtained from the Federal Government or borrowed on the credit of the Federal Government pursuant to such grant, contract, loan, insurance, or guarantee, or undertaken pursuant to any Federal program involving such grant, contract, loan, insurance, or guarantee, the provisions prescribed for Government contracts by Section 202 of this Order or such modification thereof, preserving in substance the contractor's obligations thereunder, as may be approved by the Secretary of Labor, together with such additional provisions as the Secretary deems appropriate to establish and protect the interest of the United States in the enforcement of those obligations. Each such applicant shall also undertake and agree (1) to assist and cooperate actively with the Secretary of Labor in obtaining the compliance of contractors and subcontractors with those contract provisions and with the rules, regulations and relevant orders of the Secretary, (2) to obtain and to furnish to the Secretary of Labor such information as the Secretary may require for the supervision of such compliance, (3) to carry out sanctions and penalties for violation of such obligations imposed upon contractors and subcontractors by the Secretary of Labor pursuant to Part II, Subpart D, of this Order, and (4) to refrain from entering into any contract subject to this Order, or extension or other modification of such a contract with a contractor debarred from Government contracts under Part II, Subpart D, of this Order.

[Sec. 301 amended by EO 12086 of Oct. 5, 1978, 43 FR 46501, 3 CFR, 1978 Comp., p. 230]

SEC. 302. "Construction contract" as used in this Order means any contract for the construction, rehabilitation, alteration, conversion, extension, or repair of buildings, highways, or other improvements to real property.

(b) The provisions of Part II of this Order shall apply to such construction contracts, and for purposes of such application the administering department or agency shall be considered the contracting agency referred to therein.

(c) The term "applicant" as used in this Order means an applicant for Federal assistance or, as determined by agency regulation, other program participant, with respect to whom an application for any grant, contract, loan, insurance, or guarantee is not finally acted upon prior to the effective date of this Part, and it includes such an applicant after he/she becomes a recipient of such Federal assistance.

SEC. 303. The Secretary of Labor shall be responsible for obtaining the compliance of such applicants with their undertakings under this Order. Each administering department and agency is directed to cooperate with the Secretary of Labor and to furnish the Secretary such

information and assistance as the Secretary may require in the performance of the Secretary's functions under this Order.

(b) In the event an applicant fails and refuses to comply with the applicant's undertakings pursuant to this Order, the Secretary of Labor may, after consulting with the administering department or agency, take any or all of the following actions: (1) direct any administering department or agency to cancel, terminate, or suspend in whole or in part the agreement, contract or other arrangement with such applicant with respect to which the failure or refusal occurred; (2) direct any administering department or agency to refrain from extending any further assistance to the applicant under the program with respect to which the failure or refusal occurred until satisfactory assurance of future compliance has been received by the Secretary of Labor from such applicant; and (3) refer the case to the Department of Justice or the Equal Employment Opportunity Commission for appropriate law enforcement or other proceedings.

(c) In no case shall action be taken with respect to an applicant pursuant to clause (1) or (2) of subsection (b) without notice and opportunity for hearing.

[Sec. 303 amended by EO 12086 of Oct. 5, 1978, 43 FR 46501, 3 CFR, 1978 Comp., p. 230]

SEC. 304. Any executive department or agency which imposes by rule, regulation, or order requirements of nondiscrimination in employment, other than requirements imposed pursuant to this Order, may delegate to the Secretary of Labor by agreement such responsibilities with respect to compliance standards, reports, and procedures as would tend to bring the administration of such requirements into conformity with the administration of requirements imposed under this Order: Provided, That actions to effect compliance by recipients of Federal financial assistance with requirements imposed pursuant to Title VI of the Civil Rights Act of 1964 shall be taken in conformity with the procedures and limitations prescribed in Section 602 thereof and the regulations of the administering department or agency issued thereunder.

Part IV - Miscellaneous

SEC. 401. The Secretary of Labor may delegate to any officer, agency, or employee in the Executive branch of the Government, any function or duty of the Secretary under Parts II and III of this Order.

[Sec. 401 amended by EO 12086 of Oct. 5, 1978, 43 FR 46501, 3 CFR, 1978 Comp., p. 230]

SEC. 402. The Secretary of Labor shall provide administrative support for the execution of the program known as the "Plans for Progress."

SEC. 403. Executive Orders Nos. 10590 (January 19, 1955), 10722 (August 5, 1957), 10925 (March 6, 1961), 11114 (June 22, 1963), and 11162 (July 28, 1964), are hereby superseded and the President's Committee on Equal Employment Opportunity established by Executive Order No.

10925 is hereby abolished. All records and property in the custody of the Committee shall be transferred to the Office of Personnel Management and the Secretary of Labor, as appropriate.

(b) Nothing in this Order shall be deemed to relieve any person of any obligation assumed or imposed under or pursuant to any Executive Order superseded by this Order. All rules, regulations, orders, instructions, designations, and other directives issued by the President's Committee on Equal Employment Opportunity and those issued by the heads of various departments or agencies under or pursuant to any of the Executive orders superseded by this Order, shall, to the extent that they are not inconsistent with this Order, remain in full force and effect unless and until revoked or superseded by appropriate authority. References in such

directives to provisions of the superseded orders shall be deemed to be references to the comparable provisions of this Order.

[Sec. 403 amended by EO 12107 of Dec. 28, 1978, 44 FR 1055, 3 CFR, 1978 Comp., p, 264]

SEC. 404. The General Services Administration shall take appropriate action to revise the standard Government contract forms to accord with the provisions of this Order and of the rules and regulations of the Secretary of Labor.

SEC. 405. This Order shall become effective thirty days after the date of this Order.

NOT FOR BIDD

Applicability

The Project or Program to which the construction work covered by this contract pertains is being assisted by the United States of America and the following Federal Labor Standards Provisions are included in this Contract pursuant to the provisions applicable to such Federal assistance.

A. 1. (i) Minimum Wages. All laborers and mechanics employed or working upon the site of the work, will be paid unconditionally and not less often than once a week, and without subsequent deduction or rebate on any account (except such payroll deductions as are permitted by regulations issued by the Secretary of Labor under the Copeland Act (29 CFR Part 3), the full amount of wages and bona fide fringe benefits (or cash equivalents thereof) due at time of payment computed at rates not less than those contained in the wage determination of the Secretary of Labor which is attached hereto and made a part hereof, regardless of any contractual relationship which may be alleged to exist between the contractor and such laborers and mechanics. Contributions made or costs reasonably anticipated for bona fide fringe benefits under Section I(b)(2) of the Davis-Bacon Act on behalf of laborers or mechanics are considered wages paid to such laborers or mechanics, subject to the provisions of 29 CFR 5.5(a)(1)(iv); also, regular contributions made or costs incurred for more than a weekly period (but not less often than quarterly) under plans, funds, or programs, which cover the particular weekly period, are deemed to be constructively made or incurred during such weekly period. Such laborers and mechanics shall be paid the appropriate wage rate and fringe benefits on the wage determination for the classification of work actually performed, without regard to skill, except as provided in 29 CFR 5.5(a)(4). Laborers or mechanics performing work in more than one classification may be compensated at the rate specified for each classification for the time actually worked therein: Provided, That the employer's payroll records accurately set forth the time spent in each classification in which work is performed. The wage determination (including any additional classification and wage rates conformed under 29 CFR 5.5(a)(1)(ii) and the Davis-Bacon poster (WH-1321) shall be posted at all times by the contractor and its subcontractors at the site of the work in a prominent and accessible, place where it can be easily seen by the workers.

(ii) (a) Any class of laborers or mechanics which is not listed in the wage determination and which is to be employed under the contract shall be classified in conformance with the wage determination. HUD shall approve an additional classification and wage rate and fringe benefits therefor only when the following criteria have been met:

(1) The work to be performed by the classification requested is not performed by a classification in the wage determination; and

(2) The classification is utilized in the area by the construction industry; and

(3) The proposed wage rate, including any bona fide fringe benefits, bears a reasonable relationship to the wage rates contained in the wage determination.

(b) If the contractor and the laborers and mechanics to be employed in the classification (if known), or their representatives, and HUD or its designee agree on the classification and wage rate (including the amount designated for fringe benefits where appropriate), a report of the action taken shall be sent by HUD or its designee to the Administrator of the Wage and Hour Division, Employment Standards Administration, U.S. Department of Labor, Washington, D.C. 20210. The Administrator, or an authorized representative, will approve, modify, or disapprove every additional classification action within 30 days of receipt and so advise HUD or its designee or will notify HUD or its designee within the 30-day period that additional time is necessary. (Approved by the Office of Management and Budget under OMB control number 1215-0140.)

(c) In the event the contractor, the laborers or mechanics to be employed in the classification or their representatives, and HUD or its designee do not agree on the proposed classification and wage rate (including the amount designated for fringe benefits, where appropriate), HUD or its designee shall refer the questions, including the views of all interested parties and the recommendation of HUD or its designee, to the Administrator for determination. The Administrator, or an authorized representative, will issue a determination within 30 days of receipt and so advise HUD or its designee or will notify HUD or its designee within the 30-day period that additional time is necessary. (Approved by the Office of Management and Budget under OMB Control Number 1215-0140.)

(d) The wage rate (including fringe benefits where appropriate) determined pursuant to subparagraphs (1)(ii)(b) or (c) of this paragraph, shall be paid to all workers performing work in the classification under this contract from the first day on which work is performed in the classification.

(iii) Whenever the minimum wage rate prescribed in the contract for a class of laborers or mechanics includes a fringe benefit which is not expressed as an hourly rate, the contractor shall either pay the benefit as stated in the wage determination or shall pay another bona fide fringe benefit or an hourly cash equivalent thereof.

(iv) If the contractor does not make payments to a trustee or other third person, the contractor may consider as part

of the wages of any laborer or mechanic the amount of any costs reasonably anticipated in providing bona fide fringe benefits under a plan or program, Provided, That the Secretary of Labor has found, upon the written request of the contractor, that the applicable standards of the Davis-Bacon Act have been met. The Secretary of Labor may require the contractor to set aside in a separate account assets for the meeting of obligations under the plan or program. (Approved by the Office of Management and Budget under OMB Control Number 1215-0140.)

2. Withholding. HUD or its designee shall upon its own action or upon written request of an authorized representative of the Department of Labor withhold or cause to be withheld from the contractor under this contract or any other Federal contract with the same prime contractor, or any other Federally-assisted contract subject to Davis-Bacon prevailing wage requirements, which is held by the same prime contractor so much of the accrued payments or advances as may be considered necessary to pay laborers and mechanics, including apprentices, trainees and helpers, employed by the contractor or any subcontractor the full amount of wages required by the contract. In the event of failure to pay any laborer or mechanic, including any apprentice, trainee or helper, employed or working on the site of the work, all or part of the wages required by the contract, HUD or its designee may, after written notice to the contractor, sponsor, applicant, or owner, take such action as may be necessary to cause the suspension of any further payment, advance, or guarantee of funds until such violations have ceased. HUD or its designee may, after written notice to the contractor, disburse such amounts withheld for and on account of the contractor or subcontractor to the respective employees to whom they are due. The Comptroller General shall make such disbursements in the case of direct Davis-Bacon Act contracts.

3. (i) Payrolls and basic records. Payrolls and basic records relating thereto shall be maintained by the contractor during the course of the work preserved for a period of three years thereafter for all laborers and mechanics working at the site of the work. Such records shall contain the name, address, and social security number of each such worker, his or her correct classification, hourly rates of wages paid (including rates of contributions or costs anticipated for bona fide fringe benefits or cash equivalents thereof of the types described in Section 1(b)(2)(B) of the Davis-bacon Act), daily and weekly number of hours worked, deductions made and actual wages paid. Whenever the Secretary of Labor has found under 29 CFR 5.5 (a)(1)(iv) that the wages of any laborer or mechanic include the amount of any costs reasonably anticipated in providing benefits under a plan or program described in Section 1(b)(2)(B) of the Davis-Bacon Act, the contractor shall maintain records which show that the commitment to provide such benefits is enforceable, that the plan or program is financially responsible, and that the plan or program has been

communicated in writing to the laborers or mechanics affected, and records which show the costs anticipated or the actual cost incurred in providing such benefits. Contractors employing apprentices or trainees under approved programs shall maintain written evidence of the registration of apprenticeship programs and certification of trainee programs, the registration of the apprentices and trainees, and the ratios and wage rates prescribed in the applicable programs. (Approved by the Office of Management and Budget under OMB Control Numbers 1215-0140 and 1215-0017.)

(ii) (a) The contractor shall submit weekly for each week in which any contract work is performed a copy of all payrolls to HUD or its designee if the agency is a party to the contract, but if the agency is not such a party, the contractor will submit the payrolls to the applicant sponsor, or owner, as the case may be, for transmission to HUD or its designee. The payrolls submitted shall set out accurately and completely all of the information required to be maintained under 29 CFR 5.5(a)(3)(i) except that full social security numbers and home addresses shall not be included on weekly transmittals. Instead the payrolls shall only need to include an individually identifying number for each employee (e.g., the last four digits of the employee's social security number). The required weekly payroll information may be submitted in any form desired. Optional Form WH-347 is available for this purpose from the Wage and Hour Division Web site at <http://www.dol.gov/esa/whd/forms/wh347instr.htm> or its successor site. The prime contractor is responsible for the submission of copies of payrolls by all subcontractors. Contractors and subcontractors shall maintain the full social security number and current address of each covered worker, and shall provide them upon request to HUD or its designee if the agency is a party to the contract, but if the agency is not such a party, the contractor will submit the payrolls to the applicant sponsor, or owner, as the case may be, for transmission to HUD or its designee, the contractor, or the Wage and Hour Division of the Department of Labor for purposes of an investigation or audit of compliance with prevailing wage requirements. It is not a violation of this subparagraph for a prime contractor to require a subcontractor to provide addresses and social security numbers to the prime contractor for its own records, without weekly submission to HUD or its designee. (Approved by the Office of Management and Budget under OMB Control Number 1215-0149.)

(b) Each payroll submitted shall be accompanied by a "Statement of Compliance," signed by the contractor or subcontractor or his or her agent who pays or supervises the payment of the persons employed under the contract and shall certify the following:

(1) That the payroll for the payroll period contains the information required to be provided under 29 CFR 5.5 (a)(3)(ii), the appropriate information is being maintained under 29 CFR 5.5(a)(3)(i), and that such information is correct and complete;

(2) That each laborer or mechanic (including each helper, apprentice, and trainee) employed on the contract during the payroll period has been paid the full weekly wages earned, without rebate, either directly or indirectly, and that no deductions have been made either directly or indirectly from the full wages earned, other than permissible deductions as set forth in 29 CFR Part 3;

(3) That each laborer or mechanic has been paid not less than the applicable wage rates and fringe benefits or cash equivalents for the classification of work performed, as specified in the applicable wage determination incorporated into the contract.

(c) The weekly submission of a properly executed certification set forth on the reverse side of Optional Form WH-347 shall satisfy the requirement for submission of the "Statement of Compliance" required by subparagraph A.3.(ii)(b).

(d) The falsification of any of the above certifications may subject the contractor or subcontractor to civil or criminal prosecution under Section 1001 of Title 18 and Section 231 of Title 31 of the United States Code.

(iii) The contractor or subcontractor shall make the records required under subparagraph A.3.(i) available for inspection, copying, or transcription by authorized representatives of HUD or its designee or the Department of Labor, and shall permit such representatives to interview employees during working hours on the job. If the contractor or subcontractor fails to submit the required records or to make them available, HUD or its designee may, after written notice to the contractor, sponsor, applicant or owner, take such action as may be necessary to cause the suspension of any further payment, advance, or guarantee of funds. Furthermore, failure to submit the required records upon request or to make such records available may be grounds for debarment action pursuant to 29 CFR 5.12.

4. Apprentices and Trainees.

(i) **Apprentices.** Apprentices will be permitted to work at less than the predetermined rate for the work they performed when they are employed pursuant to and individually registered in a bona fide apprenticeship program registered with the U.S. Department of Labor, Employment and Training Administration, Office of Apprenticeship Training, Employer and Labor Services, or with a State Apprenticeship Agency recognized by the Office, or if a person is employed in his or her first 90 days of probationary employment as an apprentice in such an apprenticeship program, who is not individually registered in the program, but who has been certified by the Office of Apprenticeship Training, Employer and Labor Services or a State Apprenticeship Agency (where appropriate) to be eligible for probationary employment as an apprentice. The allowable ratio of apprentices to journeymen on the job site in any craft classification shall not be greater than the ratio permitted to the contractor as to the entire work force under the registered program. Any worker listed on a payroll at an apprentice wage rate, who

is not registered or otherwise employed as stated above, shall be paid not less than the applicable wage rate on the wage determination for the classification of work actually performed. In addition, any apprentice performing work on the job site in excess of the ratio permitted under the registered program shall be paid not less than the applicable wage rate on the wage determination for the work actually performed. Where a contractor is performing construction on a project in a locality other than that in which its program is registered, the ratios and wage rates (expressed in percentages of the journeyman's hourly rate) specified in the contractor's or subcontractor's registered program shall be observed. Every apprentice must be paid at not less than the rate specified in the registered program for the apprentice's level of progress, expressed as a percentage of the journeymen hourly rate specified in the applicable wage determination. Apprentices shall be paid fringe benefits in accordance with the provisions of the apprenticeship program. If the apprenticeship program does not specify fringe benefits, apprentices must be paid the full amount of fringe benefits listed on the wage determination for the applicable classification. If the Administrator determines that a different practice prevails for the applicable apprentice classification, fringes shall be paid in accordance with that determination. In the event the Office of Apprenticeship Training, Employer and Labor Services, or a State Apprenticeship Agency recognized by the Office, withdraws approval of an apprenticeship program, the contractor will no longer be permitted to utilize apprentices at less than the applicable predetermined rate for the work performed until an acceptable program is approved.

(ii) **Trainees.** Except as provided in 29 CFR 5.16, trainees will not be permitted to work at less than the predetermined rate for the work performed unless they are employed pursuant to and individually registered in a program which has received prior approval, evidenced by formal certification by the U.S. Department of Labor, Employment and Training Administration. The ratio of trainees to journeymen on the job site shall not be greater than permitted under the plan approved by the Employment and Training Administration. Every trainee must be paid at not less than the rate specified in the approved program for the trainee's level of progress, expressed as a percentage of the journeyman hourly rate specified in the applicable wage determination. Trainees shall be paid fringe benefits in accordance with the provisions of the trainee program. If the trainee program does not mention fringe benefits, trainees shall be paid the full amount of fringe benefits listed on the wage determination unless the Administrator of the Wage and Hour Division determines that there is an apprenticeship program associated with the corresponding journeyman wage rate on the wage determination which provides for less than full fringe benefits for apprentices. Any employee listed on the payroll at a trainee rate who is not registered and participating in a training plan approved by

the Employment and Training Administration shall be paid not less than the applicable wage rate on the wage determination for the work actually performed. In addition, any trainee performing work on the job site in excess of the ratio permitted under the registered program shall be paid not less than the applicable wage rate on the wage determination for the work actually performed. In the event the Employment and Training Administration withdraws approval of a training program, the contractor will no longer be permitted to utilize trainees at less than the applicable predetermined rate for the work performed until an acceptable program is approved.

(iii) Equal employment opportunity. The utilization of apprentices, trainees and journeymen under 29 CFR Part 5 shall be in conformity with the equal employment opportunity requirements of Executive Order 11246, as amended, and 29 CFR Part 30.

5. Compliance with Copeland Act requirements. The contractor shall comply with the requirements of 29 CFR Part 3 which are incorporated by reference in this contract

6. Subcontracts. The contractor or subcontractor will insert in any subcontracts the clauses contained in subparagraphs 1 through 11 in this paragraph A and such other clauses as HUD or its designee may by appropriate instructions require, and a copy of the applicable prevailing wage decision, and also a clause requiring the subcontractors to include these clauses in any lower tier subcontracts. The prime contractor shall be responsible for the compliance by any subcontractor or lower tier subcontractor with all the contract clauses in this paragraph.

7. Contract termination; debarment. A breach of the contract clauses in 29 CFR 5.5 may be grounds for termination of the contract and for debarment as a contractor and a subcontractor as provided in 29 CFR 5.12.

8. Compliance with Davis-Bacon and Related Act Requirements. All rulings and interpretations of the Davis-Bacon and Related Acts contained in 29 CFR Parts 1, 3, and 5 are herein incorporated by reference in this contract

9. Disputes concerning labor standards. Disputes arising out of the labor standards provisions of this contract shall not be subject to the general disputes clause of this contract. Such disputes shall be resolved in accordance with the procedures of the Department of Labor set forth in 29 CFR Parts 5, 6, and 7. Disputes within the meaning of this clause include disputes between the contractor (or any of its subcontractors) and HUD or its designee, the U.S. Department of Labor, or the employees or their representatives.

10. (i) Certification of Eligibility. By entering into this contract the contractor certifies that neither it (nor he or she) nor any person or firm who has an interest in the contractor's firm is a person or firm ineligible to be awarded Government contracts by virtue of Section 3(a) of the Davis-Bacon Act or 29 CFR 5.12(a)(1) or to be

awarded HUD contracts or participate in HUD programs pursuant to 24 CFR Part 24.

(ii) No part of this contract shall be subcontracted to any person or firm ineligible for award of a Government contract by virtue of Section 3(a) of the Davis-Bacon Act or 29 CFR 5.12(a)(1) or to be awarded HUD contracts or participate in HUD programs pursuant to 24 CFR Part 24.

(iii) The penalty for making false statements is prescribed in the U.S. Criminal Code, 18 U.S.C. 1001. Additionally, U.S. Criminal Code, Section 1010, Title 18, U.S.C., "Federal Housing Administration transactions", provides in part: "Whoever, for the purpose of . . . influencing in any way the action of such Administration . . . makes, utters or publishes any statement knowing the same to be false . . . shall be fined not more than \$5,000 or imprisoned not more than two years, or both."

11. Complaints, Proceedings, or Testimony by Employees. No laborer or mechanic to whom the wage, salary, or other labor standards provisions of this Contract are applicable shall be discharged or in any other manner discriminated against by the Contractor or any subcontractor because such employee has filed any complaint or instituted or caused to be instituted any proceeding or has testified or is about to testify in any proceeding under or relating to the labor standards applicable under this Contract to his employer.

B. Contract Work Hours and Safety Standards Act. The provisions of this paragraph B are applicable where the amount of the prime contract exceeds \$100,000. As used in this paragraph, the terms "laborers" and "mechanics" include watchmen and guards.

(1) Overtime requirements. No contractor or subcontractor contracting for any part of the contract work which may require or involve the employment of laborers or mechanics shall require or permit any such laborer or mechanic in any workweek in which the individual is employed on such work to work in excess of 40 hours in such workweek unless such laborer or mechanic receives compensation at a rate not less than one and one-half times the basic rate of pay for all hours worked in excess of 40 hours in such workweek.

(2) Violation; liability for unpaid wages; liquidated damages. In the event of any violation of the clause set forth in subparagraph (1) of this paragraph, the contractor and any subcontractor responsible therefor shall be liable for the unpaid wages. In addition, such contractor and subcontractor shall be liable to the United States (in the case of work done under contract for the District of Columbia or a territory, to such District or to such territory), for liquidated damages. Such liquidated damages shall be computed with respect to each individual laborer or mechanic, including watchmen and guards, employed in violation of the clause set forth in subparagraph (1) of this paragraph, in the sum of \$10 for each calendar day on which such individual was required or permitted to work in excess of the standard workweek of 40 hours without payment of the overtime wages required by the clause set forth in subparagraph (1) of this paragraph.

(3) Withholding for unpaid wages and liquidated damages. HUD or its designee shall upon its own action or upon written request of an authorized representative of the Department of Labor withhold or cause to be withheld, from any moneys payable on account of work performed by the contractor or subcontractor under any such contract or any other Federal contract with the same prime contract, or any other Federally-assisted contract subject to the Contract Work Hours and Safety Standards Act which is held by the same prime contractor such sums as may be determined to be necessary to satisfy any liabilities of such contractor or subcontractor for unpaid wages and liquidated damages as provided in the clause set forth in subparagraph (2) of this paragraph.

(4) Subcontracts. The contractor or subcontractor shall insert in any subcontracts the clauses set forth in subparagraph (1) through (4) of this paragraph and also a clause requiring the subcontractors to include these clauses in any lower tier subcontracts. The prime contractor shall be responsible for compliance by any subcontractor or lower tier subcontractor with the clauses set forth in subparagraphs (1) through (4) of this paragraph.

C. Health and Safety. The provisions of this paragraph C are applicable where the amount of the prime contract exceeds \$100,000.

(1) No laborer or mechanic shall be required to work in surroundings or under working conditions which are unsanitary, hazardous, or dangerous to his health and safety as determined under construction safety and health standards promulgated by the Secretary of Labor by regulation.

(2) The Contractor shall comply with all regulations issued by the Secretary of Labor pursuant to Title 29 Part 1926 and failure to comply may result in imposition of sanctions pursuant to the Contract Work Hours and Safety Standards Act, (Public Law 91-54, 83 Stat 96). 40 USC 3701 et seq.

(3) The contractor shall include the provisions of this paragraph in every subcontract so that such provisions will be binding on each subcontractor. The contractor shall take such action with respect to any subcontractor as the Secretary of Housing and Urban Development or the Secretary of Labor shall direct as a means of enforcing such provisions.

HUD REQUIRED GENERAL CONTRACTOR AND SUB-CONTRACTOR FORMS

THESE FORMS WILL NEED TO BE COMPLETED BY THE SUCCESSFUL BIDDER(S)

- ❑ Notification to the Office of Federal Contract Compliance Programs: This form applies to the successful bidder(s) and all subcontractors with contracts of \$10,000 or greater. Mail this form to U.S. Department of Labor. Copies to Owner and DuPage County.

ORIGINALS OF ALL OF THE FOLLOWING FORMS MUST BE SENT TO OWNER

- ❑ Ownership Form
- ❑ Contractor / Subcontractor Labor Relations Agreement
- ❑ Apprenticeship Policy Recognition Form
- ❑ Section 3 Forms
 - Complete as applicable
- ❑ Certified Payroll (Weekly Reports) (Two page form with payroll on first page and statement of compliance on second page.)

Note: DuPage County Community Development Commission (CDC) is the DuPage County office responsible for administering HUD funds. This project is funded in whole or part via a grant of HUD funds from DuPage County to the Owner / Subgrantee.

Informational Materials Attached: Sample Labor Relations Agreement; Section 3 Initiative and Compliance summary; Instructions for Completing Certified Payrolls and Statement of Compliance; Categorizing Foremen, Supervisors, Owners, and Other Employees on Certified Payrolls; Sample Payroll; Sample Statement of Compliance.

HUD = United States Department of Housing and Urban Development

OWNERSHIP FORM

(To be completed by business owners)

Any contractor working on a federally funded project must be cleared through the Excluded Parties List System (EPLS) for identifying businesses and individuals that have been debarred or are otherwise ineligible to be paid with federal funds. Please complete this information so that such clearance may be performed by CDC staff.

PART 1 Business Information:

Legal Business Name			
Owner Name			
Address of Business			
Telephone #		DUNS #	
Webpage (if available)		FIN (IRS) #	
Trade(s)			

Indicate whether business is:

- Sole Proprietorship _____ Date Established: _____ BRC² _____
- Limited Liability Company _____
- Partnership _____ Date of Agreement: _____ BRC _____
- Corporation¹ _____ Date of Incorporation: _____ TIN³ _____

¹ Does not include affiliates, wholly owned subsidiaries or divisions.

² Business Registration Certificate Number

³ Tax Identification Number

Has the firm done or is it currently doing business under another name?

Yes: _____ No: _____

If yes, please provide the name and explain:

Is the spouse of the owner also involved in the business in any capacity (Vice President, secretary, etc)?

Yes: _____ No: _____

If yes, please provide name and the title of the spouse:

Identify the names of all owners/principals of the company:

Name	Title	Business Name (if applicable)

Is the firm in Good Standing with the State of Illinois? (This will be confirmed by CDC through a check of CyberDrive Illinois.)

Yes: _____ No: _____

If no, please explain:

PART 2 Other Concerns:

<input type="checkbox"/>	Business is owned by a minority person:	<input type="checkbox"/> African American	<input type="checkbox"/> Hispanic American
	<input type="checkbox"/> Other (Specify):	<input type="checkbox"/> Native American	<input type="checkbox"/> Asian/Pacific American

Business is woman owned.

I certify that the above information is complete and accurate.

Owner Signature Date

Print Name Title

**NOTIFICATION TO THE OFFICE OF FEDERAL
CONTRACT COMPLIANCE PROGRAMS (OFCCP)**

To be completed and mailed within 10 business days of contract signing. Send original to the Office of Federal Contract Compliance and photocopy to DuPage County Address at bottom of letter.

Date: _____

Michael Thomas, District Director
Office of Federal Contract Compliance Programs
U.S. Department of Labor – Employment Standards Administration
Chicago District Office
230 S. Dearborn St., Room 434
Chicago, IL 60604

Please be advised that the following contract in excess of \$10,000 has been awarded:

Program: _____

Contractor: _____

Contractor Address: _____

Contractor Telephone: _____

Contractor Employer ID Number: _____

\$ Amount of Contract: _____

Construction Start Date: _____

Construction Completion Date: _____

Project No. _____

Project Location: _____

Signed: _____

Printed Name: _____

Title: _____

CC: DuPage County Community Development
421 N. County Farm Rd, Room 3-100
Wheaton, IL 60187

CC: _____

Attn: _____

Attn: _____

CONTRACTOR/SUBCONTRACTOR LABOR RELATIONS AGREEMENT (LRA)

Project Name: Non-Profit Agency New Facility Construction; Project #: CD13-01; Project Address: 1 Main Street, Town, IL 60000; Contract Amount: 100,000; Contractor Name: Jones Construction Company; Type: Subcontractor; Address of Business: 123 Main Street, Town, IL 60000; Contact Person: Samuel Jones; Title: Owner/President; Telephone #: 111-111-1111; Fax #: 222-222-2222; Email Address: sam.jones@jonesco.com; FIN (IRS) #: 12-3456789

1. Is the contractor named above supplying materials only? [X] No (continue to question 2.) [] Yes (Material suppliers do not have to complete this form, but any labor subcontractors hired for installation of these materials must be disclosed and must complete all HUD forms.)

2. The following persons are hereby authorized to complete and sign all payroll forms and records for the above project:

Table with 4 columns: Name/Title, Signature, Name/Title, Signature. Row 1: Samuel Jones / Owner/President, Samuel Jones. Row 2: Jane Jones / Payroll Administrator, Jane Jones.

3. I [X] HAVE [] HAVE NOT received a copy of the applicable Davis-Bacon wage rates for the above project and I understand that Federal Prevailing Wage Rates apply to this project.

4. In the section below, please list the hourly wage and fringe benefits by job classification and group number of each trade employed by your company. Mark how benefits are paid. Total wages must meet Davis-Bacon minimums.

Job Classification # (for DuPage): CARP0555-005 (Building); Group # (if applicable): n/a; Hourly Wage Rate: \$41.52; Hourly Fringe Benefits: \$25.47; Fringe Benefits paid: [] in cash [X] into plan(s); TOTAL (wages + fringe): \$66.99

Job Classification # (for DuPage): LABO0002-003; Group # (if applicable): 1; Hourly Wage Rate: \$35.20; Hourly Fringe Benefits: \$21.45; Fringe Benefits paid: [] in cash [X] into plan(s); TOTAL (wages + fringe): \$56.65

Job Classification # (for DuPage): ; Group # (if applicable): ; Hourly Wage Rate: ; Hourly Fringe Benefits: ; Fringe Benefits paid: [] in cash [] into plan(s); TOTAL (wages + fringe): \$0.00

Job Classification # (for DuPage): ; Group # (if applicable): ; Hourly Wage Rate: ; Hourly Fringe Benefits: ; Fringe Benefits paid: [] in cash [] into plan(s); TOTAL (wages + fringe): \$0.00

Job Classification # (for DuPage): ; Group # (if applicable): ; Hourly Wage Rate: ; Hourly Fringe Benefits: ; Fringe Benefits paid: [] in cash [] into plan(s); TOTAL (wages + fringe): \$0.00

Job Classification # (for DuPage): ; Group # (if applicable): ; Hourly Wage Rate: ; Hourly Fringe Benefits: ; Fringe Benefits paid: [] in cash [] into plan(s); TOTAL (wages + fringe): \$0.00

WARNING: U.S. CRIMINAL CODE, SECTION 1010, TITLE 18, U.S.C., PROVIDES IN PART: "WHOEVER...MAKES, PASSES, UTTERS, OR PUBLISHES ANY STATEMENT, KNOWING THE SAME TO BE FALSE...SHALL BE FINED NOT MORE THAN \$5,000 OR IMPRISONED NOT MORE THAN TWO YEARS, OR BOTH."

The undersigned certifies that (s)he is an owner/officer of the contractor and further certifies compliance with all Federal EEO requirements:

CONTRACTOR/SUBCONTRACTOR LABOR RELATIONS AGREEMENT (LRA)

Project Name	Project Name	Project #	
Project Address		Contract Amount	
Contractor Name		Type	<input type="checkbox"/> GC <input type="checkbox"/> Subcontractor
<i>If SUBCONTRACTOR provide name of contracting company</i>			
Address of Business			
Contact Person		Title	
Telephone #		Fax #	
Email Address		FIN (IRS) #	

1. Is the contractor named above supplying materials only? No (continue to question 2.) Yes (Material suppliers do not have to complete this form, but any labor subcontractors hired for installation of these materials must be disclosed and must complete all HUD forms.)

2. The following persons are hereby authorized to complete and sign all payroll forms and records for the above project:

Name/Title:		Signature:	
Name/Title:		Signature:	

3. I HAVE HAVE NOT received a copy of the applicable Davis-Bacon wage rates for the above project and I understand that Federal Prevailing Wage Rates apply to this project.

4. In the section below, please list the hourly wage and fringe benefits by job classification and group number of each trade employed by your company. Mark how benefits are paid. Total wages must meet Davis-Bacon minimums.

Job Classification # (for DuPage)	
Group # (if applicable)	
Hourly Wage Rate:	
Hourly Fringe Benefits:	
<i>Fringe Benefits paid</i>	<input type="checkbox"/> in cash <input type="checkbox"/> into plan(s)
TOTAL (wages + fringe)	\$0.00

Job Classification # (for DuPage)	
Group # (if applicable)	
Hourly Wage Rate:	
Hourly Fringe Benefits:	
<i>Fringe Benefits paid</i>	<input type="checkbox"/> in cash <input type="checkbox"/> into plan(s)
TOTAL (wages + fringe)	\$0.00

Job Classification # (for DuPage)	
Group # (if applicable)	
Hourly Wage Rate:	
Hourly Fringe Benefits:	
<i>Fringe Benefits paid</i>	<input type="checkbox"/> in cash <input type="checkbox"/> into plan(s)
TOTAL (wages + fringe)	\$0.00

Job Classification # (for DuPage)	
Group # (if applicable)	
Hourly Wage Rate:	
Hourly Fringe Benefits:	
<i>Fringe Benefits paid</i>	<input type="checkbox"/> in cash <input type="checkbox"/> into plan(s)
TOTAL (wages + fringe)	\$0.00

Job Classification # (for DuPage)	
Group # (if applicable)	
Hourly Wage Rate:	
Hourly Fringe Benefits:	
<i>Fringe Benefits paid</i>	<input type="checkbox"/> in cash <input type="checkbox"/> into plan(s)
TOTAL (wages + fringe)	\$0.00

Job Classification # (for DuPage)	
Group # (if applicable)	
Hourly Wage Rate:	
Hourly Fringe Benefits:	
<i>Fringe Benefits paid</i>	<input type="checkbox"/> in cash <input type="checkbox"/> into plan(s)
TOTAL (wages + fringe)	\$0.00

WARNING: U.S. CRIMINAL CODE, SECTION 1010, TITLE 18, U.S.C., PROVIDES IN PART: "WHOEVER...MAKES, PASSES, UTTERS, OR PUBLISHES ANY STATEMENT, KNOWING THE SAME TO BE FALSE...SHALL BE FINED NOT MORE THAN \$5,000 OR IMPRISONED NOT MORE THAN TWO YEARS, OR BOTH."

The undersigned certifies that (s)he is an owner/officer of the contractor and further certifies compliance with all Federal EEO requirements:

Signature	Date
Print Name	Title

APPRENTICESHIP POLICY RECOGNITION FORM

This form has been provided by the DuPage Community Development Commission (CDC) for the contractor's benefit to fully understand the requirements that surround the use of apprentices and trainees on federally funded projects. You are encouraged by the CDC to assign apprentices to this project and this document discloses key requirements that will help contractors avoid infractions which necessitate wage restitution. By filling out this form, you are only demonstrating your awareness of the policies regarding apprentices and government work. After completing this form, please return it to the property owner to hand into to the CDC.

Project Name	Project Name	Project #	
Project Address		Contract Amount	
Contractor Name		Type	<input type="checkbox"/> GC <input type="checkbox"/> Subcontractor
<i>If SUBCONTRACTOR provide name of contracting company</i>			
Address of Business			
Contact Person		Title	
Telephone #		Fax #	
Email Address		FIN (IRS) #	

Federal regulations stipulate that apprentices and trainees (hereinafter "apprentices") assigned to a federally funded project are required to be accompanied by a qualified journeyman worker of the same trade. This means that apprentices are not to perform work on the *project* without proper supervision. Superintendents, company inspectors, managing supervisors, foremen, or any other person employed as contractor administration, do not qualify as a labor-mentoring agent. On each certified payroll, a journeyman's hours must match an apprentice's hours each day. There are no exceptions to this policy.

Should an apprentice perform work *alone* on the premises of the above stated project, Davis-Bacon Wage Determinations will apply and the apprentice must be paid the minimum prevailing wage for his or her time. Restitution must be paid to the employee in the manner of the difference between the prevailing wage and the apprentice's wage.

Do you plan on using apprentices for the above referenced project?	<input type="checkbox"/> Yes	<input type="checkbox"/> No
Are your apprentices registered with the Bureau of Apprenticeship and Training?	<input type="checkbox"/> Yes	<input type="checkbox"/> No

If not, you must register all apprentices with the Bureau. You can reach the local office at: (312) 596-5500. Return evidence of registration to the property owner.

List below the names and status of the apprentices likely planned for work on this project. Listing does not bind the contractor to assigning these apprentices and trainees:

Apprentice/Trainee Name	Year/Level	Registered	Wage/hour

I am now fully aware of the federal apprentice/trainee policies involving the above referenced project and will keep a copy of this disclaimer in the project file:

Signature	Date
Print Name	Title

DU PAGE COUNTY SECTION 3 INITIATIVE AND COMPLIANCE

Federal grant funds awarded by DuPage County to this project are subject to Section 3 compliance as provided in 24 CFR Part 135. The purpose of Section 3 is to ensure that employment and economic opportunities shall, to the greatest extent feasible, and consistent with existing Federal, State, and local laws and regulations, be directed to low-income persons and business concerns which provide opportunities for low-income persons. Section 3 designation is a person whose household income is 80% or less of area median family income (hereinafter, "low-income" or "Section 3 resident"). All contractors providing labor are subject to Section 3 and must complete the following documents (as applicable):

- 0) SECTION 3 CLAUSE: Acknowledgement to be signed by all Section 3 covered contractors (must be signed if the contract is over \$100,000).
- 1) FEDERAL SECTION 3 BUSINESS CONCERN SELF CERTIFICATION (FORM 1): To be completed by all contractors. Describes contractors' Section 3 status based on the following categories:
 - A. Business owned by Section 3 resident;
 - B. 30% of permanent full-time employees are Section 3 residents;
 - C. Subcontract 25% of award amount to Section 3 Business Concerns.
- 2) FEDERAL SECTION 3 RESIDENT SELF CERTIFICATION (FORM 2): To be completed by all business owners claiming Section 3 under category A and/or all Section 3 employees working on this project (Section 3 family income limits are included on the form);
- 3) PERMANENT EMPLOYEE / NEW HIRES LIST (FORM 3): To be completed by all business owners claiming Section 3 under category B or hiring new employees;
- 4) FEDERAL SECTION 3 BUSINESS CONCERN SUBCONTRACTING PLAN (FORM 4): To be completed by all business owners claiming Section 3 under category C;
- 5) FEDERAL SECTION 3 BUSINESS REPORTING (FORM 5): To be completed by all contractors. Information required to complete the federal reporting requirements.

DuPage County is responsible for executing compliance and reporting the outcomes of these efforts. Specifically, under this regulation, DuPage County is responsible for:

- 1) Informing any tier of subrecipients, developers, general contractors, contractors, and subcontractors of the requirements of Part 135;
- 2) Monitor the performance of all tiers in respect to the requirements and objectives of Part 135;
- 3) Notify potential contractors and subcontractors of Section 3 covered opportunities open for bid; and
- 4) Collect and report documentation in respect to all efforts made by tiers to achieve Section 3 participation.

Tiers receiving contracts greater than \$100,000 are covered by Section 3. As related to this project, and to the greatest extent feasible, these tiers are responsible for:

- 1) Contracting or hiring locally
- 2) Contracting at least 10% of the total project cost with Section 3 business concerns
 - a. Businesses which are majority owned by low-income persons qualify
 - b. Businesses which employ at least 30% full-time low-income employees qualify
 - c. Businesses which offer 25% of all subcontracts to Section 3 businesses qualify
- 3) Hiring, at least 30% of all new employees from low-income households
- 4) Refraining from entering into contracts with businesses in violation of Section 3
- 5) Documenting all efforts, actions taken, results, and/or impediments to achieving Section 3 obligations for submission to the DuPage Community Development Commission

Any tier contracting for \$100,000 or less is not responsible for complying with Section 3; however, it is encouraged that any contractor or new hire which qualifies as Section 3 be documented and reported to meet the numerical objectives as a whole.

Noncompliance involving the disregard of actions to be taken and/or documentation of those efforts, whether successful or not, may result in delayed or non-payment of Federal grant awards.

For more information about Section 3 and to access DuPage County's Section 3 certification forms, visit: http://www.dupageco.org/Community_Services/Community_Development_Commission/31074/

SECTION 3 CLAUSE

The requirements of Section 3 apply to contractors and subcontractors performing work on construction or rehabilitation projects for which the contract/subcontract amount exceeds \$100,000. Any tier contracting for \$100,000 or less is not required to comply; however, it is strongly encouraged.

TITLE 24 PART 135 ECONOMIC OPPORTUNITIES FOR LOW - AND VERY LOW - INCOME PERSONS 135.38 - Section 3 clause

All section 3 covered contracts shall include the following clause (referred to as the section 3 clause):

- A. The work to be performed under this contract is subject to the requirements of section 3 of the Housing and Urban Development Act of 1968, as amended, 12 U.S.C. 1701u (section 3). The purpose of section 3 is to ensure that employment and other economic opportunities generated by HUD assistance or HUD-assisted projects covered by section 3, shall, to the greatest extent feasible, be directed to low- and very low-income persons, particularly persons who are recipients of HUD assistance for housing.
- B. The parties to this contract agree to comply with HUD's regulations in 24 CFR part 135, which implement section 3. As evidenced by their execution of this contract, the parties to this contract certify that they are under no contractual or other impediment that would prevent them from complying with the part 135 regulations.
- C. The contractor agrees to send to each labor organization or representative of workers with which the contractor has a collective bargaining agreement or other understanding, if any, a notice advising the labor organization or workers' representative of the contractor's commitments under this section 3 clause, and will post copies of the notice in conspicuous places at the work site where both employees and applicants for training and employment positions can see the notice. The notice shall describe the section 3 preference, shall set forth minimum number and job titles subject to hire, availability of apprenticeship and training positions, the qualifications for each; and the name and location of the person(s) taking applications for each of the positions; and the anticipated date the work shall begin.
- D. The contractor agrees to include this section 3 clause in every subcontract subject to compliance with regulations in 24 CFR part 135, and agrees to take appropriate action, as provided in an applicable provision of the subcontract or in this section 3 clause, upon a finding that the subcontractor is in violation of the regulations in 24 CFR part 135. The contractor will not subcontract with any subcontractor where the contractor has notice or knowledge that the subcontractor has been found in violation of the regulations in 24 CFR part 135.
- E. The contractor will certify that any vacant employment positions, including training positions, that are filled (1) after the contractor is selected but before the contract is executed, and (2) with persons other than those to whom the regulations of 24 CFR part 135 require employment opportunities to be directed, were not filled to circumvent the contractor's obligations under 24 CFR part 135.
- F. Noncompliance with HUD's regulations in 24 CFR part 135 may result in sanctions, termination of this contract for default, and debarment or suspension from future HUD assisted contracts.
- G. With respect to work performed in connection with section 3 covered Indian housing assistance, section 7(b) of the Indian Self-Determination and Education Assistance Act (25 U.S.C. 450e) also applies to the work to be performed under this contract. Section 7(b) requires that to the greatest extent feasible (i) preference and opportunities for training and employment shall be given to Indians, and (ii) preference in the award of contracts and subcontracts shall be given to Indian organizations and Indian-owned Economic Enterprises. Parties to this contract that are subject to the provisions of section 3 and section 7(b) agree to comply with section 3 to the maximum extent feasible, but not in derogation of compliance with section 7(b).

The undersigned agrees to comply with the Section 3 Guidelines when applicable as referenced by HUD regulations in 24 CFR per 135 as amended.

Authorized Signature

Date

Print

Title

Business Name

Project #	
Date	

FEDERAL SECTION 3 BUSINESS CONCERN SELF CERTIFICATION (Form 1)

(To be completed by business owners)

PART 1 Business Concern Information:

Legal Business Name			
Address of Business			
Contact Person		Title	
Telephone #		Fax #	
Email Address		FIN (IRS) #	
Trade(s)			

Business Partners/Owners Name	Title	Address

PART 2 Section 3 Federal Business Concern: The above business certifies that it qualifies as a Section 3 Business Concern based on: *(Please check the appropriate category below and provide requested supporting forms)*

A Business is majority owned (at least 51%) by Section 3 Resident(s).
 Must provide signed *Federal Section 3 Resident Self Certification (Form 2)* for the owner(s)

or

B At least 30% of the permanent, full-time employees are currently Section 3 Residents or were Section 3 Residents within the past 3 years.
 Must provide *Permanent Employee / New Hire List (Form 3)*; and
 Must provide *Federal Section 3 Resident Self Certifications (Form 2)* for all owners and Section 3 employees

or

C Commitment to subcontract 25% of the dollar award to qualified Section 3 Business Concerns if awarded contract
 Must provide signed *Federal Section 3 Subcontracting Plan (Form 4)*; and
 Must provide signed *Federal Section 3 Business Concern Self Certifications (Form 1)* for all subcontractors

D Check "D" if none of the categories above apply to your business.

PART 3 Other Business Concern:

Business is owned by a minority person:

<input type="checkbox"/> African American	<input type="checkbox"/> Hispanic American
<input type="checkbox"/> Other (Specify):	<input type="checkbox"/> Native American
	<input type="checkbox"/> Asian/Pacific American

Business is woman owned.

PART 4 Business Owner Certification: This certification is valid for a period of 3 years (PLEASE READ CAREFULLY)

I authorize the information above to be added to a database of Section 3 Business Concerns that will enable my business to receive notice of contracting opportunities for future Section 3 covered projects. I understand that the Section 3 Business Concern list may provide additional employment opportunities, however inclusion on that list does not guarantee awarding of contracts. I further understand that this list may be accessed by DuPage County staff, developers and contractors working on Section 3 covered projects. **Yes** **No**

I certify that I will ensure that Section 3 information and its requirements are provided to all employees and lower tier subcontractors involved in the project. Under penalty of perjury I also certify that to the best of my knowledge and belief, data in this form and its attachments are true and correct, and the business will comply with all regulations and guidelines applicable to DuPage County's funding programs. I agree to furnish to DuPage County any requested documentation in support of verification of this self-certification. Furthermore, I acknowledge that this form is a public document subject to the Freedom of Information Act.

Owner Signature	Date
Print Name	Title

For CDC use only:

Project #	
Date	

FEDERAL SECTION 3 RESIDENT SELF CERTIFICATION (Form 2)

(To be completed by each business owner if claiming Section 3 under category A of Form 1 and/or all Section 3 employees/residents)

PART 1 Resident Information:

Name			
Home Address			
Telephone #		Email	
Name of Employer			

Job Category:	<input type="checkbox"/> Business Owner/Professional	<input type="checkbox"/> Office/Clerical
	<input type="checkbox"/> Technician	<input type="checkbox"/> Trade: _____

Employee Experience/ Training/ Job Skills:	
---	--

PART 2 Income Survey:

<i>How many persons live in your home?</i>	_____ persons
--	---------------

<i>What is the total yearly income of ALL persons, 18 years and older, living in your household?</i>	\$_____ total yearly household income
--	---------------------------------------

Note: Total yearly income means all funds (salaries, dividends, interest, etc.) received during the year, before taxes.

Please note that in order to qualify as a Section 3 Resident, the total yearly household income must be less than the 2017 Section 3 income limits listed below.

Persons in Household	1	2	3	4	5	6	7	8
80% AMI (gross income)	\$44,250	\$50,600	\$56,900	\$63,200	\$68,300	\$73,350	\$78,400	\$83,450

PART 3 Resident Certification: This certification is valid for a period of 3 years (PLEASE READ CAREFULLY)

I authorize the information above to be added to a database of Section 3 Residents that will enable me to receive notice of employment for future Section 3 covered projects. I understand the Section 3 Resident list may provide additional employment opportunities, however inclusion on that list does not guarantee employment. I further understand that this list may be accessed by DuPage County staff, developers and contractors working on Section 3 covered projects; however no personal information will be made available to the developers, contractors, or public. Yes No

Under penalty of perjury I certify that I, _____ (print name), am a legal resident of DuPage County and qualify as a Section 3 Resident because I meet the income limits as published on this form OR I am a public housing resident. I agree to furnish to DuPage County any requested documentation in support of verification of this self-certification.

Signature Date

Print Name

For CDC use only:

Project #	
Date	

PERMANENT EMPLOYEE / NEW HIRES LIST (Form 3)

(To be completed by business owners if claiming Section 3 under category B of Form 1 or business owners hiring new employees)

PART 1 Business Concern Information:

Legal Business Name			
Address of Business			
Contact Person		Title	
Telephone #		Fax #	
Email Address		FIN (IRS) #	

PART 2 List all full-time employees: (Attach additional sheets as needed.)

#	Employee Name	New Hire (yes/no)	Trade	Section 3 (yes/no)*
1.				
2.				
3.				
4.				
5.				
6.				
7.				
8.				
9.				
10.				
11.				
12.				
13.				
14.				
15.				
16.				
17.				
18.				
19.				
20.				

Total number of all employees:	
---------------------------------------	--

Have you, or do you, anticipate hiring new employees for this project?	<input type="checkbox"/> Yes	<input type="checkbox"/> No
---	------------------------------	-----------------------------

*** Provide Section 3 Resident Self Certification (Form 2) for all employees that qualify as Section 3 Residents. Please note that in order to qualify as a Section 3 Resident, the total yearly household income must be less than the 2017 Section 3 income limits listed below.**

Persons in Household	1	2	3	4	5	6	7	8
80% AMI (gross income)	\$44,250	\$50,600	\$56,900	\$63,200	\$68,300	\$73,350	\$78,400	\$83,450

PART 3 Certification: (PLEASE READ CAREFULLY)

Under penalty of perjury I certify that I am an owner/officer of the business and further certify that to the best of my knowledge and belief, data in this form and its attachments are true and correct, and the business will comply with all regulations and guidelines applicable to DuPage County's funding programs. I agree to furnish to DuPage County any requested documentation in support of verification of this form. Furthermore, I acknowledge that this form is a public document subject to the Freedom of Information Act.

	Date
	Title

For CDC use only:

Project #	
Date	

FEDERAL SECTION 3 BUSINESS CONCERN SUBCONTRACTING PLAN (Form 4)

(To be completed by business owners only if claiming Section 3 under category C of Form 1)

PART 1 Business Concern Information:

Legal Business Name			
Address of Business			
Contact Person		Title	
Telephone #		Fax #	
Email Address		FIN (IRS) #	

PART 2 Subcontractors:

Name of Subcontractor	Type of Contract (trade)	Estimated Contract Amount	Section 3 Business Concern (yes/no) *
1.			
2.			
3.			
4.			
5.			
6.			
7.			
8.			
9.			
10.			
11.			
12.			
13.			
14.			
15.			

* Provide Section 3 Business Concern Self Certification (Form 1) for all subcontractors that qualify as Section 3.

PART 3 Business Concern Contract and Subcontract(s) Amounts:

Total contract amount	\$	Estimated amount to be subcontracted	\$
Amount to be subcontracted to Section 3 businesses:	\$	% of subcontracts that are Section 3	%

PART 4 Certification: (PLEASE READ CAREFULLY)

Under penalty of perjury I certify that I am an owner/officer of the business and further certify that to the best of my knowledge and belief, data in this form and its attachments are true and correct, and the business will comply with all regulations and guidelines applicable to DuPage County's funding programs. I agree to furnish to DuPage County any requested documentation in support of verification of this form. Furthermore, I acknowledge that this form is a public document subject to the Freedom of Information Act.

Signature	Date
Print	Title

Project #	
Date	

FEDERAL SECTION 3 BUSINESS REPORTING (Form 5)

(To be completed by business owners - General Contractor & Subcontractors – only if awarded contract)

PART 1 Business Concern Information:

Please complete this form pertaining to the dollar amount your business has contracted for under this project.

Legal Business Name			
Address of Business			
Contact Person		Title	
Telephone #		Fax #	
Email Address		FIN (IRS) #	

Project Name		General or Subcontractor	
Contract Amount	\$	Number of Subs Hired	

PART 2 Employment and Training Data:

Please provide any employment and training figures concerning New Hires and Section 3 status:

Job category	Number of New Hires	Number of Section 3 New Hires	Number of Section 3 Trainees or Apprentices
Professionals			
Technicians			
Office/Clerical			
Construction Trade (Specify below):			
Other Categories (Specify below):			

PART 3 Contracting Data:

Construction Contracts:

Total dollar amount of your contract on this project:	\$
Total dollar amount subcontracted to Section 3 businesses:	\$
Percentage of total dollar amount subcontracted to Section 3 businesses:	
Total number of Section 3 Certified Businesses receiving contracts:	

Non-construction Contracts (engineering, architectural):

Total dollar amount of non-construction contracts received on this project:	\$
Total dollar amount subcontracted to non-construction Section 3 businesses:	\$
Percentage of total dollar amount subcontracted to non-construction Section 3 businesses:	
Total number of non-construction Section 3 businesses receiving contracts:	

PART 4 Certification: (PLEASE READ CAREFULLY)

Under penalty of perjury I certify that I am an owner/officer of the business and further certify that to the best of my knowledge and belief, data in this form and its attachments are true and correct, and the business will comply with all regulations and guidelines applicable to DuPage County's funding programs. I agree to furnish to DuPage County any requested documentation in support of verification of this form. Furthermore, I acknowledge that this form is a public document subject to the Freedom of Information Act.

Authorized Signature	Date
Print	Title

CATEGORIZING FOREMEN, SUPERVISORS, OWNERS, AND OTHER EMPLOYEES ON CERTIFIED PAYROLLS

Non-labor employees on or off the jobsite need not report their wage rates, however some exceptions do apply:

Non-Covered Job Classifications

Workers performing normal duties of the following job classifications are not subject to wage requirements:

- | | |
|---------------------------|------------------------------|
| 1) Project Superintendent | 5) Water Carrier |
| 2) Project Engineer | 6) Messenger |
| 3) Project Foreman* | 7) Clerical Workers |
| 4) Watchman | 8) Other Non-Labor Employees |

* Exception is the Working Foreman. A Working Foreman is one who devotes more than 20 percent of time during a work week to mechanic or labor duties, and who must be paid the applicable rate for the hours so worked.

Supervisors, Owners, and Other Salaried Employees Providing Full-Time Supervision

- 1) Supervisors
 - a. Hours worked by these employees must be reported although wage rates need NOT be reported.
 - b. The term "Salary" may appear in place of wage rate for any salaried employee.
- 2) Owners
 - a. Owners who perform labor-work on a federally funded project along side journeymen employees must also report hours worked.
 - b. Like supervisors owners need not report salary, with exception to #3:
- 3) Self-Employed, Sole-Laborer Owners
 - a. Owners who are either the only laborer or mentoring an apprentice or trainee MUST report wage rate and weekly wage for work performed.
 - b. Certified payrolls MUST also be completed and signed by the General Contractor.

Apprentices and Trainees

- 1) Apprentices and Trainees may be paid a lower wage rate than Prevailing Wage under the following conditions:
 - a. The apprentice or trainee is supervised hour for hour by a journeyman of the same trade.
 - b. Journeyman to apprentice ratio set by the local union is maintained
 - c. Supervisors, superintendents or any other management employee does not count as appropriate supervision.
- 2) If an apprentice or trainee is found unsupervised:
 - a. Employer will be contacted by phone and mail.
 - b. Restitution to meet the Davis-Bacon wage determination for hours worked will be required.
 - c. Non-compliance can and will hold up further payouts.

INSTRUCTIONS FOR COMPLETING PAYROLL FORM, WH-347

[WH-347](#) (PDF) OMB Control No. 1235-0008, Expires 01/31/2015.

General: Form WH-347 has been made available for the convenience of contractors and subcontractors required by their Federal or Federally-aided construction-type contracts and subcontracts to submit weekly payrolls. Properly filled out, this form will satisfy the requirements of Regulations, Parts 3 and 5 (29 C.F.R., Subtitle A), as to payrolls submitted in connection with contracts subject to the Davis-Bacon and related Acts.

While completion of Form WH-347 is optional, it is mandatory for covered contractors and subcontractors performing work on Federally financed or assisted construction contracts to respond to the information collection contained in 29 C.F.R. §§ 3.3, 5.5(a). The Copeland Act (40 U.S.C. § 3145) requires contractors and subcontractors performing work on Federally financed or assisted construction contracts to "furnish weekly a statement with respect to the wages paid each employee during the preceding week." U.S. Department of Labor (DOL) Regulations at 29 C.F.R. § 5.5(a)(3)(ii) require contractors to submit weekly a copy of all payrolls to the Federal agency contracting for or financing the construction project, accompanied by a signed "Statement of Compliance" indicating that the payrolls are correct and complete and that each laborer or mechanic has been paid not less than the proper Davis-Bacon prevailing wage rate for the work performed. DOL and federal contracting agencies receiving this information review the information to determine that employees have received legally required wages and fringe benefits.

Under the Davis-Bacon and related Acts, the contractor is required to pay not less than prevailing wage, including fringe benefits, as predetermined by the Department of Labor. The contractor's obligation to pay fringe benefits may be met either by payment of the fringe benefits to bona fide benefit plans, funds or programs or by making payments to the covered workers (laborers and mechanics) as cash in lieu of fringe benefits.

This payroll provides for the contractor to show on the face of the payroll all monies to each worker, whether as basic rates or as cash in lieu of fringe benefits, and provides for the contractor's representation in the statement of compliance on the payroll (as shown on page 2) that he/she is paying for fringe benefits required by the contract and not paid as cash in lieu of fringe benefits. Detailed instructions concerning the preparation of the payroll follow:

Contractor or Subcontractor: Fill in your firm's name and check appropriate box.

Address: Fill in your firm's address.

Payroll No.: Beginning with the number "1", list the payroll number for the submission.

For Week Ending: List the workweek ending date.

Project and Location: Self-explanatory.

Project or Contract No.: Self-explanatory.

Column 1 - Name and Individual Identifying Number of Worker: Enter each worker's full name and an individual identifying number (e.g., last four digits of worker's social security number) on each weekly payroll submitted.

Column 2 - No. of Withholding Exemptions: This column is merely inserted for the employer's convenience and is not a requirement of Regulations, Part 3 and 5.

Column 3 - Work Classifications: List classification descriptive of work actually performed by each laborer or mechanic. Consult classification and minimum wage schedule set forth in contract

specifications. If additional classifications are deemed necessary, see Contracting Officer or Agency representative. An individual may be shown as having worked in more than one classification provided an accurate breakdown or hours worked in each classification is maintained and shown on the submitted payroll by use of separate entries.

Column 4 - Hours worked: List the day and date and straight time and overtime hours worked in the applicable boxes. On all contracts subject to the Contract Work Hours Standard Act, enter hours worked in excess of 40 hours a week as "overtime".

Column 5 - Total: Self-explanatory

Column 6 - Rate of Pay (Including Fringe Benefits): In the "straight time" box for each worker, list the actual hourly rate paid for straight time worked, plus cash paid in lieu of fringe benefits paid. When recording the straight time hourly rate, any cash paid in lieu of fringe benefits may be shown separately from the basic rate. For example, "\$12.25/.40" would reflect a \$12.25 base hourly rate plus \$0.40 for fringe benefits. This is of assistance in correctly computing overtime. See "Fringe Benefits" below. When overtime is worked, show the overtime hourly rate paid plus any cash in lieu of fringe benefits paid in the "overtime" box for each worker; otherwise, you may skip this box. See "Fringe Benefits" below. Payment of not less than time and one-half the basic or regular rate paid is required for overtime under the Contract Work Hours Standard Act of 1962 if the prime contract exceeds \$100,000. In addition to paying no less than the predetermined rate for the classification which an individual works, the contractor must pay amounts predetermined as fringe benefits in the wage decision made part of the contract to approved fringe benefit plans, funds or programs or shall pay as cash in lieu of fringe benefits. See "FRINGE BENEFITS" below.

Column 7 - Gross Amount Earned: Enter gross amount earned on this project. If part of a worker's weekly wage was earned on projects other than the project described on this payroll, enter in column 7 first the amount earned on the Federal or Federally assisted project and then the gross amount earned during the week on all projects, thus "\$163.00/\$420.00" would reflect the earnings of a worker who earned \$163.00 on a Federally assisted construction project during a week in which \$420.00 was earned on all work.

Column 8 - Deductions: Five columns are provided for showing deductions made. If more than five deduction are involved, use the first four columns and show the balance deductions under "Other" column; show actual total under "Total Deductions" column; and in the attachment to the payroll describe the deduction(s) contained in the "Other" column. All deductions must be in accordance with the provisions of the Copeland Act Regulations, 29 C.F.R., Part 3. If an individual worked on other jobs in addition to this project, show actual deductions from his/her weekly gross wage, and indicate that deductions are based on his gross wages.

Column 9 - Net Wages Paid for Week: Self-explanatory.

Totals - Space has been left at the bottom of the columns so that totals may be shown if the contractor so desires.

Statement Required by Regulations, Parts 3 and 5: While the "statement of compliance" need not be notarized, the statement (on page 2 of the payroll form) is subject to the penalties provided by 18 U.S.C. § 1001, namely, a fine, possible imprisonment of not more than 5 years, or both. Accordingly, the party signing this statement should have knowledge of the facts represented as true.

Items 1 and 2: Space has been provided between items (1) and (2) of the statement for describing any deductions made. If all deductions made are adequately described in the "Deductions" column above, state "See Deductions column in this payroll." See "FRINGE BENEFITS" below for instructions concerning filling out paragraph 4 of the statement.

Item 4 FRINGE BENEFITS - Contractors who pay all required fringe benefits: If paying all fringe benefits to approved plans, funds, or programs in amounts not less than were determined in the applicable wage decision of the Secretary of Labor, show the basic cash hourly rate and overtime rate paid to each worker on the face of the payroll and check paragraph 4(a) of the statement on page 2 of the WH-347 payroll form to indicate the payment. Note any exceptions in section 4(c).

Contractors who pay no fringe benefits: If not paying all fringe benefits to approved plans, funds, or programs in amounts of at least those that were determined in the applicable wage decision of the Secretary of Labor, pay any remaining fringe benefit amount to each laborer and mechanic and insert in the "straight time" of the "Rate of Pay" column of the payroll an amount not less than the predetermined rate for each classification plus the amount of fringe benefits determined for each classification in the application wage decision. Inasmuch as it is not necessary to pay time and a half on cash paid in lieu of fringe benefits, the overtime rate shall be not less than the sum of the basic predetermined rate, plus the half time premium on basic or regular rate, plus the required cash in lieu of fringe benefits at the straight time rate. In addition, check paragraph 4(b) of the statement on page 2 the payroll form to indicate the payment of fringe benefits in cash directly to the workers. Note any exceptions in section 4(c).

Use of Section 4(c), Exceptions

Any contractor who is making payment to approved plans, funds, or programs in amounts less than the wage determination requires is obliged to pay the deficiency directly to the covered worker as cash in lieu of fringe benefits. Enter any exceptions to section 4(a) or 4(b) in section 4(c). Enter in the Exception column the craft, and enter in the Explanation column the hourly amount paid each worker as cash in lieu of fringe benefits and the hourly amount paid to plans, funds, or programs as fringe benefits. The contractor must pay an amount not less than the predetermined rate plus cash in lieu of fringe benefits as shown in section 4(c) to each such individual for all hours worked (unless otherwise provided by applicable wage determination) on the Federal or Federally assisted project. Enter the rate paid and amount of cash paid in lieu of fringe benefits per hour in column 6 on the payroll. See paragraph on "Contractors who pay no fringe benefits" for computation of overtime rate.

Public Burden Statement: We estimate that it will take an average of 55 minutes to complete this collection of information, including time for reviewing instructions, searching existing data sources, gathering and maintaining the data needed, and completing and reviewing the collection of information. If you have any comments regarding these estimates or any other aspect of this collection of information, including suggestions for reducing this burden, send them to the Administrator, Wage and Hour Division, ESA, U.S. Department of Labor, Room S3502, 200 Constitution Avenue, N.W., Washington, D.C. 20210.

Note: In order to view, fill out, and print PDF forms, you need Adobe® Acrobat® Reader® version 5 or later, which you may download for free at www.adobe.com/products/acrobat/readstep2.html. To save the completed forms on your workstation, you need to use the "Save As" method to save the file.

For example, move your mouse cursor over the PDF link and click on your "RIGHT" mouse button. This will cause a menu to be displayed, from which you will select the proper save option -- depending upon which browser you are using:

- For Microsoft IE users, select "Save Target As"
- For Netscape Navigator users, select "Save Link As"

Once you've selected the proper save option for your browser, and have saved the file to a location you specified, go to your program menu and start the Adobe Acrobat® Reader. Once open, locate the PDF file you saved and open it directly in Acrobat®.

PAYROLL



(For Contractor's Optional Use; See Instructions at www.dol.gov/whd/forms/wh347instr.htm)

Persons are not required to respond to the collection of information unless it displays a currently valid OMB control number.

Rev. Dec. 2008

NAME OF CONTRACTOR <input type="checkbox"/> OR SUBCONTRACTOR <input checked="" type="checkbox"/>		ADDRESS 123 Main Street, Town, IL 60000		OMB No.: 1235-0008 Expires: 01/31/2015
Jones Construction Company				
PAYROLL NO. 1 - initial	FOR WEEK ENDING 04/12/2013	PROJECT AND LOCATION Non-Profit Agency New Facility Construction, Town, IL	PROJECT OR CONTRACT NO. CD13-01	

(1) NAME AND INDIVIDUAL IDENTIFYING NUMBER (e.g., LAST FOUR DIGITS OF SOCIAL SECURITY NUMBER) OF WORKER	(2) NO OF WITHHOLDING EXEMPTIONS	(3) WORK CLASSIFICATION	O.T. OR ST.	(4) DAY AND DATE							(5) TOTAL HOURS	(6) RATE OF PAY	(7) GROSS AMOUNT EARNED	(8) DEDUCTIONS					(9) NET WAGES PAID FOR WEEK				
				S	M	T	W	T	F	S				FICA	WITH- HOLDING TAX	Union Dues	OTHER	TOTAL DEDUCTIONS					
				7	8	9	10	11	12	13				HOURS WORKED EACH DAY									
John Doe ###-##-1234 12 Any Street, Town, IL	2	CARPENTER JOURNEYMAN CARP0555-005	o									26.00	41.52	0.00	\$1,079.52	\$74.20	\$106.00	\$31.80			\$212.00	\$867.52	
				s	8.00	8.00	6.00	4.00															
John Doe ###-##-1234 12 Any Street, Town, IL	2	LABORER Group #1 LABO0002-003	o									14.00	35.20	0.00	\$492.80	\$34.50	\$49.28	\$13.55			\$97.33	\$395.47	
				s			2.00	4.00	8.00														
Thomas Terrific ###-##-5678 13 Any Street, Town, IL	1	CARPENTER APPRENTICE	o									14.00	30.50	0.00	\$427.00	\$29.89	\$64.05	\$12.81			\$106.75	\$320.25	
				s	8.00		6.00																
William Worker ###-##-9123 14 Any Street, Town, IL	2	LABORER Group #1 LABO0002-003	o			2.00		1.00				3.00	\$52.80		\$1,566.40	\$109.60	\$156.64	\$43.07			\$309.31	\$1,257.09	
				s	8.00	8.00	8.00	8.00	8.00														
James Smart ###-##-4567 15 Any Street, Town, IL	0	LABORER Group #1 LABO0002-003	o									40.00	35.20	21.45	\$2,266.00	\$158.62	\$453.20			\$611.82	\$1,654.18		
				s	8.00	8.00	8.00	8.00	8.00														
Samuel Jones ###-##-8912 16 Any Street, Town, IL	0	OWNER	o									16.00											
				s	8.00	8.00																	

While completion of Form WH-347 is optional, it is mandatory for covered contractors and subcontractors performing work on Federally financed or assisted construction contracts to respond to the information collection contained in 29 C.F.R. §§ 3.3, 5.5(a). The Copeland Act (40 U.S.C. § 3145) contractors and subcontractors performing work on Federally financed or assisted construction contracts to "furnish weekly a statement with respect to the wages paid each employee during the preceding week." U.S. Department of Labor (DOL) regulations at 29 C.F.R. § 5.5(a)(3)(i) require contractors to submit weekly a copy of all payrolls to the Federal agency contracting for or financing the construction project, accompanied by a signed "Statement of Compliance" indicating that the payrolls are correct and complete and that each laborer or mechanic has been paid not less than the proper Davis-Bacon prevailing wage rate for the work performed. DOL and federal contracting agencies receiving this information review the information to determine that employees have received legally required wages and fringe benefits.

Public Burden Statement

We estimate that it will take an average of 55 minutes to complete this collection, including time for reviewing instructions, searching existing data sources, gathering and maintaining the data needed, and completing and reviewing the collection of information. If you have any comments regarding these estimates or any other aspect of this collection, including suggestions for reducing this burden, send them to the Administrator, Wage and Hour Division, U.S. Department of Labor, Room S3502, 200 Constitution Avenue, N.W. Washington, D.C. 20355.

PAYROLL

(For Contractor's Optional Use; See Instructions at www.dol.gov/whd/forms/wh347instr.htm)



Rev. Dec. 2008

Persons are not required to respond to the collection of information unless it displays a currently valid OMB control number.

OMB No.: 1235-0008
Expires: 01/31/2015

NAME OF CONTRACTOR <input type="checkbox"/> OR SUBCONTRACTOR <input type="checkbox"/>	ADDRESS	OMB No.: 1235-0008 Expires: 01/31/2015	
PAYROLL NO.	FOR WEEK ENDING	PROJECT AND LOCATION	PROJECT OR CONTRACT NO.

(1) NAME AND INDIVIDUAL IDENTIFYING NUMBER (e.g., LAST FOUR DIGITS OF SOCIAL SECURITY NUMBER) OF WORKER	(2) NO OF WITHHOLDING EXEMPTIONS	(3) WORK CLASSIFICATION	OT. OR ST.	(4) DAY AND DATE							(5) TOTAL HOURS	(6) RATE OF PAY	(7) GROSS AMOUNT EARNED	(8) DEDUCTIONS					(9) NET WAGES PAID FOR WEEK
				HOURS WORKED EACH DAY										FICA	WITH- HOLDING TAX	OTHER	TOTAL DEDUCTIONS		
			O																
			S																
			O																
			S																
			O																
			S																
			O																
			S																
			O																
			S																
			O																
			S																
			O																
			S																

While completion of Form WH-347 is optional, it is mandatory for covered contractors and subcontractors performing work on Federally financed or assisted construction contracts to respond to the information collection contained in 29 C.F.R. §§ 3.3, 5.5(a). The Copeland Act (40 U.S.C. § 3145) contractors and subcontractors performing work on Federally financed or assisted construction contracts to "furnish weekly a statement with respect to the wages paid each employee during the preceding week." U.S. Department of Labor (DOL) regulations at 29 C.F.R. § 5.5(a)(3)(i) require contractors to submit weekly a copy of all payrolls to the Federal agency contracting for or financing the construction project, accompanied by a signed "Statement of Compliance" indicating that the payrolls are correct and complete and that each laborer or mechanic has been paid not less than the proper Davis-Bacon prevailing wage rate for the work performed. DOL and federal contracting agencies receiving this information review the information to determine that employees have received legally required wages and fringe benefits.

Public Burden Statement

We estimate that it will take an average of 55 minutes to complete this collection, including time for reviewing instructions, searching existing data sources, gathering and maintaining the data needed, and completing and reviewing the collection of information. If you have any comments regarding these estimates or any other aspect of this collection, including suggestions for reducing this burden, send them to the Administrator, Wage and Hour Division, U.S. Department of Labor, Room S3502, 200 Constitution Avenue, N.W. Washington, D.C. 20036 **Federal Requirements**

NOT FOR BID

Federal Wage Decision

(will be provided to you for inclusion in the Bid Specification Manual at the time the Manual is approved by CDC staff)

Please be advised, the included federal wage decision is being provided as a courtesy. The federal wage decisions are updated weekly and the most current versions can be obtained at www.wdol.gov

This wage decision is subject to change pending modification by the Department of Labor. The actual wages that must be paid will be "locked" at bid opening based on the most current wage decision, and provided a contract is awarded within 90 days of bid opening, and construction is started within 90 days of contract award.

NOT FOR BID

General Decision Number: IL180011 06/08/2018 IL11

Superseded General Decision Number: IL20170011

State: Illinois

Construction Types: Heavy and Highway

Counties: Boone, De Kalb, Du Page, Kane, Kendall, Lake, McHenry and Will Counties in Illinois.

HEAVY AND HIGHWAY CONSTRUCTION PROJECTS (does not include landscape projects).

Note: Under Executive Order (EO) 13658, an hourly minimum wage of \$10.35 for calendar year 2018 applies to all contracts subject to the Davis-Bacon Act for which the contract is awarded (and any solicitation was issued) on or after January 1, 2015. If this contract is covered by the EO, the contractor must pay all workers in any classification listed on this wage determination at least \$10.35 per hour (or the applicable wage rate listed on this wage determination, if it is higher) for all hours spent performing on the contract in calendar year 2018. The EO minimum wage rate will be adjusted annually. Please note that this EO applies to the above-mentioned types of contracts entered into by the federal government that are subject to the Davis-Bacon Act itself, but it does not apply to contracts subject only to the Davis-Bacon Related Acts, including those set forth at 29 CFR 5.1(a)(2)-(60). Additional information on contractor requirements and worker protections under the EO is available at www.dol.gov/whd/govcontracts.

Modification Number	Publication Date
0	01/05/2018
1	04/06/2018
2	05/11/2018
3	05/25/2018
4	06/01/2018
5	06/08/2018

CARP0555-003 06/01/2017

DUPAGE ANE LAKE COUNTIES

	Rates	Fringes
CARPENTER		
Building.....	\$ 46.35	31.29
Heavy & Highway.....	\$ 46.35	31.31

CARP0555-008 06/01/2016

WILL COUNTY

	Rates	Fringes
Carpenter and Piledriver.....	\$ 45.35	32.30

CARP0555-011 06/01/2017

KANE, McHENRY (North of Hwy 52), AND KENDALL COUNTIES

	Rates	Fringes
Carpenter and Piledriver.....	\$ 46.35	31.30

CARP0790-003 05/01/2018		

DE KALB COUNTY

	Rates	Fringes
CARPENTER.....	\$ 41.77	29.18

CARP0790-004 05/01/2018		

CARROLL, JO DAVIESS, LEE, OGLE (Oregon and South thereof), STEPHENSON, and WHITESIDE COUNTIES

	Rates	Fringes
CARPENTER.....	\$ 41.77	29.18

CARP0792-003 05/01/2018		

BOONE COUNTY

	Rates	Fringes
CARPENTER.....	\$ 44.22	26.73

ELEC0009-002 06/04/2017		

WILL COUNTY

	Rates	Fringes
Line Construction		
Groundman.....	\$ 39.39	61.37%
Lineman and Equipment		
Operator.....	\$ 50.50	61.37%

ELEC0117-001 05/29/2017		

KANE (Northern Half) and McHENRY (All) COUNTIES

	Rates	Fringes
ELECTRICIAN.....	\$ 47.29	31.40

ELEC0150-001 07/01/2017		

LAKE COUNTY

	Rates	Fringes
ELECTRICIAN.....	\$ 40.00	38.49

ELEC0176-011 06/01/2017		

WILL COUNTY

	Rates	Fringes
ELECTRICIAN.....	\$ 42.50	37.61

ELEC0196-001 03/05/2018

BOONE, DEKALB, DUPAGE, KANE, KENDALL, LAKE, and MCHENRY COUNTIES

	Rates	Fringes
Line Construction		
Equipment Operator.....	\$ 42.59	32.75%+\$5.75+A
Groundman.....	\$ 32.86	32.75%+\$5.75+A
Lineman, Substation Technician, Cable Splicing Technician, Digger Operator, Crane Opertor 20 tons and above, and Signal Technician.....	\$ 51.06	32.75%+\$5.75+A

FOOTNOTE: A. PAID HOLIDAYS: Memorial Day, Independence Day, Labor Day, and Thanksgiving Day

ELEC0364-003 06/01/2018

BOONE (All) & DEKALB (Remainder) COUNTIES

	Rates	Fringes
ELECTRICIAN.....	\$ 47.00	33.51

ELEC0461-006 05/29/2017

DEKALB (Sandwich TWP), KANE (Southern Half) & KENDALL (All) COUNTIES

	Rates	Fringes
ELECTRICIAN.....	\$ 47.72	29.84

ELEC0701-001 05/29/2017

DUPAGE COUNTY

	Rates	Fringes
ELECTRICIAN.....	\$ 39.26	101.99%

ENGI0150-015 06/01/2017

BOONE and DE KALB COUNTIES

	Rates	Fringes
OPERATOR: Power Equipment		
Group 1.....	\$ 45.65	35.90
Group 2.....	\$ 45.10	35.90
Group 3.....	\$ 43.80	35.90
Group 4.....	\$ 42.35	35.90
Group 5.....	\$ 40.90	35.90

POWER EQUIPMENT OPERATOR CLASSIFICATIONS

GROUP 1: Asphalt Plant; Asphalt Heater and Planer combination; Asphalt Spreader; Asphalt Silo Tender; Autograder, GOMACO or similar; Belt Loader; Caisson Rigs; Car Dumper, Central Redi-Mix Plant; Combination Backhoe

Front End Loader Machine (1 cu yd or over Backhoe bucket with attachments); Backhoe with Shear attachment; Concrete Breaker (truck mounted); Concrete Conveyor; Concrete Paver over 27E cu ft; Concrete Placer; Concrete Tube Float; Cranes, all attachments; Cranes, Hammerhead, Linden, Peco and machines of a like nature; Creter Crane; Crusher, stone; Derricks; Derrick Boats; Derricks, traveling; Dredges; Field Mechanic Welder; Formless Curb and Gutter Machine; Gradall and machines of a like nature; Grader, Elevating; Grader, Motor Grader, Motor Patrol, Auto Patrol, Form Grader, Pull Grader, Subgrader; Guard Rail Post Driver mounted; Hoists, one, two, and three Drum; Hydraulic Backhoes; Locomotive, all Mucking Machine; Pile Drivers and Skid Rig; Pre-Stress Machine; Pump Cretes Dual Ram; Rock Drill-Crawler or Skid Rig; Rock Drill truck mounted; Roto Mill Grinder, 36" and over; Roto Mill Grinder, less than 36"; Slip- Form Paver; Soil Test Drill Rig, truck mounted; Straddle Buggies; GCI Crane and similar; Hydraulic Telescoping Form (tunnel); Tie Back MACHINE; Tractor Drawn Belt Loader: Tractor Drawn Belt Loader with attached Pusher; Tractor with boom; Tractaire with attachment; Traffic Barrier Conveyor Machine; Raised or Blind Hoe Drill (Tunnel & Shaft); Trenching Machine; Truck Mounted Concrete Pump with boom; Truck mounted Concrete Conveyor; Underground Boring and/or Mining Machines under 5 ft; Wheel Excavator & Widener (Apsco)

GROUP 2: Batch Plant; Bituminous Mixer; Bobcats over .75 cu yd; Boiler and Throttle Valve; Bulldozer; Car Loader Trailing Conveyors; Combination Backhoe Front End Loader Machine, less than 1 cu yd Backhoe Bucket with attachments; Compressor and Throttle Valve; Compressor, common receiver (3); Concrete Breaker or Hydro Hammer; Concrete Grinding Machine; Concrete Mixer or Paver 75 series to and including 27 cu ft; Concrete Spreader; Concrete Curing Machine, Burlap Machine; Belting Machine and Sealing Machine; Conveyor Muck Cars (Haglund or similar type); Finishing Machine-Concrete; Greaser Engineer; Highlift Shovels or Front End Loader; Hoist-Sewer Dragging Machine; Hydraulic Boom Trucks, all attachments; Locomotives, Dinky; Pump Cretes, Squeeze Cretes-Screw Type pumps, Gypsum Bulker and Pump; Roller Asphalt; Rotary Snow Plows; Rototiller, Seaman, etc self-Propelled; Scoops-Tractor Drawn; Self-propelled Compactor; Spreader-Chip- Stone etc; Scraper; Scraper-Prime Mover in Tandem regardless of size (add \$1.00 to to Group 2 hourly rate for each hour and for each machine attached thereto); Tank Car Heater; Tractors, Push, pulling Sheeps Foot, Disc, or Compactor, etc; Tug Boats

GROUP 3: Boilers; Brooms, all power propelled; Cement Supply Tender; Compressor, Common Receiver (2); Concrete Mixer, two bag and over; Conveyor, Portable; Farm type Tractors used for mowing, seeding, etc; Fireman on Boilers; Forklift Trucks; Grouting Machines; Hoists, Automatic; Hoists, all Elevators; Hoists, Tugger single Drum; Jeep Diggers; Pipe Jacking Machines; Post- hole Digger; Power Saw, Concrete, Power Driven; Pug Mills; Rollers, other than asphalt; Seed and Straw Blower; Steam Generators; Stump Machine; Winch Trucks with A-Frame; Work Boats; Tamper-Form motor driven

GROUP 4: Air compressor - Small 185 and under (1 to 5 not to exceed a total of 300 ft); Air Compressor - Large over 185; Asphalt Spreader Backend Man; Combination - Small Equipment Operator; Generators - Small 50 kw and under; Generators -

Large , over 50 kw; Heaters, Mechanical; Hydraulic power unit (Pile Driving, Extracting or Drilling); Light Plants All (1 to 5); Pumps, over 3" (1 to 3, not to exceed a total of 300 ft); Pumps, Well Points; Tractaire; Welding Machines (2 through 5); Winches, 4 small electric drill winches; Bobcats up to and including .75 cu yd

GROUP 5: Oilers

PREMIUM PAY:

Long Boom :

Cranes & Derricks 90' to 150' including jib receive an extra \$.50 per hour. Cranes & Derricks over 150' including jib receive an extra \$.50 per hour plus an additional \$.10 for each additional 10' of boom or jib.

Capacity Pay: Cranes & Derricks with maximum capacity exceeding 50 ton with less than 90' of boom or jib shall be compensated \$.01 per hour for each ton of the rated capacity in excess of 50 ton.

Long Boom pay and Capacity pay cannot be combined.

Crane mounted earth auger, raised and blind hole drills, and truck mounted drill rigs receive an extra \$.50 per hour.

Creter Cranes:

When the Creter Crane is equipped with a conveyor system capable of extending 70' or more, the engineer shall receive an extra \$.50 per hour.

Truck Mounted Concrete Pumps:

When the Truck Mounted Concrete Pump is equipped with a boom, which is capable of extending 90' or more, the engineer shall receive \$.50 per hour extra.

Truck Mounted Concrete Conveyor:

Truck Mounted Concrete Conveyors equipped with conveyors that are capable of extending 90' or more, the engineer shall receive an extra \$.50 per hour.

Underground Work:

Employees working in tunnels, shafts, etc. shall be paid an additional \$.40 per hour. Employees working under air pressure 1/2 pound to 7 pounds shall receive an additional \$.50 per hour. Employees working under air pressure of 7 pounds or over shall receive \$.65 per hour more.

Mining Machines- Boring Machines:

The crew operating and maintaining the Mining Machines shall be compensated an additional \$.50 per hour.

* ENGI0150-024 06/01/2018

DUPAGE, KANE, KENDALL, LAKE, McHENRY, and WILL COUNTIES

	Rates	Fringes
OPERATOR: Power Equipment		
GROUP 1.....	\$ 49.30	38.15
GROUP 2.....	\$ 48.75	38.15
GROUP 3.....	\$ 46.70	38.15
GROUP 4.....	\$ 45.30	38.15

GROUP 5.....\$ 44.10

38.15

POWER EQUIPMENT OPERATOR CLASSIFICATIONS

GROUP 1: Asphalt Plant*; Asphalt Heater and Planer combination; Asphalt Heater Scarfire*, Asphalt Spreader; Autograder/ GOMACO or similar; ABG Paver*, Backhoes with Caisson attachment*, Ballast Regulator, Belt Loader*; Caisson Rigs*Car Dumper, Central Redi-Mix Plant*, Combination Backhoe; Front End Loader Machine (1 cu yd or over Backhoe bucket or with attachments); Concrete Breaker (truck mounted); Concrete Conveyor; Concrete Paver over 27E cu ft*; Concrete Placer*; Concrete Tube Float; Cranes, all attachments*; Cranes, Hammerhead, Linden, Peco and machines of a like nature*; Creter Crane; Crusher, stone; All Derricks; Derrick Boats; Derricks, traveling*; Dowell Machine with Air Compressor (\$1.00 above Class 1); Dredges*; Field Mechanic Welder; Formless Curb and Gutter Machine*; Gradall and machines of a like nature*; Grader, Elevating; Grader, Motor Grader, Motor Patrol, Auto Patrol, Form Grader, Pull Grader, Subgrader; Guard Rail Post Driver mounted*; Hoists, one, two, and three Drum; Hydraulic Backhoes*; Backhoes with Shear attachments*; Mucking Machine; Pile Drivers and Skid Rig*; Pre-Stress Machine; Pump Cretes Dual Ram (requires frequent lubrication and water)*; Rock Drill- Crawler or Skid Rig*; Rock Drill truck mounted*; Rock/ Track Tamper; Roto Mill Grinder, (36" and over)*; Slip-Form Paver*; Soil Test Drill Rig, truck mounted*; Straddle Buggies; Hydraulic Telescoping Form (tunnel); Tractor Drawn Belt Loader*; Tractor Drawn Belt Loader with attached Pusher (two engineers); Tractor with boom; Tractaire with attachment; Traffic Barrier Transfer Machine*; Trenching Machine; Truck Mounted Concrete Pump with boom*; Underground Boring and/or Mining Machines 5 ft in diameter and over tunnel, etc.*; Wheel Excavator* & Widener (Apsco); Raised or Blind Hoe Drill, Tunnel & Shaft*

GROUP 2: Batch Plant*; Bituminous Mixer; Boiler and Throttle Valve; Bulldozer; Car Loader Trailing Conveyors; Combination Backhoe Front End Loader Machine, (less than 1 cu yd Backhoe Bucket with attachments); Compressor and Throttle Valve; Compressor, common receiver (3); Concrete Breaker or Hydro Hammer; Concrete Grinding Machine; Concrete Mixer or Paver 75 series to and including 27 cu ft; Concrete Spreader; Concrete Curing Machine; Burlap Machine; Belting Machine and Sealing Machine; Concrete Wheel Saw; Conveyor Muck Cars (Haglund or similar type); Drills (all); Finishing Machine-Concrete; Greaser Engineer; Highlift Shovels or Front End Loader; Hoist- Sewer Dragging Machine; Hydraulic Boom Trucks, all attachments; Hydro-Blaster (requires two operators); Laser Screed*; Locomotives, Dinky; Off-Road Hauling Units (including articulating); Pump Cretes; Squeeze Cretes-Screw Type pumps, Gypsum Bulker and Pump; Roller Asphalt; Rotary Snow Plows; Rototiller, Seaman, self-Propelled; Scoops-Tractor Drawn; Self-propelled Compactor; Spreader-Chip-Stone; Scraper; Scraper-Prime Mover in Tandem regardless of size (add \$1.00 to Group 2 hourly rate for each hour and for each machine attached thereto add \$1.00 to Group 2 hourly rate for each hour); Tank Car Heater; Tractors, Push, pulling Sheeps Foot, Disc, or Compactor, etc; Tug Boats

GROUP 3: Boilers; Brooms, all power propelled; Cement Supply Tender; Compressor, Common Receiver (2); Concrete Mixer, two bag and over; Conveyor, Portable; Farm type Tractors

used for mowing, seeding, etc; Fireman on Boilers; Forklift Trucks; Grouting Machines; Hoists, Automatic; Hoists, all Elevators; Hoists, Tugger single Drum; Jeep Diggers; Low Boys; Pipe Jacking Machines; Post-hole Digger; Power Saw, Concrete, Power Driven; Pug Mills; Rollers, other than asphalt; Seed and Straw Blower; Steam Generators; Stump Machine; Winch Trucks with A-Frame; Work Boats; Tamper-Form motor driven

GROUP 4: Air compressor - Small 250 and under (1 to 5 not to exceed a total of 300 ft); Air Compressor - Large over 250; Combination - Small Equipment Operator; Directional Boring Machine; Generators - Small 50 kw and under; Generators - Large , over 50 kw; Heaters, Mechanical; Hydraulic power unit (Pile Driving, Extracting or Drilling); Light Plants (1 to 5); Pumps, over 3" (1 to 3, not to exceed a total of 300 ft); Pumps, Well Points; Tractaire; Welding Machines (2 through 5); Winches, 4 small electric drill winches;

GROUP 5: Bobcats (All); Brick Forklifts; Oilers; Directional Boring

*Requires Oiler

IRON0001-014 06/01/2017

DU PAGE (Eastern 1/4), LAKE, AND MCHENRY (Hebron, Woodstock, and East thereof) COUNTIES

	Rates	Fringes
IRONWORKER		
Sheeter.....	\$ 47.58	37.34
Structural and Reinforcing..	\$ 47.33	37.34

IRON0063-003 06/01/2017

LAKE, DUPAGE (Eastern 1/4) and MCHENRY (HEBRON, WOODSTOCK & EAST THEREOF) COUNTIES

	Rates	Fringes
IRONWORKER, ORNAMENTAL.....	\$ 46.75	34.44

IRON0393-003 06/01/2017

DEKALB (SOUTHEASTERN 2/3 including Sycamore and Dekalb), DUPAGE (REMAINDER), KANE, KENDALL (NORTHERN PART), and MCHENRY (SOUTHEAST 1/4) COUNTIES

	Rates	Fringes
IRONWORKER.....	\$ 45.61	34.98

IRON0444-006 06/01/2017

KENDALL (Southern Part) and WILL COUNTIES

	Rates	Fringes
IRONWORKER.....	\$ 42.50	36.70

IRON0498-003 06/01/2017

BOONE, DEKALB (EXCEPT Southeast), and MCHENRY (Northwest)
COUNTIES

	Rates	Fringes
IRONWORKER.....	\$ 38.33	37.44

LAB00002-004 06/01/2017

DUPAGE COUNTY

	Rates	Fringes
LABORER (SEWER CONSTRUCTION)		
GROUP 1.....	\$ 41.20	27.47
GROUP 2.....	\$ 41.33	27.47
GROUP 3.....	\$ 41.43	27.47
GROUP 4.....	\$ 41.55	27.47
GROUP 5.....	\$ 41.20	27.47

LABORER CLASSIFICATIONS

GROUP 1: Signalmen Top Laborers, and all other Laborers not
Mentioned.

GROUP 2: Concrete Laborers; Steel Setters.

GROUP 3: Cement Carriers; Cement Mixers; Concrete Repairmen;
Mortar Men; Scaffold Men; and Second Bottom Men.

GROUP 4: Bottom Men; Bracers-Bracing; Bricklayer's Tender;
Catch Basin Digger; Drainlayer; Dynamiter; Form Men;
Jackhammermen; Powerpac; Pipelayers; Rodders; Welders &
Burners; Well Point System Men.

GROUP 5: Asbestos Abatement Laborers, Toxic and Hazardous
Waste Removal Laborers & Dosimeter use (any device)
Monitoring Nuclear Exposure.

LAB00002-009 06/01/2017

DU PAGE COUNTY

	Rates	Fringes
LABORER (Compressed Air)		
0 - 15 lbs.....	\$ 42.20	27.47
16 - 20 lbs.....	\$ 42.70	27.47
21 - 26 lbs.....	\$ 43.20	27.47
27 - 33 lbs.....	\$ 44.20	27.47
34 lbs and over.....	\$ 45.20	27.47
LABORER (Tunnel and Sewer)		
GROUP 1.....	\$ 41.20	27.47
GROUP 2.....	\$ 41.33	27.47
GROUP 3.....	\$ 41.43	27.47
GROUP 4.....	\$ 41.55	27.47
GROUP 5.....	\$ 41.20	27.47

LABORER CLASSIFICATIONS (TUNNEL)

GROUP 1: Cage tenders; Dumpmen; Flagmen; Signalmen; Top laborers

GROUP 2: Air hoist operator; Key board operator; concrete laborer; Grout; Lock tenders (Free Air Side); Steel setters; Tuggers; Switchmen; Car pusher

GROUP 3: Concrete repairmen; Lock tenders (pressure side); Mortar men; Muckers; Grout machine operators; Track layers

GROUP 4: Air trac drill operator; Miner; Bricklayer tenders; Concrete blower operator; Drillers; Dynamiters; Erector operator; Form men; Jackhammermen; Powerpac; Mining machine operators; Mucking machine operator; Laser beam operator; Liner plate and ring setters; Shield drivers; Power knife operator; Welder- burners; Pipe jacking machine operator; skimmers; Maintenance technician

GROUP 5: Asbestos abatement laborer; Toxic and hazardous waste removal laborer; Dosimeter (any device) monitoring nuclear exposure

LABORER CLASSIFICATIONS (SEWER)

GROUP 1: Signalmen; Top laborers and All other laborers

GROUP 2: Concrete laborers and Steel setters

GROUP 3: Cement carriers; Cement mixers; Concrete repairmen; Mortar men; Scaffold men; Second Bottom men

GROUP 4: Air trac drill operator; Bottom men; Bracers-bracing; Bricklayer tenders; Catch basin diggers; Drainlayers; dynamiters; Form men; Jackhammermen; Powerpac; Pipelayers; Rodders; Welder-burners; Well point systems men

GROUP 5: Asbestos abatement laborer, Toxic and hazardous waste removal laborer; Dosimeter (any device) monitoring nuclear exposure

LAB00032-007 05/01/2018

DE KALB COUNTY

	Rates	Fringes
LABORER		
General Laborer.....	\$ 35.40	31.73
Skilled Laborer.....	\$ 38.25	31.73

LABORER CLASSIFICATIONS

General Laborer: Carpenter Tender, Tool Cribman, Fireman or Salamander Tender, Flagman, Gravel Box Man, Bumpman & Spotter, Form Handler, Material Handler, Fencing Laborer, Cleaning Lumber, Pit Man, Material Checker, Landscaper, Unloading Explosives, Laying of Sod, Planting of Trees, Asphalt Workers With Machine & Layers, Asphalt Plant Laborer, Wrecking, Fire-proofing, Driving Stakes, Stringlines for All Machinery, Window Cleaning, Demolition Worker, Explosive Handling, Trimming & Removal of Trees, Multi-Plate Pipe, Pilot Cars for Traffic Control, Power Rigging

Skilled Laborer: Asbestos Abatement Worker; Hazardous Waste Worker Handling any Materials with any Foreign Matter Harmful to Skin or Clothing, Track Labor, Cement Handler, Chloride Handler, Unloading & Laborers with Steel Workers & Re-bars, Wet Concrete Workers, Tunnel Tenders in Free Air, Batch Dumper, Mason Tender, Kettle & Tar Man, Tank Cleaner, Plastic Installer, Scaffold Worker, Motorized Buggies or Motorized Unit Used For Wet Concrete or Handling of Building Materials, Laborers With De-Watering Systems, Sewer Workers Plus Depth, Vibrator Operator; Cement Silica, Clay, Fly Ash, Lime & Plasters Handlers (Bulk or Bag); Cofferdam Worker Plus Depth, Concrete Paving, Placing, Cutting & Tying of Reinforcing, Deck Hand, Dredge Hand and Shore Laborer, Bankman on Floating Plant, Grade Checker, Power Tools, Front End Man on Chip Spreader, Caisson Worker Plus Depth, Gunnite Nozzleman, Leadman on Sewer Work, Welder, Cutter, Burner & Torchman, Chain Saw Operator, Jackhammer & Drill Operator, Layout Man and/or Tile Layer, Steel Form Setter - Street & Highway, Air Tamping Hammerman, Signal Man On Crane, Concrete Saw Operator, Screenman on Asphalt Paver, Tending Masons with Hot Material or Where Foreign Materials are used, Mortar Mixer Operator, Multiple Concrete Duct - Leadman, Luteman, Asphalt Raker Curb Asphalt Machine Operator, Ready Mix Scaleman Permanent Portable or Temporart Plant, Laborer Handling Masterplate or Similar Materials, Laser Beam Operator, Concrete Burning Machine Operator, Coring Machine Operator, Plaster Tender, Underpinning & Shoring of Buildings, Pump Man, Manhole & Catch Basin, Dirt & Stone Tamper, Hoseman on Concrete Pump.



LAB00075-002 06/01/2017

WILL COUNTY

	Rates	Fringes
LABORER		
GROUP 1.....	\$ 41.20	27.47
GROUP 2.....	\$ 41.55	27.47
GROUP 3.....	\$ 41.20	27.47
GROUP 4.....	\$ 41.55	27.47
GROUP 5.....	\$ 41.40	27.47
GROUP 6.....	\$ 41.55	27.47
GROUP 7.....	\$ 41.40	27.47

LABORER CLASSIFICATIONS

GROUP 1 - Mortar mixers, handling asphalt shingles; Scaffolds; Sewer and trench work (ground level down to 8 feet); Catch basin and manhole diggers, mesh handling on road work; Cement and mineral filler handler; Concrete puddlers; Batch dumpers (cement & asphalt); Vibrator operators; Sand and stone wheelers to mixer Handlers); Concrete wheelers; Airtamping hammermen; Concrete & paving breakers; Rock drillers/Jackhammermen; Chipping hammermen 1-Bag mixer; Asphalt laborer; Chain and power saws; Pit men; Fencing laborers; Mason tenders (mortar and brick wheeler); Kettlemen & tarmen, tank cleaners; Scaffold and staging laborers; Pot Firemen (tarmen); Heaters tender for any purpose; Water pumps (portable water pumps shall be tended by laborers if the employer determines tending is required); Rip rap; Handling of slab steel road forms in any manner, except road form setting, setting center

strips, Contraction and expansion joints (road work); Unloading and handling of lumber, brick, transite materials, cast iron water pipe, reinforced concrete rods, sewer and drain tile, railroad tiles and all other creosoted materials; paving blocks and concrete forms; Handling of insulation of any type; all work involving the unloading of materials, fixtures, or furnishing, whether crated or uncrated; all mortar and composition mixers of sewer work; track laborers; Chimney and silo laborers working at a height of 1 to 48 feet; All laborers working on swinging suspended, or any type or make of scaffolding 1 to 48 feet; All laborers working inside a sphere or any type or make of tank; Working inside a sphere or any type or make of tank from bottom to a height of 48 feet; Form strippers (any type); Mechanical or motorized buggies, for concrete or masons employers; Use of skid steer loads or any other machinery which replaces the wheelbarrow or buggy; Handling multiple concrete duct or any other type of pipe used in public utility work unless otherwise specified herein; Snapping of wall ties and removal of rods; drilling of anchor bolt holes; Concrete or asphalt clipper type saws and self-propelled saws; Shoulder and grade laborers; All hydraulic electric and air or any other type of tools; Grouting and caulking; Cleaning lumber, Nail pulling, Deck hand; Dredgehand; Shore laborer; Bankmen on Floating Plant; Tool and material checkers; Signalmen and Flagmen on all construction work; Cleaning of debris; Removal of trees; Concrete curing, temporary concrete protection regardless of manner or materials used; Laborers on Apsco; Janitorial; Wrecking and demolition laborers

GROUP 2 - Sewer and drain pipe layers and multiple concrete duct or any other type of pipe used, on public utility work (ground level to 8 feet); Pumpcrete pipe handlers

GROUP 3 - Asphalt rakers; Hod carriers; Plasterer laborers; Gunnite laborers, Slab for setters on roads, highways, streets, airport runways, and radii (any type of form) stringline men for all aforementioned work; Wagon and tower drillers on land and floating plant used on dredging; Asphalt gunners and plug men (undercoating on road work); Mortar pump laborers; Plaster pump laborers

GROUP 4 - Tunnel miners, and all laborers inside tunnel; Air blow pipemen; Torchmen (burners); Mortaring men on sewer and drain pipe (the applying of mortar and composition mixes); All bottom men on sewer work-all sewer and drain pipelayers-multiple concrete duct or any other type of pipe used on public utility work-8 feet or more below ground level, and all other sewer and trench laborers 8 feet or more below ground level regardless of excavation area; All labor work inside cofferdam; Use of a 10 foot or more drill steel for hand held drills; Caisson laborers ground level down 15 feet; All air tools 8 feet or more below ground level; All laborers working on swinging-suspended or any type or make of scaffolds, 48 feet to 100 feet; All chimney and silo laborers working at a height of 48 to 100 feet; All tamping hammers over 150 lbs.; All laborers working inside of a sphere or any type or make of tank at a height of 48 feet to 100 feet; all hydraulic, electric and air tools or any other type 8 feet or more below ground level; Vibrators-any type-8 feet or more below ground level

GROUP 5 - Gunnite nozzle men; Caisson laborers and all tamping hammers from 150 lbs and over; from 15 feet below

ground level down to 50 feet; and all laborers working inside of a sphere or any type of tank for every additional 50 feet or part thereof above 100 feet in height

GROUP 6 - All underground cavern laborers; Caisson laborers 50 feet or more below ground level; Laborers working under radio active conditions (suiting up); Blasting men (Powdermen)

GROUP 7 - Dosimeter (any device) used for monitoring nuclear exposure; Asbestos abatement worker; Toxic and hazardous waste removal laborer; and chimney and silo laborers for every additional 50 feet or any part thereof above 100 feet high

LAB00149-002 06/01/2017

BOONE, KANE, KENDALL, AND McHENRY COUNTIES

	Rates	Fringes
LABORER		
GROUP 1.....	\$ 41.20	27.47
GROUP 2.....	\$ 41.43	27.47
GROUP 3.....	\$ 41.20	27.47
GROUP 4.....	\$ 41.20	27.47
GROUP 5.....	\$ 41.43	27.47
GROUP 6.....	\$ 41.55	27.47
GROUP 7.....	\$ 41.55	27.47
GROUP 8.....	\$ 41.20	27.47
GROUP 9.....	\$ 41.40	27.47

LABORER CLASSIFICATIONS

GROUP 1: Common laborer, Asphalt laborer, Asphalt plant laborer, Striping laborer, Clipper type concrete saw, Self-propelled saws

GROUP 2: Air tampers & Vibrators

GROUP 3: Mortar & Concrete mixers

GROUP 4: Stringline & form setter; Torchman (demolition), Sheeting & Cribbing, Black top rakers & lutemen, Machine screwmen

GROUP 5: Chain saw man, Jackhammer man, Drillman, Concrete breaders & air spade,

GROUP 6: Tunnel laborers, Tile layers & bottom men

GROUP 7: Caisson diggers, Dynamiters

GROUP 8: Flagman

GROUP 9: Asbestos apatement laborers, Toxic & hazardous waste removal laborers & Dosimeter (any device) monitoring nuclear exposure

LAB00152-003 06/01/2017

LAKE COUNTY

Rates Fringes

LABORER

GROUP 1.....	\$ 41.20	27.47
GROUP 2.....	\$ 41.28	27.47
GROUP 3.....	\$ 41.20	27.47
GROUP 4.....	\$ 41.43	27.47
GROUP 5.....	\$ 41.40	27.47
GROUP 6.....	\$ 41.40	27.47

LABORER CLASSIFICATIONS

GROUP 1: General laborers; Asphalt

GROUP 2: Cement gun laborers

GROUP 3: Asphalt Tampers and Smoothers

GROUP 4: Rakers and Lutemen; Machine screwman; Kettlemen; Mixer-men, Drum-Men; Jackhammermen (Asphalt); Mite Box Spreaders; Laborers on birch overman and similar spreader equipment; Laborers on apSCO; Laborers on Air Compressors; Paving Form Setters; Jackhammerman (Concrete); Power Drive Concrete Saws

GROUP 5: Cement Gun Nozzle (Gunitite)

GROUP 6: Asbestos abatement laborers; Toxic and hazardous waste removal laborers; Dosimeter (any device monitoring nuclear exposure)

PAIN0014-003 06/01/2017

LAKE and WILL COUNTIES

	Rates	Fringes
PAINTER: Brush Only.....	\$ 44.55	26.49

PAIN0030-001 07/01/2017

DE KALB, DU PAGE, KANE, KENDALL AND MCHENRY COUNTIES

	Rates	Fringes
PAINTER Brush, Drywall Taper/Finisher, Sandblaster, and Spray.....	\$ 45.28	20.10

PAIN0030-004 07/01/2017

BOONE, JO DAVIESS, LEE, OGLE, STEPHENSON AND WINNEBAGO COUNTIES

	Rates	Fringes
PAINTER Brush, Roller, Spray, Sandblasting, Paperhanger, Drywall Finishing, Taper, and Spray Structural Steel..	\$ 39.45	20.36

PLAS0011-002 06/01/2017

WILL COUNTY

	Rates	Fringes
CEMENT MASON/CONCRETE FINISHER...	\$ 42.00	34.56

PLAS0011-008 06/01/2017		

DE KALB, KANE, KENDALL, AND McHENRY COUNTIES

	Rates	Fringes
CEMENT MASON/CONCRETE FINISHER...	\$ 44.84	31.60

PLAS0011-013 06/01/2017		

LAKE COUNTY

	Rates	Fringes
CEMENT MASON/CONCRETE FINISHER...	\$ 44.98	31.47

PLAS0011-015 06/01/2017		

BOONE COUNTY

	Rates	Fringes
CEMENT MASON/CONCRETE FINISHER...	\$ 36.99	26.93
PLASTERER.....	\$ 34.78	27.28

PLAS0803-001 08/01/2010		

DUPAGE COUNTY

	Rates	Fringes
CEMENT MASON/CONCRETE FINISHER...	\$ 38.00	24.03

* TEAM0179-002 06/01/2017		

KENDALL and WILL COUNTIES

	Rates	Fringes
TRUCK DRIVER		
2 or 3 Axle Trucks.....	\$ 37.68	0.15+a
4 Axle Trucks.....	\$ 37.83	0.15+a
5 Axle Trucks.....	\$ 38.03	0.15+a
6 Axle Trucks.....	\$ 38.23	0.15+a

FOOTNOTES:

- a. \$733.20 per week.
- b. Lowboy rate based on number of axles

An additional \$.20 per axle shall be paid for all vehicles with more than six (6) axles.

CLASSIFICATIONS:

Group 1 - Frame Truck when used for transportation purposes; Air Compressor and Welding Machines, including those pulled by cars, pick-up trucks and tractors; Ambulances; Articulated Dumps; Batch Gate Lockers; Batch Hopperman; Car and Truck Washers; Carry Alls; Forl Lifts and Hoisters; Helpers; Mechanics Helpers and Greasers; Oil Distributors,

two-man operation; Pavement Breakers; Pole Trailer, up to 40 feet; Pothole Repair Trucks; Power Mower Tractors; Quick Change Barrier; Self-Propelled Chip Spreader; Shipping and Receiving Clerks and Checkers; Skipman; Slurry Trucks, two-man operation; Slurry Trucks, Conveyor Operated - 2 or 3 man operation; Teamsters; Unskilled Dumpmen; Warehousemen and Dockmen; Truck Drivers hauling warning lights, barricades, and portable toilets on the job site

Group 2 - Dispatcher; Dump Crets and Adgetators under 7 yards; Dumpsters, Track Trucks, Euclids, Hug Bottom Dump Turnapulls or Turnatrailers when pulling other than self-loading equipment or similar equipment under 16 cubic yards; Mixer Trucks under 7 yards; Ready-Mix Plant Hopper Operator; Winch Trucks, 2 Axles

Group 3 - Dump Crets and Adgetators, 7 yards and over; Dumpsters, Track Trucks, Euclids, Hug Bottom Dump Turnapulls or Turnatrailers when pulling other than self-loading equipment or similar equipment over 16 cubic yards; Explosives and/or Fission Material Trucks; Mixer Trucks 7 yards or over; Mobile Cranes while in transit; Oil Distributors, one-man operation; Pole Trailer, over 40 feet; Pole and Expandable Trailers hauling material over 50 feet long; Slurry Trucks, one-man operation; Winch Trucks, 3 axles or more; Mechanic - *Truck Welder and *Truck Painter*These classifications shall only apply in areas where and when it has been a past area practice; Asphalt Plant Operators in areas where it has been past practice

Group 4 - Dual-purpose vehicels, such as mounted crane tucks with hoist and accessories; Foreman; Master Mechanic; Self-loading equipment like P.B. and trucks with scoops on the front

* TEAM0301-001 06/01/2017

LAKE AND MCHENRY COUNTIES

	Rates	Fringes
TRUCK DRIVER		
2-3 AXLES.....	\$ 37.69	10.15+a
4 AXLES.....	\$ 37.84	10.15+a
5 AXLES.....	\$ 38.04	10.15+a
6 AXLES.....	\$ 38.24	10.15+a

FOOTNOTES:

- a. 325.20 per week.
- b. Lowboy rate based on number of axles

An additional \$.20 per axle shall be paid for all vehicles with more than six (6) axles.

Paid Holidays: New Year's Day, Memorial Day, Independence Day, Labor Day, Thanksgiving Day, and Christmas Day.

900 straight time hours or more in 1 calendar year for the same employer shall receive 1 week paid vacation; 3 years - 2 weeks paid vacation; 10 years - 3 weeks paid vacation; 20 years - 4 weeks paid vacation.

CLASSIFICATIONS:

Group 1 - Frame Truck when used for transportation purposes; Air Compressor and Welding Machines, including those pulled by cars, pick-up trucks and tractors; Ambulances; Articulated Dumps; Batch Gate Lockers; Batch Hopperman; Car and Truck Washers; Carry Alls; Forl Lifts and Hoisters; Helpers; Mechanics Helpers and Greasers; Oil Distributors, two-man operation; Pavement Breakers; Pole Trailer, up to 40 feet; Pothole Repair Trucks; Power Mower Tractors; Quick Change Barrier; Self-Propelled Chip Spreader; Shipping and Receiving Clerks and Checkers; Skipman; Slurry Trucks, two-man operation; Slurry Trucks, Conveyor Operated - 2 or 3 man operation; Teamsters; Unskilled Dumpmen; Warehousemen and Dockmen; Truck Drivers hauling warning lights, barricades, and portable toilets on the job site

Group 2 - Dispatcher; Dump Crets and Adgetators under 7 yards; Dumpsters, Track Trucks, Euclids, Hug Bottom Dump Turnapulls or Turnatrailers when pulling other than self-loading equipment or similar equipment under 16 cubic yards; Mixer Trucks under 7 yards; Ready-Mix Plant Hopper Operator; Winch Trucks, 2 Axles

Group 3 - Dump Crets and Adgetators, 7 yards and over; Dumpsters, Track Trucks, Euclids, Hug Bottom Dump Turnapulls or Turnatrailers when pulling other than self-loading equipment or similar equipment over 16 cubic yards; Explosives and/or Fission Material Trucks; Mixer Trucks 7 yards or over; Mobile Cranes while in transit; Oil Distributors, one-man operation; Pole Trailer, over 40 feet; Pole and Expandable Trailers hauling material over 50 feet long; Slurry Trucks, one-man operation; Winch Trucks, 3 axles or more; Mechanic - *Truck Welder and *Truck Painter*These classifications shall only apply in areas where and when it has been a past area practice; Asphalt Plant Operators in areas where it has been past practice

Group 4 - Dual-purpose vehicels, such as mounted crane tucks with hoist and accessories; Foreman; Master Mechanic; Self-loading equipment like P.B. and trucks with scoops on the front

* TEAM0325-004 06/01/2017

BOONE and WINNEBAGO COUNTIES

	Rates	Fringes
TRUCK DRIVER		
2 - 3 Axles.....	\$ 36.62	20.40
4 Axles.....	\$ 36.77	20.40
5 Axles.....	\$ 36.97	20.40
6 Axles.....	\$ 37.08	20.40

FOOTNOTE: An additional \$.20 per axle shall be paid for all vehicles with more than six (6) axles.

CLASSIFICATIONS:

Group 1 - Frame Truck when used for transportation purposes; Air Compressor and Welding Machines, including those pulled by cars, pick-up trucks and tractors; Ambulances; Batch Gate Lockers; Batch Hopperman; Car and Truck Washers; Forl

Lifts and Hoisters; Helpers; Mechanics Helpers and Greasers; Oil Distributors, two-man operation; Pavement Breakers Pole Trailer, up to 40 feet; Power Mower Tractors; Skipman; Slurry Trucks, two-man operation; Teamsters; Truck Drivers hauling warning lights, barricades, and portable toilets on the job site

Group 2 - Dump Crets and Adgetators under 7 yards; Dumpsters, Track Trucks, Euclids, Hug Bottom Dump Turnapulls or Turnatrailers when pulling other than self-loading equipment or similar equipment under 16 cubic yards; Mixer Trucks under 7 yards; Ready-Mix Plant Hopper Operator; Winch Trucks, 2 Axles

Group 3 - Dump Crets and Adgetators, 7 yards and over; Dumpsters, Track Trucks, Euclids, Hug Bottom Dump Turnapulls or Turnatrailers when pulling other than self-loading equipment or similar equipment over 16 cubic yards; Explosives and/or Fission Material Trucks; Mixer Trucks 7 yards or over; Mobile Cranes while in transit; Oil Distributors, one-man operation Pole Trailer, over 40 feet; Pole and Expandable Trailers hauling material over 50 feet long, additional \$0.50 per hour; Slurry Trucks, one-man operation; Winch Trucks, 3 axles or more

*Mechanic*Truck Welder and Truck Painter; *Winter Rate: Between Dec. 15 and Feb. 28 the mechanic and welder rate shall be \$2.00 less than the scheduled scale. Truck Painter and Truck Welder classifications shall only apply in areas where and when it has been a past area practice; Dual-purpose vehicels, such as mounted crane tucks with hoist and accessories

Group 4 - Foreman; Master Mechanic; Self-loading equipment like P.B. and trucks with scoops on the front

* TEAM0330-002 06/01/2017

DEKALB COUNTY

	Rates	Fringes
TRUCK DRIVER		
2-3 AXLES.....	\$ 36.64	0.15+a
4 AXLES.....	\$ 36.79	0.15+a
5 AXLES.....	\$ 36.99	0.15+a
6 AXLES.....	\$ 37.19	0.15+a

FOOTNOTE: a. \$780.90 per week

An additional \$.20 per axle shall be paid for all vehicles with more than six (6) axles.

Paid Holidays: New Year's Day, Memorial Day, Independence Day, Labor Day, Thanksgiving Day, and Christmas Day.

900 straight time hours or more in 1 calendar year for the same employer shall receive 1 week paid vacation; 3 years - 2 weeks paid vacation; 10 years - 3 weeks paid vacation; 20 years - 4 weeks paid vacation.

CLASSIFICATIONS:

Group 1 - Frame Truck when used for transportation purposes; Air Compressor and Welding Machines, including those pulled by cars, pick-up trucks and tractors; Ambulances; Articulated Dumps; Batch Gate Lockers; Batch Hopperman; Car and Truck Washers; Carry Alls; Forl Lifts and Hoisters; Helpers; Mechanics Helpers and Greasers; Oil Distributors, two-man operation; Pavement Breakers; Pole Trailer, up to 40 feet; Pothole Repair Trucks; Power Mower Tractors; Quick Change Barrier; Self-Propelled Chip Spreader; Shipping and Receiving Clerks and Checkers; Skipman; Slurry Trucks, two-man operation; Slurry Trucks, Conveyor Operated - 2 or 3 man operation; Teamsters; Unskilled Dumpmen; Warehousemen and Dockmen; Truck Drivers hauling warning lights, barricades, and portable toilets on the job site

Group 2 - Dispatcher; Dump Crets and Adgetators under 7 yards; Dumpsters, Track Trucks, Euclids, Hug Bottom Dump Turnapulls or Turnatrailers when pulling other than self-loading equipment or similar equipment under 16 cubic yards; Mixer Trucks under 7 yards; Ready-Mix Plant Hopper Operator; Winch Trucks, 2 Axles

Group 3 - Dump Crets and Adgetators, 7 yards and over; Dumpsters, Track Trucks, Euclids, Hug Bottom Dump Turnapulls or Turnatrailers when pulling other than self-loading equipment or similar equipment over 16 cubic yards; Explosives and/or Fission Material Trucks; Mixer Trucks 7 yards or over; Mobile Cranes while in transit; Oil Distributors, one-man operation; Pole Trailer, over 40 feet; Pole and Expandable Trailers hauling material over 50 feet long; Slurry Trucks, one-man operation; Winch Trucks, 3 axles or more; Mechanic - *Truck Welder and *Truck Painter*These classifications shall only apply in areas where and when it has been a past area practice; Asphalt Plant Operators in areas where it has been past practice

Group 4 - Dual-purpose vehicels, such as mounted crane tucks with hoist and accessories; Foreman; Master Mechanic; Self-loading equipment like P.B. and trucks with scoops on the front

* TEAM0673-003 06/01/2017

DU PAGE and KANE COUNTIES

	Rates	Fringes
TRUCK DRIVER		
2-3 AXLES.....	\$ 36.93	0.15+a
4 AXLES.....	\$ 37.08	0.15+a
5 AXLES.....	\$ 37.28	0.15+a
6 AXLES.....	\$ 37.48	0.15+a

FOOTNOTE: a. \$767.70 per week.

An additional \$.20 per axle shall be paid for all vehicles with more than six (6) axles.

Paid Holidays: New Year's Day, Memorial Day, Independence Day, Labor Day, Thanksgiving Day, and Christmas Day.

900 straight time hours or more in 1 calendar year for the same employer shall receive 1 week paid vacation; 3 years -

2 weeks paid vacation; 10 years - 3 weeks paid vacation; 20 years - 4 weeks paid vacation.

CLASSIFICATIONS:

Group 1 - Frame Truck when used for transportation purposes; Air Compressor and Welding Machines, including those pulled by cars, pick-up trucks and tractors; Ambulances; Articulated Dumps; Batch Gate Lockers; Batch Hopperman; Car and Truck Washers; Carry Alls; Forl Lifts and Hoisters; Helpers; Mechanics Helpers and Greasers; Oil Distributors, two-man operation; Pavement Breakers; Pole Trailer, up to 40 feet; Pothole Repair Trucks; Power Mower Tractors; Quick Change Barrier; Self-Propelled Chip Spreader; Shipping and Receiving Clerks and Checkers; Skipman; Slurry Trucks, two-man operation; Slurry Trucks, Conveyor Operated - 2 or 3 man operation; Teamsters; Unskilled Dumpmen; Warehousemen and Dockmen; Truck Drivers hauling warning lights, barricades, and portable toilets on the job site

Group 2 - Dispatcher; Dump Crets and Adgetators under 7 yards; Dumpsters, Track Trucks, Euclids, Hug Bottom Dump Turnapulls or Turnatrailers when pulling other than self-loading equipment or similar equipment under 16 cubic yards; Mixer Trucks under 7 yards; Ready-Mix Plant Hopper Operator; Winch Trucks, 2 Axles

Group 3 - Dump Crets and Adgetators, 7 yards and over; Dumpsters, Track Trucks, Euclids, Hug Bottom Dump Turnapulls or Turnatrailers when pulling other than self-loading equipment or similar equipment over 16 cubic yards; Explosives and/or Fission Material Trucks; Mixer Trucks 7 yards or over; Mobile Cranes while in transit; Oil Distributors, one-man operation; Pole Trailer, over 40 feet; Pole and Expandable Trailers hauling material over 50 feet long; Slurry Trucks, one-man operation; Winch Trucks, 3 axles or more; Mechanic - *Truck Welder and *Truck Painter*These classifications shall only apply in areas where and when it has been a past area practice; Asphalt Plant Operators in areas where it has been past practice

Group 4 - Dual-purpose vehicels, such as mounted crane tucks with hoist and accessories; Foreman; Master Mechanic; Self-loading equipment like P.B. and trucks with scoops on the front

WELDERS - Receive rate prescribed for craft performing operation to which welding is incidental.
=====

Note: Executive Order (EO) 13706, Establishing Paid Sick Leave for Federal Contractors applies to all contracts subject to the Davis-Bacon Act for which the contract is awarded (and any solicitation was issued) on or after January 1, 2017. If this contract is covered by the EO, the contractor must provide employees with 1 hour of paid sick leave for every 30 hours they work, up to 56 hours of paid sick leave each year. Employees must be permitted to use paid sick leave for their own illness, injury or other health-related needs, including preventive care; to assist a family member (or person who is like family to the employee) who is ill, injured, or has other

health-related needs, including preventive care; or for reasons resulting from, or to assist a family member (or person who is like family to the employee) who is a victim of, domestic violence, sexual assault, or stalking. Additional information on contractor requirements and worker protections under the EO is available at www.dol.gov/whd/govcontracts.

Unlisted classifications needed for work not included within the scope of the classifications listed may be added after award only as provided in the labor standards contract clauses (29CFR 5.5 (a) (1) (ii)).

The body of each wage determination lists the classification and wage rates that have been found to be prevailing for the cited type(s) of construction in the area covered by the wage determination. The classifications are listed in alphabetical order of "identifiers" that indicate whether the particular rate is a union rate (current union negotiated rate for local), a survey rate (weighted average rate) or a union average rate (weighted union average rate).

Union Rate Identifiers

A four letter classification abbreviation identifier enclosed in dotted lines beginning with characters other than "SU" or "UAVG" denotes that the union classification and rate were prevailing for that classification in the survey. Example: PLUM0198-005 07/01/2014. PLUM is an abbreviation identifier of the union which prevailed in the survey for this classification, which in this example would be Plumbers. 0198 indicates the local union number or district council number where applicable, i.e., Plumbers Local 0198. The next number, 005 in the example, is an internal number used in processing the wage determination. 07/01/2014 is the effective date of the most current negotiated rate, which in this example is July 1, 2014.

Union prevailing wage rates are updated to reflect all rate changes in the collective bargaining agreement (CBA) governing this classification and rate.

Survey Rate Identifiers

Classifications listed under the "SU" identifier indicate that no one rate prevailed for this classification in the survey and the published rate is derived by computing a weighted average rate based on all the rates reported in the survey for that classification. As this weighted average rate includes all rates reported in the survey, it may include both union and non-union rates. Example: SULA2012-007 5/13/2014. SU indicates the rates are survey rates based on a weighted average calculation of rates and are not majority rates. LA indicates the State of Louisiana. 2012 is the year of survey on which these classifications and rates are based. The next number, 007 in the example, is an internal number used in producing the wage determination. 5/13/2014 indicates the survey completion date for the classifications and rates under that identifier.

Survey wage rates are not updated and remain in effect until a new survey is conducted.

Union Average Rate Identifiers

Classification(s) listed under the UAVG identifier indicate that no single majority rate prevailed for those classifications; however, 100% of the data reported for the classifications was union data. EXAMPLE: UAVG-OH-0010 08/29/2014. UAVG indicates that the rate is a weighted union average rate. OH indicates the state. The next number, 0010 in the example, is an internal number used in producing the wage determination. 08/29/2014 indicates the survey completion date for the classifications and rates under that identifier.

A UAVG rate will be updated once a year, usually in January of each year, to reflect a weighted average of the current negotiated/CBA rate of the union locals from which the rate is based.

WAGE DETERMINATION APPEALS PROCESS

1.) Has there been an initial decision in the matter? This can be:

- * an existing published wage determination
- * a survey underlying a wage determination
- * a Wage and Hour Division letter setting forth a position on a wage determination matter
- * a conformance (additional classification and rate) ruling

On survey related matters, initial contact, including requests for summaries of surveys, should be with the Wage and Hour Regional Office for the area in which the survey was conducted because those Regional Offices have responsibility for the Davis-Bacon survey program. If the response from this initial contact is not satisfactory, then the process described in 2.) and 3.) should be followed.

With regard to any other matter not yet ripe for the formal process described here, initial contact should be with the Branch of Construction Wage Determinations. Write to:

Branch of Construction Wage Determinations
Wage and Hour Division
U.S. Department of Labor
200 Constitution Avenue, N.W.
Washington, DC 20210

2.) If the answer to the question in 1.) is yes, then an interested party (those affected by the action) can request review and reconsideration from the Wage and Hour Administrator (See 29 CFR Part 1.8 and 29 CFR Part 7). Write to:

Wage and Hour Administrator
U.S. Department of Labor
200 Constitution Avenue, N.W.
Washington, DC 20210

The request should be accompanied by a full statement of the interested party's position and by any information (wage payment data, project description, area practice material, etc.) that the requestor considers relevant to the issue.

3.) If the decision of the Administrator is not favorable, an interested party may appeal directly to the Administrative Review Board (formerly the Wage Appeals Board). Write to:

Administrative Review Board
U.S. Department of Labor
200 Constitution Avenue, N.W.
Washington, DC 20210

4.) All decisions by the Administrative Review Board are final.

=====

END OF GENERAL DECISION

NOT FOR BID

General Decision Number: IL180020 05/11/2018 IL20

Superseded General Decision Number: IL20170020

State: Illinois

Construction Types: Building Landscape, Heavy Landscape, Highway Landscape and Residential Landscape

Counties: Boone, Cook, De Kalb, Du Page, Grundy, Henry, Kane, Kankakee, Kendall, Lake, McHenry, McLean, Ogle, Peoria, Rock Island, Tazewell, Will, Winnebago and Woodford Counties in Illinois.

LANDSCAPING WORK ON BUILDING, RESIDENTIAL, HEAVY AND HIGHWAY CONSTRUCTION PROJECTS.

Note: Under Executive Order (EO) 13658, an hourly minimum wage of \$10.35 for calendar year 2018 applies to all contracts subject to the Davis-Bacon Act for which the contract is awarded (and any solicitation was issued) on or after January 1, 2015. If this contract is covered by the EO, the contractor must pay all workers in any classification listed on this wage determination at least \$10.35 per hour (or the applicable wage rate listed on this wage determination, if it is higher) for all hours spent performing on the contract in calendar year 2018. The EO minimum wage rate will be adjusted annually. Please note that this EO applies to the above-mentioned types of contracts entered into by the federal government that are subject to the Davis-Bacon Act itself, but it does not apply to contracts subject only to the Davis-Bacon Related Acts, including those set forth at 29 CFR 5.1(a)(2)-(60). Additional information on contractor requirements and worker protections under the EO is available at www.dol.gov/whd/govcontracts.

Modification Number	Publication Date
0	01/05/2018
1	04/27/2018
2	05/04/2018
3	05/11/2018

ENGI0150-013 06/01/2017

BUILDING AND HIGHWAY CONSTRUCTION (LANDSCAPE WORK): The landscape work for the Landscape Equipment Operator excludes the preparation of sub-grade prior to application of finish landscape materials and the utilization of any equipment over one cubic yard.

BOONE, COOK, DUPAGE, GRUNDY, KANE, KENDALL, LAKE, MCHENRY, AND WILL COUNTIES

Rates Fringes

Operators:.....\$ 31.10 \$6.00+A+B
Includes Angle Dozer, Small; Bobcat and other similar type machines, 1 cu yd or less; Chipping Machine; Combination Backhoe and Front End Loader 1 cu yd or less; Fork Lift Truck; Hi-Reach and High-Ranger;Hydraulic Boom with Clam;Log Skidder; Strow Blower and Seeder; Stump Machine;Tractors, Crawlers, Rubber Tire Tractors, Highlift Shovels or Front End Loaders 1 cu yd or less; Tree Spades, all; Utility Tractor and attachments, and Rubber Tire Front End loader or similar machine of 1 to 1.5 cu yd solely used for placement of large decorative boulders, trees with balled soil, and other decorative landscape material too large to be accommodated in a 1 cu yd bucket. All other equipment utilized for performing landscape work, tree trimming or removal of stees, and to install plants; transport trees; excavate plant pits; place soil and other landscape materials; and apply finish landscape material on subgrade prepared by others

FOOTNOTE:

A. Health and Welfare contribution is \$1,240.00 per month.

B. Paid Holidays: New Year's Day; Memorial Day; Fourth of July; Labor Day; Thanksgiving Day; and Christmas Day provided that all such employees shall have in fact worked their regularly scheduled work day immediately preceding and the regularly scheduled work day immediately succeeding the occurrence of such holiday.

ENGI0150-023 06/01/2017

HIGHWAY CONSTRUCTION (LANDSCAPE WORK): The landscape work for the Landscape Equipment Operator excludes the preparation of sub-grade prior to application of finish landscape materials and the utilization of any equipment over one cubic yard.

HENRY, MCLEAN, OGLE, PEORIA, ROCK ISLAND, TAZEWELL, WINNEBAGO, and WOODFORD COUNTIES

	Rates	Fringes
Operators:.....	\$ 31.10	\$6.00+A+B
Includes the following: Angle Dozer, Small; Bobcat and other similar type machines, 1 cu yd or less; Chipping Machine; Combination Backhoe and Front End Loader 1 cu yd or less; Fork Lift Truck; Hi-Reach and High-Ranger;Hydraulic Boom with Clam;Log Skidder; Sstraw Blower and Seeder; Stump Machine;Tractors, Crawlers, Rubber Tire Tractors, Highlift Shovels or Front End Loaders 1 cu yd or less; Tree Spades, all; Utility Tractor and attachments, and Rubber Tire Front End loader or similar machine of 1 to 1.5 cu yd solely used for placement of large decorative boulders, trees with balled soil, and other decorative landscape material too large to be accommodated in a 1 cu yd bucket. All other equipment utilized for performing landscape work, tree trimming or removal of stees, and to install plants; transport trees; excavate plant pits; place soil and other landscape materials; and apply finish landscape material on subgrade prepared by others		

FOOTNOTE:

- A. Health and Welfare contribution is \$1,240.00 per month.
- B. Paid Holidays: New Year's Day; Memorial Day; Fourth of July; Labor Day; Thanksgiving Day; and Christmas Day provided that all such employees shall have in fact worked their regularly scheduled work day immediately preceding and the regularly scheduled work day immediately succeeding the occurrence of such holiday.

* LAB0032-004 05/01/2018

HIGHWAY CONSTRUCTION

WINNEBAGO COUNTY

	Rates	Fringes
Landscape Laborer.....	\$ 35.40	31.73

LAB00362-003 05/01/2018

HIGHWAY CONSTRUCTION

MCLEAN COUNTY

	Rates	Fringes
Landscape Laborer.....	\$ 31.08	24.43

LAB00751-004 05/01/2012

HIGHWAY CONSTRUCTION

KANKAKEE COUNTY

	Rates	Fringes
Landscape Laborer.....	\$ 33.16	20.66

LAB00852-004 05/01/2006

HIGHWAY CONSTRUCTION

ROCK ISLAND AND HENRY COUNTIES

	Rates	Fringes
Landscape Laborer.....	\$ 21.94	12.79

* LAB00996-004 05/01/2018

HIGHWAY CONSTRUCTION

PEORIA, TAZEWELL, AND WOODFORD COUNTIES

	Rates	Fringes
Landscape Laborer.....	\$ 32.73	23.74

TEAM0026-005 05/01/2017

MCLEAN (South of a straight line from where Route 24 intersects the Woodford County line in a Southeast direction to the South Southwest corner of Livingston County) COUNTY

	Rates	Fringes
TRUCK DRIVER		
Group 1.....	\$ 36.15	18.30
Group 2.....	\$ 36.67	18.30
Group 3.....	\$ 36.91	18.30
Group 4.....	\$ 37.25	18.30
Group 5.....	\$ 38.23	18.30

CLASSIFICATIONS:

GROUP 1: Drivers on 2 axles hauling less than 9 tons; air compressor & welding machines and brooms, including those pulled by separate units; Truck Driver Helper, warehouse employees; Mechanic Helpers; greasers and tiremen; pick-up trucks when hauling material, tools, or workers to and from and on the job site; and forklifts up to 6,000 lb capacity.

GROUP 2: 2 or 3 axles hauling more than 9 tons but hauling less than 16 tons; A-frame winch trucks; hydrolift trucks; Vector Trucks or similar equipment when used for transportation purposes; Forklift over 6,000 lb.capacity; winch trucks; and four axle combination units.

GROUP 3: 2, 3 or 4 Axles hauling 16 tons or more; 5-Axles or more combination units; drivers on water pulls; articulated dump trucks; mechanics and working forepersons.

GROUP 4: Low Boy and Oil Distributors.

GROUP 5: Drivers who require special protective clothing while employed on hazardous waste work.

* TEAM0179-004 06/01/2017

GRUNDY, KENDALL, MCLEAN (North of a straight line starting at the intersection of McLean-Woodford Counties line & Route 24 in a Southeastern direction to the South Southwest corner of Livingston County), WILL, and WOODFORD (Northeast corner east of Route 51/251 & North of Route 24) COUNTIES

	Rates	Fringes
TRUCK DRIVER		
2-3 AXLES.....	\$ 37.68	0.15+a
4 AXLES.....	\$ 37.83	0.15+a
5 AXLES.....	\$ 38.03	0.15+a
6 AXLES.....	\$ 38.23	0.15+a

FOOTNOTES:

- a. \$733.20 per week.
- b. Lowboy rate based on number of axles

An additional \$.20 per axle shall be paid for all vehicles with more than six (6) axles.

CLASSIFICATIONS:

Group 1 - Frame Truck when used for transportation purposes; Air Compressor and Welding Machines, including those pulled by cars, pick-up trucks and tractors; Ambulances; Articulated Dumps; Batch Gate Lockers; Batch Hopperman; Car and Truck Washers; Carry Alls; Forl Lifts and Hoisters; Helpers; Mechanics Helpers and Greasers; Oil Distributors, two-man operation; Pavement Breakers; Pole Trailer, up to 40 feet; Pothole Repair Trucks; Power Mower Tractors; Quick Change Barrier; Self-Propelled Chip Spreader; Shipping and Receiving Clerks and Checkers; Skipman; Slurry Trucks, two-man operation; Slurry Trucks, Conveyor Operated - 2 or 3 man operation; Teamsters; Unskilled Dumpmen; Warehousemen and Dockmen; Truck Drivers hauling warning lights, barricades, and portable toilets on the job site

Group 2 - Dispatcher; Dump Crets and Adgetators under 7 yards; Dumpsters, Track Trucks, Euclids, Hug Bottom Dump Turnapulls or Turnatrailers when pulling other than

self-loading equipment or similar equipment under 16 cubic yards; Mixer Trucks under 7 yards; Ready-Mix Plant Hopper Operator; Winch Trucks, 2 Axles

Group 3 - Dump Crets and Adgetators, 7 yards and over; Dumpsters, Track Trucks, Euclids, Hug Bottom Dump Turnapulls or Turnatrailers when pulling other than self-loading equipment or similar equipment over 16 cubic yards; Explosives and/or Fission Material Trucks; Mixer Trucks 7 yards or over; Mobile Cranes while in transit; Oil Distributors, one-man operation; Pole Trailer, over 40 feet; Pole and Expandable Trailers hauling material over 50 feet long; Slurry Trucks, one-man operation; Winch Trucks, 3 axles or more; Mechanic - *Truck Welder and *Truck Painter*These classifications shall only apply in areas where and when it has been a past area practice; Asphalt Plant Operators in areas where it has been past practice

Group 4 - Dual-purpose vehicels, such as mounted crane tucks with hoist and accessories; Foreman; Master Mechanic; Self-loading equipment like P.B. and trucks with scoops on the front

* TEAM0179-008 06/01/2016

KANKAKEE COUNTY

	Rates	Fringes
TRUCK DRIVER		
2 or 3 axles.....	\$ 37.68	0.15+a
4 axles.....	\$ 37.83	0.15+a
5 axles.....	\$ 38.03	0.15+a
6 axles.....	\$ 38.23	0.15+a

FOOTNOTES:

- a. \$733.20 per week.
- b. Lowboy rate based on number of axles

An additional \$.20 per axle shall be paid for all vehicles with more than six (6) axles.

CLASSIFICATIONS:

Group 1 - Frame Truck when used for transportation purposes; Air Compressor and Welding Machines, including those pulled by cars, pick-up trucks and tractors; Ambulances; Articulated Dumps; Batch Gate Lockers; Batch Hopperman; Car and Truck Washers; Carry Alls; Forl Lifts and Hoisters; Helpers; Mechanics Helpers and Greasers; Oil Distributors, two-man operation; Pavement Breakers; Pole Trailer, up to 40 feet; Pothole Repair Trucks; Power Mower Tractors; Quick Change Barrier; Self-Propelled Chip Spreader; Shipping and Receiving Clerks and Checkers; Skipman; Slurry Trucks, two-man operation; Slurry Trucks, Conveyor Operated - 2 or 3 man operation; Teamsters; Unskilled Dumpmen; Warehousemen and Dockmen; Truck Drivers hauling warning lights, barricades, and portable toilets on the job site

Group 2 - Dispatcher; Dump Crets and Adgetators under 7 yards; Dumpsters, Track Trucks, Euclids, Hug Bottom Dump Turnapulls or Turnatrailers when pulling other than self-loading equipment or similar equipment under 16 cubic yards; Mixer Trucks under 7 yards; Ready-Mix Plant Hopper Operator; Winch Trucks, 2 Axles

Group 3 - Dump Crets and Adgetators, 7 yards and over; Dumpsters, Track Trucks, Euclids, Hug Bottom Dump Turnapulls or Turnatrailers when pulling other than self-loading equipment or similar equipment over 16 cubic yards; Explosives and/or Fission Material Trucks; Mixer Trucks 7 yards or over; Mobile Cranes while in transit; Oil Distributors, one-man operation; Pole Trailer, over 40 feet; Pole and Expandable Trailers hauling material over 50 feet long; Slurry Trucks, one-man operation; Winch Trucks, 3 axles or more; Mechanic - *Truck Welder and *Truck Painter*These classifications shall only apply in areas where and when it has been a past area practice; Asphalt Plant Operators in areas where it has been past practice

Group 4 - Dual-purpose vehicels, such as mounted crane tucks with hoist and accessories; Foreman; Master Mechanic; Self-loading equipment like P.B. and trucks with scoops on the front

* TEAM0301-001 06/01/2017

LAKE AND MCHENRY COUNTIES

	Rates	Fringes
TRUCK DRIVER		
2-3 AXLES.....	\$ 37.69	10.15+a
4 AXLES.....	\$ 37.84	10.15+a
5 AXLES.....	\$ 38.04	10.15+a
6 AXLES.....	\$ 38.24	10.15+a

FOOTNOTES:

- a. 325.20 per week.
- b. Lowboy rate based on number of axles

An additional \$.20 per axle shall be paid for all vehicles with more than six (6) axles.

Paid Holidays: New Year's Day, Memorial Day, Independence Day, Labor Day, Thanksgiving Day, and Christmas Day.

900 straight time hours or more in 1 calendar year for the same employer shall receive 1 week paid vacation; 3 years - 2 weeks paid vacation; 10 years - 3 weeks paid vacation; 20 years - 4 weeks paid vacation.

CLASSIFICATIONS:

Group 1 - Frame Truck when used for transportation purposes; Air Compressor and Welding Machines, including those pulled by cars, pick-up trucks and tractors; Ambulances; Articulated Dumps; Batch Gate Lockers; Batch Hopperman; Car and Truck Washers; Carry Alls; Forl Lifts and Hoisters; Helpers; Mechanics Helpers and Greasers; Oil Distributors, two-man operation; Pavement Breakers; Pole Trailer, up to 40 feet; Pothole Repair Trucks; Power Mower Tractors; Quick Change Barrier; Self-Propelled Chip Spreader; Shipping and Receiving Clerks and Checkers; Skipman; Slurry Trucks, two-man operation; Slurry Trucks, Conveyor Operated - 2 or 3 man operation; Teamsters; Unskilled Dumpmen; Warehousemen and Dockmen; Truck Drivers hauling warning lights, barricades, and portable toilets on the job site

Group 2 - Dispatcher; Dump Crets and Adgetators under 7 yards; Dumpsters, Track Trucks, Euclids, Hug Bottom Dump Turnapulls or Turnatrailers when pulling other than self-loading equipment or similar equipment under 16 cubic yards; Mixer Trucks under 7 yards; Ready-Mix Plant Hopper Operator; Winch Trucks, 2 Axles

Group 3 - Dump Crets and Adgetators, 7 yards and over; Dumpsters, Track Trucks, Euclids, Hug Bottom Dump Turnapulls or Turnatrailers when pulling other than self-loading equipment or similar equipment over 16 cubic yards; Explosives and/or Fission Material Trucks; Mixer Trucks 7 yards or over; Mobile Cranes while in transit; Oil Distributors, one-man operation; Pole Trailer, over 40 feet; Pole and Expandable Trailers hauling material over 50 feet long; Slurry Trucks, one-man operation; Winch Trucks, 3 axles or more; Mechanic - *Truck Welder and *Truck Painter*These classifications shall only apply in areas where and when it has been a past area practice; Asphalt Plant Operators in areas where it has been past practice

Group 4 - Dual-purpose vehicels, such as mounted crane tucks with hoist and accessories; Foreman; Master Mechanic; Self-loading equipment like P.B. and trucks with scoops on the front

* TEAM0325-004 06/01/2017

BOONE and WINNEBAGO COUNTIES

	Rates	Fringes
TRUCK DRIVER		
2 - 3 Axles.....	\$ 36.62	20.40
4 Axles.....	\$ 36.77	20.40
5 Axles.....	\$ 36.97	20.40
6 Axles.....	\$ 37.08	20.40

FOOTNOTE: An additional \$.20 per axle shall be paid for all vehicles with more than six (6) axles.

CLASSIFICATIONS:

Group 1 - Frame Truck when used for transportation purposes; Air Compressor and Welding Machines, including those pulled

by cars, pick-up trucks and tractors; Ambulances; Batch Gate Lockers; Batch Hopperman; Car and Truck Washers; Forl Lifts and Hoisters; Helpers; Mechanics Helpers and Greasers; Oil Distributors, two-man operation; Pavement Breakers Pole Trailer, up to 40 feet; Power Mower Tractors; Skipman; Slurry Trucks, two-man operation; Teamsters; Truck Drivers hauling warning lights, barricades, and portable toilets on the job site

Group 2 - Dump Crets and Adgetators under 7 yards; Dumpsters, Track Trucks, Euclids, Hug Bottom Dump Turnapulls or Turntrailers when pulling other than self-loading equipment or similar equipment under 16 cubic yards; Mixer Trucks under 7 yards; Ready-Mix Plant Hopper Operator; Winch Trucks, 2 Axles

Group 3 - Dump Crets and Adgetators, 7 yards and over; Dumpsters, Track Trucks, Euclids, Hug Bottom Dump Turnapulls or Turntrailers when pulling other than self-loading equipment or similar equipment over 16 cubic yards; Explosives and/or Fission Material Trucks; Mixer Trucks 7 yards or over; Mobile Cranes while in transit; Oil Distributors, one-man operation Pole Trailer, over 40 feet; Pole and Expandable Trailers hauling material over 50 feet long, additional \$0.50 per hour; Slurry Trucks, one-man operation; Winch Trucks, 3 axles or more *Mechanic*Truck Welder and Truck Painter; *Winter Rate: Between Dec. 15 and Feb. 28 the mechanic and welder rate shall be \$2.00 less than the scheduled scale. Truck Painter and Truck Welder classifications shall only apply in areas where and when it has been a past area practice; Dual-purpose vehicels, such as mounted crane tucks with hoist and accessories

Group 4 - Foreman; Master Mechanic; Self-loading equipment like P.B. and trucks with scoops on the front

* TEAM0330-004 06/01/2017

DEKALB and OGLE (North of Route 72/East of Route 251, Adeline, Byron, Creston, Dement, Forreston North of Route 72, Leaf River North of Route 72, Lynnville, Monroe, Rochelle, & Scott) COUNTIES

	Rates	Fringes
TRUCK DRIVER		
2-3 AXLES.....	\$ 36.64	0.15+a
4 AXLES.....	\$ 36.79	0.15+a
5 AXLES.....	\$ 36.99	0.15+a
6 AXLES.....	\$ 37.19	0.15+a

FOOTNOTE: a. \$780.90 per week

An additional \$.20 per axle shall be paid for all vehicles with more than six (6) axles.

Paid Holidays: New Year's Day, Memorial Day, Independence Day, Labor Day, Thanksgiving Day, and Christmas Day.

900 straight time hours or more in 1 calendar year for the same employer shall receive 1 week paid vacation; 3 years - 2 weeks paid vacation; 10 years - 3 weeks paid vacation; 20 years - 4 weeks paid vacation.

CLASSIFICATIONS:

Group 1 - Frame Truck when used for transportation purposes; Air Compressor and Welding Machines, including those pulled by cars, pick-up trucks and tractors; Ambulances; Articulated Dumps; Batch Gate Lockers; Batch Hopperman; Car and Truck Washers; Carry Alls; Forl Lifts and Hoisters; Helpers; Mechanics Helpers and Greasers; Oil Distributors, two-man operation; Pavement Breakers; Pole Trailer, up to 40 feet; Pothole Repair Trucks; Power Mower Tractors; Quick Change Barrier; Self-Propelled Chip Spreader; Shipping and Receiving Clerks and Checkers; Skipman; Slurry Trucks, two-man operation; Slurry Trucks, Conveyor Operated - 2 or 3 man operation; Teamsters; Unskilled Dumpmen; Warehousemen and Dockmen; Truck Drivers hauling warning lights, barricades, and portable toilets on the job site

Group 2 - Dispatcher; Dump Crets and Adgetators under 7 yards; Dumpsters, Track Trucks, Euclids, Hug Bottom Dump Turnapulls or Turntrailers when pulling other than self-loading equipment or similar equipment under 16 cubic

yards; Mixer Trucks under 7 yards; Ready-Mix Plant Hopper Operator; Winch Trucks, 2 Axles

Group 3 - Dump Crets and Adgetators, 7 yards and over; Dumpsters, Track Trucks, Euclids, Hug Bottom Dump Turnpulls or Turntrailers when pulling other than self-loading equipment or similar equipment over 16 cubic yards; Explosives and/or Fission Material Trucks; Mixer Trucks 7 yards or over; Mobile Cranes while in transit; Oil Distributors, one-man operation; Pole Trailer, over 40 feet; Pole and Expandable Trailers hauling material over 50 feet long; Slurry Trucks, one-man operation; Winch Trucks, 3 axles or more; Mechanic - *Truck Welder and *Truck Painter*These classifications shall only apply in areas where and when it has been a past area practice; Asphalt Plant Operators in areas where it has been past practice

Group 4 - Dual-purpose vehicels, such as mounted crane tucks with hoist and accessories; Foreman; Master Mechanic; Self-loading equipment like P.B. and trucks with scoops on the front

TEAM0371-004 05/01/2017

HENRY and ROCK ISLAND COUNTIES

	Rates	Fringes
TRUCK DRIVER		
Group 1.....	\$ 36.26	18.51
Group 2.....	\$ 36.77	18.51
Group 3.....	\$ 37.05	18.51
Group 4.....	\$ 37.36	18.51
Group 5.....	\$ 38.35	18.51

CLASSIFICATIONS:

GROUP 1: Drivers on 2 axles hauling less than 9 tons; air compressor & welding machines and brooms, including those pulled by separate units; Truck Driver Helper, warehouse employees; Mechanic Helpers; greasers and tiremen; pick-up trucks when hauling material, tools, or workers to and from and on the job site; and forklifts up to 6,000 lb capacity.

GROUP 2: 2 or 3 axles hualing more than 9 tons but hauling less than 16 tons; A-frame winch trucks; hydrolift trucks; Vactor Trucks or similar equipment when used for transportation purposes; Forklift over 6,000 lb.capacity; winch trucks; and four axle combiation units.

GROUP 3: 2, 3 or 4 Axles hauling 16 tons or more; 5-Axles or more combination units; drivers on water pulls; articulated dump trucks; mechanics and working forepersons.

GROUP 4: Low Boy and Oil Distributors.

GROUP 5: Drivers who require special protective clothing while employed on hazardous waste work.

TEAM0627-004 05/01/2017

PEORIA, TAZEWELL, and WOODFORD COUNTIES

	Rates	Fringes
TRUCK DRIVER		
Group 1.....	\$ 36.15	18.30
Group 2.....	\$ 36.67	18.30
Group 3.....	\$ 36.91	18.30
Group 4.....	\$ 37.25	18.30
Group 5.....	\$ 38.23	18.30

CLASSIFICATIONS:

GROUP 1: Drivers on 2 axles hauling less than 9 tons; air compressor & welding machines and brooms, including those pulled by separate units; Truck Driver Helper, warehouse employees; Mechanic Helpers; greasers and tiremen; pick-up trucks when hauling material, tools, or workers to and from and on the job site; and forklifts up to 6,000 lb capacity.

GROUP 2: 2 or 3 axles hualing more than 9 tons but hauling less than 16 tons; A-frame winch trucks; hydrolift trucks; Vactor Trucks or similar equipment when used for transportation purposes; Forklift over 6,000 lb.capacity; winch trucks; and four axle combiation units.

GROUP 3: 2, 3 or 4 Axles hauling 16 tons or more; 5-Axles or more combination units; drivers on water pulls; articulated dump trucks; mechanics and working forepersons.

GROUP 4: Low Boy and Oil Distributors.

GROUP 5: Drivers who require special protective clothing while employed on hazardous waste work.

* TEAM0673-003 06/01/2017

DU PAGE and KANE COUNTIES

	Rates	Fringes
TRUCK DRIVER		
2-3 AXLES.....	\$ 36.93	0.15+a
4 AXLES.....	\$ 37.08	0.15+a
5 AXLES.....	\$ 37.28	0.15+a
6 AXLES.....	\$ 37.48	0.15+a

FOOTNOTE: a. \$767.70 per week.

An additional \$.20 per axle shall be paid for all vehicles with more than six (6) axles.

Paid Holidays: New Year's Day, Memorial Day, Independence Day, Labor Day, Thanksgiving Day, and Christmas Day.

900 straight time hours or more in 1 calendar year for the same employer shall receive 1 week paid vacation; 3 years - 2 weeks paid vacation; 10 years - 3 weeks paid vacation; 20 years - 4 weeks paid vacation.

CLASSIFICATIONS:

Group 1 - Frame Truck when used for transportation purposes; Air Compressor and Welding Machines, including those pulled by cars, pick-up trucks and tractors; Ambulances; Articulated Dumps; Batch Gate Lockers; Batch Hopperman; Car and Truck Washers; Carry Alls; Forl Lifts and Hoisters; Helpers; Mechanics Helpers and Greasers; Oil Distributors, two-man operation; Pavement Breakers; Pole Trailer, up to 40 feet; Pothole Repair Trucks; Power Mower Tractors; Quick Change Barrier; Self-Propelled Chip Spreader; Shipping and Receiving Clerks and Checkers; Skipman; Slurry Trucks, two-man operation; Slurry Trucks, Conveyor Operated - 2 or 3 man operation; Teamsters; Unskilled Dumpmen; Warehousemen and Dockmen; Truck Drivers hauling warning lights, barricades, and portable toilets on the job site

Group 2 - Dispatcher; Dump Crets and Adgetators under 7 yards; Dumpsters, Track Trucks, Euclids, Hug Bottom Dump Turnapulls or Turnatrailers when pulling other than self-loading equipment or similar equipment under 16 cubic yards; Mixer Trucks under 7 yards; Ready-Mix Plant Hopper Operator; Winch Trucks, 2 Axles

Group 3 - Dump Crets and Adgetators, 7 yards and over; Dumpsters, Track Trucks, Euclids, Hug Bottom Dump Turnapulls or Turnatrailers when pulling other than self-loading equipment or similar equipment over 16 cubic yards; Explosives and/or Fission Material Trucks; Mixer Trucks 7 yards or over; Mobile Cranes while in transit; Oil Distributors, one-man operation; Pole Trailer, over 40 feet; Pole and Expandable Trailers hauling material over 50 feet long; Slurry Trucks, one-man operation; Winch Trucks, 3 axles or more; Mechanic - *Truck Welder and *Truck Painter*These classifications shall only apply in areas where and when it has been a past area practice; Asphalt Plant Operators in areas where it has been past practice

Group 4 - Dual-purpose vehicels, such as mounted crane tucks with hoist and accessories; Foreman; Master Mechanic; Self-loading equipment like P.B. and trucks with scoops on the front

TEAM0722-005 05/01/2015

OGLE (North of Route 72/East of Route 251) COUNTY

	Rates	Fringes
TRUCK DRIVER		
Group 1.....	\$ 34.10	17.09
Group 2.....	\$ 34.60	17.09
Group 3.....	\$ 34.82	17.09

Group 4.....	\$ 35.14	17.09
Group 5.....	\$ 36.06	17.09

CLASSIFICATIONS:

GROUP 1: Drivers on 2 axles hauling less than 9 tons; air compressor & welding machines and brooms, including those pulled by separate units; Truck Driver Helper, warehouse employees; Mechanic Helpers; greasers and tiremen; pick-up trucks when hauling material, tools, or workers to and from and on the job site; and forklifts up to 6,000 lb capacity.

GROUP 2: 2 or 3 axles hauling more than 9 tons but hauling less than 16 tons; A-frame winch trucks; hydrolift trucks; Vactor Trucks or similar equipment when used for transportation purposes; Forklift over 6,000 lb.capacity; winch trucks; and four axle combination units.

GROUP 3: 2, 3 or 4 Axles hauling 16 tons or more; 5-Axles or more combination units; drivers on water pulls; articulated dump trucks; mechanics and working forepersons.

GROUP 4: Low Boy and Oil Distributors.

GROUP 5: Drivers who require special protective clothing while employed on hazardous waste work.

TEAM0731-001 06/01/2017

COOK COUNTY - HEAVY AND HIGHWAY

	Rates	Fringes
TRUCK DRIVER		
2 or 3 Axles.....	\$ 35.60	22.10
4 Axles.....	\$ 35.85	22.10
5 Axles.....	\$ 36.05	22.10
6 Axles.....	\$ 36.25	22.10

FOOTNOTES:

- A. Paid Holidays: New Year's Day, Memorial Day, Independence Day, Labor Day, Thanksgiving Day, and Christmas Day.
- B. 900 straight time hours or more in 1 calendar year for the same employer shall receive 1 week paid vacation; 3 years - 2 weeks paid vacation; 10 years - 3 weeks paid vacation; 20 years - 4 weeks paid vacation.
- C. An additional \$.20 per axle shall be paid for all vehicles with more than six (6) axles.

TEAM0786-001 06/01/2017

COOK COUNTY - BUILDING AND RESIDENTIAL

	Rates	Fringes
TRUCK DRIVER		
2 & 3 Axles.....	\$ 39.942	0.25+a
4 Axles.....	\$ 39.75	0.25+a
5 Axles.....	\$ 39.967	0.25+a
6 Axles.....	\$ 40.184	0.25+a

FOOTNOTES:

- a. \$719.00 per week.
- An additional \$.20 per axle shall be paid for all vehicles with more than six (6) axles.
- Paid Holidays: New Year's Day, Memorial Day, Independence Day, Labor Day, Thanksgiving Day, and Christmas Day.
- 900 straight time hours or more in 1 calendar year for the same employer shall receive 1 week paid vacation; 3 years - 2 weeks paid vacation; 10 years - 3 weeks paid vacation; 20 years - 4 weeks paid vacation.

SUIL1993-001 01/19/1993

BUILDING CONSTRUCTION (LANDSCAPE WORK):

	Rates	Fringes
LABORER		

BOONE, GRUNDY, KANE, KENDALL, LAKE, MCHENRY, & WILL COUNTIES		
LANDSCAPE LABORERS.....\$	7.25	
COOK COUNTY		
LANDSCAPE LABORERS.....\$	7.25	
LANDSCAPE PLANTSMAN.....\$	9.80	1.82
DE KALB COUNTY		
LANDSCAPE LABORERS.....\$	7.25	
LANDSCAPE OPERATORS.....\$	7.25	
LANDSCAPE PLANTSMAN.....\$	9.66	.26
DU PAGE COUNTY		
LANDSCAPE LABORERS.....\$	7.25	
LANDSCAPE PLANTSMAN.....\$	9.04	1.16
GRUNDY, LAKE & WILL COUNTIES		
LANDSCAPE DRIVER 2 & 3		
Axles.....\$	11.86	2.81
LANDSCAPE PLANTSMAN.....\$	12.00	3.32

SUIL1993-002 01/19/1993

HEAVY CONSTRUCTION (LANDSCAPE WORK)

	Rates	Fringes
LABORER		
BOONE, GRUNDY, KANE, KENDALL, LAKE, MCHENRY & WILL COUNTIES:		
LANDSCAPE DRIVER, 2 & 3		
AXLES.....\$	11.94	2.42
LANDSCAPE LABORERS.....\$	7.25	
LANDSCAPE OPERATORS.....\$	13.11	3.01
LANDSCAPE PLANTSMAN.....\$	9.73	2.05
COOK COUNTY:		
LANDSCAPE DRIVER, 2 & 3		
AXLES.....\$	9.93	1.89
LANDSCAPE LABORERS.....\$	7.25	
LANDSCAPE OPERATORS.....\$	10.98	2.12
LANDSCAPE PLANTSMAN.....\$	10.08	2.06
DE KALB COUNTY:		
LANDSCAPE LABORERS.....\$	7.25	
LANDSCAPE OPERATORS.....\$	7.25	
LANDSCAPE PLANTSMAN.....\$	9.66	.26
DU PAGE COUNTY:		
LANDSCAPE DRIVER, 2 & 3		
AXLES.....\$	8.32	1.02
LANDSCAPE LABORERS.....\$	7.25	
LANDSCAPE OPERATORS.....\$	10.75	
LANDSCAPE PLANTSMAN.....\$	10.65	

SUIL1993-003 01/19/1993

HIGHWAY CONSTRUCTION (LANDSCAPE WORK):

	Rates	Fringes
LABORER		
DE KALB COUNTY		
LANDSCAPE LABORERS.....\$	7.25	
LANDSCAPE OPERATORS.....\$	7.25	
LANDSCAPE PLANTSMAN.....\$	9.66	.26
KANKAKEE COUNTY:		
LANDSCAPE DRIVER.....\$	8.75	.17
LANDSCAPE OPERATOR.....\$	16.57	3.56
PEORIA, TAZEWELL, & WOODFORD COUNTIES:		
TRUCK DRIVERS 2 & 3 AXLES..\$	17.58	5.88

WELDERS - Receive rate prescribed for craft performing
operation to which welding is incidental.

=====
Note: Executive Order (EO) 13706, Establishing Paid Sick Leave for Federal Contractors applies to all contracts subject to the Davis-Bacon Act for which the contract is awarded (and any solicitation was issued) on or after January 1, 2017. If this contract is covered by the EO, the contractor must provide employees with 1 hour of paid sick leave for every 30 hours they work, up to 56 hours of paid sick leave each year. Employees must be permitted to use paid sick leave for their own illness, injury or other health-related needs, including preventive care; to assist a family member (or person who is like family to the employee) who is ill, injured, or has other health-related needs, including preventive care; or for reasons resulting from, or to assist a family member (or person who is like family to the employee) who is a victim of, domestic

violence, sexual assault, or stalking. Additional information on contractor requirements and worker protections under the EO is available at www.dol.gov/whd/govcontracts.

Unlisted classifications needed for work not included within the scope of the classifications listed may be added after award only as provided in the labor standards contract clauses (29CFR 5.5 (a) (1) (ii)).

The body of each wage determination lists the classification and wage rates that have been found to be prevailing for the cited type(s) of construction in the area covered by the wage determination. The classifications are listed in alphabetical order of "identifiers" that indicate whether the particular rate is a union rate (current union negotiated rate for local), a survey rate (weighted average rate) or a union average rate (weighted union average rate).

Union Rate Identifiers

A four letter classification abbreviation identifier enclosed in dotted lines beginning with characters other than "SU" or "UAVG" denotes that the union classification and rate were prevailing for that classification in the survey. Example: PLUM0198-005 07/01/2014. PLUM is an abbreviation identifier of the union which prevailed in the survey for this classification, which in this example would be Plumbers. 0198 indicates the local union number or district council number where applicable, i.e., Plumbers Local 0198. The next number, 005 in the example, is an internal number used in processing the wage determination. 07/01/2014 is the effective date of the most current negotiated rate, which in this example is July 1, 2014.

Union prevailing wage rates are updated to reflect all rate changes in the collective bargaining agreement (CBA) governing this classification and rate.

Survey Rate Identifiers

Classifications listed under the "SU" identifier indicate that no one rate prevailed for this classification in the survey and the published rate is derived by computing a weighted average rate based on all the rates reported in the survey for that classification. As this weighted average rate includes all rates reported in the survey, it may include both union and non-union rates. Example: SULA2012-007 5/13/2014. SU indicates the rates are survey rates based on a weighted average calculation of rates and are not majority rates. LA indicates the State of Louisiana. 2012 is the year of survey on which these classifications and rates are based. The next number, 007 in the example, is an internal number used in producing the wage determination. 5/13/2014 indicates the survey completion date for the classifications and rates under that identifier.

Survey wage rates are not updated and remain in effect until a new survey is conducted.

Union Average Rate Identifiers

Classification(s) listed under the UAVG identifier indicate that no single majority rate prevailed for those classifications; however, 100% of the data reported for the classifications was union data. EXAMPLE: UAVG-OH-0010 08/29/2014. UAVG indicates that the rate is a weighted union average rate. OH indicates the state. The next number, 0010 in the example, is an internal number used in producing the wage determination. 08/29/2014 indicates the survey completion date for the classifications and rates under that identifier.

A UAVG rate will be updated once a year, usually in January of each year, to reflect a weighted average of the current negotiated/CBA rate of the union locals from which the rate is based.

WAGE DETERMINATION APPEALS PROCESS

1.) Has there been an initial decision in the matter? This can be:

- * an existing published wage determination
- * a survey underlying a wage determination

- * a Wage and Hour Division letter setting forth a position on a wage determination matter
- * a conformance (additional classification and rate) ruling

On survey related matters, initial contact, including requests for summaries of surveys, should be with the Wage and Hour Regional Office for the area in which the survey was conducted because those Regional Offices have responsibility for the Davis-Bacon survey program. If the response from this initial contact is not satisfactory, then the process described in 2.) and 3.) should be followed.

With regard to any other matter not yet ripe for the formal process described here, initial contact should be with the Branch of Construction Wage Determinations. Write to:

Branch of Construction Wage Determinations
 Wage and Hour Division
 U.S. Department of Labor
 200 Constitution Avenue, N.W.
 Washington, DC 20210

2.) If the answer to the question in 1.) is yes, then an interested party (those affected by the action) can request review and reconsideration from the Wage and Hour Administrator (See 29 CFR Part 1.8 and 29 CFR Part 7). Write to:

Wage and Hour Administrator
 U.S. Department of Labor
 200 Constitution Avenue, N.W.
 Washington, DC 20210

The request should be accompanied by a full statement of the interested party's position and by any information (wage payment data, project description, area practice material, etc.) that the requestor considers relevant to the issue.

3.) If the decision of the Administrator is not favorable, an interested party may appeal directly to the Administrative Review Board (formerly the Wage Appeals Board). Write to:

Administrative Review Board
 U.S. Department of Labor
 200 Constitution Avenue, N.W.
 Washington, DC 20210

4.) All decisions by the Administrative Review Board are final.

=====

END OF GENERAL DECISION

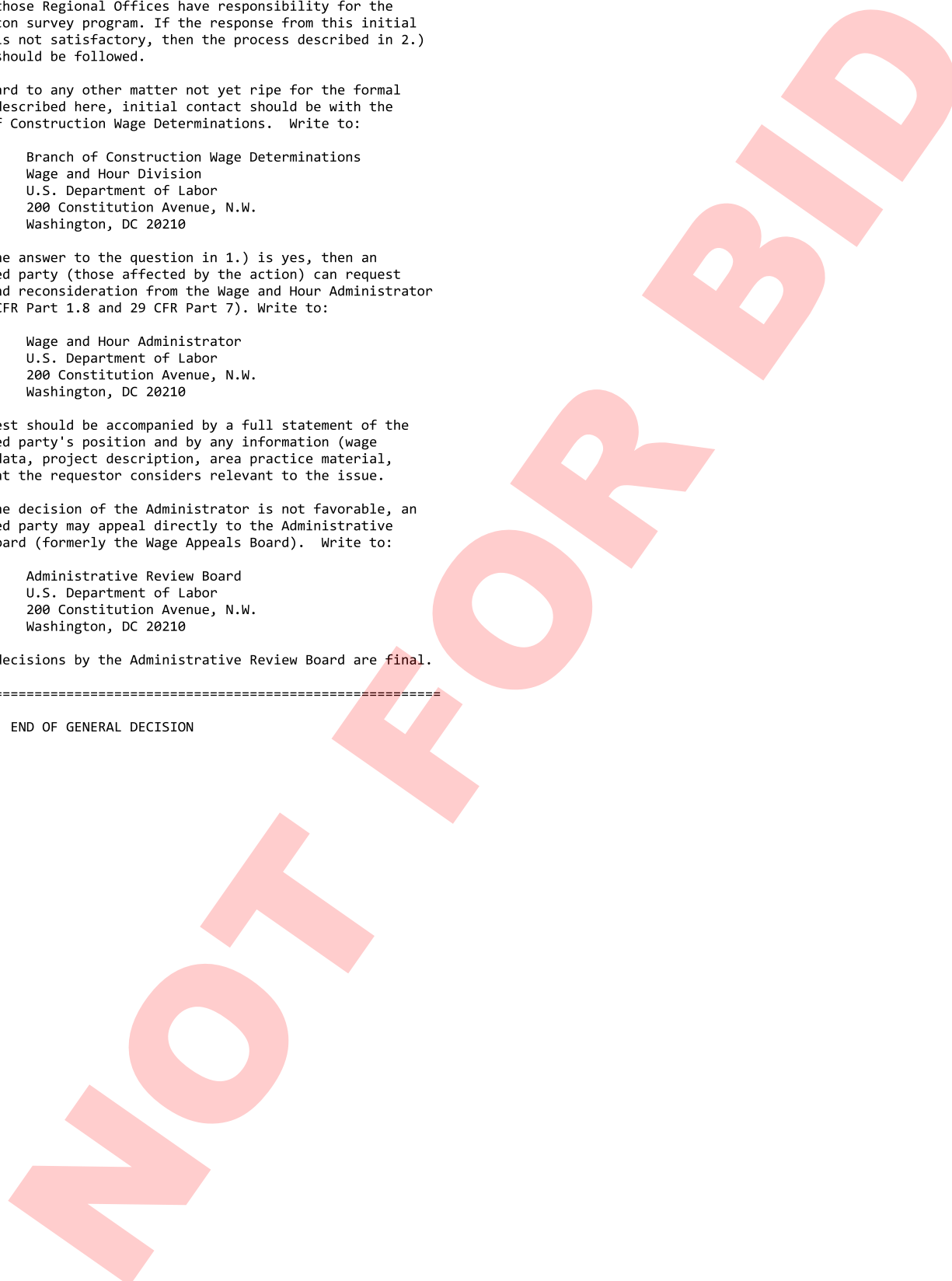

**SECOND AVENUE SEWER SEPARATION
VILLAGE OF VILLA PARK**

APPENDIX B

IRMA CONTRACTUAL INSURANCE GUIDELINES

NOT FOR BID

NOT FOR BID

IRMA

CONTRACTUAL INSURANCE GUIDELINES

I. INSURANCE REQUIREMENTS

Contractor shall procure and maintain, for the duration of the contract, insurance against claims for injuries to persons or damages to property, which may arise from or in connection with the performance of the work hereunder by the Contractor, his agents, representatives, employees or subcontractors.

MINIMUM SCOPE OF INSURANCE

Coverage shall be at least as broad as:

- A. Insurance Services Office Commercial General Liability occurrence form CG 0001 with the member named as additional insured, on a form at least as broad as the attached sample endorsement including ISO Additional Insured Endorsement CG 2010 (Exhibit A), CG 2026 (Exhibit B).

CG2037 - Completed Operations – (Exhibit C)
Required if box is checked ; and

- B. Owners and Contractors Protective Liability (OCP) policy with the member as insured

Required if box is checked ; and

- C. Insurance Service Office Business Auto Liability coverage form number CA 0001, Symbol 01 "Any Auto."

- D. Workers' Compensation as required by the Workers' Compensation Act of the State of Illinois and Employers' Liability insurance.

Coverage required for employee exposure to lead, if box is checked

- E. Builder Risk Property Coverage with member as loss payee

Required if box is checked .

- F. Environmental Impairment/Pollution Liability Coverage for pollution incidents as a result of a claim for bodily injury, property damage or remediation costs from an incident at, on or migrating beyond the contracted work site. Coverage shall be extended to Non-Owned Disposal sites resulting from a pollution incident at, on or mitigating beyond the site; and also provide coverage for incidents occurring during transportation of pollutants.

Required if box is checked .

MINIMUM LIMITS OF INSURANCE

Contractor shall maintain limits no less than the following, **if required under above scope**:

- A. Commercial General Liability: \$1,000,000 combined single limit per occurrence for bodily injury, and property damage and \$1,000,000 per occurrence for personal injury. The general aggregate shall be twice the required occurrence limit. Minimum General Aggregate shall be no less than \$2,000,000 or a project/contract specific aggregate of \$1,000,000.

- B. Owners and Contractors Protective Liability (OCP): \$1,000,000 combined single limit per occurrence for bodily injury and property damage.
- C. Business Automobile Liability: \$1,000,000 combined single limit per accident for bodily injury and property damage.
- D. Workers' Compensation and Employers' Liability: Workers' Compensation coverage with statutory limits and Employers' Liability limits of \$500,000 per accident.
- E. Builder's Risk: Shall insure against "All Risk" of physical damage, including water damage (flood and hydrostatic pressure not excluded), on a completed replacement cost basis.
- F. Environmental Impairment/Pollution Liability: \$1,000,000 combined single limit per occurrence for bodily injury, property damage and remediation costs.

DEDUCTIBLES AND SELF-INSURED RETENTIONS

Any deductibles or self-insured retentions must be declared to and approved by the member. At the option of the member, either: the insurer shall reduce or eliminate such deductibles or self-insured retentions as respects the member, its officials, employees, agents and volunteers; or the Contractor shall procure a bond guaranteeing payment of losses and related investigation, claim administration and defense expenses.

OTHER INSURANCE PROVISIONS

The policies are to contain, or be endorsed to contain, the following provisions:

A. General Liability and Automobile Liability Coverages

1. The member, its officials, agents, employees and volunteers are to be covered as additional insureds as respects: liability arising out of the Contractor's work, including activities performed by or on behalf of the Contractor; products and completed operations of the Contractor; premises owned, leased or used by the Contractor; or automobiles owned, leased, hired or borrowed by the Contractor. The coverage shall contain no special limitations on the scope of protection afforded to the member, its officials, agents, employees and volunteers.
2. The Contractor's insurance coverage shall be primary as respects the member, its officials, employees, agents and volunteers. Any insurance or self-insurance maintained by the member, its officials, agents, employees and volunteers shall be excess of Contractor's insurance and shall not contribute with it.
3. Any failure to comply with reporting provisions of the policies shall not affect coverage provided to the member, its officials, employees, agents and volunteers.
4. The Contractor's insurance shall contain a Severability of Interests/Cross Liability clause or language stating that Contractor's insurance shall apply separately to each insured against whom claim is made or suit is brought, except with respect to the limits of the insurer's liability.
5. If any commercial general liability insurance is being provided under an excess

or umbrella liability policy that does not “follow form,” then the Contractor shall be required to name the member, its officials, employees, agents and volunteers as additional insureds.

6. All general liability coverages shall be provided on an occurrence policy form. Claims-made general liability policies will not be accepted.
7. The contractor and all subcontractors hereby agree to waive any limitation as to the amount of contribution recoverable against them by member. This specifically includes any limitation imposed by any state statute, regulation, or case law including any Workers’ Compensation Act provision that applies a limitation to the amount recoverable in contribution such as Kotecki v. Cyclops Welding.

B. Workers' Compensation and Employers' Liability Coverage

The insurer shall agree to waive all rights of subrogation against the member, its officials, employees, agents and volunteers for losses arising from work performed by Contractor for the municipality.

1. NCCI Alternate Employer Endorsement (WC 000301) in place to insure that workers’ compensation coverage applies under contractor’s coverage rather than member’s if the member is borrowing, leasing or in day to day control of contractors employee.

Required if box is checked .

C. Professional Liability (Required if box is checked)

1. Professional liability insurance with limits not less than \$1,000,00 each claim with respect to negligent acts, errors and omissions in connection with professional services to be provided under the contract, with a deductible not-to-exceed \$50,000 without prior written approval.
2. If the policy is written on a claims-made form, the retroactive date must be equal to or preceding the effective date of the contract. In the event the policy is cancelled, non-renewed or switched to an occurrence form, the Contractor shall be required to purchase supplemental extending reporting period coverage for a period of not less than three (3) years.
3. Provide a certified copy of actual policy for review.
4. Recommended Required Coverage (architect, engineer, surveyor, consultant): Professional liability insurance that provides indemnification and defense for injury or damage arising out of acts, errors, or omissions in providing the following professional services, but not limited to the following:
 - a. Preparing, approving or failure to prepare or approve maps, drawings, opinions, report, surveys, change orders, designs or specifications;
 - b. Providing direction, instruction, supervision, inspection, engineering services or failing to provide them, if that is the primary cause of injury or damage.

D. All Coverages

Each insurance policy required shall have the member expressly endorsed onto the policy as a Cancellation Notice Recipient. Should any of the policies be cancelled before the expiration date thereof, notice will be delivered in accordance with the policy provisions.

ACCEPTABILITY OF INSURERS

Insurance is to be placed with insurers with a Best's rating of no less than A-, VII and licensed to do business in the State of Illinois.

VERIFICATION OF COVERAGE

Contractor shall furnish the member with certificates of insurance naming the member, its officials, employees, agents and volunteers as additional insureds (Exhibit D), and with original endorsements affecting coverage required by this clause. The certificates and endorsements for each insurance policy are to be signed by a person authorized by that insurer to bind coverage on its behalf. The certificates and endorsements are to be received and approved by the member before any work commences. The following additional insured endorsements may be utilized: ISO Additional Insured Endorsements CG 2010 (Exhibit A) or CG 2026 (Exhibit B), and CG 2037 (Exhibit C) – Completed Operations, where required. The member reserves the right to request full certified copies of the insurance policies and endorsements.

SUBCONTRACTORS

Contractor shall include all subcontractors as insureds under its policies or shall furnish separate certificates and endorsements for each subcontractor. All coverages for subcontractors shall be subject to all of the requirements stated herein.

ASSUMPTION OF LIABILITY

The contractor assumes liability for all injury to or death of any person or persons including employees of the contractor, any sub-contractor, any supplier or any other person and assumes liability for all damage to property sustained by any person or persons occasioned by or in any way arising out of any work performed pursuant to this agreement.

II. INDEMNITY/HOLD HARMLESS PROVISION

To the fullest extent permitted by law, the Contractor hereby agrees to defend, indemnify and hold harmless the member, its officials, employees and agents against all injuries, deaths, loss, damages, claims, patent claims, suits, liabilities, judgments, cost and expenses, which may in anywise accrue against the member, its officials, agents and employees, arising in whole or in part or in consequence of the performance of this work by the Contractor, its employees, or subcontractors, or which may in anywise result therefore, except that arising out of the sole legal cause of the member, its employees or agents, the Contractor shall, at its own expense, appear, defend and pay all charges of attorneys and all costs and other expenses arising therefore or incurred in connections therewith, and, if any judgment shall be rendered against the member, its officials, employees and agents, in any such action, the Contractor shall, at its own expense, satisfy and discharge the same.

Contractor expressly understands and agrees that any performance bond or insurance policies required by this contract, or otherwise provided by the Contractor, shall in no way limit the responsibility to indemnify, keep and save harmless and defend the member, its

officials, employees and agents as herein provided.

The Contractor further agrees that to the extent that money is due the Contractor by virtue of this contract as shall be considered necessary in the judgment of the member, may be retained by the member to protect itself against said loss until such claims, suits, or judgments shall have been settled or discharged and/or evidence to that effect shall have been furnished to the satisfaction of the member.

III. SAFETY/LOSS PREVENTION

Safety/Loss Prevention Program Requirements

- Successful bidder will provide written confirmation that a safety/loss prevention program was in place at least 90 days prior to submitting the bid proposal.
- Evidence of completed employee safety training can be provided.

Regulatory Requirements

- Successful bidder must comply with all applicable laws, regulations, and rules promulgated by any Federal, State, County, Municipal and/or other governmental unit or regulatory body now in effect or which may be in effect during the performance of the work. Included within the scope of the laws, regulations, and rules referred to in this paragraph but in no way to operate as a limitation, are Occupational Safety & Health Act (OSHA), Illinois Department of Labor (IDOL), Department of Transportation, all forms of traffic regulations, public utility, Intrastate and Interstate Commerce Commission regulations, Workers' Compensation Laws, Prevailing Wage Laws, the Social Security Act of the Federal Government and any of its titles, the Illinois Department of Human Rights, Human Rights Commission, or EEOC statutory provisions and rules and regulations.
- Evidence of specific regulatory compliance will be provided by bidder, if required by owner.

EXHIBIT A

POLICY NUMBER:

COMMERCIAL GENERAL LIABILITY
CG 20 10 07 04

THIS ENDORSEMENT CHANGES THE POLICY. PLEASE READ IT CAREFULLY.

**ADDITIONAL INSURED – OWNERS, LESSEES OR
CONTRACTORS – SCHEDULED PERSON OR
ORGANIZATION**

This endorsement modifies insurance provided under the following:

COMMERCIAL GENERAL LIABILITY COVERAGE PART

SCHEDULE

Name Of Additional Insured Person(s) Or Organization(s):	Location(s) Of Covered Operations
Information required to complete this Schedule, if not shown above, will be shown in the Declarations.	

A. Section II – Who Is An Insured is amended to include as an additional insured the person(s) or organization(s) shown in the Schedule, but only with respect to liability for "bodily injury," "property damage" or "personal and advertising injury" caused, in whole or in part, by:

1. Your acts or omissions; or
2. The acts or omissions of those acting on your behalf;

in the performance of your ongoing operations for the additional insured(s) at the location(s) designated above.

B. With respect to the insurance afforded to these additional insureds, the following additional exclusions apply:

This insurance does not apply to "bodily injury" or "property damage" occurring after:

1. All work, including materials, parts or equipment furnished in connection with such work, on the project (other than service, maintenance or repairs) to be performed by or on behalf of the additional insured(s) at the location of the covered operations has been completed; or
2. That portion of "your work" out of which the injury or damage arises has been put to its intended use by any person or organization other than another contractor or subcontractor engaged in performing operations for a principal as a part of the same project.

EXHIBIT
C

POLICY NUMBER:

COMMERCIAL GENERAL LIABILITY
CG 20 37 07 04

THIS ENDORSEMENT CHANGES THE POLICY. PLEASE READ IT CAREFULLY.

**ADDITIONAL INSURED – OWNERS, LESSEES OR
CONTRACTORS – COMPLETED OPERATIONS**

This endorsement modifies insurance provided under the following:

COMMERCIAL GENERAL LIABILITY COVERAGE PART

SCHEDULE

Name Of Additional Insured Person(s) Or Organization(s):	Location And Description Of Completed Operations

Information required to complete this Schedule, if not shown above, will be shown in the Declarations.

Section II – Who Is An Insured is amended to include as an additional insured the person(s) or organization(s) shown in the Schedule, but only with respect to liability for "bodily injury" or "property damage" caused, in whole or in part, by "your work" at the location designated and described in the schedule of this endorsement performed for that additional insured and included in the "products-completed operations hazard".

NOT FOR BID

**SECOND AVENUE SEWER SEPARATION
VILLAGE OF VILLA PARK**

APPENDIX C

VILLAGE OF VILLA PARK ORDINANCE 3733

NOT FOR BID

NOT FOR BID

AN ORDINANCE OF THE VILLAGE OF VILLA PARK, DUPAGE COUNTY, ILLINOIS AMENDING THE REQUIREMENTS OF BIDDERS FOR CONSTRUCTION PROJECTS

WHEREAS, the Village of Villa Park (the “*Village*”) is a duly organized and validly existing non home-rule municipality created in accordance with the Constitution of the State of Illinois of 1970 and the laws of the State; and,

WHEREAS, section 8-9-1 of the Illinois Municipal Code (65 ILCS 5/8-9-2) allows the Village to require competitive bidding after advertising for bids in the manner prescribed by ordinance; and,

WHEREAS, the President and Board of Trustees desire to adopt purchasing procedures to provide for additional requirements of bidders for construction projects to have active apprenticeship and training programs approved and registered with the United States Department of Labor’s Bureau of Apprenticeship and Training and to have bidders show three similar projects they constructed within the last five years.

NOW, THEREFORE, BE IT ORDAINED by the President and Board of Trustees of the Village of Villa Park, DuPage County, Illinois, as follows:

Section 1. That Section 2-219 of the Villa Park Municipal Code, as amended, be and is hereby amended by placing the existing text as subsection A. and adding a new subsection B. to read as follows:

“B. A responsible bidder for the construction of public works projects shall meet and submit evidence of compliance with the following requirements:

- (1) All applicable laws prerequisite to doing business in the State of Illinois,
- (2) A federal employer tax identification number or social security number,
- (3) Provision of Section 2000(e) of Chapter 21, Title 42 of the United States Code and Federal Executive Order No. 11246 as amended by Executive Order No. 11375 (known as the Equal Opportunity Employer provisions),
- (4) Certificates of insurance indicating the following coverage’s: general liability, worker’s compensation, completed operations, automobile, hazardous occupation and product liability
- (5) Compliance with all provisions of the Illinois Prevailing Wage Act, including wages, medical and hospitalization insurance and retirement for those trades covered in the Act,
- (6) The bidder and all bidder’s sub-contractors must participate in active apprenticeship and training programs approved and registered with the United States Department of Labor’s Bureau of Apprenticeship and Training for each of the trades of work contemplated under the proposed contract,
- (7) All contractors and sub-contractors are required to file certified payrolls as specified in Illinois Public Act 94-0515, and follow all provisions of the Employee Classification Act (820 ILCS 185/1 et seq.), and

(8) All bidders must provide three (3) projects of a similar nature constructed in the immediate past five (5) years with the name, address and telephone number of the contact person having knowledge of the project along with three (3) references (name, address, and telephone number) with knowledge of the integrity and business practices of the bidder.”

Section 2. This Ordinance shall be in full force and effect upon its passage, approval, and publication as provided by law.

Passed this 11 day of February, 2013.

AYES: ALL

NAYS: Aiello Bulthuis

ABSENT: _____

Approved this 11 day of February, 2013.



Village President

Attest:

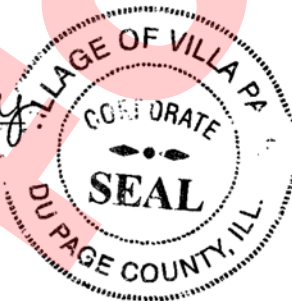
Village Clerk



Published in pamphlet form:

2-11, 2013