

VILLAGE OF VILLA PARK DUPAGE COUNTY, ILLINOIS 2016 STREET IMPROVEMENTS

F.A. RTE.	SECTION	COUNTY	TOTAL SHEETS	SHEET NO.
		DUPAGE	62	1
ILLINOIS CONTRACT NO.				

ALL LOCATION MAPS
(NOT TO SCALE)

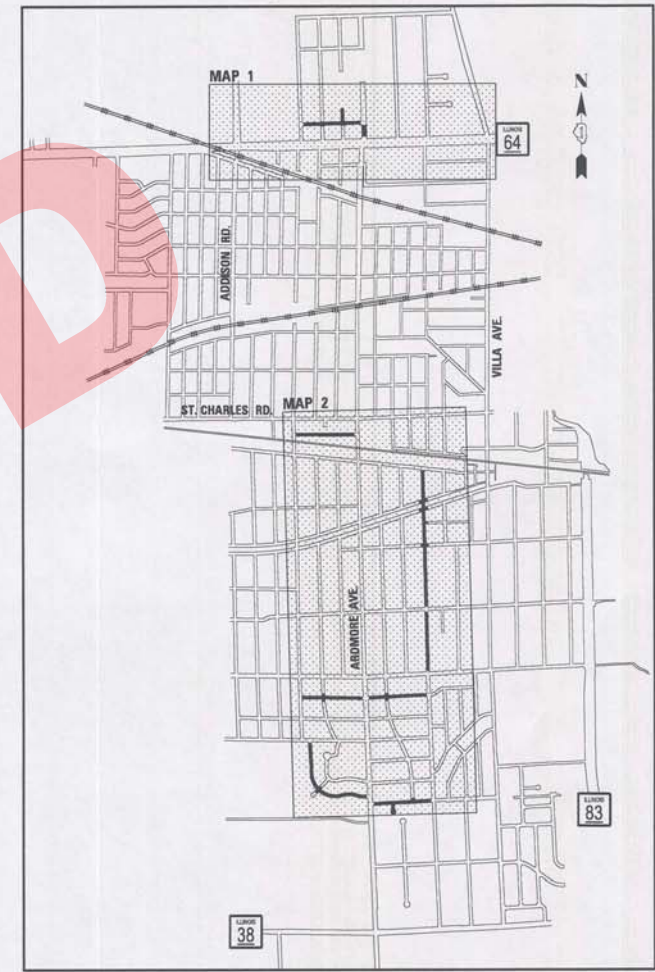

FOR INDEX OF SHEETS, SEE SHEET NO. 2



VILLAGE BOARD

- PRESIDENT DEBORAH BULLWINKEL
- TRUSTEE CHRIS J. AIELLO
- TRUSTEE ALBERT BULTHUIS
- TRUSTEE NICK CUZZONE
- TRUSTEE DONALD KASE
- TRUSTEE ROBERT TAGLIA
- TRUSTEE ROBERT WAGNER

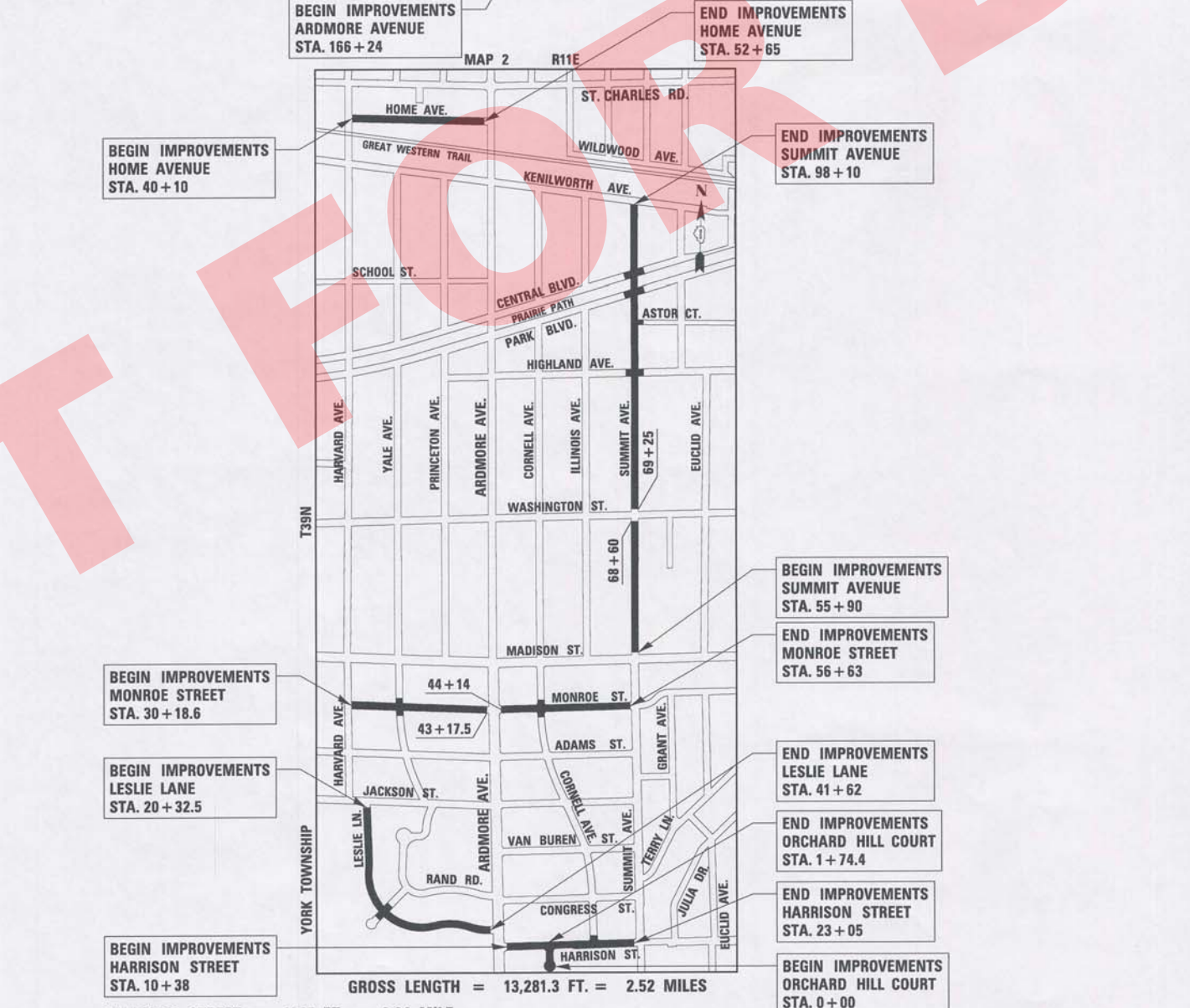

GROSS LENGTH = 13,281.3 FT. = 2.52 MILES

HARRISON STREET = 1267 FT. = 0.24 MILE	HOME AVENUE = 1255 FT. = 0.24 MILE
ORCHARD HILL COURT = 174.4 FT. = 0.03 MILE	WILDFIRE DRIVE = 1244 FT. = 0.24 MILE
LESLIE LANE = 2129.5 FT. = 0.40 MILE	PRINCETON AVENUE = 261.5 FT. = 0.05 MILE
MONROE STREET = 2547.9 FT. = 0.48 MILE	ARDMORE AVENUE = 247 FT. = 0.05 MILE
SUMMIT AVENUE = 4155 FT. = 0.79 MILE	

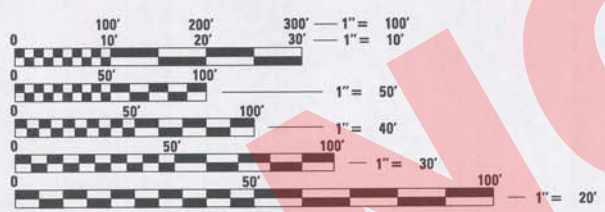

FULL SIZE PLANS HAVE BEEN PREPARED USING STANDARD ENGINEERING SCALES. REDUCED SIZED PLANS WILL NOT CONFORM TO STANDARD SCALES. IN MAKING MEASUREMENTS ON REDUCED PLANS, THE ABOVE SCALES MAY BE USED.

J.U.L.I.E.
JOINT UTILITY LOCATION INFORMATION FOR EXCAVATION
1-800-892-0123
OR 811



Derek N. Mall
REGISTERED P.E., STATE OF ILLINOIS
NO. 062-051308; EXPIRES 11-30-2017



PLANS PREPARED BY:

CIVILTECH
450 E. Devon Ave, Suite 300 - Itasca, Illinois 60143
Tel: 630.773.3900 - Fax: 630.773.3975
www.civiltechinc.com

STATE OF ILLINOIS
VILLAGE OF VILLA PARK

APPROVED APRIL 15 20 16

Vydas Juskelis VYDAS JUSKELIS, P.E.
PUBLIC WORKS DIRECTOR, VILLAGE OF VILLA PARK

PLOT DRIVER = ...\\vpm\desa2314\..._pdf.plt
PEN TABLE = ...\\vpm\tbl\..._tbl.tbl
FILE NAME = ...3915-ht-...over.dgn

SPECIFICATIONS, STANDARDS AND SPECIAL PROVISIONS

- ALL CONSTRUCTION SHALL BE IN ACCORDANCE WITH THE "STANDARD SPECIFICATIONS FOR ROAD AND BRIDGE CONSTRUCTION" ("STANDARD SPECIFICATIONS"), ADOPTED APRIL 1, 2016; THE "SUPPLEMENTAL SPECIFICATIONS AND RECURRING SPECIAL PROVISIONS", ADOPTED APRIL 1, 2016; THE LATEST EDITION OF THE "ILLINOIS MANUAL ON UNIFORM TRAFFIC CONTROL DEVICES FOR STREETS AND HIGHWAYS" (IMUTCD); THE "STANDARD SPECIFICATIONS FOR WATER AND SEWER CONSTRUCTION IN ILLINOIS", 7TH EDITION, 2014; THE LATEST EDITION OF THE "ILLINOIS URBAN MANUAL"; THE DETAILS IN THE PLANS; AND THE SPECIAL PROVISIONS AND IDOT STANDARD DRAWINGS INCLUDED IN THE CONTRACT DOCUMENTS.
- ALL REFERENCES TO "ENGINEER" SHALL BE INTERPRETED AS THE RESIDENT ENGINEER.
- ALL UTILITY COMPANIES, SCHOOL DISTRICTS, AND LOCAL POLICE AND FIRE DEPARTMENTS SHALL BE NOTIFIED BY THE CONTRACTOR AT LEAST 72 HOURS PRIOR TO THE START OF CONSTRUCTION.

STAKING

- ALL RADII FOR PROPOSED CURB AND GUTTER ARE TO THE EDGE OF PAVEMENT UNLESS OTHERWISE NOTED.
- THE STATION/OFFSET/ELEVATIONS NOTED FOR ALL DRAINAGE STRUCTURES LOCATED IN THE CURB LINE REFER TO THE POSITION OF THE ADJACENT EDGE OF PAVEMENT. THE CONTRACTOR SHALL BE RESPONSIBLE FOR DETERMINING THE OFFSET NECESSARY FOR EACH STRUCTURE TO SET THE FRAME AND GRATE IN THE PROPER LOCATION. ALL OTHER STRUCTURES ARE DIMENSIONED TO THE CENTER OF STRUCTURE, UNLESS OTHERWISE NOTED.
- PAVEMENT GRADES: THE ELEVATIONS INDICATED ON THE PLANS ARE FINISHED GRADES OF PROPOSED PAVEMENT, UNLESS OTHERWISE INDICATED.
- THE CONTRACTOR SHALL PROTECT AND CAREFULLY PRESERVE ALL SECTION OR SUBSECTION MONUMENTS OR PROPERTY OR REFERENCE MARKERS UNTIL THE VILLAGE, ITS AGENT OR AN AUTHORIZED SURVEYOR HAS WITNESSED OR OTHERWISE REFERENCED THEIR LOCATIONS.

STAKING (LESLIE LN. & SUMMIT AVE.)

- ALTHOUGH SURVEY HAS NOT BEEN COMPLETED FOR THESE ROADWAYS, A PROPOSED CENTERLINE HAS BEEN SHOWN. IN GENERAL, THE CENTERLINE REPRESENTS THE CENTER-OF-ROADWAY AND THE CENTER-OF-ROW. THE PROPOSED CENTERLINE IS ONLY A BEST-FIT APPROXIMATION BASED ON AERIAL IMAGERY. ITS PURPOSE IS ONLY TO PROVIDE A GENERAL LENGTH OF ROADWAY IMPROVEMENTS.
- THE DIMENSIONS SHOWN IN THE PLANS ARE APPROXIMATE BASED ON FIELD INVESTIGATIONS. BY NO MEANS SHOULD THE DIMENSIONS ACT AS AN ABSOLUTE LIMIT OF PROPOSED WORK. THE FINAL LENGTHS AND AREAS OF PROPOSED WORK WILL BE DETERMINED IN THE FIELD BY THE ENGINEER.

PAVING, CURB & GUTTER, AND SIDEWALK

- THE PAVEMENT PATCHING AND CURB AND GUTTER REMOVAL AND REPLACEMENT LOCATIONS SHOWN IN THE PLANS ARE ONLY APPROXIMATIONS MADE DURING THE DESIGN PROCESS BASED ON FIELD INVESTIGATIONS. THE ENGINEER IN THE FIELD SHALL MAKE THE FINAL DETERMINATION ON THE LOCATION OF PAVEMENT PATCHES AND CURB AND GUTTER REMOVAL AND REPLACEMENT.
- THE CONTRACTOR SHALL SAW CUT PAVEMENT, CURB & GUTTER, DRIVEWAY AND SIDEWALK AS INDICATED ON THE PLANS TO SEPARATE THE EXISTING MATERIAL TO BE REMOVED BY MEANS OF AN APPROVED SAW TO FULL DEPTH AS SHOWN ON THE PLANS OR AS DIRECTED BY THE ENGINEER. THIS WORK SHALL BE INCLUDED IN THE COST OF THE ITEM BEING REMOVED. THE CONTRACTOR SHALL BE REQUIRED TO SAW VERTICAL CUTS SO AS TO FORM CLEAN VERTICAL JOINTS. SHOULD THE CONTRACTOR DEFACE ANY EDGE, A NEW SAWED JOINT SHALL BE PROVIDED AND ANY ADDITIONAL WORK, INCLUDING REMOVAL AND REPLACEMENT, SHALL BE DONE AT CONTRACTOR'S OWN EXPENSE.
- BINDER COURSE SHALL NOT BE PLACED ADJACENT TO CURB AND GUTTER UNTIL THE CURB AND GUTTER HAS BEEN PROPERLY CURED AND BACKFILLED TO THE SATISFACTION OF THE ENGINEER.
- HOT-MIX ASPHALT SURFACE COURSE SHALL NOT BE PLACED IN A STAGE UNTIL ALL EARTH EXCAVATION, TOPSOIL PLACEMENT, AND HOT-MIX ASPHALT BINDER COURSE WITHIN THE STAGE HAVE BEEN COMPLETED TO THE SATISFACTION OF THE ENGINEER.
- THE THICKNESSES OF HOT-MIX ASPHALT MIXTURES SHOWN ON THE PLANS ARE NOMINAL. DEVIATIONS MAY OCCUR DUE TO IRREGULARITIES IN THE BINDER OR BASE UPON WHICH THE HOT-MIX ASPHALT MATERIALS ARE PLACED.
- THE FINAL EDGE-OF-PAVEMENT SURFACE ELEVATION SHALL BE 1/4" ABOVE THE GUTTER AS SHOWN IN IDOT HIGHWAY STANDARD 606001.
- ANY MODIFICATIONS REQUIRED IN THE PLACEMENT OF COMBINATION CONCRETE CURB AND GUTTER WILL NOT BE PAID FOR SEPARATELY BUT SHALL BE INCLUDED IN THE COST OF "COMBINATION CONCRETE CURB AND GUTTER, TYPE AS SPECIFIED" AND "COMBINATION CONCRETE CURB AND GUTTER REMOVAL AND REPLACEMENT". THIS INCLUDES, BUT IS NOT LIMITED TO, TRANSITIONS IN THE CURB HEIGHT OR GUTTER WIDTH TO MATCH EXISTING CONDITIONS, TRANSITIONS AT DRAINAGE STRUCTURES, AND IRREGULARITIES AT EDGE-OF-PAVEMENT.
- ALL PROPOSED SIDEWALK AND SIDEWALK CURB RAMPS SHALL BE CONSTRUCTED TO THE SLOPES AND GRADES SHOWN IN IDOT HIGHWAY STANDARD 424001. THE PROPOSED SIDEWALK LIMITS SHOWN IN THE PLANS ARE ONLY APPROXIMATIONS BASED ON FIELD INVESTIGATIONS. THE ENGINEER WILL MAKE THE FINAL DETERMINATION OF THE SIDEWALK REPLACEMENT LIMITS IN THE FIELD. THE 6 INCH SIDE CURB ADJACENT TO SIDEWALK RAMPS WILL NOT BE PERMITTED. INSTEAD, THE LANDSCAPED AREAS NEAR THE SIDEWALK RAMPS WILL BE REGRADED TO MATCH THE PROPOSED EDGE-OF-SIDEWALK.

EXCAVATION

- EXCAVATION BENEATH PAVEMENT PATCHES AS SHOWN IN THE PLANS SHALL ONLY BE DONE IF THERE IS NO EXISTING AGGREGATE BASE COURSE OR IF THE EXISTING AGGREGATE BASE COURSE IS DETERMINED TO BE UNSTABLE. THE FINAL CONDITION OF THE MATERIAL WILL BE DETERMINED BY THE ENGINEER IN THE FIELD. THE EXCAVATION SHALL BE A MINIMUM OF 4" BENEATH THE PAVEMENT PATCH WHICH VOLUME, MEASURED IN CUBIC YARDS, WILL BE REPLACED WITH AGGREGATE BASE COURSE, TYPE B.

DRIVEWAY RECONSTRUCTION

- UNLESS DRIVEWAY RECONSTRUCTION IS INDICATED IN THE PLANS, THERE IS NO ANTICIPATION TO RECONSTRUCT ALL THE DRIVEWAY ENTRANCES. HOWEVER, IF A SITUATION ARISES WHERE DRIVEWAY RECONSTRUCTION IS NEEDED TO COMPLETE THE WORK SHOWN IN THE PLANS, PRIOR APPROVAL SHALL BE OBTAINED FROM THE ENGINEER BEFORE STARTING WORK. THE ENGINEER SHALL MAKE THE FINAL DECISION ON THE LIMITS OF DRIVEWAY RECONSTRUCTION. ANY DRIVEWAYS THAT WERE DAMAGED WITHOUT APPROVAL FOR RECONSTRUCTION FROM THE ENGINEER OR DUE TO CONTRACTOR'S NEGLIGENCE SHALL BE REPLACED IN KIND AT CONTRACTOR'S OWN EXPENSE.
- IDOT DISTRICT ONE DETAIL BD-24 "CURB OR CURB AND GUTTER REMOVAL AND REPLACEMENT" SHOWS A MAXIMUM DRIVEWAY RESTORATION WIDTH OF 18" BEHIND THE BACK-OF-CURB. THIS DRIVEWAY RESTORATION WIDTH WILL NOT BE ALLOWED IF PAVEMENT PATCHING IS COMPLETED NEXT TO CURB AND GUTTER REPLACEMENT. THE CONTRACTOR IS EXPECTED TO CAREFULLY REMOVE THE CURB AND GUTTER WITHOUT DAMAGING THE DRIVEWAY APRON. ANY DAMAGE DONE TO DRIVEWAY ENTRANCE BEHIND THE BACK-OF-CURB WILL BE REPLACED IN KIND AT CONTRACTOR'S OWN EXPENSE.
- WHEN PERMITTED BY THE ENGINEER, DRIVEWAY RECONSTRUCTION SHALL BE CONSTRUCTED AS FOLLOWS:
 RESIDENTIAL HMA DRIVEWAY RECONSTRUCTION:
 -HOT-MIX ASPHALT DRIVEWAY PAVEMENT, 4"
 -AGGREGATE BASE COURSE, TYPE B 6"
 RESIDENTIAL PCC DRIVEWAY RECONSTRUCTION:
 -PORTLAND CEMENT CONCRETE DRIVEWAY PAVEMENT, 6 INCH
 -AGGREGATE BASE COURSE, TYPE B 4"

SEWER

- THE COST OF MAKING SEWER CONNECTIONS TO EXISTING OR PROPOSED SEWER OR DRAINAGE/SANITARY STRUCTURES SHALL BE INCLUDED IN THE COST OF THE SEWER OR STRUCTURE BEING CONSTRUCTED.
- UNLESS OTHERWISE NOTED ON THE PLANS, THE EXISTING DRAINAGE FACILITIES SHALL REMAIN IN USE DURING THE PERIOD OF CONSTRUCTION. LOCATIONS OF EXISTING DRAINAGE STRUCTURES AND SEWERS AS SHOWN ON THE PLANS ARE APPROXIMATE. PRIOR TO COMMENCING WORK THE CONTRACTOR, AT HIS OWN EXPENSE, SHALL DETERMINE THE EXACT LOCATIONS OF EXISTING STRUCTURES WHICH ARE WITHIN THE PROPOSED CONSTRUCTION LIMITS. DURING CONSTRUCTION, IF THE CONTRACTOR ENCOUNTERS OR OTHERWISE BECOMES AWARE OF ANY SEWERS, UNDERDRAINS OR FIELD DRAINS WITHIN THE RIGHT-OF-WAY OTHER THAN THOSE SHOWN ON THE PLANS, HE SHALL SO INFORM THE ENGINEER, WHO SHALL DIRECT THE WORK NECESSARY TO MAINTAIN OR REPLACE THE FACILITIES IN SERVICE AND TO PROTECT THEM FROM DAMAGE DURING CONSTRUCTION IF MAINTAINED. EXISTING FACILITIES TO BE MAINTAINED THAT ARE DAMAGED BECAUSE OF THE NON-COMPLIANCE WITH THIS PROVISION SHALL BE REPLACED AT THE CONTRACTOR'S OWN EXPENSE. SHOULD THE ENGINEER HAVE DIRECTED THE REPLACEMENT OF A FACILITY, THE NECESSARY WORK AND PAYMENT SHALL BE IN ACCORDANCE WITH SECTIONS 550 AND 601, AND ARTICLE 104.02 OF THE STANDARD SPECIFICATIONS.
- WHEN EXISTING DRAINAGE FACILITIES ARE DISTURBED, THE CONTRACTOR SHALL PROVIDE AND MAINTAIN TEMPORARY OUTLETS AND CONNECTIONS FOR ALL PRIVATE OR PUBLIC DRAINS, SEWERS OR CATCH BASINS. THE CONTRACTOR SHALL PROVIDE FACILITIES TO TAKE IN ALL STORM WATER WHICH WILL BE RECEIVED BY THESE DRAINS AND SEWERS AND DISCHARGE THE SAME. HE SHALL PROVIDE AND MAINTAIN AN EFFICIENT PUMPING PLANT, IF NECESSARY, AND A TEMPORARY OUTLET. HE SHALL BE PREPARED AT ALL TIMES TO DISPOSE OF THE WATER RECEIVED FROM TEMPORARY CONNECTIONS UNTIL SUCH TIME AS THE PERMANENT CONNECTIONS WITH SEWER ARE BUILT AND IN SERVICE. THIS WORK WILL NOT BE PAID FOR SEPARATELY, BUT SHALL BE INCLUDED IN THE UNIT BID PRICES OF THE CONTRACT.
- ALL ABANDONED PIPE AND STRUCTURE INVERTS SHALL BE PLUGGED WITH BRICK AND MORTAR TO THE SATISFACTION OF THE ENGINEER. THIS WORK SHALL BE INCLUDED IN THE COST OF ITEMS BEING REMOVED.
- TOP OF FRAME ("RIM") ELEVATIONS GIVEN ON THE PLANS ARE ONLY TO ASSIST THE CONTRACTOR IN DETERMINING THE APPROXIMATE OVERALL HEIGHT OF EACH STRUCTURE. FRAMES ON ALL NEW STRUCTURES SHALL BE ADJUSTED TO THE FINAL ELEVATIONS OF THE AREAS IN WHICH THEY ARE LOCATED, AS PART OF THE STRUCTURE COST. PIPE INVERTS AND DIRECTIONS NOTED IN THE PLANS ARE NOT ABSOLUTE AND MAY REQUIRE SLIGHT ADJUSTMENT IN THE FIELD AS DIRECTED BY THE ENGINEER.
- DRAINAGE STRUCTURE FLAT-TOPS AND CONES SHALL BE TURNED SO THAT THE FRAMES ARE CLOSEST TO THE CENTERLINE OF THE ROAD. ALL DRAINAGE STRUCTURES IN THE CURB LINE SHALL BE ROTATED AWAY FROM PAVEMENT AND INTO THE PARKWAY UNLESS OTHERWISE NOTED IN THE PLANS. ALL FLAT-TOPS AND CONES ARE ASSUMED TO BE ECCENTRIC.
- ALL SEWER AND WATER SERVICES CROSSED BY NEW STORM SEWERS SHALL BE PROPERLY LOCATED AND PROTECTED DURING CONSTRUCTION. ANY DAMAGE TO SAID SERVICES NOT CONSIDERED TO BE IN CONFLICT WITH THE PROPOSED STORM SEWER SHALL BE REPAIRED BY THE CONTRACTOR AT HIS OWN EXPENSE.
- THE PAY ITEMS "ADJUSTING SANITARY SEWERS, 8-INCH DIAMETER OR LESS" AND "ADJUSTING SANITARY SEWERS, OVER 8-INCH DIAMETER" SHALL ONLY BE USED WHEN APPROVED BY THE ENGINEER. THESE ITEMS SHALL NOT BE USED TO ADJUST PROPOSED SANITARY SERVICES, BUT SHALL BE USED ONLY TO ADJUST EXISTING SANITARY SERVICES THAT ARE IN CONFLICT WITH THE PROPOSED UTILITY INSTALLATIONS.

INDEX OF SHEETS

SHEET NO.	DESCRIPTION
1	COVER SHEET
2	GENERAL NOTES AND INDEX OF SHEETS
3	GENERAL NOTES AND STANDARD DRAWINGS
4 - 6	SUMMARY OF QUANTITIES
7 - 10	TYPICAL SECTIONS
11 - 12	EARTHWORK SCHEDULES
13 - 17	ALIGNMENT, TIES AND BENCHMARKS
18 - 31	ROADWAY REMOVAL, PROPOSED PLAN AND PROFILE
32 - 39	PROPOSED ROADWAY PLAN
40	MAINTENANCE OF TRAFFIC - GENERAL NOTES
41	MAINTENANCE OF TRAFFIC - ROAD CLOSURE DETAILS
42 - 50	PAVEMENT MARKING, SIGNING AND LANDSCAPING PLAN
51 - 62	CONSTRUCTION DETAILS

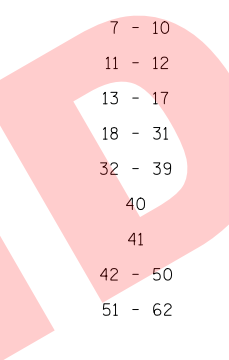

WATER

- THE PAY ITEM "ADJUSTING WATER SERVICE LINES" SHALL ONLY BE USED WHEN APPROVED BY THE ENGINEER. THIS ITEM WILL NOT BE USED TO ADJUST PROPOSED WATER SERVICES, BUT SHALL BE USED ONLY TO ADJUST EXISTING WATER SERVICE LINES THAT ARE IN CONFLICT WITH THE PROPOSED UTILITY INSTALLATIONS.
- BUFFALO BOXES (B-BOXES) SHALL BE ADJUSTED TO THE FINAL GRADE AND WILL BE KEYABLE AFTER THE COMPLETION OF FINAL LANDSCAPING OR FINAL PAVING (IN AREAS WHERE B-BOXES ARE LOCATED IN PAVED SURFACES). THE ADJUSTMENT TO THE FINAL GRADE WILL NOT BE PAID FOR SEPARATELY BUT SHALL BE INCLUDED IN THE COST OF THE PROPOSED ITEMS BEING INSTALLED.

MAILBOXES

- THE CONTRACTOR SHALL PROTECT AND RELOCATE ALL EXISTING MAILBOXES WHICH INTERFERE WITH THE WORK IN ACCORDANCE WITH THE APPLICABLE PORTIONS OF ARTICLE 107.20 OF THE STANDARD SPECIFICATIONS. THIS WORK WILL NOT BE PAID FOR SEPARATELY BUT SHALL BE CONSIDERED AS INCLUDED IN THE UNIT BID PRICES OF THE CONTRACT, AND ADDITIONAL COMPENSATION WILL NOT BE ALLOWED.

PLOT DRIVER = ...\\njb\dms\0314\con_pdf.plt
 PEN TABLE = ...\\njb\cui\dot_general.tbl
 FILE NAME = ...3015-shr-geno.tbl.dgn



USER NAME = mjp	DESIGNED - MJP	REVISED -
	DRAWN - MJP	REVISED -
PLOT SCALE = 1:8000' / 1"	CHECKED - DNM	REVISED -
PLOT DATE = 4/14/2016	DATE - 04/15/16	REVISED -

VILLAGE OF VILLA PARK

**2016 STREET IMPROVEMENTS
GENERAL NOTES AND INDEX OF SHEETS**

SCALE: N.T.S. SHEET OF SHEETS STA. TO STA.

F.A. RTE.	SECTION	COUNTY	TOTAL SHEETS	SHEET NO.
		DUPAGE	62	2
CONTRACT NO.				
ILLINOIS FED. AID PROJECT				

UTILITIES

1. THE CONTRACTOR SHALL COORDINATE CONSTRUCTION ACTIVITIES WITH UTILITY COMPANIES. THE LOCATION OF PUBLIC OR PRIVATE UTILITIES SHOWN ON THE PLANS ARE APPROXIMATE AND THE ENGINEER DOES NOT GUARANTEE THEIR ACCURACY. THE CONTRACTOR WILL BE REQUIRED TO ASCERTAIN THE EXACT LOCATION OF SUCH UTILITIES AND EXERCISE CARE DURING HIS CONSTRUCTION OPERATIONS SO AS NOT TO DAMAGE THEM IN ACCORDANCE WITH THE SPECIAL PROVISIONS AND ARTICLE 107.31 OF THE "STANDARD SPECIFICATIONS." THE CONTRACTOR SHALL BE RESPONSIBLE FOR CONTACTING THE OWNERS OF ALL EXISTING UTILITIES SO THAT THEIR FACILITIES MAY BE LOCATED AND ADJUSTED OR MOVED, IF NECESSARY, PRIOR TO THE START OF THE CONSTRUCTION OPERATIONS.
2. THE CONTRACTOR SHALL BE RESPONSIBLE FOR THE PROTECTION OF ALL ABOVE AND BELOW GROUND UTILITIES EVEN THOUGH THEY MAY NOT BE SHOWN ON THE PLANS. ANY UTILITY THAT IS DAMAGED DURING CONSTRUCTION SHALL BE REPAIRED OR REPLACED TO THE SATISFACTION OF THE ENGINEER OR THE UTILITY OWNER. THIS WORK SHALL BE AT THE CONTRACTOR'S EXPENSE. THE CONTRACTOR SHALL NOTIFY ALL UTILITY OWNERS OF HIS CONSTRUCTION SCHEDULE AND SHALL COORDINATE CONSTRUCTION OPERATIONS WITH THE UTILITY OWNERS SO THAT RELOCATION OF UTILITY LINES AND STRUCTURES MAY PROCEED IN AN ORDERLY MANNER. NOTIFICATION SHALL BE IN WRITING, WITH COPIES TRANSMITTED TO THE ENGINEER.
3. ANY EXISTING OR PROPOSED UTILITY DAMAGED BY THE CONTRACTOR DURING CONSTRUCTION SHALL BE REPLACED BY THE CONTRACTOR TO THE SATISFACTION OF THE ENGINEER AT NO COST TO THE VILLAGE.
4. THE CONTRACTOR SHALL RECEIVE NO ADDITIONAL COMPENSATION FOR CONSTRUCTION STAGING NECESSARY TO ACCOMMODATE UTILITY RELOCATION OR ADJUSTMENT AND/OR FOR DELAYS CAUSED BY UTILITY RELOCATION OR ADJUSTMENT.
5. THE CONTRACTOR SHALL FURNISH ALL LABOR, EQUIPMENT AND MATERIAL NECESSARY FOR DEWATERING TRENCH EXCAVATIONS AS WELL AS SHORING TRENCH WALLS DURING UTILITY OPERATIONS. COMPLIANCE WITH THE ABOVE WILL NOT BE PAID FOR SEPARATELY, BUT SHALL BE INCLUDED IN THE UNIT BID PRICES OF THE CONTRACT.

















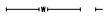
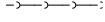





SOIL EROSION AND SEDIMENT CONTROL

1. ALL VEGETATIVE AND STRUCTURAL EROSION CONTROL PRACTICES SHALL BE CONSTRUCTED AND MAINTAINED IN ACCORDANCE WITH THE MINIMUM STANDARDS AND SPECIFICATIONS OF THE "ILLINOIS URBAN MANUAL (JUNE, 2013 EDITION)".
2. SOIL DISTURBANCE SHALL BE CONDUCTED IN SUCH A MANNER AS TO MINIMIZE EROSION. SOIL STABILIZATION MEASURES SHALL CONSIDER THE TIME OF YEAR, SITE CONDITIONS AND THE USE OF TEMPORARY OR PERMANENT MEASURES.
3. ALL EROSION CONTROL MEASURES SHALL BE IN PLACE BEFORE ANY WORK BEGINS.
4. THE CONTRACTOR SHALL INSPECT ALL EROSION CONTROL MEASURES WEEKLY AND AFTER EACH 1/2" RUNOFF-PRODUCING RAINFALL EVENT. ANY NECESSARY REPAIRS OR CLEANUP TO MAINTAIN THE EFFECTIVENESS OF SAID MEASURES SHALL BE MADE IMMEDIATELY. ALL MAINTENANCE OF EROSION CONTROL ITEMS IS INCLUDED IN THE COST OF THE ITEM AND NO ADDITIONAL COMPENSATION SHALL BE GIVEN TO THE CONTRACTOR.
5. ALL STORM SEWER FACILITIES THAT ARE OR WILL BE FUNCTIONING DURING CONSTRUCTION SHALL BE PROTECTED, FILTERED OR OTHERWISE TREATED TO REMOVE SEDIMENT. MUD AND SEDIMENT DEPOSITS SHALL BE REMOVED FROM THE ROADWAY AT THE END OF EACH WORK DAY BY SHOVELING AND/OR SWEEPING.
6. INLET FILTERS SHALL BE PLACED ON ALL CATCH BASINS, INLETS, AND MANHOLES WITH OPEN GRATES IN THE PROJECT AREA.
7. ALL SLOPES SHALL BE COVERED WITH SOD OR SEED & EROSION CONTROL BLANKET AS SOON AS GRADING AND PLACEMENT OF TOPSOIL HAS BEEN COMPLETED.
8. THE EROSION CONTROL MEASURES INDICATED ON THE PLANS ARE THE MINIMUM REQUIREMENTS. ADDITIONAL MEASURES MAY BE REQUIRED AS DIRECTED BY THE ENGINEER.

TREE PROTECTION & LANDSCAPING

1. THE ENGINEER WILL DETERMINE AREAS WHERE TEMPORARY FENCE MAY BE NEEDED TO PROTECT TREES IN CLOSE PROXIMITY TO CONSTRUCTION OPERATIONS. TEMPORARY FENCE SHALL BE PLACED AROUND THE TREE AT DRIP LINE. NEW TEMPORARY FENCE OR THE RELOCATION OF TEMPORARY FENCE FROM ONE LOCATION TO ANOTHER LOCATION SHALL BE PAID FOR AS "TEMPORARY FENCE". THE TEMPORARY FENCE SHALL NOT BE RELOCATED UNTIL ALL WORK IS COMPLETED IN THAT AREA.
2. EXCAVATION NEAR TREES MAY REQUIRE TREE ROOT PRUNING AS DIRECTED BY THE ENGINEER.
3. THE CONTRACTOR SHALL ADHERE TO LIMITS OF RESTORATION SHOWN IN THE PLANS. AREAS OUTSIDE THESE LIMITS THAT ARE DAMAGED OR DISTURBED BY THE CONTRACTOR SHALL BE RESTORED AT CONTRACTOR'S OWN EXPENSE, AND ADDITIONAL COMPENSATION WILL NOT BE ALLOWED.
4. THE NOMINAL DEPTH OF TOPSOIL TO BE FURNISHED AND PLACED IS 4". VARIATIONS IN DEPTH MAY EXIST THROUGHOUT THE PROJECT AREA WHICH MAY REQUIRE A LARGER OR SMALLER DEPTH OF TOPSOIL DEPENDING ON THE FINAL GRADING CONDITIONS. WHERE APPLICABLE, THE CONTRACTOR SHALL GRADE THE DISTURBED PARKWAY SUCH THAT IT POSITIVELY DRAINS TOWARDS THE ROADWAY. THIS WORK, INCLUDING ANY VARIATIONS IN TOPSOIL DEPTH, WILL BE MEASURED FOR PAYMENT IN SQUARE YARDS AND PAID FOR AS: TOPSOIL FURNISH AND PLACE, 4".

ADDITIONAL SYMBOLS, ABBREVIATIONS AND PATTERNS

-  EXISTING VALVE VAULT
-  EXISTING VALVE AND VALVE BOX
-  EXISTING FIRE HYDRANT
-  EXISTING DOMESTIC WATER SERVICE BOX
-  EXISTING SANITARY SEWER CLEAN OUT
-  EXISTING WATER MAIN
-  EXISTING WATER SERVICE
-  EXISTING SANITARY SEWER
-  EXISTING COMBINED SEWER
-  EXISTING STORM SEWER
-  HOT-MIX ASPHALT RESURFACING: HOT-MIX ASPHALT SURFACE COURSE, MIX "D", N50 (PROPOSED PLAN)
-  HOT-MIX ASPHALT RESURFACING: HOT-MIX ASPHALT SURFACE REMOVAL, VARIABLE DEPTH (REMOVAL PLAN)
-  HOT-MIX ASPHALT RESURFACING: PORTLAND CEMENT CONCRETE SURFACE REMOVAL 2" (REMOVAL PLAN)
-  COMBINATION CONCRETE CURB AND GUTTER REMOVAL AND REPLACEMENT
-  CLASS C PATCHES (DEPTH AS NOTED)
-  CLASS D PATCHES (DEPTH AS NOTED)
-  HOT-MIX ASPHALT SURFACE REMOVAL - BUTT JOINT
-  PAVEMENT REMOVAL
-  DRIVEWAY PAVEMENT REMOVAL
-  SIDEWALK REMOVAL
-  COMBINATION CURB AND GUTTER REMOVAL
-  SEWER REMOVAL
-  SINGLE ITEM REMOVAL

CLEARING

1. CONTRACTOR SHALL PAY SPECIAL ATTENTION TO ARTICLE 201.01(a) OF THE STANDARD SPECIFICATIONS. REMOVAL OF ALL OBSTRUCTIONS IN THE RIGHT-OF-WAY, THAT ARE NOT INCLUDED IN A SPECIFIC REMOVAL ITEM, SHALL BE CONSIDERED CLEARING AND INCLUDED IN THE COST OF THE CONTRACT. THIS SHALL INCLUDE, BUT NOT LIMITED TO, FENCES, WALLS, FOUNDATIONS, BUILDINGS, WOODEN POWER POLES, WOODEN PLANTERS, GATES, AND ALL VEGETATION, TREES, SHRUBS, ETC. LESS THAN 6" IN DIAMETER.

SIGNING & STRIPING

1. ALL EXISTING TRAFFIC SIGNS WHICH INTERFERE WITH THE CONTRACTOR'S WORK SHALL BE REMOVED PER ARTICLE 107.25. A RECORD SHALL BE MADE OF THEIR CONDITION, AND THEY SHALL BE SAFELY STORED AND SAFEGUARDED BY THE CONTRACTOR UNTIL THE ENGINEER DETERMINES THAT THEY BE REINSTALLED IN THE PERMANENT LOCATIONS. "STOP" SIGNS SHALL BE IMMEDIATELY REINSTALLED AFTER WORK IS COMPLETED IN AREA TO MAINTAIN ROADWAY SAFETY CONDITIONS. ANY SIGN WHICH IS DAMAGED DURING THE TIME IT IS STORED SHALL BE REPAIRED OR REPLACED IN KIND AT CONTRACTOR'S OWN EXPENSE PRIOR TO PERMANENT REINSTALLATION.
2. ALL EXISTING SIGNS AND POSTS REMOVED AND NOT REINSTALLED WILL BE EVALUATED BY THE ENGINEER IN THE FIELD. THE ENGINEER WILL DETERMINE WHICH ITEMS WILL BE RETURNED TO THE VILLAGE AND WHICH ITEMS WILL BE DISPOSED. THE DELIVERY AND DISPOSAL OF THESE ITEMS WILL BE INCLUDED IN THE COST OF "REMOVE SIGN PANEL ASSEMBLY, TYPE AS NOTED". SIGNS AND POSTS DEEMED BY THE ENGINEER TO BE RETURNED SHALL BE DELIVERED TO:

VILLAGE OF VILLA PARK
PUBLIC WORKS DEPARTMENT YARD
11 WEST HOME AVENUE
VILLA PARK, IL 60181

STATE STANDARDS

STANDARD NO.	DESCRIPTION
000001-06	STANDARD SYMBOLS, ABBREVIATIONS AND PATTERNS
280001-07	TEMPORARY EROSION CONTROL SYSTEMS
424001-08	PERPENDICULAR CURB RAMPS FOR SIDEWALKS
442201-03	CLASS C AND D PATCHES
602001-02	CATCH BASIN TYPE A
602301-04	INLET - TYPE A
602401-03	MANHOLE TYPE A
602601-04	PRECAST REINFORCED CONCRETE FLAT SLAB TOP
604001-04	FRAME AND LIDS TYPE 1
604051-04	FRAME & GRATE TYPE 11
606001-06	CONCRETE CURB TYPE B AND COMBINATION CONCRETE CURB AND GUTTER
701011-04	OFF-RD MOVING OPERATIONS, 2L, 2W, DAY ONLY
701311-03	LANE CLOSURE, 2L, 2W, MOVING OPERATIONS - DAY ONLY
701501-06	URBAN LANE CLOSURE, 2L, 2W, UNDIVIDED
701701-10	URBAN LANE CLOSURE, MULTILANE INTERSECTION
701801-06	SIDEWALK, CORNER OR CROSSWALK CLOSURE
701901-05	TRAFFIC CONTROL DEVICES
720001-01	SIGN PANEL MOUNTING DETAILS
720006-04	SIGN PANEL ERECTION DETAILS
728001-01	TELESCOPING STEEL SIGN SUPPORT
780001-05	TYPICAL PAVEMENT MARKINGS

NOTE: THE CONSTRUCTION DETAILS SHALL SUPERCEDE IDOT STANDARD DRAWINGS.

EPOXY COATING ON REINFORCEMENT

1. FOR WORK OUTSIDE THE LIMITS OF BRIDGE APPROACH PAVEMENT, ALL REFERENCES IN THE HIGHWAY STANDARDS AND STANDARD SPECIFICATIONS FOR REINFORCEMENT, DOWEL BARS AND TIE BARS IN PAVEMENT, SHOULDERS, CURB, GUTTER, COMBINATION CURB AND GUTTER AND MEDIAN, AND CHAIR SUPPORTS FOR CRC PAVEMENT, SHALL BE EPOXY COATED, UNLESS NOTED ON THE PLANS.

MISCELLANEOUS

1. DIMENSIONS: IT SHALL BE THE CONTRACTOR'S RESPONSIBILITY TO VERIFY ALL DIMENSIONS AND CONDITIONS EXISTING IN THE FIELD PRIOR TO ORDERING MATERIALS AND BEGINNING CONSTRUCTION.
2. UNLESS OTHERWISE AUTHORIZED BY THE ENGINEER, ALL EXISTING ACCESS POINTS SHALL BE MAINTAINED AT ALL TIMES BY THE CONTRACTOR.

PLOT DRIVER = ...\\n:\p\dms\0314\ven...pdf...
PEN TABLE = ...\\p\tbl\con\idot...
FILE NAME = ...3015-sht-gennote02.dgn



USER NAME = mjp	DESIGNED - MJP	REVISED -
	DRAWN - MJP	REVISED -
PLOT SCALE = 1:8000' / 1"	CHECKED - DNM	REVISED -
PLOT DATE = 4/14/2016	DATE - 04/15/16	REVISED -

VILLAGE OF VILLA PARK

**2016 STREET IMPROVEMENTS
GENERAL NOTES AND STATE STANDARDS**

SCALE: N.T.S. SHEET OF SHEETS STA. TO STA.

F.A. RTE.	SECTION	COUNTY	TOTAL SHEETS	SHEET NO.
			62	3
CONTRACT NO.				
ILLINOIS FED. AID PROJECT				

SUMMARY OF QUANTITIES

SUMMARY OF 2016 STREET IMPROVEMENTS					REFERENDUM STREETS							NON-REFERENDUM STREETS				
IDOT CODE NO.	ITEM NO.	ITEM DESCRIPTION	UNIT	TOTAL QUANTITY	HARRISON STREET (STA. 10+38 TO STA. 14+25)	HARRISON STREET (STA. 19+50 TO STA. 23+05)	ORCHARD HILL COURT (STA. 0+00 TO STA. 1+74.4)	LESLIE LANE (STA. 20+32.5 TO STA. 27+50)	MONROE STREET (STA. 30+18.6 TO STA. 56+63)	SUMMIT AVENUE (STA. 55+90 TO STA. 98+10)	HOME AVENUE (STA. 40+10 TO STA. 52+65)	HARRISON STREET (STA. 14+25 TO STA. 19+50)	LESLIE LANE (STA. 27+50 TO STA. 41+62)	WILDFIRE DRIVE (STA. 60+41 TO STA. 72+85)	PRINCETON AVENUE (STA. 84+52 TO STA. 87+13.5)	ARDMORE AVENUE (STA. 166+24 TO STA. 168+71)
20101000	1	TEMPORARY FENCE	FOOT	2,160	60	20	160	0	1,520	100	180	60	60	0	0	0
20101200	2	TREE ROOT PRUNING	EACH	52	1	0	5	0	44	0	0	2	0	0	0	0
20200100	3	EARTH EXCAVATION	CU YD	942	5	41	58	0	537	40	93	86	16	0	66	0
20201200	4	REMOVAL AND DISPOSAL OF UNSUITABLE MATERIAL	CU YD	1,396	15	9	38	57	235	162	755	27	55	24	19	0
20800150	5	TRENCH BACKFILL	CU YD	74	0	5	0	0	35	0	34	0	0	0	0	0
21101615	6	TOPSOIL FURNISH AND PLACE, 4"	SQ YD	3,334	84	61	315	25	1,826	368	239	83	137	0	196	0
25000400	7	NITROGEN FERTILIZER NUTRIENT	POUND	46	2	1	4	1	23	5	3	2	2	0	3	0
25000500	8	PHOSPHORUS FERTILIZER NUTRIENT	POUND	46	2	1	4	1	23	5	3	2	2	0	3	0
25000600	9	POTASSIUM FERTILIZER NUTRIENT	POUND	46	2	1	4	1	23	5	3	2	2	0	3	0
25200100	10	SODDING	SQ YD	3,334	84	61	315	25	1,826	368	239	83	137	0	196	0
25200200	11	SUPPLEMENTAL WATERING	UNIT	35	1	1	3	1	17	4	3	1	2	0	2	0
28000250	12	TEMPORARY EROSION CONTROL SEEDING	POUND	73	2	2	7	1	38	8	5	2	3	0	5	0
28000400	13	PERIMETER EROSION BARRIER	FOOT	61	0	0	0	0	0	0	0	0	0	0	61	0
28000510	14	INLET FILTERS	EACH	109	0	4	1	12	14	42	15	1	18	0	2	0
35101500	15	AGGREGATE BASE COURSE, TYPE B	CU YD	422	13	6	21	58	86	132	22	17	43	24	0	0
35101600	16	AGGREGATE BASE COURSE, TYPE B 4"	SQ YD	3,546	40	28	248	31	1,926	395	654	64	143	0	17	0
35101800	17	AGGREGATE BASE COURSE, TYPE B 6"	SQ YD	636	80	57	49	33	100	86	109	21	28	0	73	0
35102000	18	AGGREGATE BASE COURSE, TYPE B 8"	SQ YD	2,594	0	180	0	0	0	0	2,045	369	0	0	0	0
35800100	19	PREPARATION OF BASE	SQ YD	507	0	0	0	0	0	0	0	0	0	0	507	0
35800200	20	AGGREGATE BASE REPAIR	TON	46	0	0	0	0	0	0	0	0	0	0	46	0
40201000	21	AGGREGATE FOR TEMPORARY ACCESS	TON	371	0	16	40	0	231	0	82	0	0	0	2	0
40600290	22	BITUMINOUS MATERIALS (TACK COAT)	POUND	22,042	785	639	614	1,292	5,259	8,195	1,483	954	2,647	54	120	0
40600400	23	MIXTURE FOR CRACKS, JOINTS, AND FLANGWAYS	TON	19	1	1	1	2	4	6	1	1	2	0	0	0
40600625	24	LEVELING BINDER (MACHINE METHOD), N50	TON	1,333	49	38	39	81	328	510	68	55	165	0	0	0
40600982	25	HOT-MIX ASPHALT SURFACE REMOVAL - BUTT JOINT	SQ YD	486	19	19	0	17	144	183	56	0	48	0	0	0
40603080	26	HOT-MIX ASPHALT BINDER COURSE, IL-19.0, N50	TON	597	0	41	0	0	0	0	398	83	0	0	75	0
40603335	27	HOT-MIX ASPHALT SURFACE COURSE, MIX "D", N50	TON	2,992	98	95	77	161	655	1,020	334	150	330	27	45	0
42001300	28	PROTECTIVE COAT	SQ YD	3,092	50	33	137	6	1,651	386	633	39	140	0	17	0
42300200	29	PORTLAND CEMENT CONCRETE DRIVEWAY PAVEMENT, 6 INCH	SQ YD	724	12	0	81	31	434	91	0	21	37	0	17	0
42300400	30	PORTLAND CEMENT CONCRETE DRIVEWAY PAVEMENT, 8 INCH	SQ YD	75	0	0	0	0	0	0	75	0	0	0	0	0
42400200	31	PORTLAND CEMENT CONCRETE SIDEWALK 5 INCH	SQ FT	7,740	246	0	275	0	2,577	2,738	949	0	955	0	0	0
42400300	32	PORTLAND CEMENT CONCRETE SIDEWALK 6 INCH	SQ FT	268	0	0	0	0	268	0	0	0	0	0	0	0
42400410	33	PORTLAND CEMENT CONCRETE SIDEWALK 8 INCH	SQ FT	307	0	0	0	0	0	0	307	0	0	0	0	0
42400800	34	DETECTABLE WARNINGS	SQ FT	787	21	0	33	0	202	309	120	0	102	0	0	0
44000100	35	PAVEMENT REMOVAL	SQ YD	2,870	0	179	15	0	0	0	1,788	367	0	0	521	0
44000200	36	DRIVEWAY PAVEMENT REMOVAL	SQ YD	1,268	0	11	119	0	692	37	349	0	0	0	60	0

PLOT DRIVER = ...
PEN TABLE = ...
FILE NAME = ...



USER NAME = mjp	DESIGNED - MJP	REVISED -
	DRAWN - MJP	REVISED -
PLOT SCALE = 1:8000' / 1"	CHECKED - DNM	REVISED -
PLOT DATE = 4/14/2016	DATE - 04/15/16	REVISED -

VILLAGE OF VILLA PARK

**2016 STREET IMPROVEMENTS
SUMMARY OF QUANTITIES**

SCALE: N.T.S. SHEET OF SHEETS STA. TO STA.

F.A. RTE.	SECTION	COUNTY	TOTAL SHEETS	SHEET NO.
		DUPAGE	62	4
CONTRACT NO.				
ILLINOIS FED. AID PROJECT				

SUMMARY OF QUANTITIES

SUMMARY OF 2016 STREET IMPROVEMENTS					REFERENDUM STREETS							NON-REFERENDUM STREETS				
IDOT CODE NO.	ITEM NO.	ITEM DESCRIPTION	UNIT	TOTAL QUANTITY	HARRISON STREET (STA. 10+38 TO STA. 14+25)	HARRISON STREET (STA. 19+50 TO STA. 23+05)	ORCHARD HILL COURT (STA. 0+00 TO STA. 1+74.4)	LESLIE LANE (STA. 20+32.5 TO STA. 27+50)	MONROE STREET (STA. 30+18.6 TO STA. 56+63)	SUMMIT AVENUE (STA. 55+90 TO STA. 98+10)	HOME AVENUE (STA. 40+10 TO STA. 52+65)	HARRISON STREET (STA. 14+25 TO STA. 19+50)	LESLIE LANE (STA. 27+50 TO STA. 41+62)	WILDFIRE DRIVE (STA. 60+41 TO STA. 72+85)	PRINCETON AVENUE (STA. 84+52 TO STA. 87+13.5)	ARDMORE AVENUE (STA. 166+24 TO STA. 168+71)
44000500	37	COMBINATION CURB AND GUTTER REMOVAL	FOOT	8,273	0	120	517	0	5,081	0	2,368	187	0	0	0	0
44000600	38	SIDEWALK REMOVAL	SQ FT	7,926	293	0	371	0	2,374	2,719	1,186	0	983	0	0	0
	39	CLASS C PATCHES, 6 INCH	SQ YD	1,839	30	0	186	0	1,558	0	0	65	0	0	0	0
	40	CLASS D PATCHES, 6 INCH	SQ YD	3,168	145	89	0	574	0	1,303	260	193	392	212	0	0
48101500	41	AGGREGATE SHOULDERS, TYPE B 6"	SQ YD	129	0	0	0	0	0	0	35	0	0	0	94	0
550A0040	42	STORM SEWERS, CLASS A, TYPE 1 10"	FOOT	34	0	34	0	0	0	0	0	0	0	0	0	0
550B0040	43	STORM SEWERS, CLASS B, TYPE 1 10"	FOOT	28	0	0	0	0	0	0	28	0	0	0	0	0
550B0330	44	STORM SEWERS, CLASS B, TYPE 2 10"	FOOT	133	0	0	0	0	0	0	133	0	0	0	0	0
56300100	45	ADJUSTING SANITARY SEWERS, 8-INCH DIAMETER OR LESS	FOOT	64	0	0	0	0	32	0	32	0	0	0	0	0
56300200	46	ADJUSTING SANITARY SEWERS, OVER 8-INCH DIAMETER	FOOT	16	0	0	0	0	0	0	16	0	0	0	0	0
56300300	47	ADJUSTING WATER SERVICE LINES	FOOT	48	0	0	0	0	0	0	48	0	0	0	0	0
60201105	48	CATCH BASINS, TYPE A, 4' -DIAMETER, TYPE 11 FRAME AND GRATE	EACH	2	0	0	0	0	2	0	0	0	0	0	0	0
60207905	49	CATCH BASINS, TYPE C, TYPE 11 FRAME AND GRATE	EACH	6	0	1	0	0	0	0	5	0	0	0	0	0
60218400	50	MANHOLES, TYPE A, 4' -DIAMETER, TYPE 1 FRAME, CLOSED LID	EACH	4	0	0	0	0	1	0	3	0	0	0	0	0
60236800	51	INLETS, TYPE A, TYPE 11 FRAME AND GRATE	EACH	3	0	1	0	0	2	0	0	0	0	0	0	0
60404800	52	FRAMES AND GRATES, TYPE 11	EACH	14	0	0	0	0	8	0	5	1	0	0	0	0
	53	FRAMES AND LIDS, TYPE 1	EACH	12	0	0	0	0	5	6	0	0	1	0	0	0
60603800	54	COMBINATION CONCRETE CURB AND GUTTER, TYPE B-6. 12	FOOT	8,270	0	120	517	0	5,080	0	2,366	187	0	0	0	0
66900200	55	NON-SPECIAL WASTE DISPOSAL	CU YD	100	0	0	0	0	0	0	100	0	0	0	0	0
72400500	56	RELOCATE SIGN PANEL ASSEMBLY - TYPE A	EACH	1	0	0	0	0	0	0	1	0	0	0	0	0
72800100	57	TELESCOPING STEEL SIGN SUPPORT	FOOT	14	0	0	0	0	0	0	14	0	0	0	0	0
78000100	58	THERMOPLASTIC PAVEMENT MARKING - LETTERS AND SYMBOLS	SQ FT	37	0	0	0	0	0	0	0	0	0	0	0	37
78000200	59	THERMOPLASTIC PAVEMENT MARKING - LINE 4"	FOOT	804	0	0	0	0	0	0	0	0	0	0	0	804
78000400	60	THERMOPLASTIC PAVEMENT MARKING - LINE 6"	FOOT	389	57	0	0	0	107	52	0	0	48	0	0	125
78000600	61	THERMOPLASTIC PAVEMENT MARKING - LINE 12"	FOOT	259	0	0	0	48	0	87	64	0	0	0	0	60
78000650	62	THERMOPLASTIC PAVEMENT MARKING - LINE 24"	FOOT	485	14	14	0	12	108	160	12	13	60	92	0	0
78300100	63	PAVEMENT MARKING REMOVAL	SQ FT	590	0	0	0	48	53	0	0	0	0	98	0	391
Z0004514	64	HOT-MIX ASPHALT DRIVEWAY PAVEMENT, 4"	SQ YD	503	80	57	49	33	100	86	0	21	28	0	49	0
Z0004522	65	HOT-MIX ASPHALT DRIVEWAY PAVEMENT, 6"	SQ YD	269	0	0	0	0	0	0	269	0	0	0	0	0
Z0004562	66	COMBINATION CONCRETE CURB AND GUTTER REMOVAL AND REPLACEMENT	FOOT	1,169	190	118	0	72	13	450	18	86	222	0	0	0
Z0013798	67	CONSTRUCTION LAYOUT	L SUM	1												
Z0017400	68	DRAINAGE & UTILITY STRUCTURES TO BE ADJUSTED	EACH	31	0	0	2	0	8	9	7	0	3	2	0	0
Z0017700	69	DRAINAGE & UTILITY STRUCTURES TO BE RECONSTRUCTED	EACH	8	0	1	0	0	0	2	1	2	2	0	0	0
Z0038121	70	PORTLAND CEMENT CONCRETE SURFACE REMOVAL 2"	SQ YD	869	559	0	0	0	0	0	0	310	0	0	0	0
Z0056604	71	STORM SEWER (WATER MAIN REQUIREMENTS) 8 INCH	FOOT	23	0	0	0	0	0	0	23	0	0	0	0	0
Z0056608	72	STORM SEWER (WATER MAIN REQUIREMENTS) 12 INCH	FOOT	138	0	0	0	0	138	0	0	0	0	0	0	0

PLOT DRIVER = ...\\p\dma00314\con_pdf.plt
PEN TABLE = ...\\p\tbl\con_lidat_general.tbl
FILE NAME = ...\\3015-shr-50002.dgn



USER NAME = mjp	DESIGNED - MJP	REVISED -
	DRAWN - MJP	REVISED -
PLOT SCALE = 1:8000' / 1"	CHECKED - DNM	REVISED -
PLOT DATE = 4/14/2016	DATE - 04/15/16	REVISED -

VILLAGE OF VILLA PARK

**2016 STREET IMPROVEMENTS
SUMMARY OF QUANTITIES**

SCALE: N.T.S. SHEET OF SHEETS STA. TO STA.

F.A. RTE.	SECTION	COUNTY	TOTAL SHEETS	SHEET NO.
			62	5
CONTRACT NO.				
ILLINOIS FED. AID PROJECT				

SUMMARY OF QUANTITIES

SUMMARY OF 2016 STREET IMPROVEMENTS					REFERENDUM STREETS							NON-REFERENDUM STREETS				
IDOT CODE NO.	ITEM NO.	ITEM DESCRIPTION	UNIT	TOTAL QUANTITY	HARRISON STREET (STA. 10+38 TO STA. 14+25)	HARRISON STREET (STA. 19+50 TO STA. 23+05)	ORCHARD HILL COURT (STA. 0+00 TO STA. 1+74.4)	LESLIE LANE (STA. 20+32.5 TO STA. 27+50)	MONROE STREET (STA. 30+18.6 TO STA. 56+63)	SUMMIT AVENUE (STA. 55+90 TO STA. 98+10)	HOME AVENUE (STA. 40+10 TO STA. 52+65)	HARRISON STREET (STA. 14+25 TO STA. 19+50)	LESLIE LANE (STA. 27+50 TO STA. 41+62)	WILDFIRE DRIVE (STA. 60+41 TO STA. 72+85)	PRINCETON AVENUE (STA. 84+52 TO STA. 87+13.5)	ARDMORE AVENUE (STA. 166+24 TO STA. 168+71)
Z0062700	73	SAWING P. C. CONCRETE PAVEMENT (FULL DEPTH)	FOOT	1,022	375	0	515	0	0	0	0	132	0	0	0	0
X0327611	74	REMOVE AND REINSTALL BRICK PAVER	SQ FT	76	0	0	0	0	0	0	76	0	0	0	0	0
	75	EXPLORATION TRENCH, SPECIAL	EACH	5	0	1	0	0	1	0	2	1	0	0	0	0
	76	TEMPORARY ACCESS (DRIVEWAY ENTRANCE)	EACH	20	0	0	0	0	0	0	20	0	0	0	0	0
X4023000	77	TEMPORARY ACCESS (ROAD)	EACH	5	0	1	0	0	0	0	2	2	0	0	0	0
X4401198	78	HOT-MIX ASPHALT SURFACE REMOVAL, VARIABLE DEPTH	SQ YD	30,084	604	881	0	1,914	7,793	12,140	1,609	981	3,922	240	0	0
X6026624	79	VALVE BOXES TO BE ADJUSTED (SPECIAL)	EACH	5	0	1	0	0	4	0	0	0	0	0	0	0
X6030310	80	FRAMES AND LIDS TO BE ADJUSTED (SPECIAL)	EACH	45	0	0	0	0	10	27	7	0	1	0	0	0
X6062400	81	CONCRETE GUTTER (SPECIAL)	FOOT	77	0	0	77	0	0	0	0	0	0	0	0	0
X7010216	82	TRAFFIC CONTROL AND PROTECTION, (SPECIAL)	L SUM	1												
XX003668	83	PRECONSTRUCTION VIDEO TAPING	L SUM	1												
XX008188	84	SANITARY SEWER REPAIR, REMOVE AND REPLACE	FOOT	70	0	0	0	0	0	20	50	0	0	0	0	0
	85	SANITARY MANHOLES, 4' -DIAMETER, TYPE 1 FRAME, CLOSED LID	EACH	4	0	0	0	0	0	0	4	0	0	0	0	0
	86	GEOGRID	SQ YD	2,687	0	208	0	0	0	0	2,067	412	0	0	0	0
	87	CONTINGENCY ALLOWANCE	UNIT	30,000												

NOT FOR

PLOT DRIVER = ...\\mjp\dms\0314\con_pdf.plt
PEN TABLE = ...\\pemb\cui\idet_general.tbl
FILE NAME = ...\3015-shr-50003.dgn



USER NAME = mjp	DESIGNED - MJP	REVISED -
	DRAWN - MJP	REVISED -
PLOT SCALE = 1:8000' / 1" =	CHECKED - DNM	REVISED -
PLOT DATE = 4/14/2016	DATE - 04/15/16	REVISED -

VILLAGE OF VILLA PARK

**2016 STREET IMPROVEMENTS
SUMMARY OF QUANTITIES**

SCALE: N.T.S. SHEET OF SHEETS STA. TO STA.

F.A. RTE.	SECTION	COUNTY	TOTAL SHEETS	SHEET NO.
			62	6
CONTRACT NO.				
ILLINOIS FED. AID PROJECT				

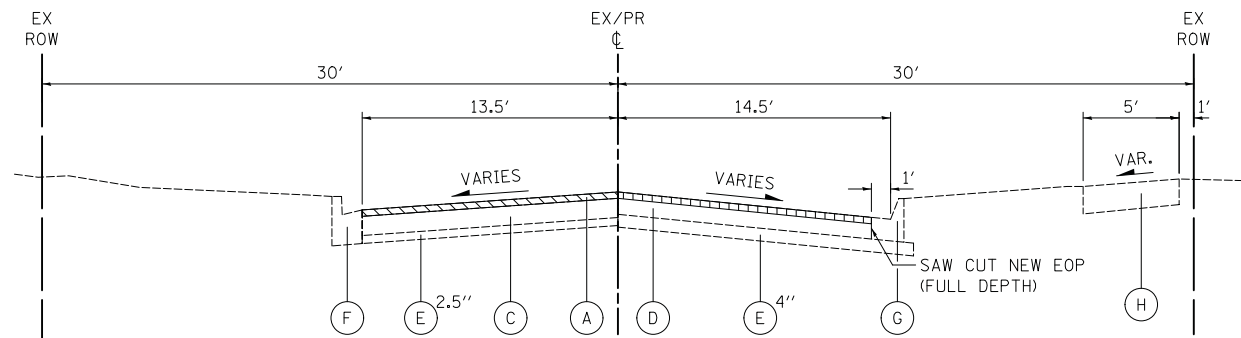

HARRISON STREET – EXISTING TYPICAL SECTION

STA. 10+38 TO STA. 16+33.6

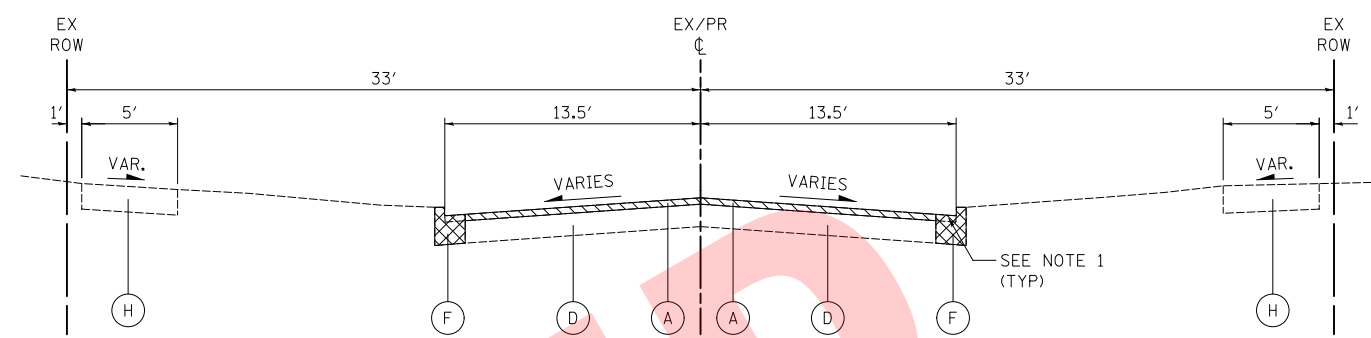

MONROE STREET – EXISTING TYPICAL SECTION

STA. 30+18.6 TO STA. 43+17.5

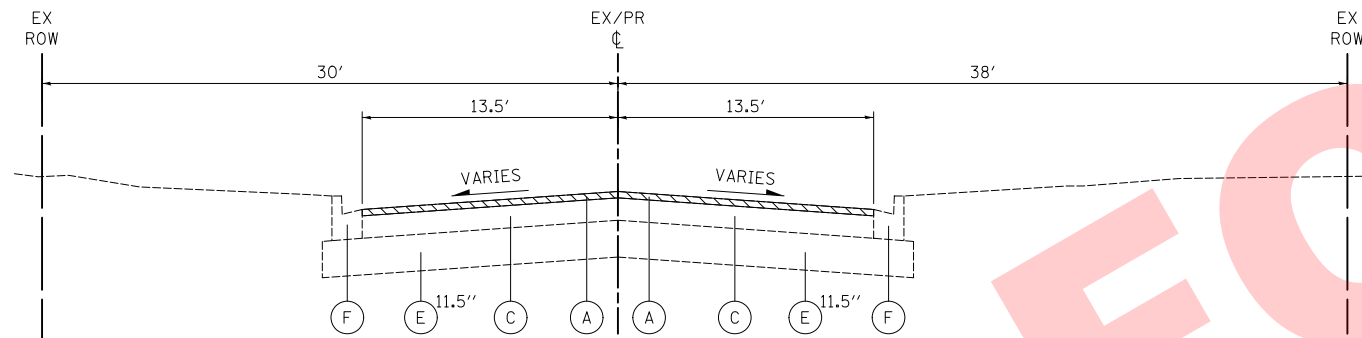

HARRISON STREET – EXISTING TYPICAL SECTION

STA. 16+33.6 TO STA. 23+05

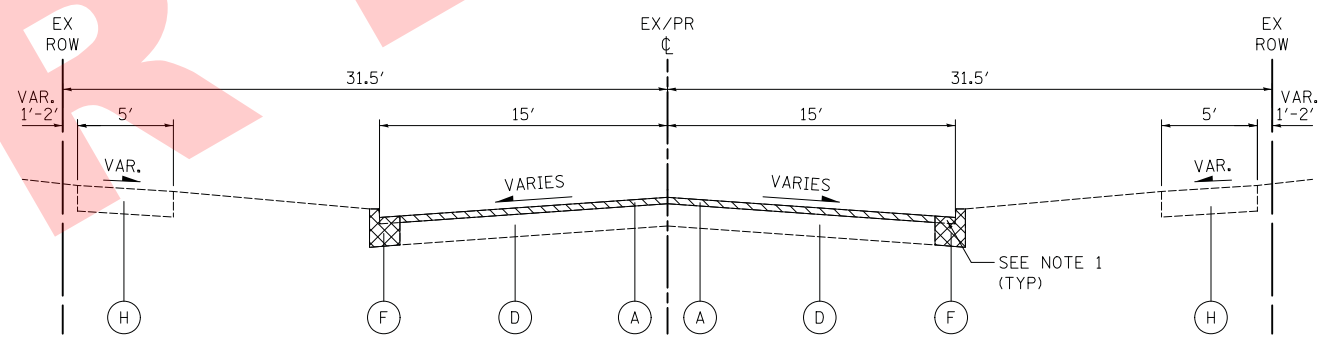

MONROE STREET – EXISTING TYPICAL SECTION

STA. 44+14 TO STA. 56+63

LEGEND

- (A) EXISTING HOT-MIX ASPHALT SURFACE COURSE:
 -HARRISON STREET = 2"
 -MONROE STREET = VARIES 1 1/2" TO 2 1/2"
 -LESLIE LANE = VARIES 2" TO 2 3/4"
 -SUMMIT AVENUE = VARIES 1 1/2" TO 2 1/4"
 -HOME AVENUE = VARIES 1 1/2" TO 2 1/4"
 -PRINCETON AVENUE = 1 3/4"
 - (B) EXISTING CRACK CONTROL FABRIC
 - (C) EXISTING HOT-MIX ASPHALT BINDER COURSE:
 -HARRISON STREET = VARIES 6" TO 7"
 -LESLIE LANE = VARIES 2 3/4" TO 8 3/4"
 -SUMMIT AVENUE = VARIES 4" TO 4 3/4"
 -HOME AVENUE = VARIES 0" TO 7 1/2"
 - (D) EXISTING PORTLAND CEMENT CONCRETE PAVEMENT:
 -HARRISON STREET = 7"
 -ORCHARD HILL COURT = 6 1/2"
 -MONROE STREET = VARIES 6 1/2" TO 7 3/4"
 - (E) EXISTING GRANULAR BASE COURSE:
 -HARRISON STREET = VARIES 2 1/2" TO 11 1/2"
 -ORCHARD HILL COURT = 3 1/2"
 -LESLIE LANE = VARIES 6 3/4" TO 12 1/2"
 -SUMMIT AVENUE = 10"
 -HOME AVENUE = VARIES 3" TO 7 3/4"
 -PRINCETON AVENUE = 10 1/4"
 - (F) EXISTING COMBINATION CURB AND GUTTER, TYPE B-6.12
 - (G) EXISTING MONOLITHIC BARRIER CURB
 - (H) EXISTING PORTLAND CEMENT CONCRETE SIDEWALK
 - (I) EXISTING AGGREGATE SHOULDER
- HOT-MIX ASPHALT SURFACE REMOVAL, VARIABLE DEPTH
 - PORTLAND CEMENT CONCRETE SURFACE REMOVAL 2"
 - COMBINATION CURB AND GUTTER REMOVAL (SEE NOTE 1) DRIVEWAY PAVEMENT REMOVAL (SEE NOTE 2) PAVEMENT REMOVAL
 - EARTH EXCAVATION

NOTES

1. THE REMOVAL OF HMA PAVEMENT AND DRIVEWAY PAVEMENT OVERLAID ON CURB AND GUTTER SHALL BE INCLUDED IN THE COST OF "COMBINATION CURB AND GUTTER REMOVAL".
2. SEE ROADWAY PLANS FOR LIMITS OF DRIVEWAY PAVEMENT REMOVAL.

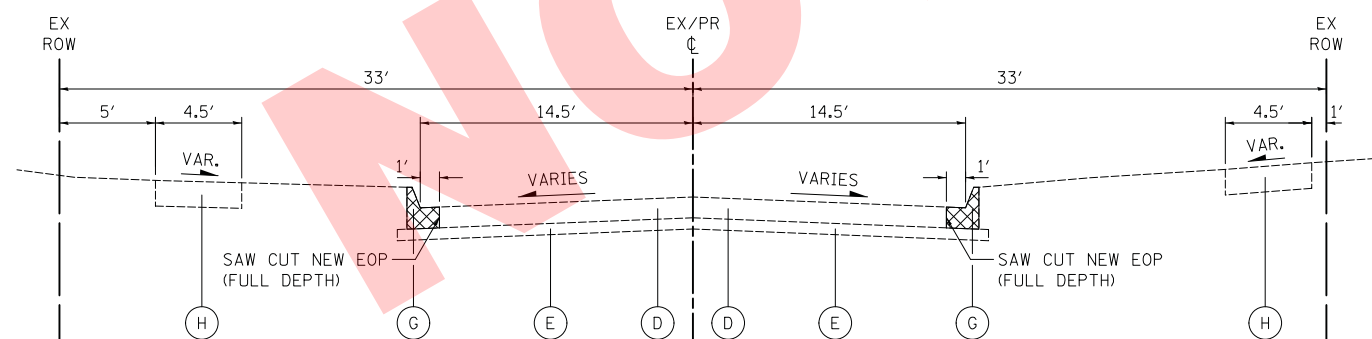

ORCHARD HILL COURT – EXISTING TYPICAL SECTION

STA. 0+00 TO STA. 1+74.4

PLOT DRIVER = ...\\njb\dm00314\...
 PEN TABLE = ...\\njb\dm00314\...
 FILE NAME = ...3015-shr-typrca01.dgn



USER NAME = mjp	DESIGNED - MJP	REVISED -
PLOT SCALE = 1:8000' / 1"	DRAWN - NEM	REVISED -
PLOT DATE = 4/14/2016	CHECKED - DNM	REVISED -
	DATE - 04/15/16	REVISED -

VILLAGE OF VILLA PARK

**2016 STREET IMPROVEMENTS
EXISTING TYPICAL SECTIONS**

SCALE: N.T.S. SHEET OF SHEETS STA. TO STA.

F.A. RTE.	SECTION	COUNTY	TOTAL SHEETS	SHEET NO.
			62	7
			CONTRACT NO.	
ILLINOIS FED. AID PROJECT				

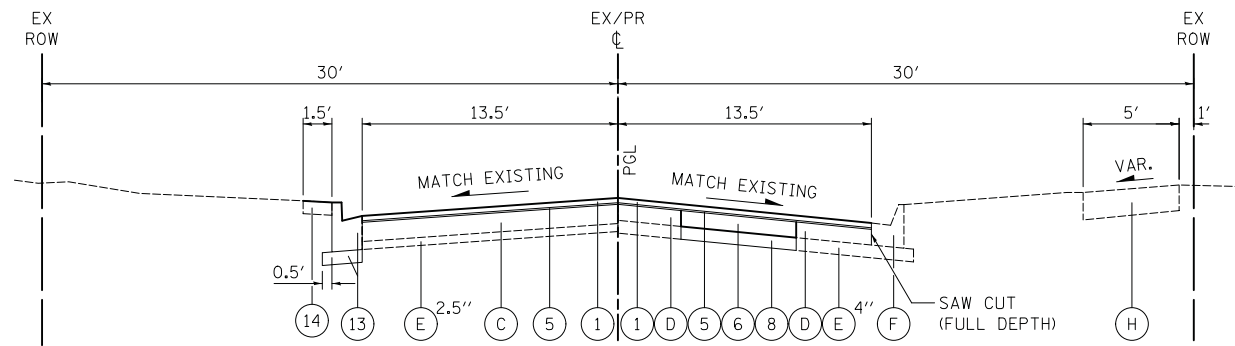

HARRISON STREET – PROPOSED TYPICAL SECTION

STA. 10+38 TO STA. 16+33.6

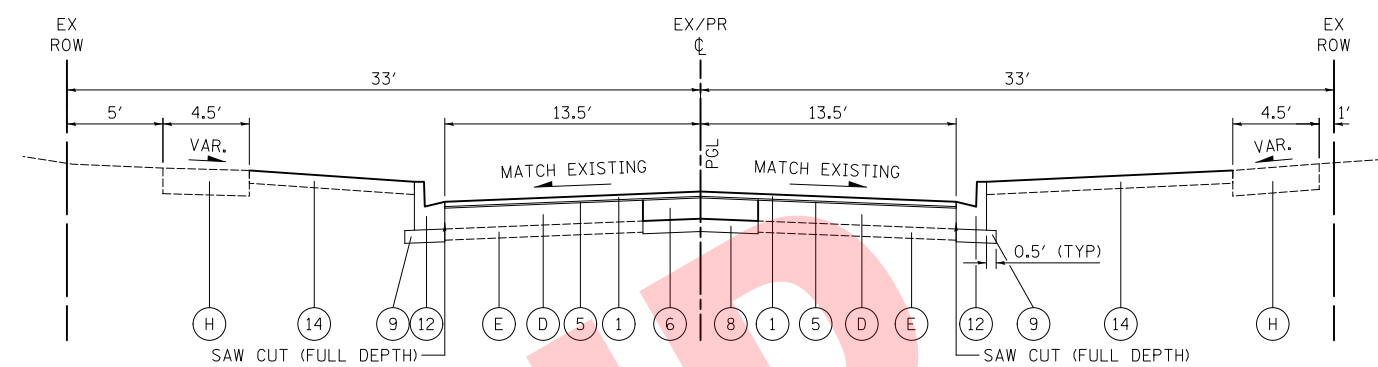

ORCHARD HILL COURT – PROPOSED TYPICAL SECTION

STA. 0+00 TO STA. 1+74.4

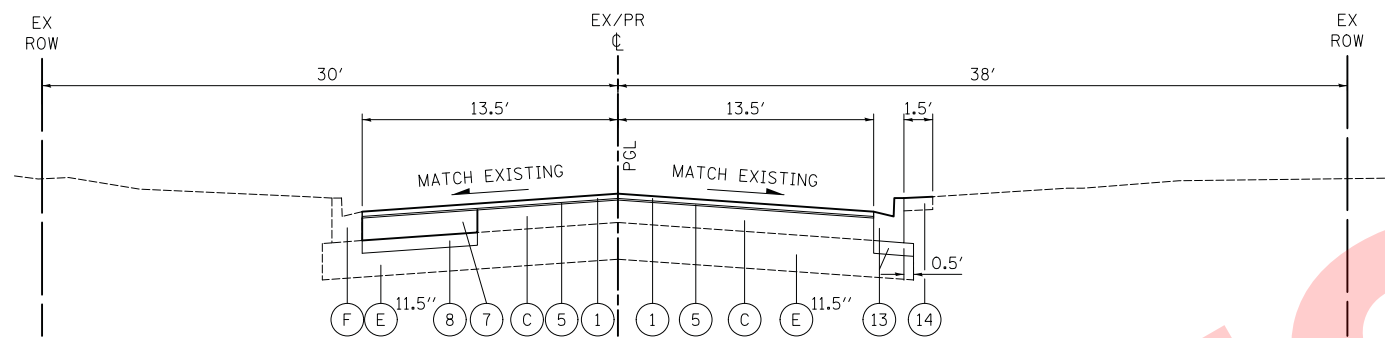

HARRISON STREET – PROPOSED TYPICAL SECTION

STA. 16+33.6 TO STA. 23+05
FROM STA. 18+55 TO STA. 20+10, THE ROADWAY WILL BE RECONSTRUCTED WITH ITEMS 2, 4, 10, 11, AND 12. SEE PROPOSED ROADWAY PLANS FOR ADDITIONAL DETAILS.

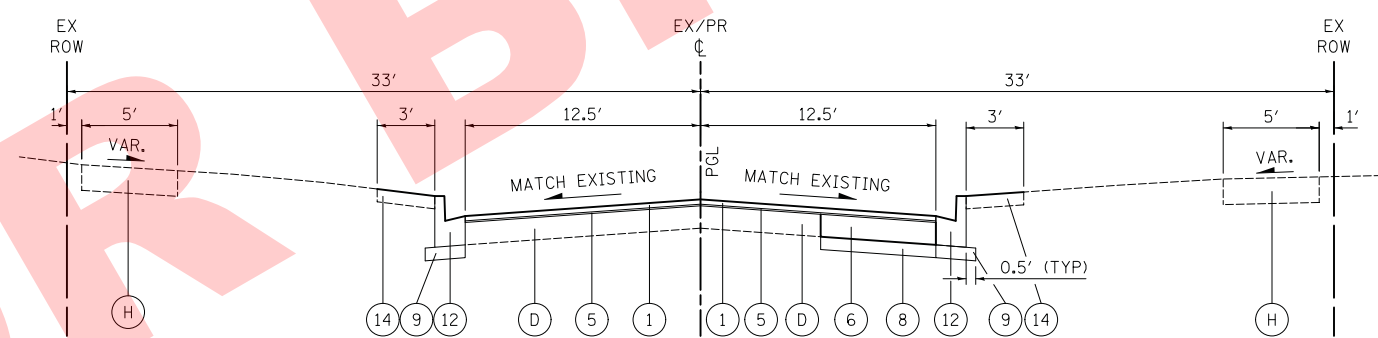

MONROE STREET – PROPOSED TYPICAL SECTION

STA. 30+18.6 TO STA. 43+17.5

LEGEND

- (C) EXISTING HOT-MIX ASPHALT BINDER COURSE:
-HARRISON STREET = VARIES 6" TO 7"
-LESLIE LANE = VARIES 2 3/4" TO 8 3/4"
-SUMMIT AVENUE = VARIES 4" TO 4 3/4"
-HOME AVENUE = VARIES 0" TO 7 1/2"
- (D) EXISTING PORTLAND CEMENT CONCRETE PAVEMENT:
-HARRISON STREET = 7"
-ORCHARD HILL COURT = 6 1/2"
-MONROE STREET = VARIES 6 1/2" TO 7 3/4"
- (E) EXISTING GRANULAR BASE COURSE:
-HARRISON STREET = VARIES 2 1/2" TO 11 1/2"
-ORCHARD HILL COURT = 3 1/2"
-LESLIE LANE = VARIES 6 3/4" TO 12 1/2"
-SUMMIT AVENUE = 10"
-HOME AVENUE = VARIES 3" TO 7 3/4"
-PRINCETON AVENUE = 10 1/4"
- (F) EXISTING COMBINATION CURB AND GUTTER, TYPE B-6.12
- (H) EXISTING PORTLAND CEMENT CONCRETE SIDEWALK
- (1) HOT-MIX ASPHALT SURFACE COURSE, MIX "D", N50, 1 1/2"
- (2) HOT-MIX ASPHALT SURFACE COURSE, MIX "D", N50, 2"
- (3) HOT-MIX ASPHALT BINDER COURSE, IL-19.0, N50, 2 1/2"
- (4) HOT-MIX ASPHALT BINDER COURSE, IL-19.0, N50, 4"
- (5) LEVELING BINDER (MACHINE METHOD), N50, 3/4"
- (6) CLASS C PATCHES, 6 INCH (SEE NOTE 1)
- (7) CLASS D PATCHES, 6 INCH (SEE NOTE 1)
- (8) AGGREGATE BASE COURSE, TYPE B (SEE NOTE 2)
- (9) AGGREGATE BASE COURSE, TYPE B 4"
- (10) AGGREGATE BASE COURSE, TYPE B 8"
- (11) GEOGRID
- (12) COMBINATION CONCRETE CURB AND GUTTER, TYPE B-6.12
- (13) COMBINATION CONCRETE CURB AND GUTTER REMOVAL AND REPLACEMENT (AGGREGATE BASE COURSE, TYPE B, 4" IS INCLUDED IN COST OF ITEM) (SEE NOTE 3)
- (14) TOPSOIL FURNISH AND PLACE, 4" SODDING
- (15) AGGREGATE SHOULDERS, TYPE B 6"

HOT-MIX ASPHALT MIXTURE REQUIREMENTS		
MIXTURE TYPE		AIR VOIDS @ NDES
PAVEMENT RESURFACING		
HOT-MIX ASPHALT SURFACE COURSE, MIX "D", N50 (IL 9.5 mm)		4% @ 50 GYR.
LEVELING BINDER (MACHINE METHOD), N50 (IL 9.5 mm); 3/4"		4% @ 50 GYR.
PAVEMENT RECONSTRUCTION		
HOT-MIX ASPHALT SURFACE COURSE, MIX "D", N50 (IL 9.5 mm)		4% @ 50 GYR.
HOT-MIX ASPHALT BINDER COURSE, IL-19.0, N50		4% @ 50 GYR.
CLASS D PATCHES		
CLASS D PATCH (HMA BINDER IL-19.0 mm)		4% @ 70 GYR.
HOT-MIX ASPHALT BIKE PATH AND DRIVEWAY PAVEMENT, 4"		
HOT-MIX ASPHALT SURFACE COURSE, MIX "D", N50 (IL 9.5 mm); 1.5"		4% @ 50 GYR.
HOT-MIX ASPHALT BINDER COURSE, IL-19.0, N50; 2.5"		4% @ 50 GYR.
HOT-MIX ASPHALT DRIVEWAY PAVEMENT, 6"		
HOT-MIX ASPHALT SURFACE COURSE, MIX "D", N50 (IL 9.5 mm); 2"		4% @ 50 GYR.
HOT-MIX ASPHALT BINDER COURSE, IL-19.0, N50; 4"		4% @ 50 GYR.

THE UNIT WEIGHT USED TO CALCULATE ALL HOT-MIX ASPHALT MIXTURES IS 112 LB/SQ YD/IN. THE "AC-TYPE" FOR NON-POLYMERIZED HMA MIXES SHALL BE "PG 64-22" UNLESS MODIFIED BY DISTRICT ONE SPECIAL PROVISIONS.

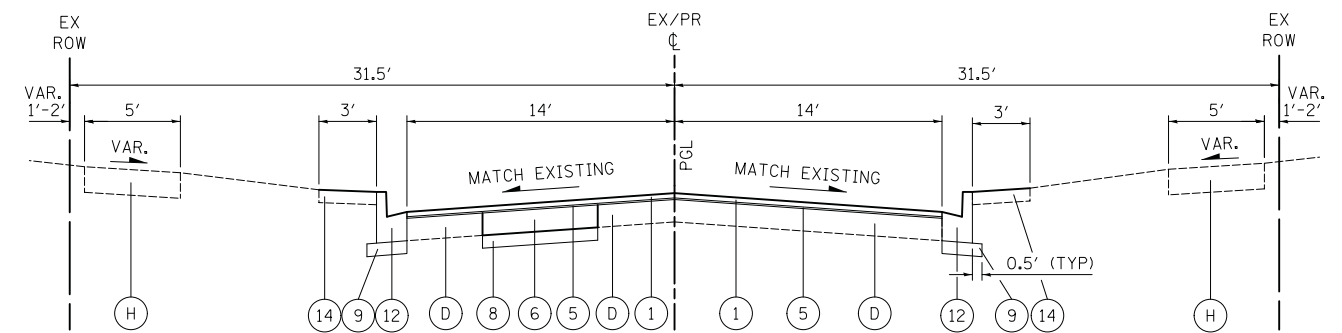

MONROE STREET – PROPOSED TYPICAL SECTION

STA. 44+14 TO STA. 56+63

NOTES

- THE ENGINEER SHALL MAKE THE FINAL DETERMINATION OF THE LOCATION, WIDTH, AND LENGTH OF CLASS C AND CLASS D PATCHES IN THE FIELD.
- DEPENDING ON FIELD CONDITIONS, A MINIMUM OF 4" OF AGGREGATE BASE COURSE, TYPE B WILL BE USED BENEATH PAVEMENT PATCHES AS DIRECTED BY THE ENGINEER.
- THE ENGINEER SHALL MAKE THE FINAL DETERMINATION OF THE LOCATION AND LENGTH OF THE REMOVAL AND REPLACEMENT OF COMBINATION CONCRETE CURB AND GUTTER IN THE FIELD. SEE DISTRICT ONE DETAIL BD-24 "CURB OR CURB AND GUTTER REMOVAL AND REPLACEMENT" FOR ADDITIONAL DETAILS.
- SEE ROADWAY PLANS FOR LIMITS AND MATERIALS OF PROPOSED DRIVEWAY PAVEMENT.

PLOT DRIVER = ...\\n:\p\dms\0314\...
 PEN TABLE = ...\\n:\p\dms\0314\...
 FILE NAME = ...\\n:\p\dms\0314\...



USER NAME = mjp	DESIGNED - MJP	REVISED -
PLOT SCALE = 1:8000' / 1"	DRAWN - NEM	REVISED -
PLOT DATE = 4/14/2016	CHECKED - DNM	REVISED -
	DATE - 04/15/16	REVISED -

VILLAGE OF VILLA PARK

**2016 STREET IMPROVEMENTS
PROPOSED TYPICAL SECTIONS**

SCALE: N.T.S.	SHEET OF SHEETS	STA. TO STA.	F.A. RTE.	SECTION	COUNTY	TOTAL SHEETS	SHEET NO.
						62	9
						CONTRACT NO.	
ILLINOIS FED. AID PROJECT							

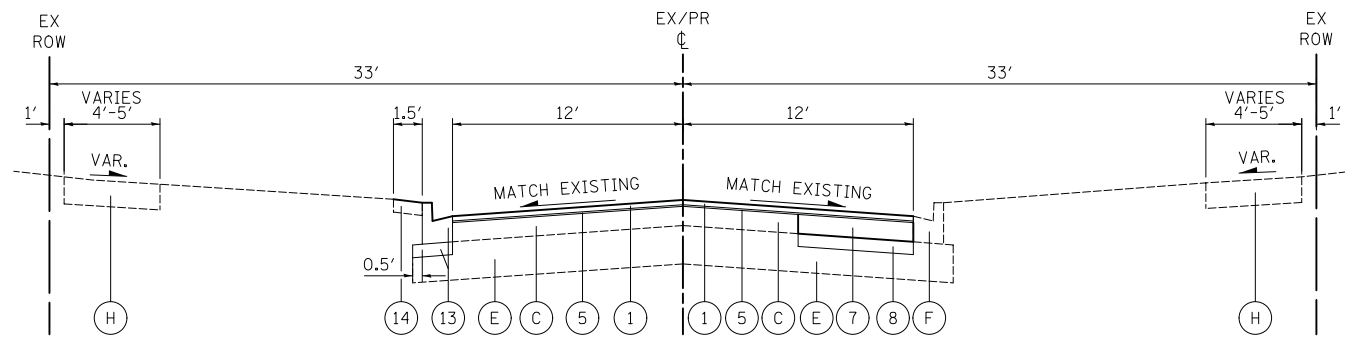

LESLIE LANE – PROPOSED TYPICAL SECTION

STA. 20+32.5 TO STA. 41+62

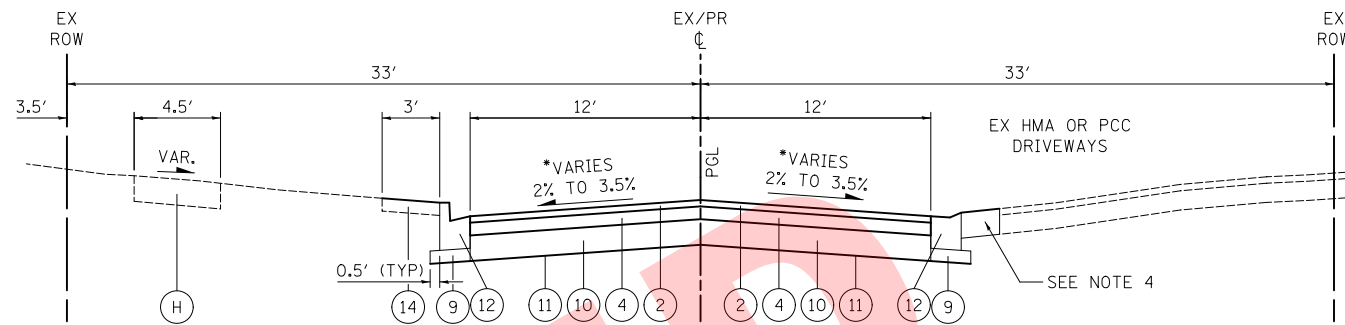

HOME AVENUE – PROPOSED TYPICAL SECTION

STA. 40+10 TO STA. 47+00
*SEE CROSS-SLOPE TRANSITION TABLE IN ROADWAY PLANS

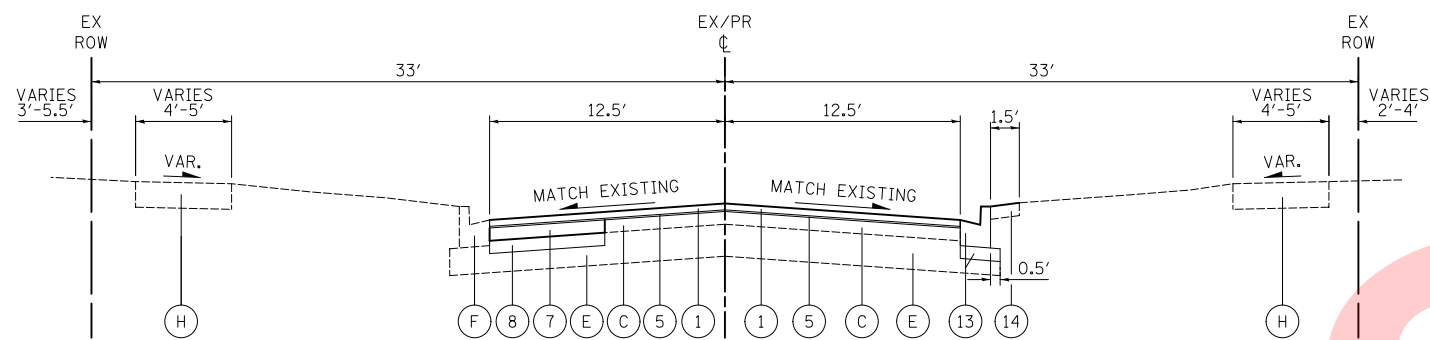

SUMMIT AVENUE – PROPOSED TYPICAL SECTION

STA. 55+90 TO STA. 98+10

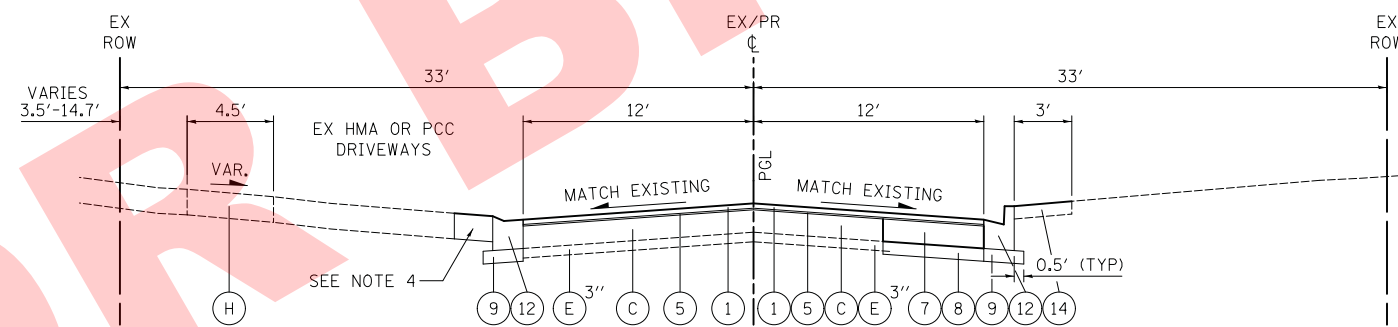

HOME AVENUE – PROPOSED TYPICAL SECTION

STA. 47+00 TO STA. 52+65

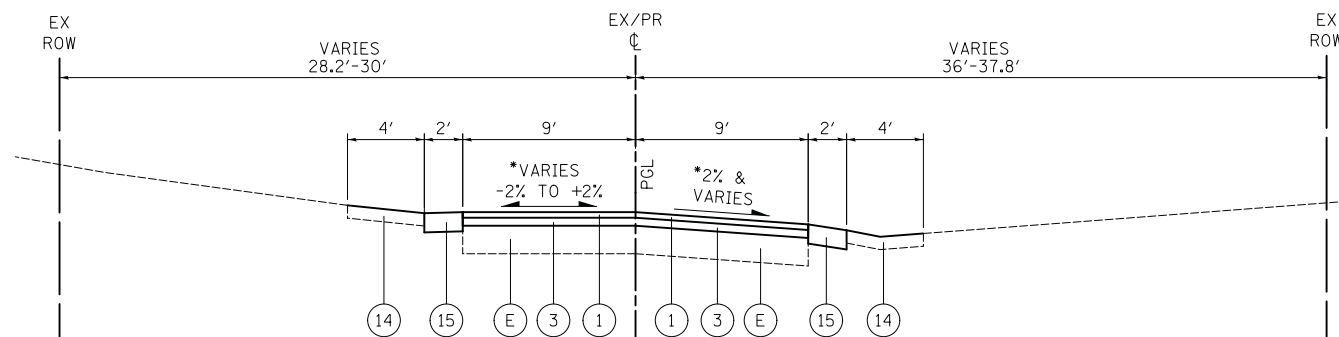

PRINCETON AVENUE – PROPOSED TYPICAL SECTION

STA. 84+52 TO STA. 87+13.5
*SEE CROSS-SLOPE TRANSITION TABLE IN ROADWAY PLANS

LEGEND

- (C) EXISTING HOT-MIX ASPHALT BINDER COURSE:
-HARRISON STREET = VARIES 6" TO 7"
-LESLIE LANE = VARIES 2 3/4" TO 8 3/4"
-SUMMIT AVENUE = VARIES 4" TO 4 3/4"
-HOME AVENUE = VARIES 0" TO 7 1/2"
- (D) EXISTING PORTLAND CEMENT CONCRETE PAVEMENT:
-HARRISON STREET = 7"
-ORCHARD HILL COURT = 6 1/2"
-MONROE STREET = VARIES 6 1/2" TO 7 3/4"
- (E) EXISTING GRANULAR BASE COURSE:
-HARRISON STREET = VARIES 2 1/2" TO 11 1/2"
-ORCHARD HILL COURT = 3 1/2"
-LESLIE LANE = VARIES 6 3/4" TO 12 1/2"
-SUMMIT AVENUE = 10"
-HOME AVENUE = VARIES 3" TO 7 3/4"
-PRINCETON AVENUE = 10 1/4"
- (F) EXISTING COMBINATION CURB AND GUTTER, TYPE B-6.12
- (H) EXISTING PORTLAND CEMENT CONCRETE SIDEWALK
- (1) HOT-MIX ASPHALT SURFACE COURSE, MIX "D", N50, 1 1/2"
- (2) HOT-MIX ASPHALT SURFACE COURSE, MIX "D", N50, 2"
- (3) HOT-MIX ASPHALT BINDER COURSE, IL-19.0, N50, 2 1/2"
- (4) HOT-MIX ASPHALT BINDER COURSE, IL-19.0, N50, 4"
- (5) LEVELING BINDER (MACHINE METHOD), N50, 3/4"
- (6) CLASS C PATCHES, 6 INCH (SEE NOTE 1)
- (7) CLASS D PATCHES, 6 INCH (SEE NOTE 1)
- (8) AGGREGATE BASE COURSE, TYPE B (SEE NOTE 2)
- (9) AGGREGATE BASE COURSE, TYPE B 4"
- (10) AGGREGATE BASE COURSE, TYPE B 8"
- (11) GEOGRID
- (12) COMBINATION CONCRETE CURB AND GUTTER, TYPE B-6.12
- (13) COMBINATION CONCRETE CURB AND GUTTER REMOVAL AND REPLACEMENT (AGGREGATE BASE COURSE, TYPE B, 4" IS INCLUDED IN COST OF ITEM) (SEE NOTE 3)
- (14) TOPSOIL FURNISH AND PLACE, 4" SODDING
- (15) AGGREGATE SHOULDERS, TYPE B 6"

NOTES

1. THE ENGINEER SHALL MAKE THE FINAL DETERMINATION OF THE LOCATION, WIDTH, AND LENGTH OF CLASS C AND CLASS D PATCHES IN THE FIELD.
2. DEPENDING ON FIELD CONDITIONS, A MINIMUM OF 4" OF AGGREGATE BASE COURSE, TYPE B WILL BE USED BENEATH PAVEMENT PATCHES AS DIRECTED BY THE ENGINEER.
3. THE ENGINEER SHALL MAKE THE FINAL DETERMINATION OF THE LOCATION AND LENGTH OF THE REMOVAL AND REPLACEMENT OF COMBINATION CONCRETE CURB AND GUTTER IN THE FIELD. SEE DISTRICT ONE DETAIL BD-24 "CURB OR CURB AND GUTTER REMOVAL AND REPLACEMENT" FOR ADDITIONAL DETAILS.
4. SEE ROADWAY PLANS FOR LIMITS AND MATERIALS OF PROPOSED DRIVEWAY PAVEMENT.

PLOT DRIVER = ...\\p\p\dms00314\...
 PEN TABLE = ...\\p\p\...
 FILE NAME = ...3015-shr-tp\pca0104.dgn



USER NAME = mjp	DESIGNED - MJP	REVISED -
PLOT SCALE = 1.0000' / 1"	DRAWN - NEM	REVISED -
PLOT DATE = 4/14/2016	CHECKED - DNM	REVISED -
	DATE - 04/15/16	REVISED -

VILLAGE OF VILLA PARK

**2016 STREET IMPROVEMENTS
PROPOSED TYPICAL SECTIONS**

SCALE: N.T.S. SHEET OF SHEETS STA. TO STA.

F.A. RTE.	SECTION	COUNTY	TOTAL SHEETS	SHEET NO.
			62	10
			CONTRACT NO.	
ILLINOIS FED. AID PROJECT				

EARTHWORK SCHEDULES

MONROE STREET - EARTHWORK SCHEDULE					
STATION	DISTANCE	EARTH EXCAVATION	REMOVAL AND DISPOSAL OF UNSUITABLE MATERIAL	EARTH EXCAVATION	REMOVAL AND DISPOSAL OF UNSUITABLE MATERIAL
	(FT)	(SQ FT)	(SQ FT)	(CU YD)	(CU YD)
30+18.6		4.7	7.6		
	12.44			6.7	2.6
30+31		24.3	3.8		
	19			9.9	1.9
30+50		3.9	1.6		
	50			7.1	2.8
31+00		3.7	1.4		
	50			7.2	2.4
31+50		4.1	1.2		
	19			4.1	0.4
31+69		7.5	0.0		
	31			6.4	0.8
32+00		3.6	1.4		
	50			7.0	2.8
32+50		4.0	1.6		
	50			7.3	2.8
33+00		3.9	1.4		
	50			7.0	2.6
33+50		3.6	1.4		
	50			6.9	2.6
34+00		3.8	1.5		
	50			10.8	10.0
34+50		7.8	9.3		
	5.53			3.2	1.0
34+55.53		23.2	0.0		
	30			12.9	0.0
34+85.53		0.0	0.0		
	30			13.0	0.0
35+15.53		23.3	0.0		
	34.47			17.4	0.9
35+50		3.9	1.4		
	50			7.2	2.5
36+00		3.8	1.3		
	50			7.2	2.8
36+50		4.0	1.7		
	50			7.4	3.3
37+00		4.0	1.8		
	50			7.5	3.4
37+50		4.1	1.9		
	50			7.5	3.6
38+00		4.0	2.0		
	50			7.0	2.8
38+50		3.5	1.0		
	50			6.8	2.6
39+00		3.8	1.8		
	50			7.2	3.3
39+50		3.9	1.8		
	50			7.1	3.0
40+00		3.7	1.4		
	50			7.0	2.7
40+50		3.8	1.5		
	50			7.0	2.5
41+00		3.8	1.2		
	50			7.0	2.5
41+50		3.8	1.5		
	31			6.8	0.8
41+81		8.1	0.0		
	14			3.2	1.8
41+95		4.2	6.8		
	55			8.1	8.6
42+50		3.8	1.6		
	50			7.2	3.2
43+00		3.9	1.8		

MONROE STREET - EARTHWORK SCHEDULE					
STATION	DISTANCE	EARTH EXCAVATION	REMOVAL AND DISPOSAL OF UNSUITABLE MATERIAL	EARTH EXCAVATION	REMOVAL AND DISPOSAL OF UNSUITABLE MATERIAL
	(FT)	(SQ FT)	(SQ FT)	(CU YD)	(CU YD)
43+00		3.9	1.8		
	17.5			2.5	1.2
43+17.50		3.8	1.8		
GAP IMPROVEMENTS AT ARDMORE AVENUE					
44+14		3.8	1.8		
	36			4.9	2.1
44+50		3.6	1.4		
	45			6.1	2.1
44+95		3.6	1.1		
	42			8.0	6.2
45+37		6.7	6.9		
	13			3.6	1.7
45+50		8.3	0.0		
	50			11.2	1.3
46+00		3.7	1.4		
	45			6.3	2.4
46+45		3.8	1.5		
	55			7.8	2.9
47+00		3.8	1.3		
	50			7.0	2.6
47+50		3.7	1.4		
	31			17.7	0.8
47+81		27.1	0.0		
	27			13.6	0.0
48+08		0.0	0.0		
	28			9.8	0.0
48+36		19.0	0.0		
	39			16.2	1.0
48+75		3.5	1.3		
	50			6.4	2.5
49+25		3.4	1.3		
	50			6.2	2.3
49+75		3.3	1.2		
	55			6.8	2.5
50+30		3.3	1.3		
	45			5.6	2.1
50+75		3.4	1.2		
	50			6.3	2.5
51+25		3.4	1.5		
	50			6.4	2.6
51+75		3.5	1.3		
	25			3.2	1.2
52+00		3.5	1.4		
	50			6.9	3.0
52+50		3.9	1.9		
	50			6.8	3.0
53+00		3.4	1.4		
	50			6.3	2.8
53+50		3.4	1.6		
	50			6.4	2.9
54+00		3.5	1.5		
	50			6.5	2.7
54+50		3.5	1.5		
	55			8.5	4.4
55+05		4.8	2.9		
	14			2.1	0.7
55+19		3.4	0.0		
	56			7.3	1.5
55+75		3.6	1.4		
	21			2.8	1.1
55+96		3.6	1.4		
	29			3.8	1.5
56+25		3.6	1.5		

MONROE STREET - EARTHWORK SCHEDULE					
STATION	DISTANCE	EARTH EXCAVATION	REMOVAL AND DISPOSAL OF UNSUITABLE MATERIAL	EARTH EXCAVATION	REMOVAL AND DISPOSAL OF UNSUITABLE MATERIAL
	(FT)	(SQ FT)	(SQ FT)	(CU YD)	(CU YD)
56+25		3.6	1.5		
	29			3.7	1.6
56+54		3.3	1.4		
	4.5			1.2	0.1
56+58.50		11.4	0.0		
	4.5			1.2	0.3
56+63		3.3	4.1		
SUB-TOTAL =				456.9	148.9
DRIVEWAY APRONS =				79.6	0.0
UNDERCUTTING FOR PAVEMENT PATCHES =				0.0	86.4
MONROE STREET TOTAL =				536.5	235.2

PRINCETON AVENUE - EARTHWORK SCHEDULE					
STATION	DISTANCE	EARTH EXCAVATION	REMOVAL AND DISPOSAL OF UNSUITABLE MATERIAL	EARTH EXCAVATION	REMOVAL AND DISPOSAL OF UNSUITABLE MATERIAL
	(FT)	(SQ FT)	(SQ FT)	(CU YD)	(CU YD)
84+52		6.6	3.5		
	23			4.8	3.3
84+75		4.7	4.4		
	25			3.9	3.5
85+00		3.8	3.2		
	25			4.6	2.3
85+25		6.1	1.8		
	40			8.2	3.1
85+65		4.9	2.4		
	26.5			3.9	1.9
85+91.50		3.0	1.5		
	28.5			3.6	1.4
86+20		3.8	1.1		
	25			5.1	1.2
86+45		7.2	1.5		
	12			3.6	0.3
86+57		9.0	0.0		
	28			8.3	0.0
86+85		7.0	0.0		
	15			3.8	0.6
87+00		6.6	2.2		
	13.5			5.9	1.2
87+13.50		16.8	2.5		
SUB-TOTAL =				55.6	18.8
DRIVEWAY APRONS =				9.9	0.0
PRINCETON AVENUE TOTAL =				65.5	18.8

WILDFIRE DRIVE - EARTHWORK SCHEDULE		
LOCATION	EARTH EXCAVATION	REMOVAL AND DISPOSAL OF UNSUITABLE MATERIAL
	(CU YD)	(CU YD)
UNDERCUTTING FOR PAVEMENT PATCHES	0.0	23.6
WILDFIRE DRIVE TOTAL =	0.0	23.6

NOTES

- UNDERCUTTING FOR PAVEMENT PATCHES WILL BE DETERMINED BY THE ENGINEER IN THE FIELD BASED ON EXISTING SUB-BASE AND SUBGRADE CONDITIONS. IF THE MATERIAL IS DEEMED UNSUITABLE OR UNSTABLE, THE ENGINEER WILL DIRECT THE CONTRACTOR TO REMOVE IT. ALL PAVEMENT PATCHES HAVE AN UNDERCUT CONTINGENCY OF 4" IN DEPTH WHICH WILL BE REMOVED AND PAID FOR AS "REMOVAL AND DISPOSAL OF UNSUITABLE MATERIAL".

PLOT DRIVER = ...\\n:\p\dms\0314\con_paf.p1t
 PEN TABLE = ...\\n:\p\dms\0314\con_paf.p1t
 FILE NAME = ...\\n:\p\dms\0314\con_paf.p1t



USER NAME = mjp	DESIGNED - NEM	REVISED -
	DRAWN - MJP	REVISED -
PLOT SCALE = 1:8000' / 1"	CHECKED - DNM	REVISED -
PLOT DATE = 4/14/2016	DATE - 04/15/16	REVISED -

VILLAGE OF VILLA PARK

2016 STREET IMPROVEMENTS EARTHWORK SCHEDULES

SCALE: N.T.S. SHEET OF SHEETS STA. TO STA.

F.A. RTE.	SECTION	COUNTY	TOTAL SHEETS	SHEET NO.
		DUPAGE	62	12
CONTRACT NO.				
ILLINOIS FED. AID PROJECT				

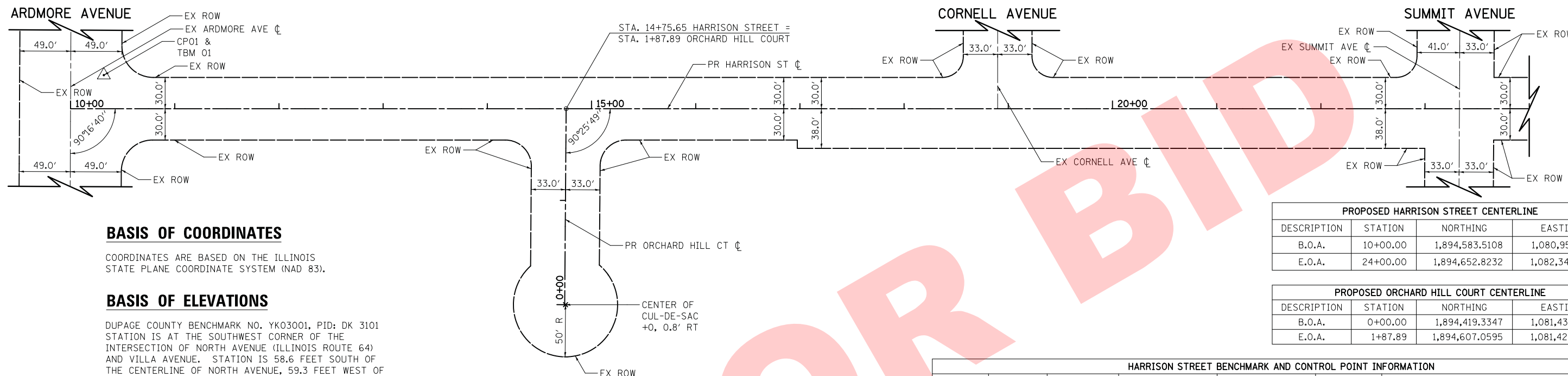

BASIS OF COORDINATES

COORDINATES ARE BASED ON THE ILLINOIS STATE PLANE COORDINATE SYSTEM (NAD 83).

BASIS OF ELEVATIONS

DUPAGE COUNTY BENCHMARK NO. YK03001, PID: DK 3101 STATION IS AT THE SOUTHWEST CORNER OF THE INTERSECTION OF NORTH AVENUE (ILLINOIS ROUTE 64) AND VILLA AVENUE. STATION IS 58.6 FEET SOUTH OF THE CENTERLINE OF NORTH AVENUE, 59.3 FEET WEST OF THE CENTERLINE OF VILLA AVENUE, AND 26.5 FEET NORTHWEST OF A FIRE HYDRANT. MONUMENT IS 1.2 FEET ABOVE ROAD SURFACE ON A 2.5 FOOT DIAMETER CONCRETE TRAFFIC SIGNAL BASE AND IS FERRO MAGNETIC. ELEVATION 679.61 N.G.V.D. 1988 DATUM.

PROPOSED HARRISON STREET CENTERLINE			
DESCRIPTION	STATION	NORTHING	EASTING
B.O.A.	10+00.00	1,894,583.5108	1,080,950.4181
E.O.A.	24+00.00	1,894,652.8232	1,082,348.7013

PROPOSED ORCHARD HILL COURT CENTERLINE			
DESCRIPTION	STATION	NORTHING	EASTING
B.O.A.	0+00.00	1,894,419.3347	1,081,433.3733
E.O.A.	1+87.89	1,894,607.0595	1,081,425.4807

HARRISON STREET BENCHMARK AND CONTROL POINT INFORMATION						
BM / CP	STATION	OFFSET	NORTHING	EASTING	ELEVATION	DESCRIPTION
TBM01 CP01	10+31.95	32.18' LT	1,894,617.2380	1,080,980.7360	694.91	MOST NORTHERLY NORTHWEST FLANGE BOLT ON FIRE HYDRANT LOCATED AT THE NORTHEAST CORNER OF HARRISON STREET AND ARDMORE AVENUE

PROPOSED HOME AVENUE CENTERLINE			
DESCRIPTION	STATION	NORTHING	EASTING
B.O.A.	40+00.00	1,902,278.5179	1,079,364.2180
E.O.A.	53+35.52	1,902,276.6273	1,080,699.7333

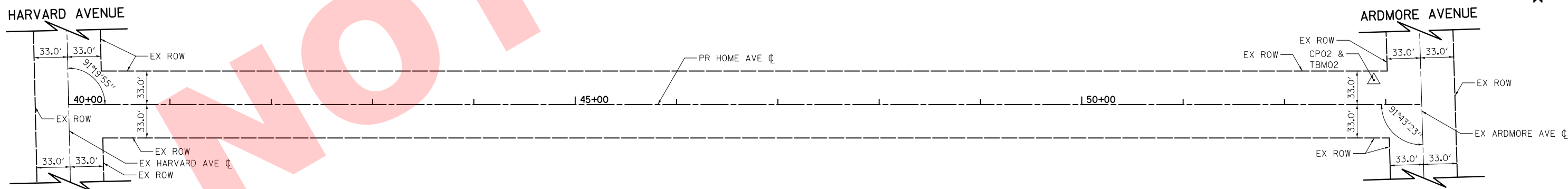

HOME AVENUE BENCHMARK AND CONTROL POINT INFORMATION						
BM / CP	STATION	OFFSET	NORTHING	EASTING	ELEVATION	DESCRIPTION
TBM02 CP02	52+88.25	24.01' LT	1,902,300.7069	1,080,652.5004	695.03	MOST NORTHERLY NORTHWEST FLANGE BOLT ON FIRE HYDRANT LOCATED AT THE NORTHWEST CORNER OF HOME AND ARDMORE AVENUE

BASIS OF COORDINATES

COORDINATES ARE BASED ON THE ILLINOIS STATE PLANE COORDINATE SYSTEM (NAD 83).

BASIS OF ELEVATIONS

DUPAGE COUNTY BENCHMARK NO. YK03001, PID: DK 3101 STATION IS AT THE SOUTHWEST CORNER OF THE INTERSECTION OF NORTH AVENUE (ILLINOIS ROUTE 64) AND VILLA AVENUE. STATION IS 58.6 FEET SOUTH OF THE CENTERLINE OF NORTH AVENUE, 59.3 FEET WEST OF THE CENTERLINE OF VILLA AVENUE, AND 26.5 FEET NORTHWEST OF A FIRE HYDRANT. MONUMENT IS 1.2 FEET ABOVE ROAD SURFACE ON A 2.5 FOOT DIAMETER CONCRETE TRAFFIC SIGNAL BASE AND IS FERRO MAGNETIC. ELEVATION 679.61 N.G.V.D. 1988 DATUM.



PLOT DRIVER = ...\\n:\p\dms\0314\ven_pdf.plt
PEN TABLE = ...\\p\entb\pen.tbl
FILE NAME = ...\\3015-shr-ATB01.dgn



USER NAME = mjp	DESIGNED - MJP	REVISED -
PLOT SCALE = 50.0000' / in.	DRAWN - NEM	REVISED -
PLOT DATE = 4/14/2016	CHECKED - DNM	REVISED -
	DATE - 04/15/16	REVISED -

VILLAGE OF VILLA PARK

**HARRISON STREET, ORCHARD HILL COURT AND HOME AVENUE
ALIGNMENT, TIES AND BENCHMARKS**

SCALE: 1" = 50' SHEET OF SHEETS STA. TO STA.

F.A. RTE.	SECTION	COUNTY	TOTAL SHEETS	SHEET NO.
		DUPAGE	62	13
CONTRACT NO.				
ILLINOIS FED. AID PROJECT				

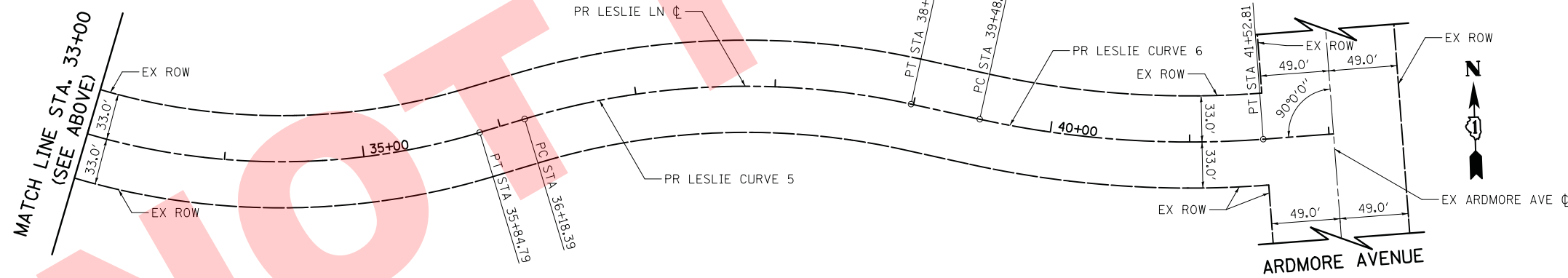
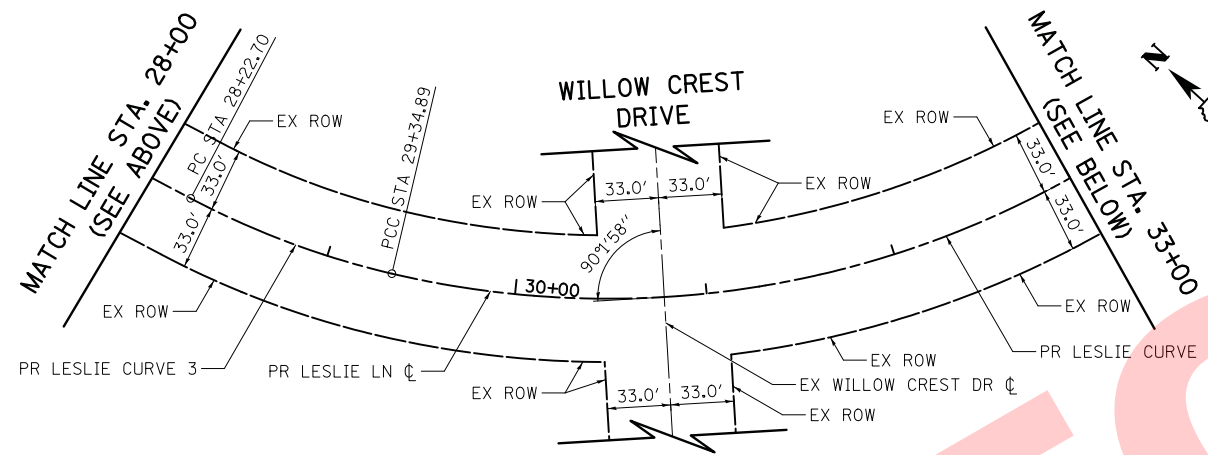
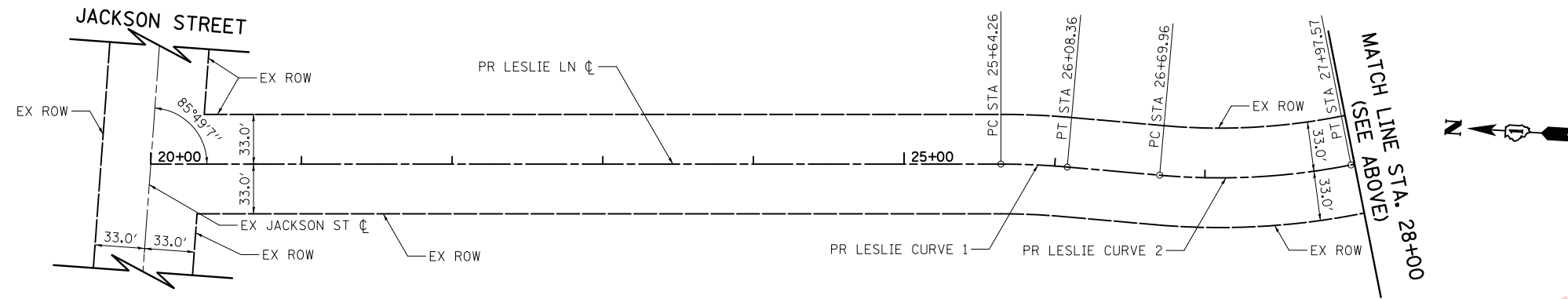

PROPOSED LESLIE LANE CENTERLINE			
DESCRIPTION	STATION	NORTHING	EASTING
B.O.A.	20+00.00	1,895,918.5864	1,079,679.0709
P.C.	25+64.26	1,895,355.4313	1,079,713.3728
P.I.	25+86.32	1,895,333.4112	1,079,714.7531
P.T.	26+08.36	1,895,311.3552	1,079,714.1886
P.C.	26+69.96	1,895,249.7753	1,079,712.6123
P.I.	27+34.20	1,895,185.5596	1,079,710.9685
P.T.	27+97.57	1,895,123.4488	1,079,727.3577
P.C.	28+22.70	1,895,099.1477	1,079,733.7700
P.I.	28+79.10	1,895,044.6132	1,079,748.1600
P.C.C.	29+34.89	1,894,995.4713	1,079,775.8397
P.I.	33+16.96	1,894,662.5784	1,079,963.3453
P.T.	35+84.79	1,894,761.4491	1,080,332.3990
P.C.	36+18.39	1,894,770.1434	1,080,364.8523
P.I.	37+61.41	1,894,807.1539	1,080,503.0008
P.T.	38+98.23	1,894,772.1793	1,080,641.6787
P.C.	39+48.60	1,894,759.8625	1,080,690.5161
P.I.	40+51.43	1,894,734.7148	1,080,790.2291
P.T.	41+52.81	1,894,739.3079	1,080,892.9618
E.O.A.	42+03.25	1,894,741.5609	1,080,943.3518

PR LESLIE CURVE 1
 PI STA. = 25+86.32
 $\Delta = 5^\circ 03' 12''$ (RT)
 $D = 11^\circ 27' 33''$
 $R = 500.00'$
 $T = 22.06'$
 $L = 44.10'$
 $E = 0.49'$
 P.C. STA. = 25+64.26
 P.T. STA. = 26+08.36

PR LESLIE CURVE 2
 PI STA. = 27+34.20
 $\Delta = 16^\circ 14' 53''$ (LT)
 $D = 12^\circ 43' 57''$
 $R = 450.00'$
 $T = 64.24'$
 $L = 127.61'$
 $E = 4.56'$
 P.C. STA. = 26+69.96
 P.T. STA. = 27+97.57

PR LESLIE CURVE 3
 PI STA. = 28+79.10
 $\Delta = 14^\circ 36' 33''$ (LT)
 $D = 13^\circ 01' 18''$
 $R = 440.00'$
 $T = 56.40'$
 $L = 112.19'$
 $E = 3.60'$
 P.C. STA. = 28+22.70
 P.T. STA. = 29+34.89

PR LESLIE CURVE 4
 PI STA. = 33+16.96
 $\Delta = 75^\circ 36' 24''$ (LT)
 $D = 11^\circ 38' 01''$
 $R = 492.50'$
 $T = 382.07'$
 $L = 649.90'$
 $E = 130.82'$
 P.C. STA. = 29+34.89
 P.T. STA. = 35+84.79

PR LESLIE CURVE 5
 PI STA. = 37+61.41
 $\Delta = 29^\circ 09' 09''$ (RT)
 $D = 10^\circ 25' 03''$
 $R = 550.00'$
 $T = 143.02'$
 $L = 279.84'$
 $E = 18.29'$
 P.C. STA. = 36+18.39
 P.T. STA. = 38+98.23

PR LESLIE CURVE 6
 PI STA. = 40+51.43
 $\Delta = 16^\circ 42' 53''$ (LT)
 $D = 8^\circ 11' 06''$
 $R = 700.00'$
 $T = 102.84'$
 $L = 204.21'$
 $E = 7.51'$
 P.C. STA. = 39+48.60
 P.T. STA. = 41+52.81

BASIS OF COORDINATES

LESLIE LANE WAS NOT SURVEYED AND DOES NOT HAVE ANY CONTROL POINTS. THE CENTERLINE IS ONLY A BEST-FIT APPROXIMATION REPRESENTING THE CENTER OF ROADWAY AND CENTER OF RIGHT-OF-WAY. AERIAL IMAGERY WAS USED TO CREATE THE CENTERLINE WHICH IS BASED ON THE ILLINOIS STATE PLANE COORDINATE SYSTEM (NAD 83).

BASIS OF ELEVATIONS

LESLIE LANE WAS NOT SURVEYED AND DOES NOT HAVE A BASIS OF ELEVATION OR ANY TEMPORARY BENCHMARKS.

PLT DRIVER = ...
 PEN TABLE = ...
 FILE NAME = ...



USER NAME = mjp	DESIGNED - MJP	REVISED -
	DRAWN - NEM	REVISED -
PLOT SCALE = 50.0000' / in.	CHECKED - DNM	REVISED -
PLOT DATE = 4/14/2016	DATE - 04/15/16	REVISED -

VILLAGE OF VILLA PARK

**LESLIE LANE AND PRINCETON AVENUE
ALIGNMENT, TIES AND BENCHMARKS**

SCALE: 1" = 50' SHEET OF SHEETS STA. TO STA.

F.A. RTE.	SECTION	COUNTY	TOTAL SHEETS	SHEET NO.
		DUPAGE	62	14
CONTRACT NO.				
ILLINOIS FED. AID PROJECT				

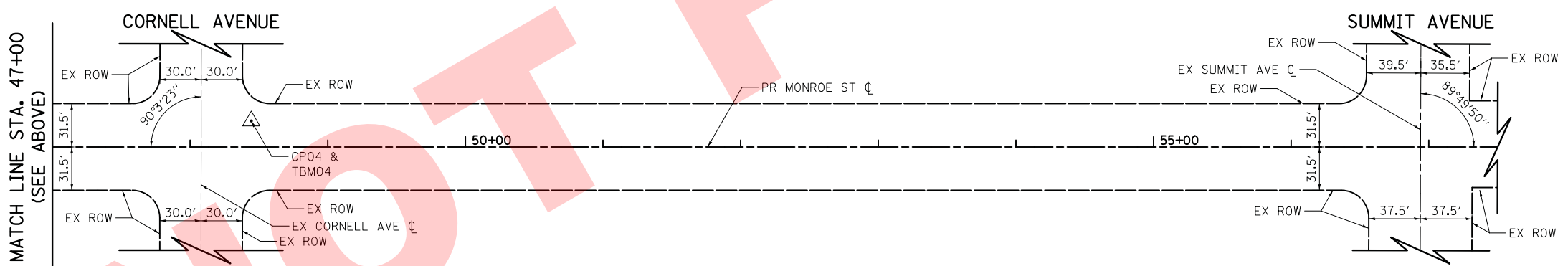
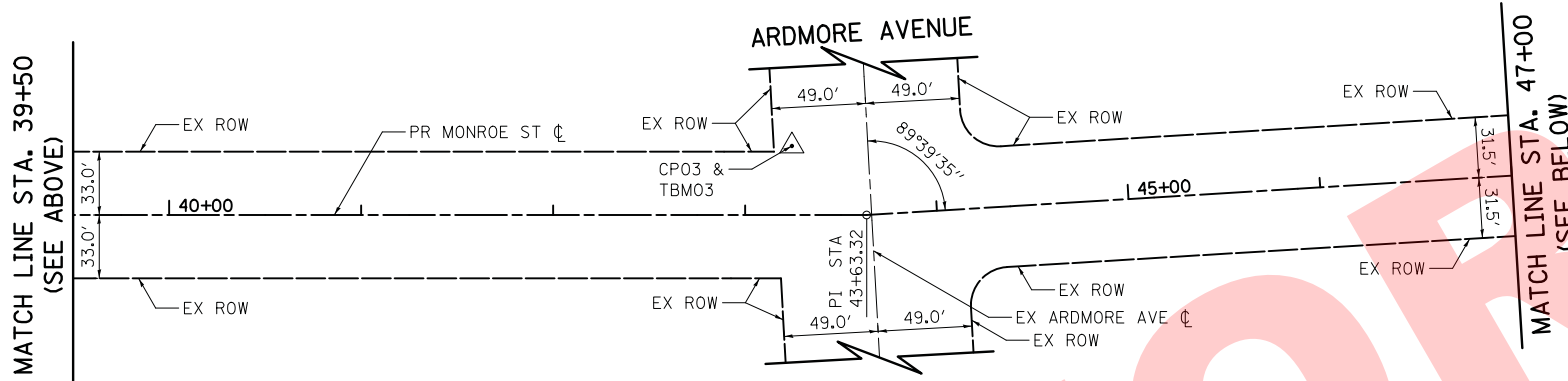
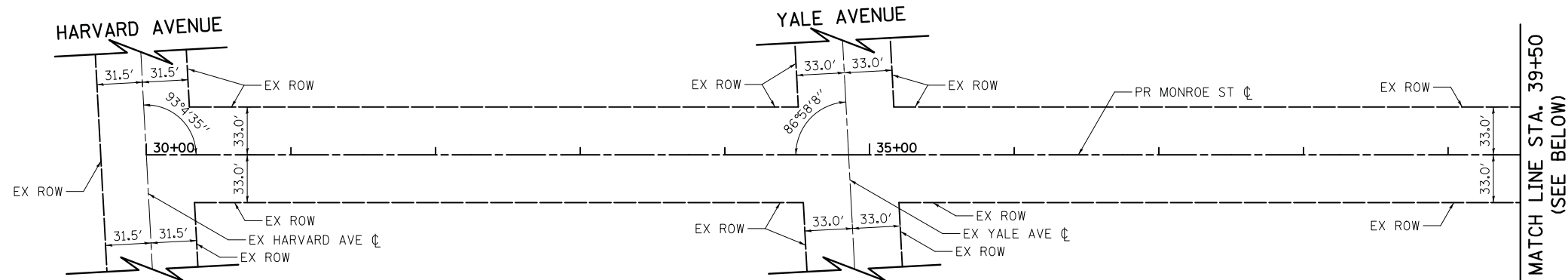

PROPOSED MONROE STREET CENTERLINE			
DESCRIPTION	STATION	NORTHING	EASTING
B.O.A.	30+00.00	1,896,807.5816	1,079,487.7181
P.I.	43+63.32	1,896,791.5282	1,080,850.9444
E.O.A.	57+50.00	1,896,589.6652	1,082,235.9486

MONROE STREET BENCHMARK AND CONTROL POINT INFORMATION						
BM / CP	STATION	OFFSET	NORTHING	EASTING	ELEVATION	DESCRIPTION
TBM03 CP03	43+24.41	38.36' LT	1,896,830.3390	1,080,812.4920	698.58	MOST WESTERLY NORTHWEST FLANGE BOTL ON FIRE HYDRANT LOCATED AT THE NORTHWEST CORNER OF MONROE AND ARDMORE AVENUE
TBM04 CP04	48+44.60	21.23' LT	1,896,836.3830	1,081,330.6020	698.95	MOST NORTHERLY NORTHWEST FLANGE BOLT ON FIRE HYDRANT LOCATED AT THE NORTHEAST CORNER OF MONROE AND CORNELL AVENUE

BASIS OF COORDINATES

COORDINATES ARE BASED ON THE ILLINOIS STATE PLANE COORDINATE SYSTEM (NAD 83).

BASIS OF ELEVATIONS

DUPAGE COUNTY BENCHMARK NO. YK03001, PID: DK 3101 STATION IS AT THE SOUTHWEST CORNER OF THE INTERSECTION OF NORTH AVENUE (ILLINOIS ROUTE 64) AND VILLA AVENUE. STATION IS 58.6 FEET SOUTH OF THE CENTERLINE OF NORTH AVENUE, 59.3 FEET WEST OF THE CENTERLINE OF VILLA AVENUE, AND 26.5 FEET NORTHWEST OF A FIRE HYDRANT. MONUMENT IS 1.2 FEET ABOVE ROAD SURFACE ON A 2.5 FOOT DIAMETER CONCRETE TRAFFIC SIGNAL BASE AND IS FERRO MAGNETIC. ELEVATION 679.61 N.G.V.D. 1988 DATUM.

PLOT DRIVER = ...\\njb\dm00314\monr.pdf.plt
PEN TABLE = ...\\njb\dm00314\monr.pen.tbl
FILE NAME = ...\\3015-shr-ATB03.dgn



USER NAME = mjp	DESIGNED - MJP	REVISED -
	DRAWN - NEM	REVISED -
PLOT SCALE = 50.0000' / in.	CHECKED - DNM	REVISED -
PLOT DATE = 4/14/2016	DATE - 04/15/16	REVISED -

VILLAGE OF VILLA PARK

**MONROE STREET
ALIGNMENT, TIES AND BENCHMARKS**

SCALE: 1" = 50' SHEET OF SHEETS STA. TO STA.

F.A. RTE.	SECTION	COUNTY	TOTAL SHEETS	SHEET NO.
		DUPAGE	62	15
CONTRACT NO.				
ILLINOIS FED. AID PROJECT				

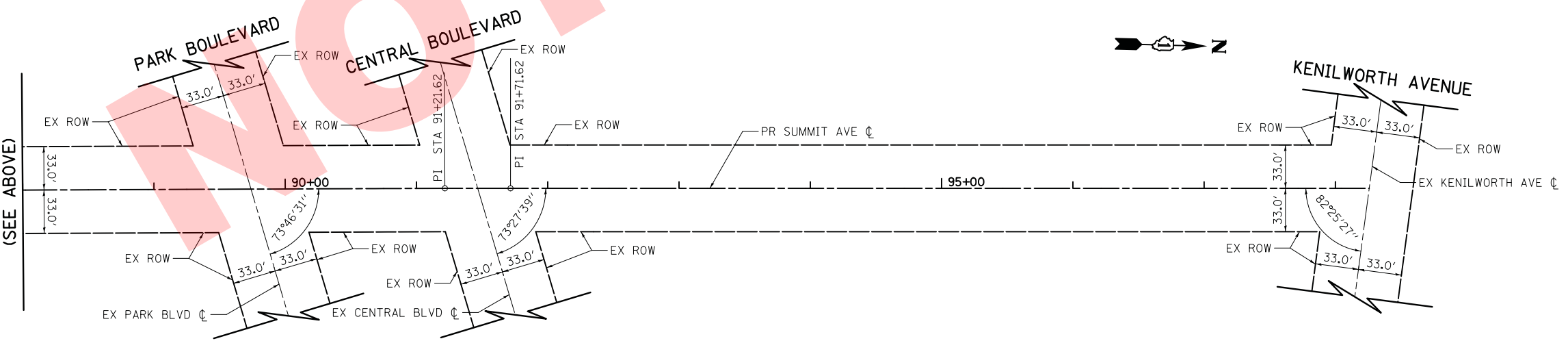
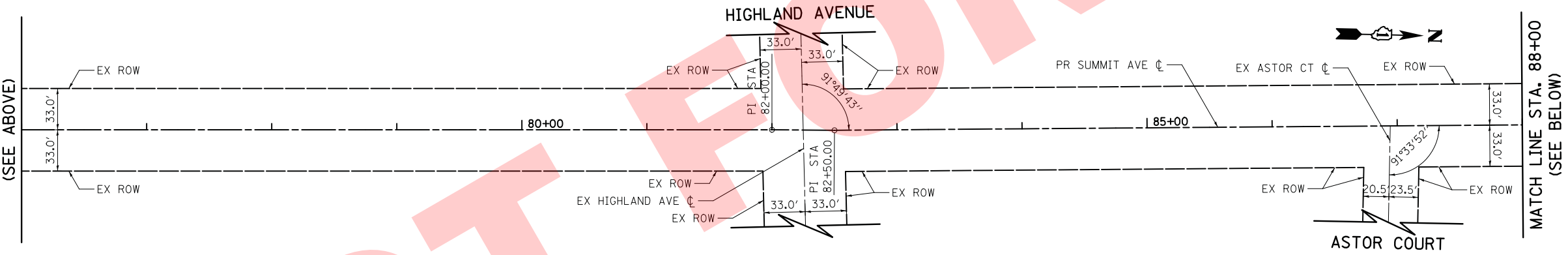
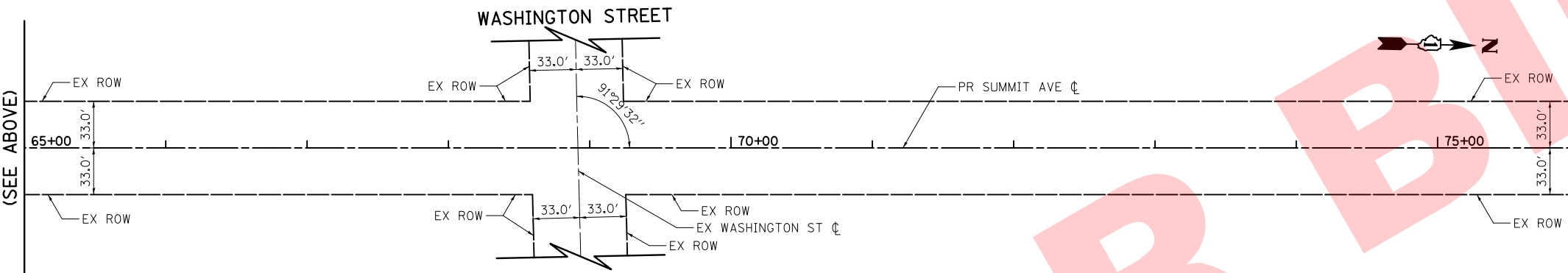
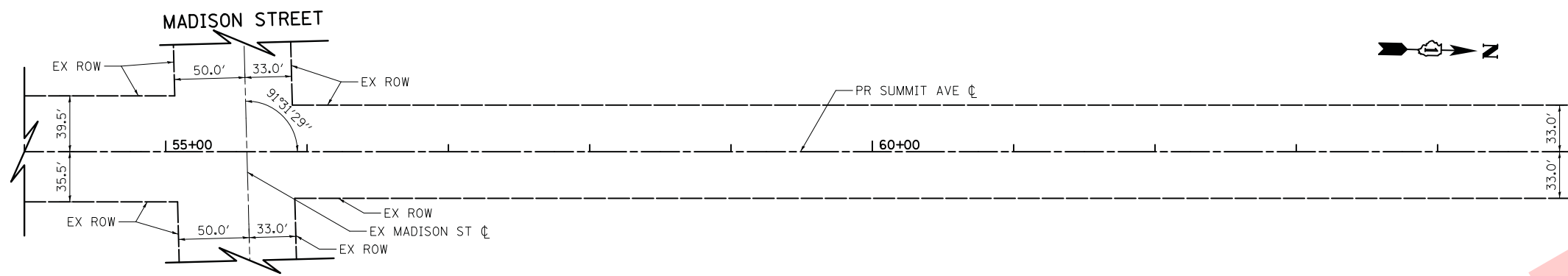

PROPOSED SUMMIT AVENUE CENTERLINE			
DESCRIPTION	STATION	NORTHING	EASTING
B.O.A.	54+00.00	1,897,142.8941	1,082,164.5058
P.I.	82+00.00	1,899,942.1824	1,082,101.3754
P.I.	82+50.00	1,899,992.1770	1,082,100.6433
P.I.	91+21.62	1,900,863.3979	1,082,074.1687
P.I.	91+71.62	1,900,913.3810	1,082,072.8669
E.O.A.	98+25.76	1,901,567.2941	1,082,055.7124

BASIS OF COORDINATES

SUMMIT AVENUE WAS NOT SURVEYED AND DOES NOT HAVE ANY CONTROL POINTS. THE CENTERLINE IS ONLY A BEST-FIT APPROXIMATION REPRESENTING THE CENTER OF ROADWAY AND CENTER OF RIGHT-OF-WAY. AERIAL IMAGERY WAS USED TO CREATE THE CENTERLINE WHICH IS BASED ON THE ILLINOIS STATE PLANE COORDINATE SYSTEM (NAD 83).

BASIS OF ELEVATIONS

SUMMIT AVENUE WAS NOT SURVEYED AND DOES NOT HAVE A BASIS OF ELEVATION OR ANY TEMPORARY BENCHMARKS.

PLOT DRIVER = ...
 PEN TABLE = ...
 FILE NAME = ...



USER NAME = mjp	DESIGNED - MJP	REVISED -
	DRAWN - NEM	REVISED -
PLOT SCALE = 50.0000' / in.	CHECKED - DNM	REVISED -
PLOT DATE = 4/14/2016	DATE - 04/15/16	REVISED -

VILLAGE OF VILLA PARK

**SUMMIT AVENUE
ALIGNMENT, TIES AND BENCHMARKS**

SCALE: 1" = 50' SHEET OF SHEETS STA. TO STA.

F.A. RTE.	SECTION	COUNTY	TOTAL SHEETS	SHEET NO.
		DUPAGE	62	16
CONTRACT NO.				
ILLINOIS FED. AID PROJECT				



PROPOSED WILDFIRE DRIVE CENTERLINE			
DESCRIPTION	STATION	NORTHING	EASTING
B.O.A.	60+00.00	1,908,744.1341	1,079,525.5943
P.I.	64+37.87	1,908,747.3686	1,079,963.4484
P.I.	68+50.70	1,908,763.1683	1,080,375.9766
P.I.	69+00.70	1,908,763.9143	1,080,425.9711
E.O.A.	73+27.09	1,908,776.3949	1,080,852.1793

PROPOSED PRINCETON AVENUE CENTERLINE			
DESCRIPTION	STATION	NORTHING	EASTING
B.O.A.	80+00.00	1,908,349.3845	1,080,412.8261
P.I.	83+89.36	1,908,738.6140	1,080,402.8753
P.I.	84+39.36	1,908,788.4685	1,080,399.0634
E.O.A.	87+50.00	1,909,098.9015	1,080,387.6362

PROPOSED ARDMORE AVENUE CENTERLINE			
DESCRIPTION	STATION	NORTHING	EASTING
B.O.A.	165+00.00	1,908,362.3182	1,080,832.6395
P.C.	167+08.81	1,908,570.1890	1,080,852.4363
P.I.	167+70.58	1,908,631.7726	1,080,858.3013
P.T.	168+32.34	1,908,693.5794	1,080,855.6850
E.O.A.	170+00.00	1,908,861.0879	1,080,848.5941

WILDFIRE DRIVE BENCHMARK AND CONTROL POINT INFORMATION						
BM / CP	STATION	OFFSET	NORTHING	EASTING	ELEVATION	DESCRIPTION
TBM05 CP05	64+70.82	15.11' LT	1,908,763.7277	1,079,995.8007	684.86	SURVEY NAIL IN PAVEMENT AT NORTHEAST CORNER OF YALE AVENUE AND WILDFIRE DRIVE
TBM06 CP06	68+99.81	14.66' RT	1,908,749.2421	1,080,425.2999	682.52	SURVEY NAIL IN PAVEMENT AT THE SOUTHEAST CORNER OF PRINCETON AVENUE AND WILDFIRE DRIVE

BASIS OF COORDINATES

COORDINATES ARE BASED ON THE ILLINOIS STATE PLANE COORDINATE SYSTEM (NAD 83).

BASIS OF ELEVATIONS

DUPAGE COUNTY BENCHMARK NO. YK03001, PID: DK 3101 STATION IS AT THE SOUTHWEST CORNER OF THE INTERSECTION OF NORTH AVENUE (ILLINOIS ROUTE 64) AND VILLA AVENUE. STATION IS 58.6 FEET SOUTH OF THE CENTERLINE OF NORTH AVENUE, 59.3 FEET WEST OF THE CENTERLINE OF VILLA AVENUE, AND 26.5 FEET NORTHWEST OF A FIRE HYDRANT. MONUMENT IS 1.2 FEET ABOVE ROAD SURFACE ON A 2.5 FOOT DIAMETER CONCRETE TRAFFIC SIGNAL BASE AND IS FERRO MAGNETIC. ELEVATION 679.61 N.G.V.D. 1988 DATUM.

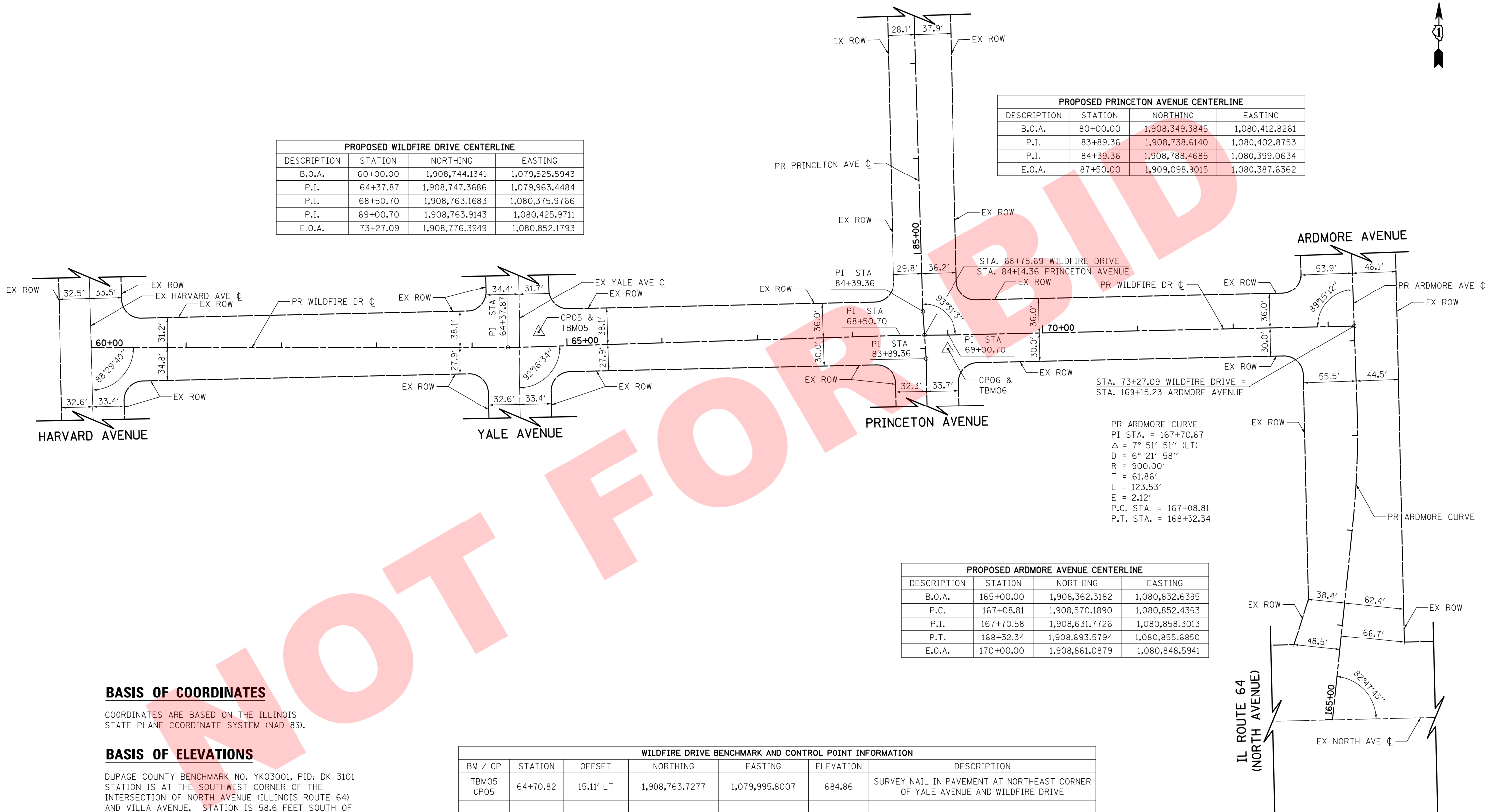

PR ARDMORE CURVE
 PI STA. = 167+70.67
 $\Delta = 7^\circ 51' 51''$ (LT)
 $D = 6^\circ 21' 58''$
 $R = 900.00'$
 $T = 61.86'$
 $L = 123.53'$
 $E = 2.12'$
 P.C. STA. = 167+08.81
 P.T. STA. = 168+32.34

PLOT DRIVER = ...
 PEN TABLE = ...
 FILE NAME = ...



USER NAME = mjp	DESIGNED - MJP	REVISED -
PLOT SCALE = 50.0000' / in.	DRAWN - NEM	REVISED -
PLOT DATE = 4/14/2016	CHECKED - DNM	REVISED -
	DATE - 04/15/16	REVISED -

VILLAGE OF VILLA PARK

**WILDFIRE DRIVE, PRINCETON AVENUE, AND ARDMORE AVENUE
ALIGNMENT, TIES AND BENCHMARKS**

SCALE: 1" = 50' SHEET OF SHEETS STA. TO STA.

F.A. RTE.	SECTION	COUNTY	TOTAL SHEETS	SHEET NO.
		DUPAGE	62	17
CONTRACT NO.				
ILLINOIS FED. AID PROJECT				

PLAN	SURVEYED	DATE
	PLOTTED	BY
	CHECKED	
	AT	
	NO.	

PROFILE	SURVEYED	DATE
	PLOTTED	BY
	CHECKED	
	AT	
	NO.	

PLOT DRIVER = ...mjp\vdms09314\csl.paf.plt
 PLOT NAME = ...s\p16\csl\csl.paf.plt
 FILE NAME = ...388P-111-111-111.dwg

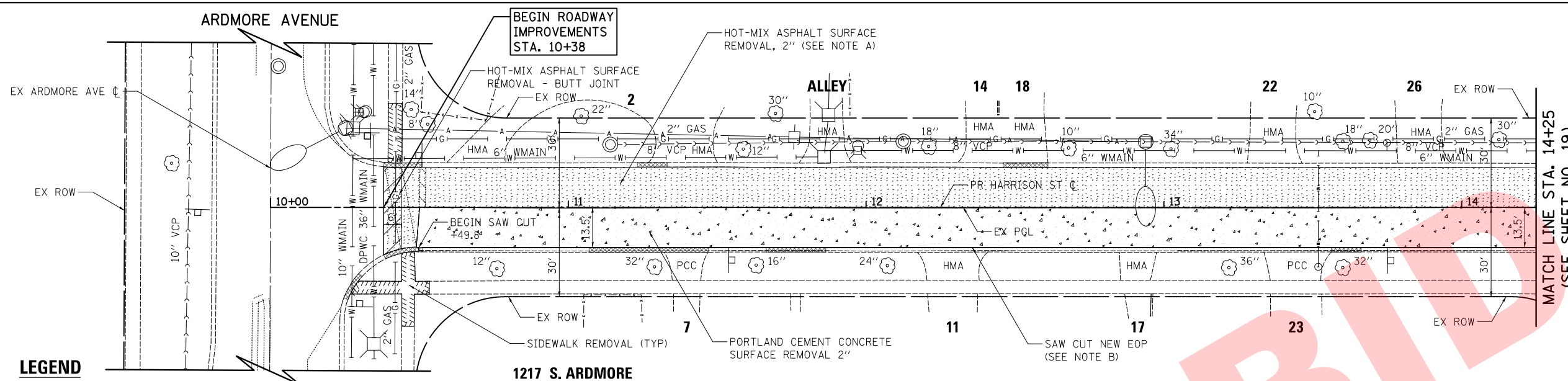

LEGEND

- HOUSE NUMBER

NOTES

- A. THE REMOVAL OF HMA SURFACE SHALL BE PAID FOR AS: HOT-MIX ASPHALT SURFACE REMOVAL, VARIABLE DEPTH
- B. THE SAW CUT SHALL BE FULL DEPTH AND WILL BE PAID FOR AS: SAWING P.C. CONCRETE PAVEMENT (FULL DEPTH)

HARRISON STREET - REMOVAL PLAN

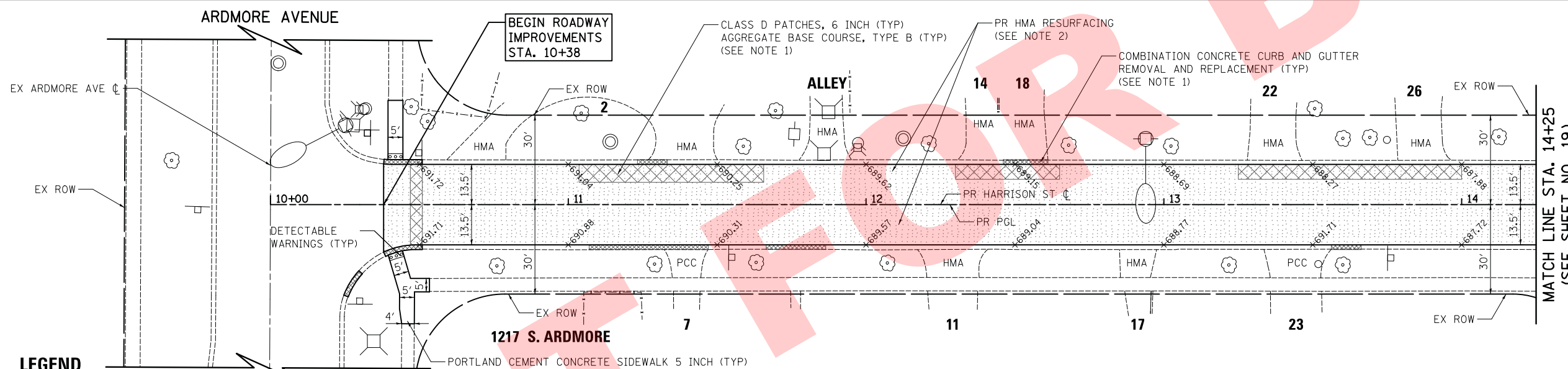

LEGEND

- HOUSE NUMBER

NOTES

- 1. THE LOCATIONS AND DIMENSIONS OF ALL PAVEMENT PATCHING AND CURB AND GUTTER REPLACEMENT SHALL BE DETERMINED BY THE ENGINEER IN THE FIELD. FOR ADDITIONAL DETAILS, SEE CONSTRUCTION SEQUENCE NOTES AND OTHER RELEVANT NOTES IN THE MAINTENANCE OF TRAFFIC AND GENERAL NOTES.
- 2. PR HMA RESURFACING:
 -HOT-MIX ASPHALT SURFACE COURSE, MIX "D", N50, 1 1/2"
 -LEVELING BINDER (MACHINE METHOD), N50, 3/4"

HARRISON STREET - PROPOSED PLAN

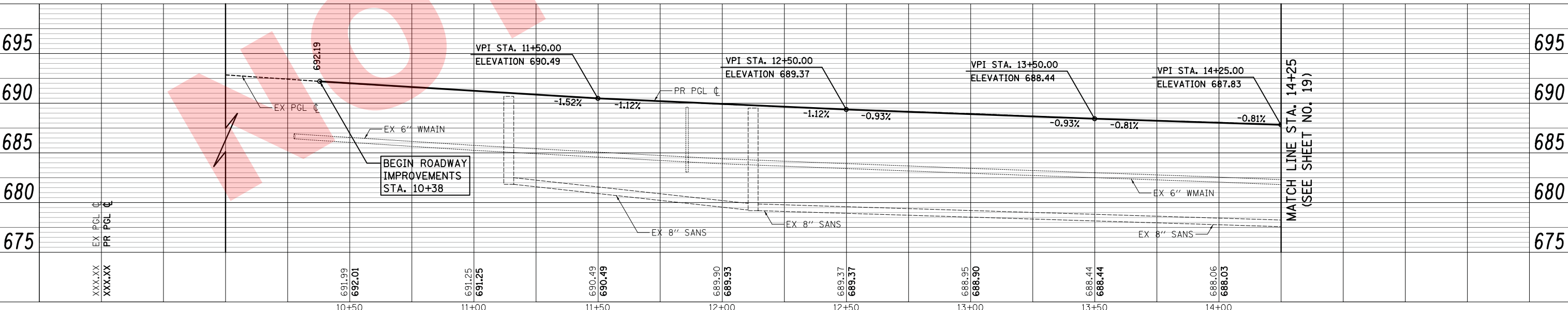

USER NAME = mjp	DESIGNED - MJP	REVISED -
	DRAWN - NEM	REVISED -
PLOT SCALE = 20.0000' / in.	CHECKED - DNM	REVISED -
PLOT DATE = 4/14/2016	DATE - 04/15/16	REVISED -

VILLAGE OF VILLA PARK

HARRISON STREET
 ROADWAY REMOVAL, PROPOSED PLAN AND PROFILE

SCALE: 1" = 20' SHEET OF SHEETS STA. 10+38 TO STA. 14+25

F.A. RTE.	SECTION	COUNTY	TOTAL SHEETS	SHEET NO.
		DUPAGE	62	18
CONTRACT NO.				
ILLINOIS FED. AID PROJECT				

LEGEND

- HOUSE NUMBER

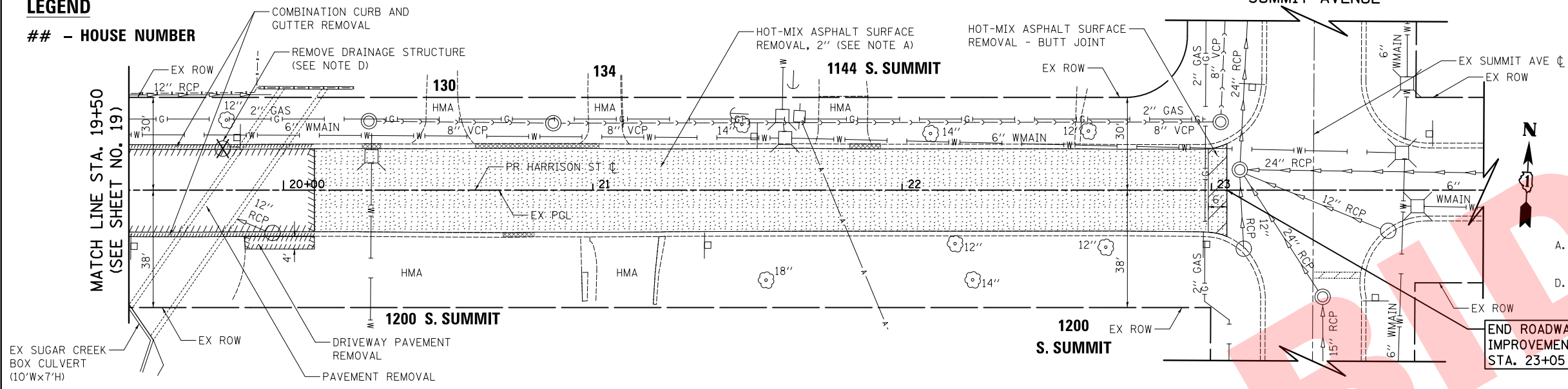

HARRISON STREET CROSS-SLOPE TRANSITION TABLE				
EASTBOUND MOVEMENT				
STATION	PGL ELEVATION	CROSS SLOPE	WIDTH FROM PGL TO EOP (RT)	EOP ELEVATION (RT OF PGL)
18+55.0	672.89	-2.00%	13.5	672.62
19+45.0	671.12	-2.00%	13.5	670.85
19+60.0	671.06	-2.50%	13.5	670.72
19+75.0	671.06	-2.00%	13.5	670.79
19+80.0	671.08	-2.00%	13.5	670.81
20+10.0	671.32	-1.00%	13.5	671.18

- NOTES**
- A. THE REMOVAL OF HMA SURFACE SHALL BE PAID FOR AS: HOT-MIX ASPHALT SURFACE REMOVAL, VARIABLE DEPTH
 - D. DRAINAGE STRUCTURE REMOVAL AND STORM SEWER REMOVAL SHALL BE INCLUDED IN THE COST OF THE PROPOSED DRAINAGE ITEMS BEING INSTALLED.

HARRISON STREET - REMOVAL PLAN

LEGEND

- HOUSE NUMBER

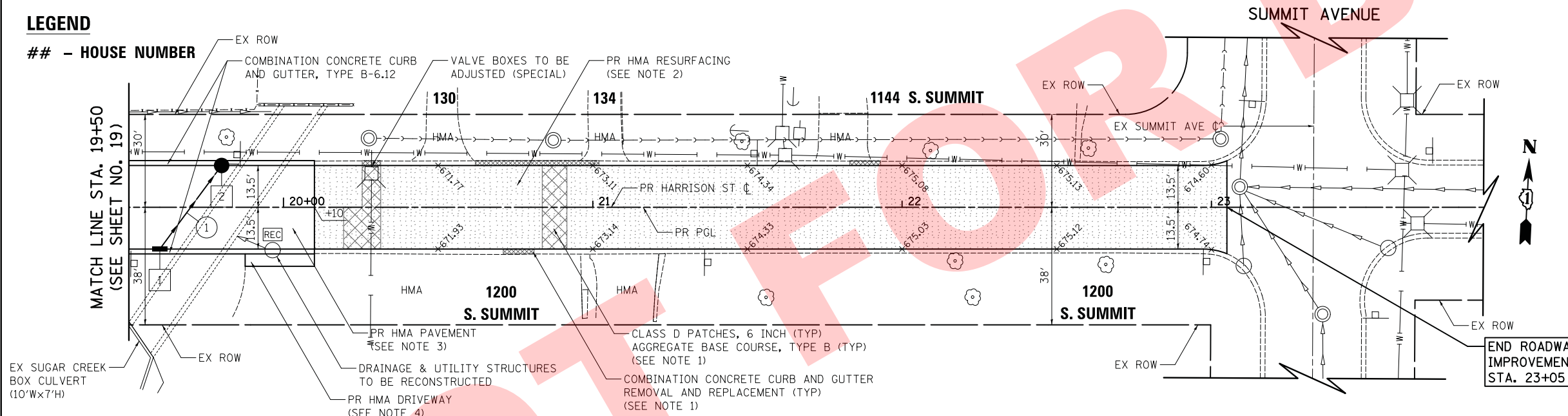

HARRISON STREET CROSS-SLOPE TRANSITION TABLE				
WESTBOUND MOVEMENT				
STATION	PGL ELEVATION	CROSS SLOPE	WIDTH FROM PGL TO EOP (LT)	EOP ELEVATION (LT OF PGL)
18+55.0	672.89	-2.00%	13.5	672.62
18+77.3	672.23	*	35.5	672.43
18+89.8	671.92	*	35.5	672.56
19+02.3	671.66	*	35.5	672.47
19+25.0	671.31	-2.00%	13.5	671.04
19+50.0	671.07	-2.00%	13.5	670.80
19+80.0	671.08	-3.00%	13.5	670.67
20+10.0	671.32	-2.50%	13.5	670.98

*CROSS-SLOPES ARE SHOWN ON PROPOSED PLAN AT THE INTERSECTION OF HARRISON STREET AND CORNELL AVENUE

- 1 STA 19+60.0, 13.5' RT INLETS TA T11F&G RIM = 670.72 INV = 668.47 (10" NE)
- 2 STA 19+80.0, 13.5' LT CB TC T11F&G RIM = 670.67 INV = 668.13 (10" SW) INV = 668.03 (EX 12" E)

① 34" - STORM SEW CL A 1, 10' @ 1.00% T.B.F. = 4.7 CU YD

NOTES

- THE LOCATIONS AND DIMENSIONS OF ALL PAVEMENT PATCHING AND CURB AND GUTTER REPLACEMENT SHALL BE DETERMINED BY THE ENGINEER IN THE FIELD. FOR ADDITIONAL DETAILS, SEE CONSTRUCTION SEQUENCE NOTES AND OTHER RELEVANT NOTES IN THE MAINTENANCE OF TRAFFIC AND GENERAL NOTES.
- PR HMA RESURFACING:
-HOT-MIX ASPHALT SURFACE COURSE, MIX "D", N50, 1 1/2"
-LEVELING BINDER (MACHINE METHOD), N50, 3/4"
- PR HMA PAVEMENT:
-HOT-MIX ASPHALT SURFACE COURSE, MIX "D", N50, 2"
-HOT-MIX ASPHALT BINDER COURSE, IL-19.0, N50, 4"
-AGGREGATE BASE COURSE, TYPE B 8"
-GEOGRID
- PR HMA DRIVEWAY:
-HOT-MIX ASPHALT DRIVEWAY PAVEMENT, 4"
-AGGREGATE BASE COURSE, TYPE B 6"

HARRISON STREET - PROPOSED PLAN

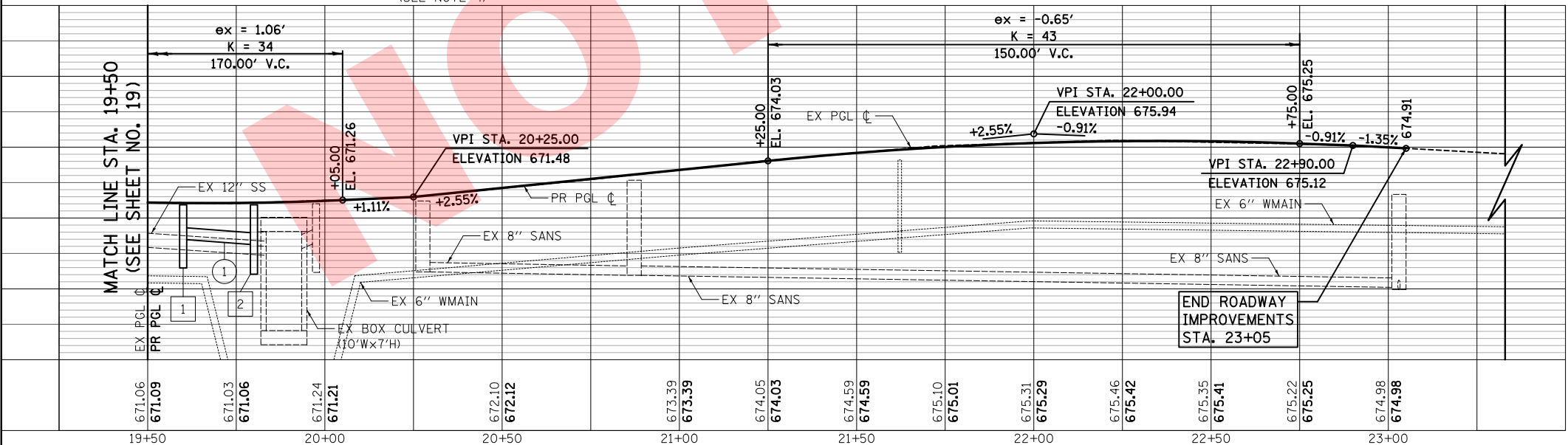

DATE	BY	DATE	BY
PLAN	SURVEYED	CHECKED	NO.

DATE	BY	DATE	BY
PROFILE	SURVEYED	CHECKED	NO.

PLOT DRIVER = ...
PLOT FILE = ...
FILE NAME = ...



USER NAME = mjp	DESIGNED - MJP	REVISED -
PLOT SCALE = 20.0000' / in.	DRAWN - NEM	REVISED -
PLOT DATE = 4/14/2016	CHECKED - DNM	REVISED -
	DATE - 04/15/16	REVISED -

VILLAGE OF VILLA PARK

HARRISON STREET			
ROADWAY REMOVAL, PROPOSED PLAN AND PROFILE			
SCALE: 1" = 20'	SHEET	OF SHEETS	STA. 19+50 TO STA. 23+05

F.A. RTE.	SECTION	COUNTY	TOTAL SHEETS	SHEET NO.
		DUPAGE	62	20
CONTRACT NO.				
ILLINOIS FED. AID PROJECT				

NOTES

B. THE SAW CUT SHALL BE FULL DEPTH AND WILL BE PAID FOR AS: SAWING P.C. CONCRETE PAVEMENT (FULL DEPTH)

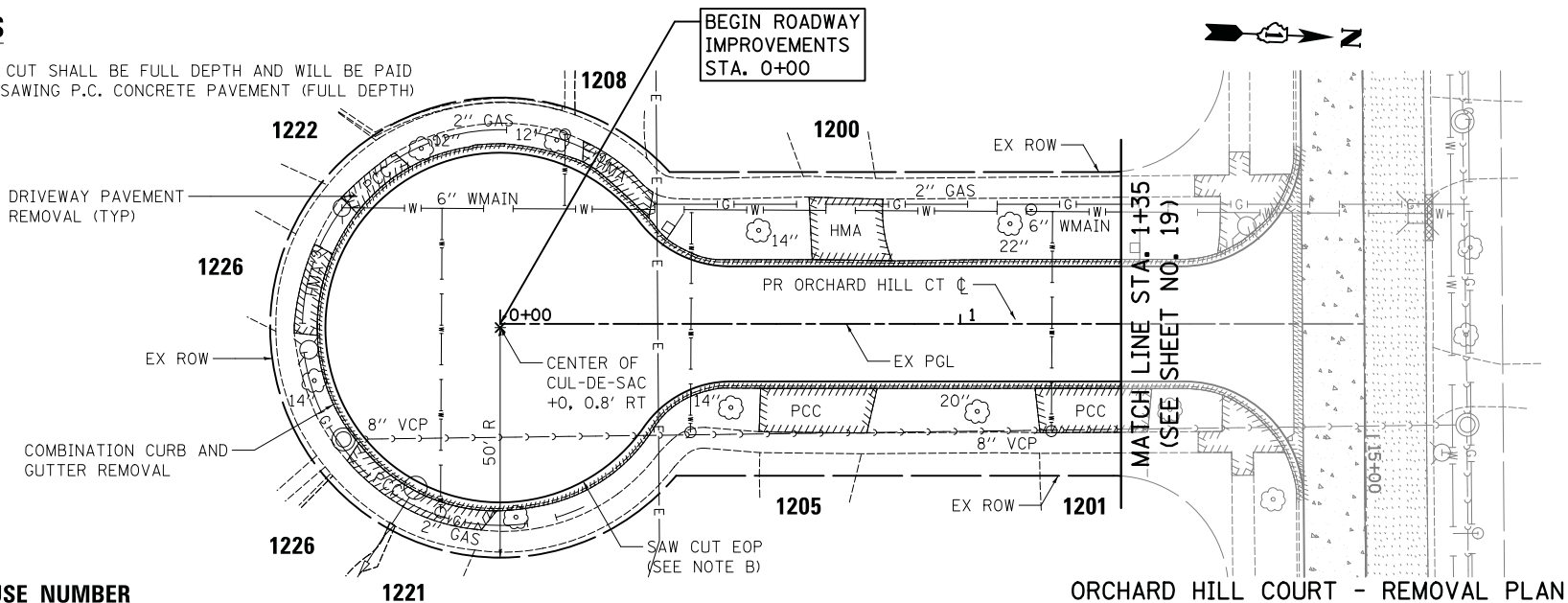

LEGEND

- HOUSE NUMBER

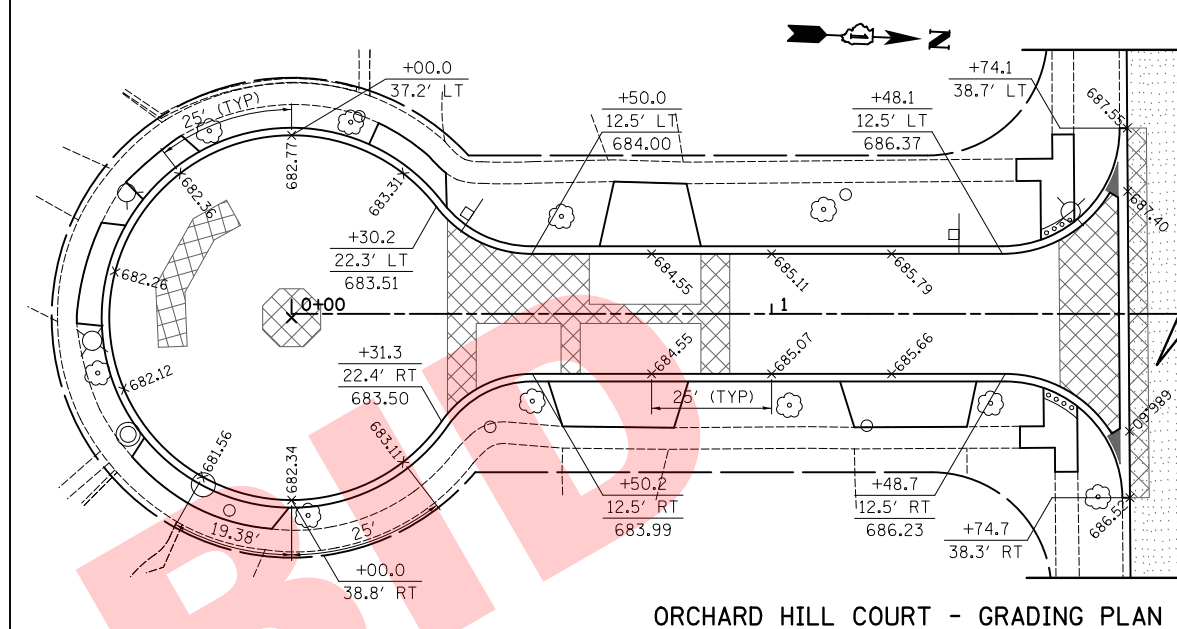

ORCHARD HILL COURT - GRADING PLAN

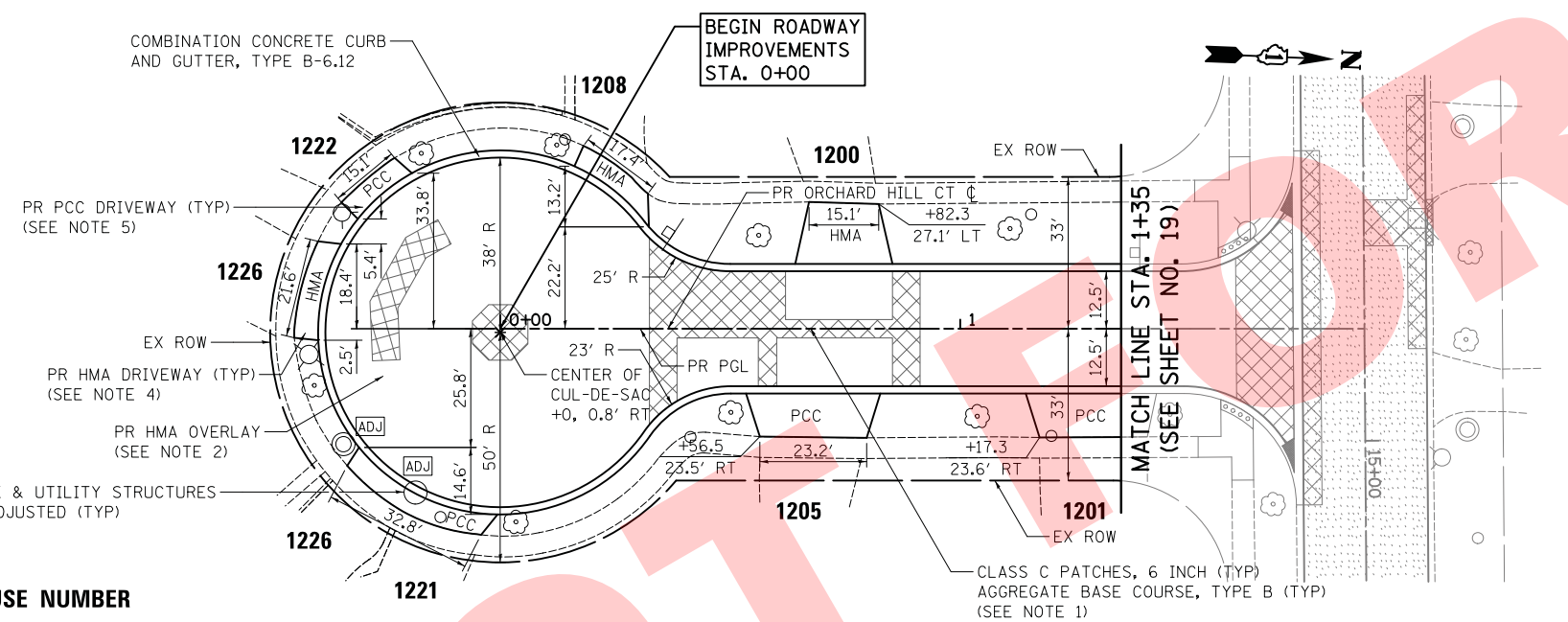

LEGEND

- HOUSE NUMBER

NOTES

1. THE LOCATIONS AND DIMENSIONS OF ALL PAVEMENT PATCHING SHALL BE DETERMINED BY THE ENGINEER IN THE FIELD. FOR ADDITIONAL DETAILS, SEE CONSTRUCTION SEQUENCE NOTES AND OTHER RELEVANT NOTES IN THE MAINTENANCE OF TRAFFIC AND GENERAL NOTES.
2. PR HMA OVERLAY:
-HOT-MIX ASPHALT SURFACE COURSE, MIX "D", N50, 1 1/2"
-LEVELING BINDER (MACHINE METHOD), N50, 3/4"
4. PR HMA DRIVEWAY:
-HOT-MIX ASPHALT DRIVEWAY PAVEMENT, 4"
-AGGREGATE BASE COURSE, TYPE B 6"
5. PR PCC DRIVEWAY:
-PORTLAND CEMENT CONCRETE DRIVEWAY PAVEMENT, 6 INCH
-AGGREGATE BASE COURSE, TYPE B 4"

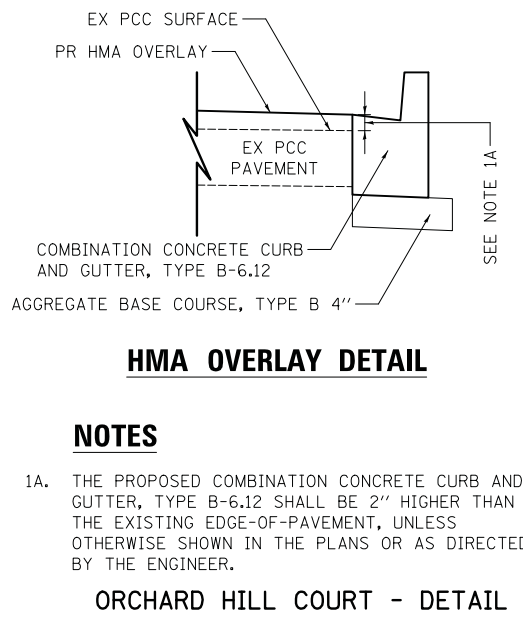

HMA OVERLAY DETAIL

NOTES

- 1A. THE PROPOSED COMBINATION CONCRETE CURB AND GUTTER, TYPE B-6.12 SHALL BE 2" HIGHER THAN THE EXISTING EDGE-OF-PAVEMENT, UNLESS OTHERWISE SHOWN IN THE PLANS OR AS DIRECTED BY THE ENGINEER.

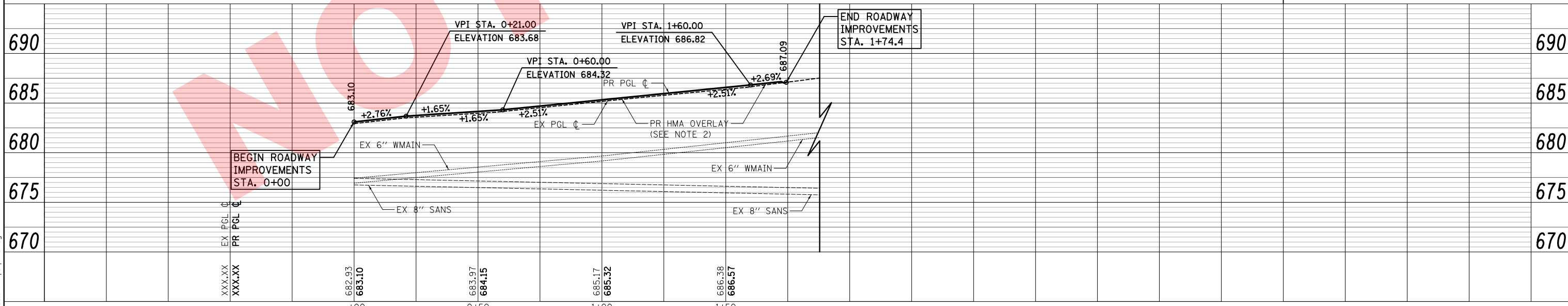

PLAN	SURVEYED	DATE
	PLOTTED	
	CHECKED	
	NOTED	
	NO. 1	

PROFILE	SURVEYED	DATE
	PLOTTED	
	CHECKED	
	NOTED	
	NO. 1	

PLOT DRIVER = ...
PLOT FILE = ...
FILE NAME = ...



USER NAME = mjp	DESIGNED - MJP	REVISED -
PLOT SCALE = 20.0000' / 1"	DRAWN - NEM	REVISED -
PLOT DATE = 4/14/2016	CHECKED - DNM	REVISED -
	DATE - 04/15/16	REVISED -

VILLAGE OF VILLA PARK

**ORCHARD HILL COURT
ROADWAY REMOVAL, PROPOSED PLAN AND PROFILE**

SCALE: 1" = 20' SHEET OF SHEETS STA. 0+00 TO STA. 1+35

F.A. RTE.	SECTION	COUNTY	TOTAL SHEETS	SHEET NO.
		DUPAGE	62	21
CONTRACT NO.				
ILLINOIS FED. AID PROJECT				

PLAN	SURVEYED	DATE
	PLOTTED	BY
	CHECKED	
	ALIGNED	
	FILE NAME	

PROFILE	SURVEYED	DATE
	PLOTTED	BY
	CHECKED	
	ALIGNED	
	FILE NAME	

PLOT DRIVER = ...
 PLOT SCALE = 20.0000' / 1" = ...
 FILE NAME = ...

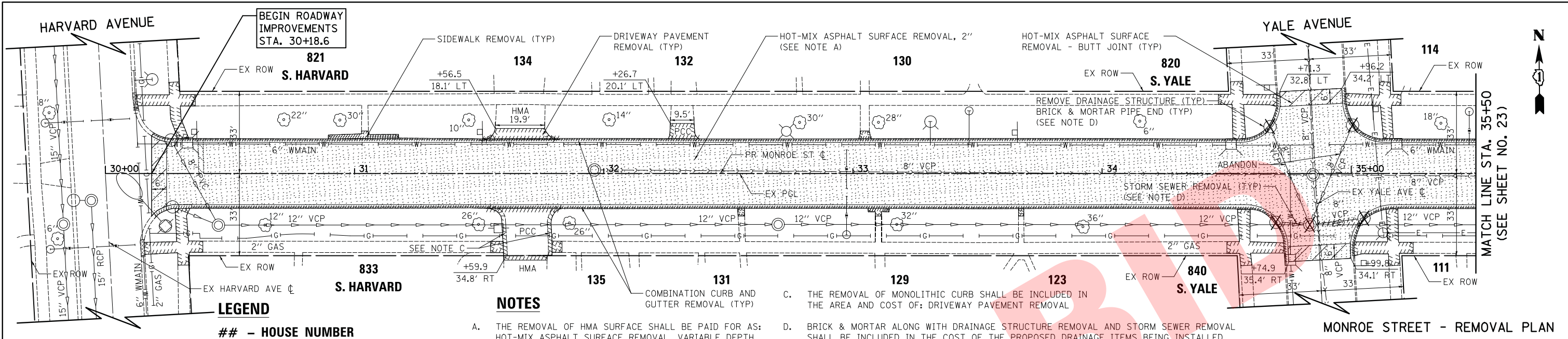

- NOTES**
- A. THE REMOVAL OF HMA SURFACE SHALL BE PAID FOR AS: HOT-MIX ASPHALT SURFACE REMOVAL, VARIABLE DEPTH
 - B. THE REMOVAL OF MONOLITHIC CURB SHALL BE INCLUDED IN THE AREA AND COST OF: DRIVEWAY PAVEMENT REMOVAL
 - C. THE REMOVAL OF MONOLITHIC CURB SHALL BE INCLUDED IN THE AREA AND COST OF: DRIVEWAY PAVEMENT REMOVAL
 - D. BRICK & MORTAR ALONG WITH DRAINAGE STRUCTURE REMOVAL AND STORM SEWER REMOVAL SHALL BE INCLUDED IN THE COST OF THE PROPOSED DRAINAGE ITEMS BEING INSTALLED.

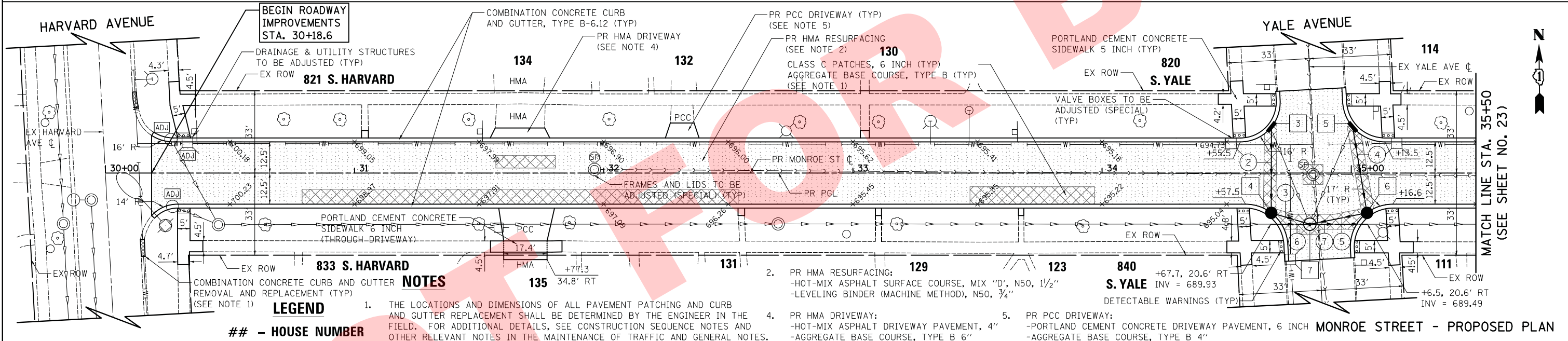

- NOTES**
- 1. THE LOCATIONS AND DIMENSIONS OF ALL PAVEMENT PATCHING AND CURB AND GUTTER REPLACEMENT SHALL BE DETERMINED BY THE ENGINEER IN THE FIELD. FOR ADDITIONAL DETAILS, SEE CONSTRUCTION SEQUENCE NOTES AND OTHER RELEVANT NOTES IN THE MAINTENANCE OF TRAFFIC AND GENERAL NOTES.
 - 2. PR HMA RESURFACING:
 - HOT-MIX ASPHALT SURFACE COURSE, MIX "D", N50, 1/2"
 - LEVELING BINDER (MACHINE METHOD), N50, 3/4"
 - 3. PR HMA DRIVEWAY:
 - HOT-MIX ASPHALT DRIVEWAY PAVEMENT, 4"
 - AGGREGATE BASE COURSE, TYPE B 6"
 - 4. PR PCC DRIVEWAY:
 - PORTLAND CEMENT CONCRETE DRIVEWAY PAVEMENT, 6 INCH
 - AGGREGATE BASE COURSE, TYPE B 4"

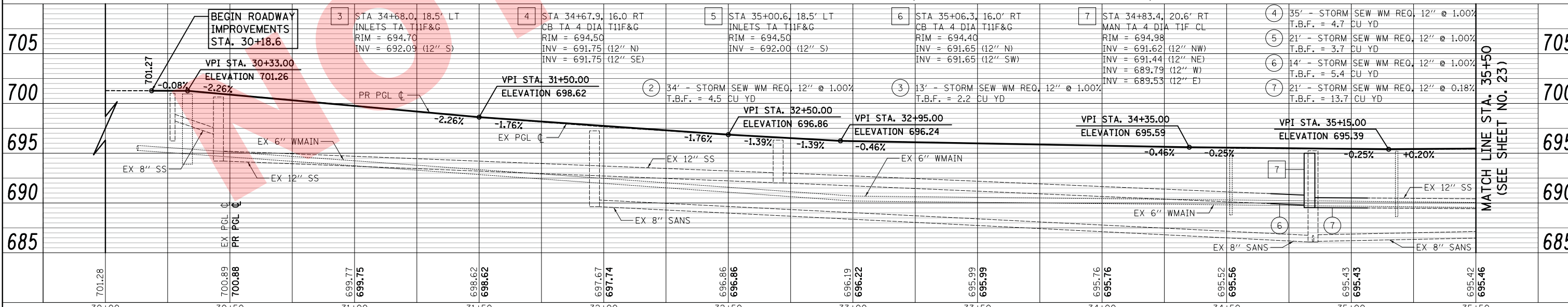

USER NAME = m_jp	DESIGNED - MJP	REVISED -	MONROE STREET	
PLOT SCALE = 20.0000' / 1"	DRAWN - NEM	REVISED -	ROADWAY REMOVAL, PROPOSED PLAN AND PROFILE	
PLOT DATE = 4/14/2016	CHECKED - DNM	REVISED -	SCALE: 1" = 20'	SHEET OF SHEETS STA. 30+18.6 TO STA. 35+50
	DATE - 04/15/16	REVISED -	SECTION COUNTY COUNTY TOTAL SHEETS SHEET NO.	
			ILLINOIS FED. AID PROJECT	

PLAN	SURVEYED	DATE
	PLOTTED	BY
	CHECKED	
	NO. 1	
	NO. 2	
	NO. 3	
	NO. 4	
	NO. 5	
	NO. 6	
	NO. 7	
	NO. 8	
	NO. 9	
	NO. 10	

PROFILE	SURVEYED	DATE
	PLOTTED	BY
	CHECKED	
	NO. 1	
	NO. 2	
	NO. 3	
	NO. 4	
	NO. 5	
	NO. 6	
	NO. 7	
	NO. 8	
	NO. 9	
	NO. 10	

PLOT DRIVER = ...mup\dm00314\...
 PLOT FILE = ...
 FILE NAME = ...

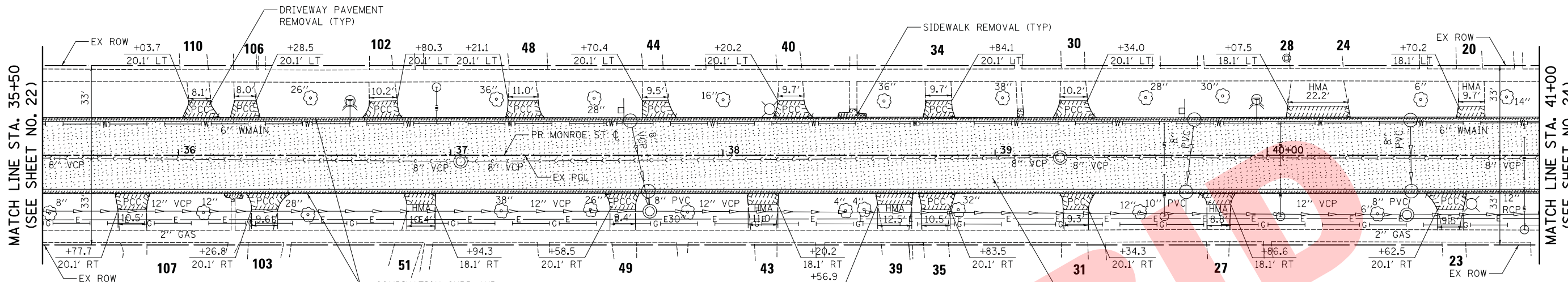

LEGEND

- HOUSE NUMBER

NOTES

A. THE REMOVAL OF HMA SURFACE SHALL BE PAID FOR AS:
 HOT-MIX ASPHALT SURFACE REMOVAL, VARIABLE DEPTH

MONROE STREET - REMOVAL PLAN

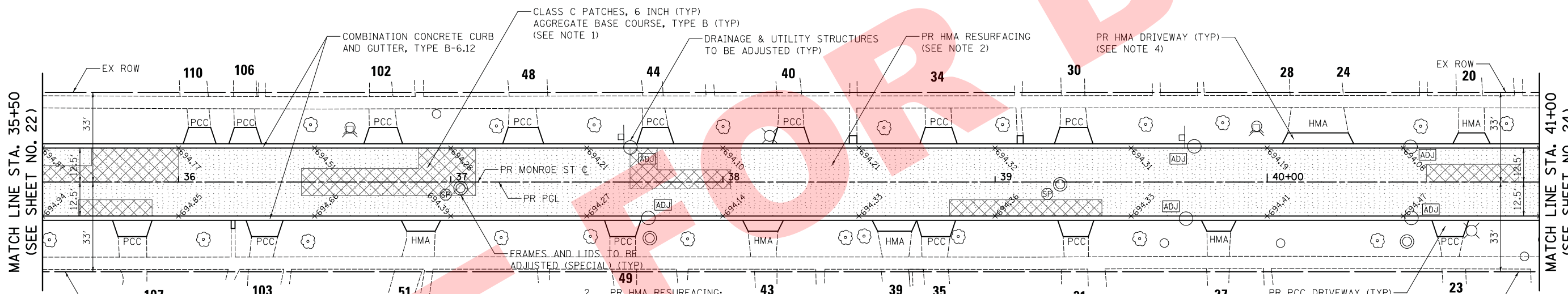

LEGEND

- HOUSE NUMBER

1. THE LOCATIONS AND DIMENSIONS OF ALL PAVEMENT PATCHING SHALL BE DETERMINED BY THE ENGINEER IN THE FIELD. FOR ADDITIONAL DETAILS, SEE CONSTRUCTION SEQUENCE NOTES AND OTHER RELEVANT NOTES IN THE MAINTENANCE OF TRAFFIC AND GENERAL NOTES.

2. PR HMA RESURFACING:
 -HOT-MIX ASPHALT SURFACE COURSE, MIX "D", N50, 1 1/2"
 -LEVELING BINDER (MACHINE METHOD), N50, 3/4"

4. PR HMA DRIVEWAY:
 -HOT-MIX ASPHALT DRIVEWAY PAVEMENT, 4"
 -AGGREGATE BASE COURSE, TYPE B 6"

5. PR PCC DRIVEWAY:
 -PORTLAND CEMENT CONCRETE DRIVEWAY PAVEMENT, 6 INCH
 -AGGREGATE BASE COURSE, TYPE B 4"

MONROE STREET - PROPOSED PLAN

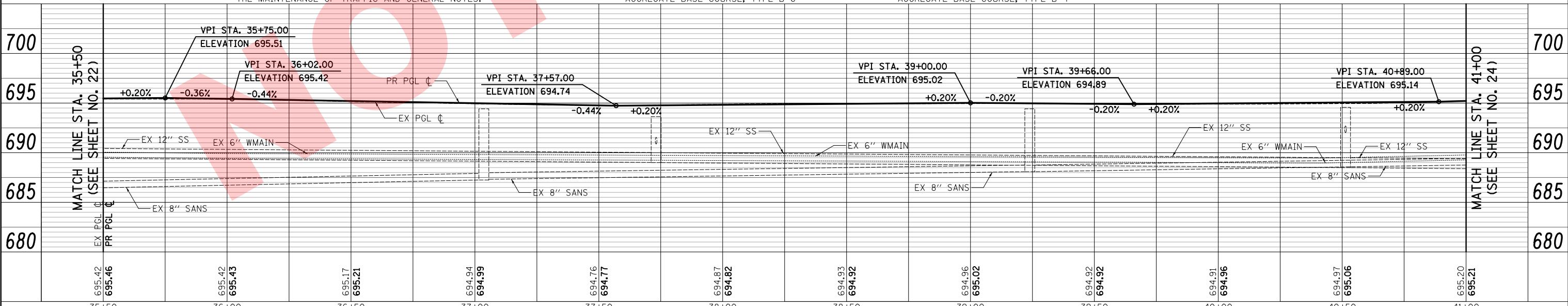

USER NAME = mjp	DESIGNED - MJP	REVISED -
	DRAWN - NEM	REVISED -
PLOT SCALE = 20.0000' / in.	CHECKED - DNM	REVISED -
PLOT DATE = 4/14/2016	DATE - 04/15/16	REVISED -

VILLAGE OF VILLA PARK

**MONROE STREET
 ROADWAY REMOVAL, PROPOSED PLAN AND PROFILE**

SCALE: 1" = 20' SHEET OF SHEETS STA. 35+50 TO STA. 41+00

F.A. RTE.	SECTION	COUNTY	TOTAL SHEETS	SHEET NO.
		DUPAGE	62	23
CONTRACT NO.				
ILLINOIS FED. AID PROJECT				

PLAN	SURVEYED	DATE
	PLOTTED	BY
	CHECKED	
	ALIGNED	
	FILE NAME	
	NO.	

PROFILE	SURVEYED	DATE
	GRADES CHECKED	BY
	STRUCTURE NOTATIONS OK'D	
	NO.	

PLOT DRIVER = ...mup\dm0314\cor_paf.plt
 PLOT FILE = ...9601\cor_tdr\pdrudtbl
 FILE NAME = ...395P-nt-pdrudtbl

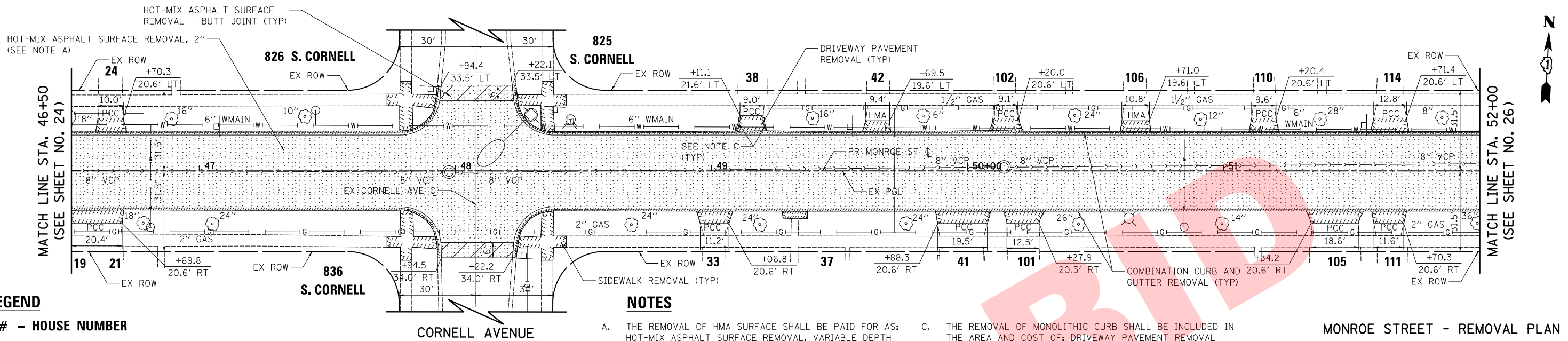

LEGEND

- HOUSE NUMBER

NOTES

- A. THE REMOVAL OF HMA SURFACE SHALL BE PAID FOR AS: HOT-MIX ASPHALT SURFACE REMOVAL, VARIABLE DEPTH
- C. THE REMOVAL OF MONOLITHIC CURB SHALL BE INCLUDED IN THE AREA AND COST OF: DRIVEWAY PAVEMENT REMOVAL

MONROE STREET - REMOVAL PLAN

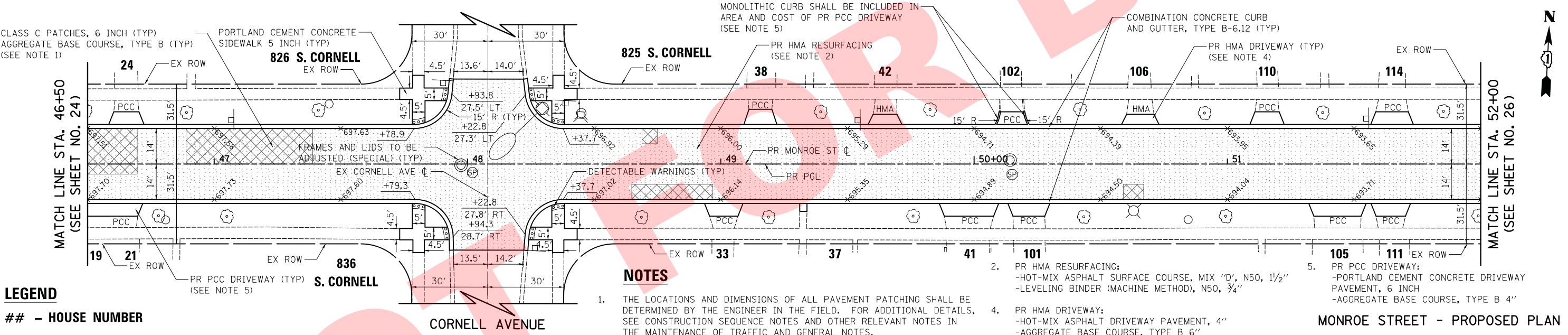

LEGEND

- HOUSE NUMBER

NOTES

- 1. THE LOCATIONS AND DIMENSIONS OF ALL PAVEMENT PATCHING SHALL BE DETERMINED BY THE ENGINEER IN THE FIELD. FOR ADDITIONAL DETAILS, SEE CONSTRUCTION SEQUENCE NOTES AND OTHER RELEVANT NOTES IN THE MAINTENANCE OF TRAFFIC AND GENERAL NOTES.
- 2. PR HMA RESURFACING: -HOT-MIX ASPHALT SURFACE COURSE, MIX "D", N50, 1 1/2" -LEVELING BINDER (MACHINE METHOD), N50, 3/4"
- 4. PR HMA DRIVEWAY: -HOT-MIX ASPHALT DRIVEWAY PAVEMENT, 4" -AGGREGATE BASE COURSE, TYPE B 6"
- 5. PR PCC DRIVEWAY: -PORTLAND CEMENT CONCRETE DRIVEWAY PAVEMENT, 6 INCH -AGGREGATE BASE COURSE, TYPE B 4"

MONROE STREET - PROPOSED PLAN

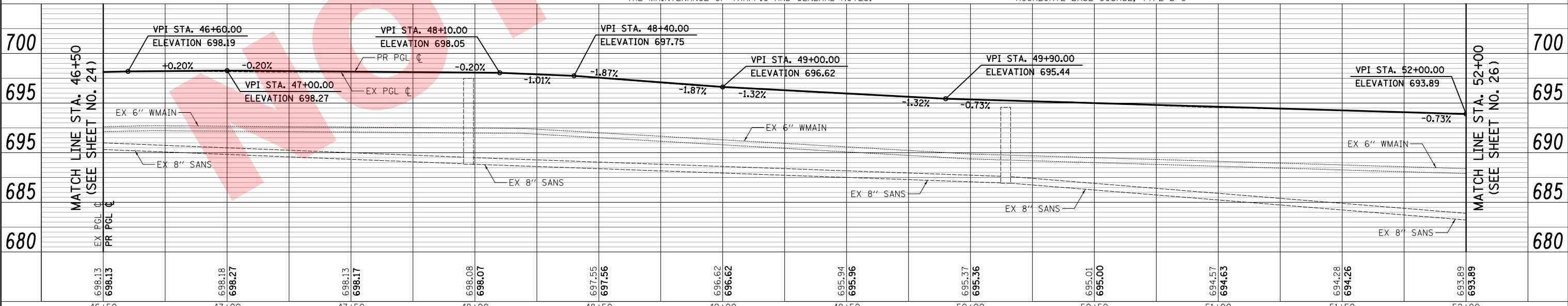

USER NAME = mjp DESIGNED - MJP DRAWN - NEM CHECKED - DNM PLOT DATE = 4/14/2016	REVISED - REVISED - REVISED - REVISED -	MONROE STREET ROADWAY REMOVAL, PROPOSED PLAN AND PROFILE		SECTION	COUNTY	TOTAL SHEETS	SHEET NO.
					DUPAGE	62	25
SCALE: 1" = 20' SHEET OF SHEETS STA. 46+50 TO STA. 52+00				CONTRACT NO.			



VILLAGE OF VILLA PARK

ILLINOIS FED. AID PROJECT

PLAN	SURVEYED	DATE
	PLOTTED	BY
	CHECKED	
	ALIGNED	
	FILED	
	NO.	

PROFILE	SURVEYED	DATE
	PLOTTED	BY
	CHECKED	
	ALIGNED	
	FILED	
	NO.	

PLOT DRIVER = ...
 PLOT FILE = ...
 FILE NAME = ...

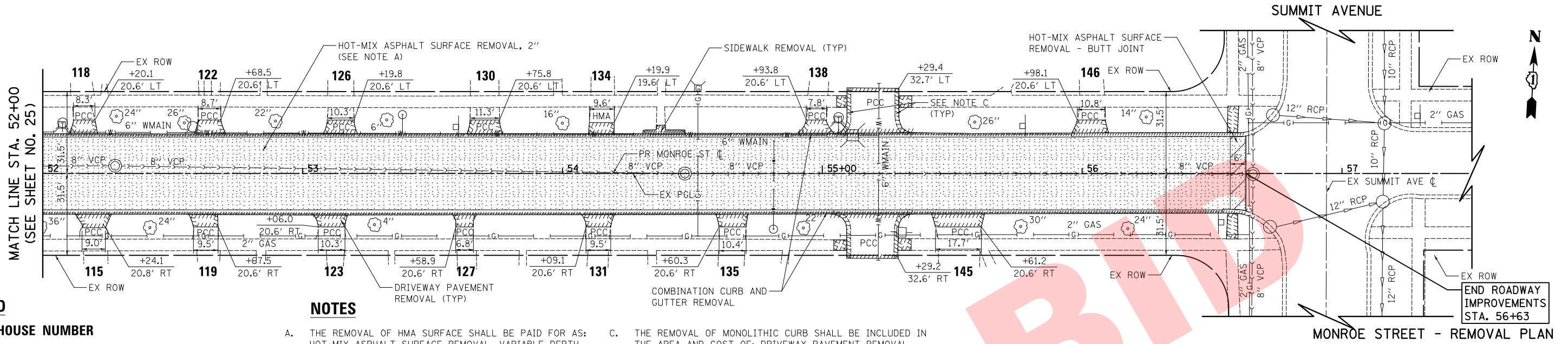

LEGEND

- HOUSE NUMBER

NOTES

- A. THE REMOVAL OF HMA SURFACE SHALL BE PAID FOR AS: HOT-MIX ASPHALT SURFACE REMOVAL, VARIABLE DEPTH
- C. THE REMOVAL OF MONOLITHIC CURB SHALL BE INCLUDED IN THE AREA AND COST OF: DRIVEWAY PAVEMENT REMOVAL

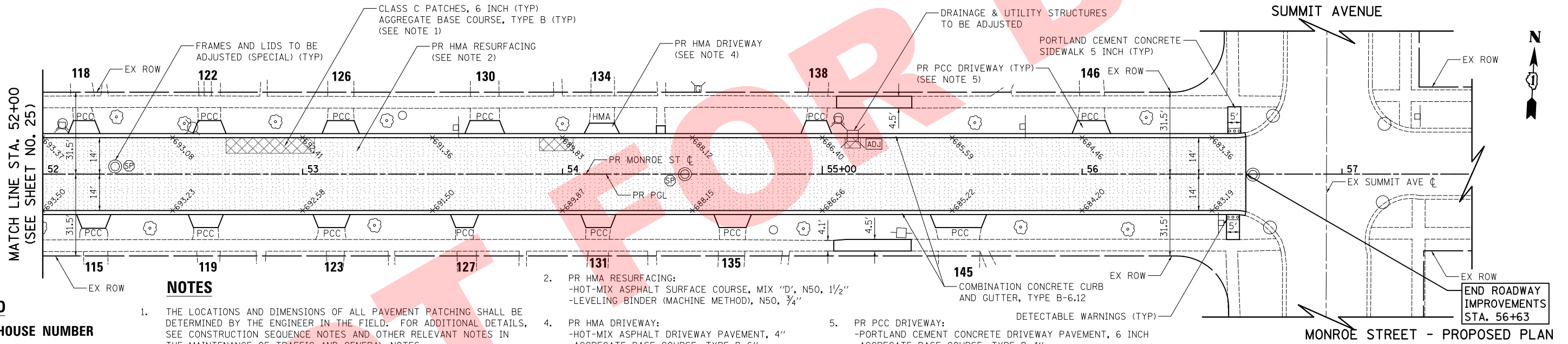

LEGEND

- HOUSE NUMBER

- 1. THE LOCATIONS AND DIMENSIONS OF ALL PAVEMENT PATCHING SHALL BE DETERMINED BY THE ENGINEER IN THE FIELD. FOR ADDITIONAL DETAILS, SEE CONSTRUCTION SEQUENCE NOTES AND OTHER RELEVANT NOTES IN THE MAINTENANCE OF TRAFFIC AND GENERAL NOTES.
- 2. PR HMA RESURFACING:
 -HOT-MIX ASPHALT SURFACE COURSE, MIX "D", N50, 1 1/2"
 -LEVELING BINDER (MACHINE METHOD), N50, 3/4"
- 4. PR HMA DRIVEWAY:
 -HOT-MIX ASPHALT DRIVEWAY PAVEMENT, 4"
 -AGGREGATE BASE COURSE, TYPE B 6"
- 5. PR PCC DRIVEWAY:
 -PORTLAND CEMENT CONCRETE DRIVEWAY PAVEMENT, 6 INCH
 -AGGREGATE BASE COURSE, TYPE B 4"

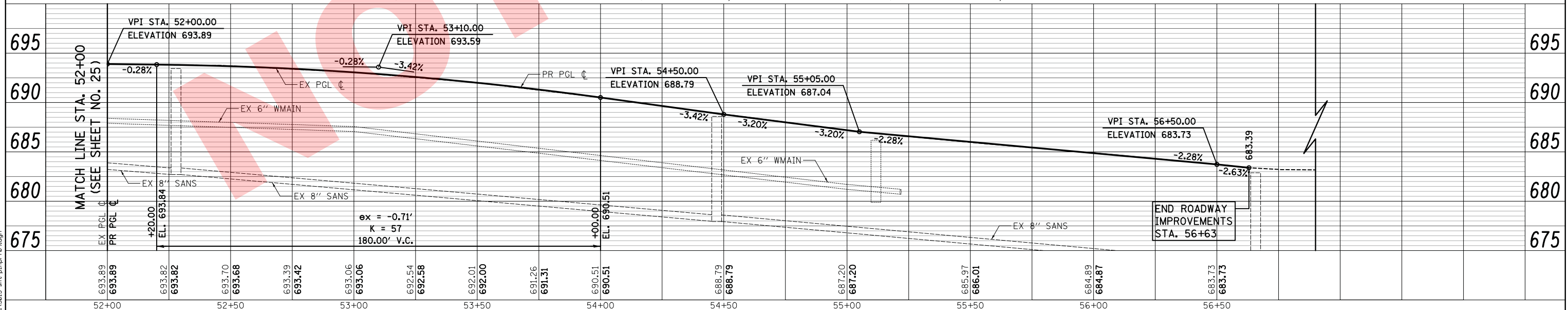

USER NAME = mjp	DESIGNED - MJP	REVISED -
	DRAWN - NEM	REVISED -
	CHECKED - DNM	REVISED -
	DATE - 04/15/16	REVISED -

VILLAGE OF VILLA PARK

**MONROE STREET
ROADWAY REMOVAL, PROPOSED PLAN AND PROFILE**

SCALE: 1" = 20' SHEET OF SHEETS STA. 52+00 TO STA. 56+62.7

F.A. RTE.	SECTION	COUNTY	TOTAL SHEETS	SHEET NO.
		DUPAGE	62	26
CONTRACT NO.				
ILLINOIS FED. AID PROJECT				

DATE	
BY	
PLAN	
NO.	
NO.	
NO.	
NO.	
NO.	
NO.	
NO.	

DATE	
BY	
PROFILE	
NO.	
NO.	
NO.	
NO.	
NO.	
NO.	
NO.	

PLOT DRIVER = ...
 PLOT NAME = ...
 FILE NAME = ...

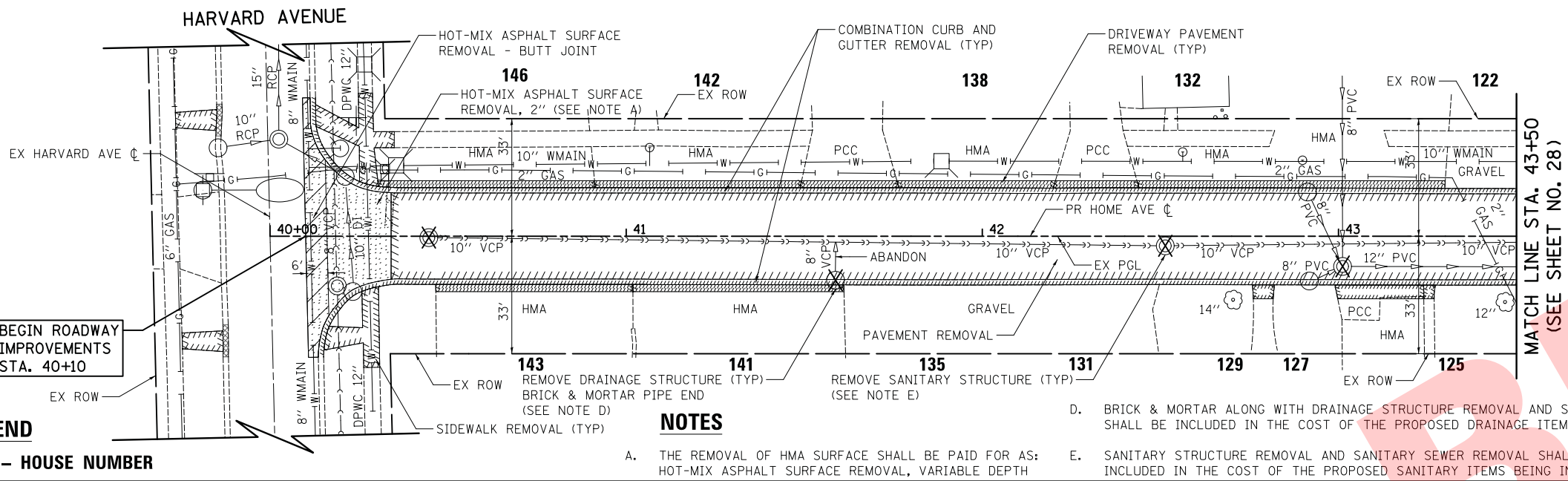

HOME AVENUE CROSS-SLOPE TRANSITION TABLE				
EASTBOUND MOVEMENT				
STATION	PGL ELEVATION	CROSS SLOPE	WIDTH FROM PGL TO EOP (RT)	EOP ELEVATION (RT OF PGL)
40+10.0	700.12		MATCH EXISTING	
40+34.0	699.74	-2.50%	12.0	699.44
41+10.0	699.32	-2.50%	12.0	699.02
41+60.0	699.05	-3.50%	12.0	698.63
42+60.0	698.51	-2.50%	12.0	698.21
43+50.0	698.02	-2.50%	12.0	697.72
44+00.0	697.74	-2.00%	12.0	697.50
46+60.0	696.33	-2.00%	12.0	696.09
47+00.0	696.11	-2.80%	12.0	695.77
47+01.0	696.10		MATCH EXISTING	
52+65.0	693.52		MATCH EXISTING	

LEGEND

- HOUSE NUMBER

NOTES

- A. THE REMOVAL OF HMA SURFACE SHALL BE PAID FOR AS: HOT-MIX ASPHALT SURFACE REMOVAL, VARIABLE DEPTH
- B. BRICK & MORTAR ALONG WITH DRAINAGE STRUCTURE REMOVAL AND STORM SEWER REMOVAL SHALL BE INCLUDED IN THE COST OF THE PROPOSED DRAINAGE ITEMS BEING INSTALLED.
- C. SANITARY STRUCTURE REMOVAL AND SANITARY SEWER REMOVAL SHALL BE INCLUDED IN THE COST OF THE PROPOSED SANITARY ITEMS BEING INSTALLED.

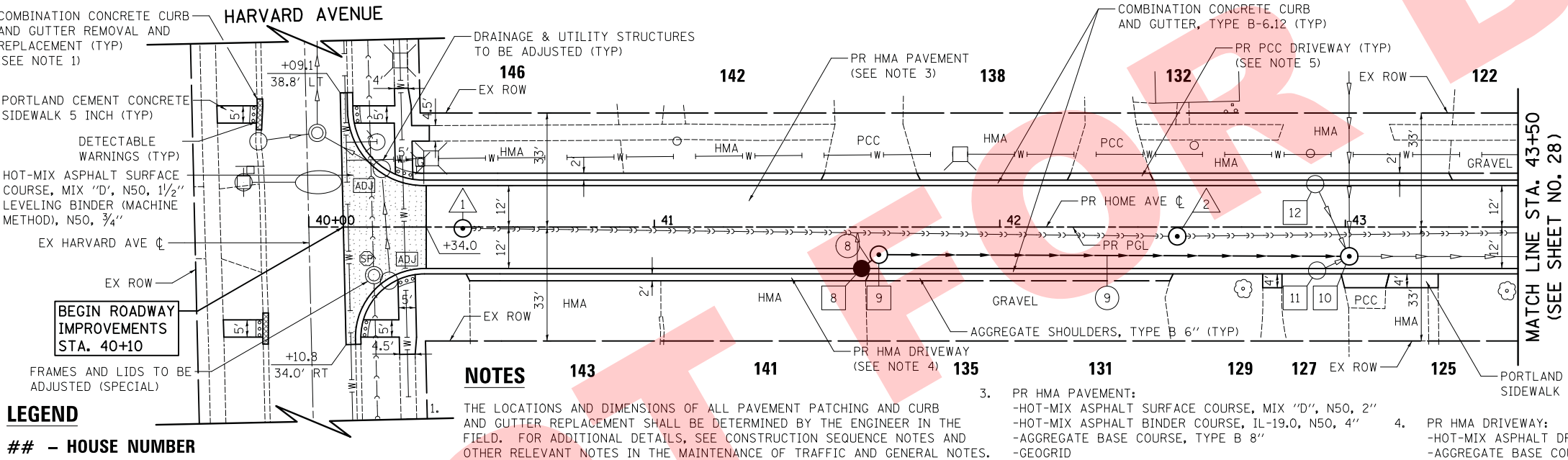

HOME AVENUE CROSS-SLOPE TRANSITION TABLE				
WESTBOUND MOVEMENT				
STATION	PGL ELEVATION	CROSS SLOPE	WIDTH FROM PGL TO EOP (LT)	EOP ELEVATION (LT OF PGL)
40+10.0	700.12		MATCH EXISTING	
40+34.0	699.74	-3.00%	12.0	699.38
42+65.0	698.48	-3.00%	12.0	698.12
42+90.0	698.34	-3.50%	12.0	697.92
43+00.0	698.29	-3.50%	12.0	697.87
44+50.0	697.47	-2.00%	12.0	697.23
45+50.0	696.93	-2.00%	12.0	696.69
46+25.0	696.52	-1.25%	12.0	696.37
46+45.0	696.41	-2.00%	12.0	696.17
46+85.0	696.19	-4.00%	12.0	695.71
47+00.0	696.11	-4.00%	12.0	695.63
47+01.0	696.10		MATCH EXISTING	
52+65.0	693.52		MATCH EXISTING	

LEGEND

- HOUSE NUMBER

NOTES

- 1. THE LOCATIONS AND DIMENSIONS OF ALL PAVEMENT PATCHING AND CURB AND GUTTER REPLACEMENT SHALL BE DETERMINED BY THE ENGINEER IN THE FIELD. FOR ADDITIONAL DETAILS, SEE CONSTRUCTION SEQUENCE NOTES AND OTHER RELEVANT NOTES IN THE MAINTENANCE OF TRAFFIC AND GENERAL NOTES.
- 2. PR HMA DRIVEWAY: -HOT-MIX ASPHALT DRIVEWAY PAVEMENT, 6" -AGGREGATE BASE COURSE, TYPE B 8"
- 3. PR HMA PAVEMENT: -HOT-MIX ASPHALT SURFACE COURSE, MIX "D", N50, 2" -HOT-MIX ASPHALT BINDER COURSE, IL-19.0, N50, 4" -AGGREGATE BASE COURSE, TYPE B 8" -GEOGRID
- 4. PR PCC DRIVEWAY: -PORTLAND CEMENT CONCRETE DRIVEWAY PAVEMENT, 8 INCH -AGGREGATE BASE COURSE, TYPE B 6"
- 5. PR DRIVEWAY: -HOT-MIX ASPHALT DRIVEWAY PAVEMENT, 6" -AGGREGATE BASE COURSE, TYPE B 8"

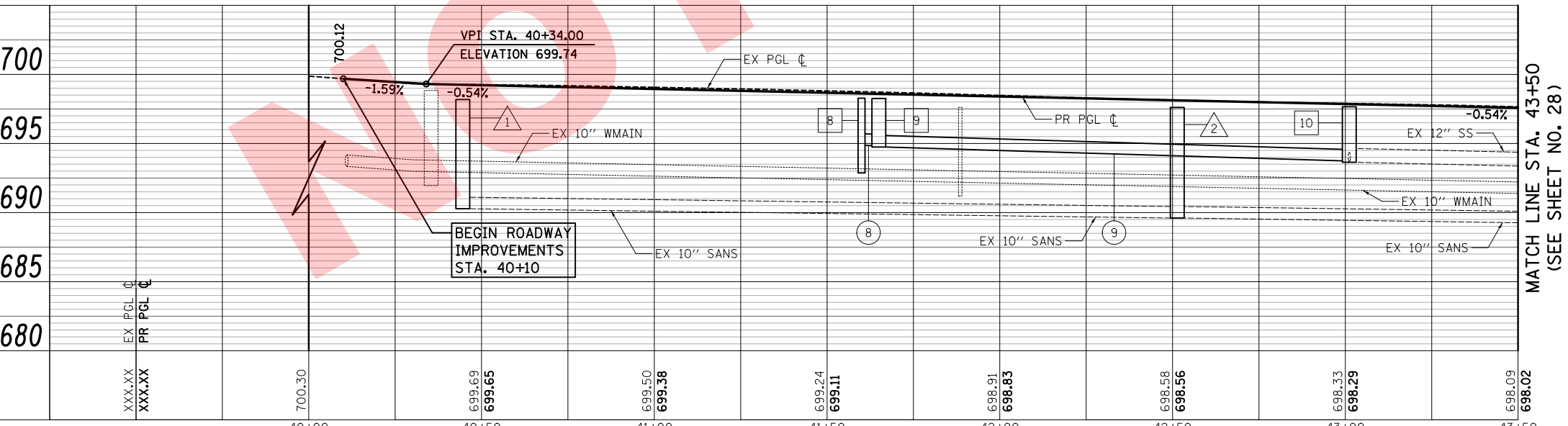

- 1. STA 40+44.6, 0.4' RT SAN MAN 4 DIA TIF CL RIM = 699.67 INV = 690.71 (EX 10" E)
- 2. STA 42+51.4, 2.7' RT SAN MAN 4 DIA TIF CL RIM = 698.48 INV = 690.03 (EX 10" W) INV = 690.03 (EX 10" E)
- 8. STA 41+60.0, 12.0' RT CB TC T11F&G (CURB PLATE) RIM = 698.63 INV = 695.30 (10" NE)
- 9. STA 41+65.0, 8.0' RT MAN TA 4 DIA TIF CL RIM = 698.75 INV = 695.27 (10" SW) INV = 695.17 (10" E)
- 10. STA 43+01.2, 8.5' RT MAN TA 4 DIA TIF CL RIM = 698.07 INV = 694.17 (10" W) INV = 694.12 (EX 8" SW) INV = 694.12 (EX 8" N) INV = 694.09 (EX 8" NW) INV = 694.07 (EX 12" E)
- 11. STA 42+91.8, 12.0' RT DRAIN UTIL STR RECON FR & GRATES T11 EX RIM = 698.08 PR RIM = 698.03
- 12. STA 42+91.3, 12.0' LT DRAIN UTIL STR ADJ FR & GRATES T11 (CURB PLATE) EX RIM = 697.89 PR RIM = 697.91
- 8. 4' - STORM SEW CL B 1, 10" PVC @ 0.75% T.B.F. = 0.7 CU YD
- 9. 133' - STORM SEW CL B 2, 10" PVC @ 0.75% T.B.F. = 25.9 CU YD

HOME AVENUE - PROPOSED PLAN



USER NAME = mjp	DESIGNED - MJP	REVISED -
	DRAWN - NEM	REVISED -
PLOT SCALE = 20.0000' / in.	CHECKED - DNM	REVISED -
PLOT DATE = 4/14/2016	DATE - 04/15/16	REVISED -

VILLAGE OF VILLA PARK

HOME AVENUE ROADWAY REMOVAL, PROPOSED PLAN AND PROFILE

SCALE: 1" = 20' SHEET OF SHEETS STA. 40+10 TO STA. 43+50

F.A. RTE.	SECTION	COUNTY	TOTAL SHEETS	SHEET NO.
		DUPAGE	62	27
CONTRACT NO.				
ILLINOIS FED. AID PROJECT				

PLAN	SURVEYED	DATE
	PLOTTED	
	CHECKED	
	BY	
	NO.	

PROFILE	SURVEYED	DATE
	PLOTTED	
	CHECKED	
	BY	
	NO.	

PLOT DRIVER = ...
 PLOT FILE = ...
 FILE NAME = ...

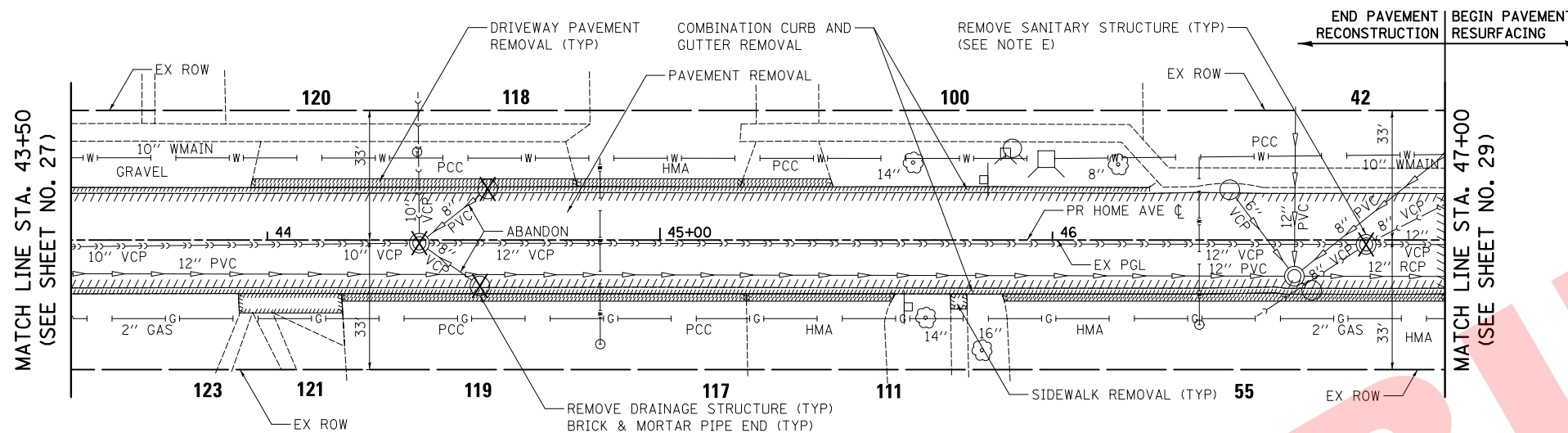

LEGEND

- HOUSE NUMBER

NOTES

- D. BRICK & MORTAR ALONG WITH DRAINAGE STRUCTURE REMOVAL AND STORM SEWER REMOVAL SHALL BE INCLUDED IN THE COST OF THE PROPOSED DRAINAGE ITEMS BEING INSTALLED.
- E. SANITARY STRUCTURE REMOVAL AND SANITARY SEWER REMOVAL SHALL BE INCLUDED IN THE COST OF THE PROPOSED SANITARY ITEMS BEING INSTALLED.

HOME AVENUE - REMOVAL PLAN

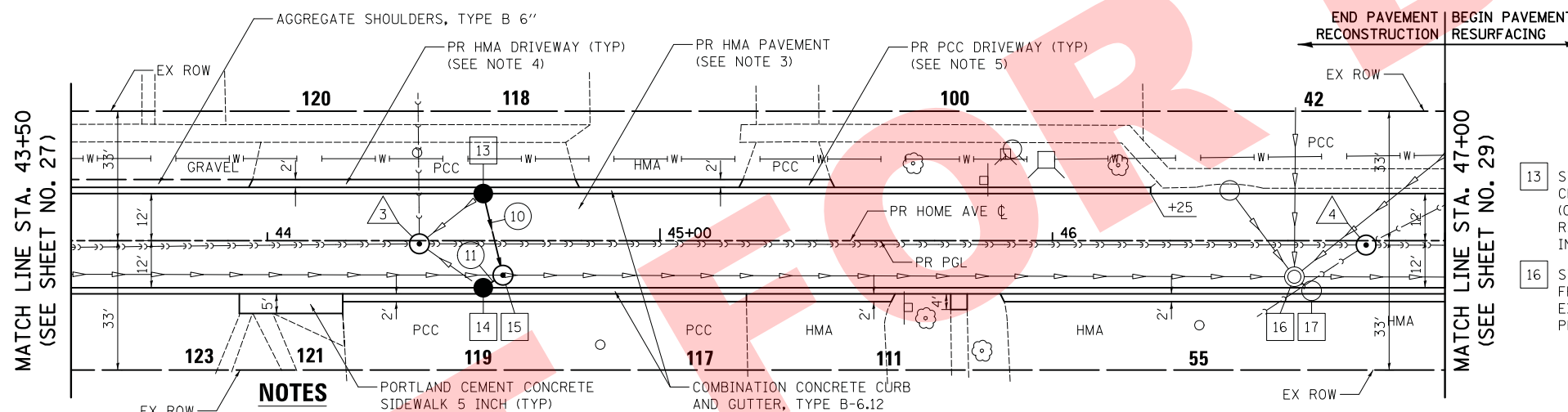

LEGEND

- HOUSE NUMBER

- 3. PR HMA PAVEMENT:
 -HOT-MIX ASPHALT SURFACE COURSE, MIX "D", N50, 2"
 -HOT-MIX ASPHALT BINDER COURSE, 1L-19.0, N50, 4"
 -AGGREGATE BASE COURSE, TYPE B 8"
 -GEOGRID
- 4. PR HMA DRIVEWAY:
 -HOT-MIX ASPHALT DRIVEWAY PAVEMENT, 6"
 -AGGREGATE BASE COURSE, TYPE B 8"
- 5. PR PCC DRIVEWAY:
 -PORTLAND CEMENT CONCRETE DRIVEWAY PAVEMENT, 8 INCH
 -AGGREGATE BASE COURSE, TYPE B 6"

- 3. STA 44+38.7, 0.8' RT SAN MAN 4 DIA TIF CL
 RIM = 697.52
 INV = 690.31 (EX 8" N)
 INV = 689.39 (EX 10" W)
 INV = 689.39 (EX 12" E)
- 4. STA 46+79.9, 1.1' RT SAN MAN 4 DIA TIF CL
 RIM = 696.19
 INV = 692.78 (EX 8" NE)
 INV = 692.67 (EX 8" SW)
 INV = 688.92 (EX 12" W)
 INV = 688.92 (EX 12" E)
- 10. 20' - STORM SEW CL B 1, 10" PVC @ 1.00%
 T.B.F. = 2.8 CU YD
- 11. 4' - STORM SEW CL B 1, 10" PVC @ 1.00%
 T.B.F. = 0.6 CU YD
- 13. STA 44+55.0, 12.0' LT CB TC T11F&G (CURB PLATE)
 RIM = 697.21
 INV = 694.21 (10" SE)
- 14. STA 44+55.0, 12.0' RT CB TC T11F&G (CURB PLATE)
 RIM = 697.21
 INV = 694.21 (10" NE)
- 15. STA 44+60.0, 8.8' RT MAN TA 4 DIA TIF CL
 RIM = 697.24
 INV = 694.17 (10" SW)
 INV = 694.01 (10" NW)
 INV = 693.17 (EX 12" W)
 INV = 693.15 (EX 12" E)
- 16. STA 46+61.6, 9.2' RT FR & LIDS ADJUST SPL
 EX RIM = 696.05
 PR RIM = 696.13
- 17. STA 46+66.0, 12.0' RT DRAIN UTIL STR ADJ FR & GRATES T11 (CURB PLATE)
 EX RIM = 696.05
 PR RIM = 696.04

HOME AVENUE - PROPOSED PLAN

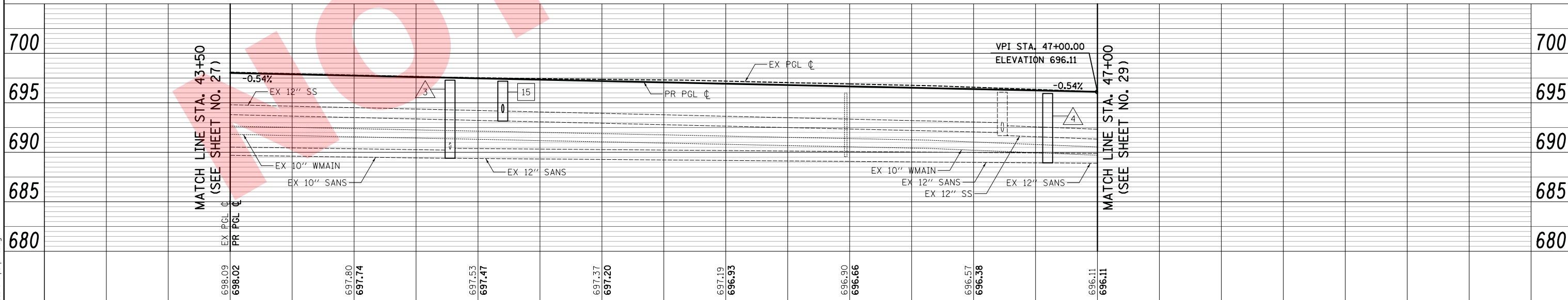

	USER NAME = mjp	DESIGNED - MJP	REVISED -	VILLAGE OF VILLA PARK HOME AVENUE ROADWAY REMOVAL, PROPOSED PLAN AND PROFILE	F.A. RTE.	SECTION	COUNTY	TOTAL SHEETS	SHEET NO.	
	PLOT SCALE = 20.0000' / in.	DRAWN - NEM	REVISED -		DUPAGE	62	28	CONTRACT NO.		
	PLOT DATE = 4/14/2016	CHECKED - DNM	REVISED -		SCALE: 1" = 20'	SHEET OF SHEETS	STA. 43+50 TO STA. 47+00	ILLINOIS FED. AID PROJECT		
		DATE - 04/15/16	REVISED -							

PLAN	SURVEYED	DATE
	PLOTTED	
	CHECKED	
	BY	
	NO.	

PROFILE	SURVEYED	DATE
	GRADES CHECKED	
	STRUCTURE NOTATIONS OK'D	
	NO.	

PLOT DRIVER = ...mjp\...0314\...pdf.plt
 PLOT NAME = ...9161\...tbl\...tbl.dwg
 FILE NAME = ...385\...tbl\...tbl.dwg

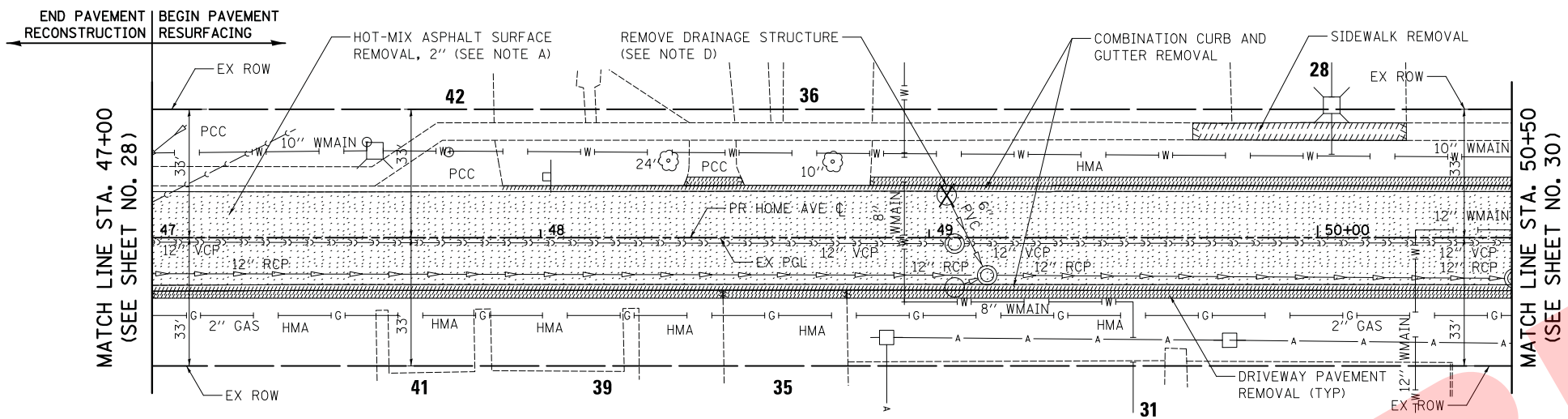

LEGEND

- HOUSE NUMBER

NOTES

- A. THE REMOVAL OF HMA SURFACE SHALL BE PAID FOR AS: HOT-MIX ASPHALT SURFACE REMOVAL, VARIABLE DEPTH
- D. DRAINAGE STRUCTURE REMOVAL AND STORM SEWER REMOVAL SHALL BE INCLUDED IN THE COST OF THE PROPOSED DRAINAGE ITEMS BEING INSTALLED.

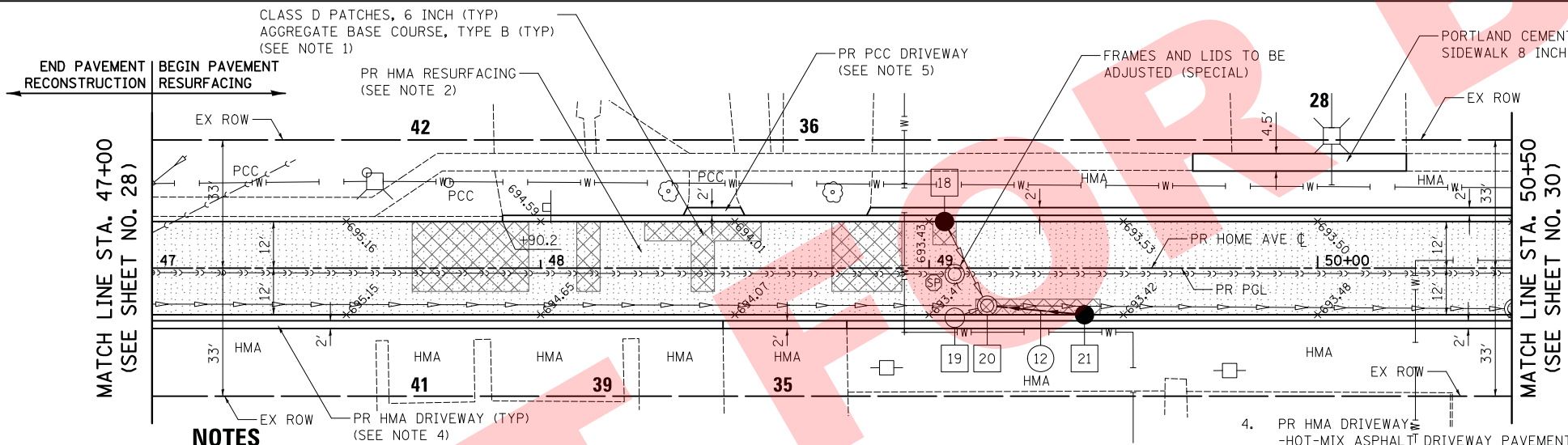

LEGEND

- HOUSE NUMBER

- 1. THE LOCATIONS AND DIMENSIONS OF ALL PAVEMENT PATCHING SHALL BE DETERMINED BY THE ENGINEER IN THE FIELD. FOR ADDITIONAL DETAILS, SEE CONSTRUCTION SEQUENCE NOTES AND OTHER RELEVANT NOTES IN THE MAINTENANCE OF TRAFFIC AND GENERAL NOTES.
- 2. PR HMA RESURFACING:
 -HOT-MIX ASPHALT SURFACE COURSE, MIX 'D', N50, 1/2"
 -LEVELING BINDER (MACHINE METHOD), N50, 3/4"
- 3. PR HMA DRIVEWAY (SEE NOTE 4)
 -HOT-MIX ASPHALT DRIVEWAY PAVEMENT, 6"
 -AGGREGATE BASE COURSE, TYPE B 8"
- 4. PR PCC DRIVEWAY (SEE NOTE 5)
 -PORTLAND CEMENT CONCRETE DRIVEWAY PAVEMENT, 8 INCH
 -AGGREGATE BASE COURSE, TYPE B 6"

- 18 STA 49+04.0, 12.0' LT CB TC T11F&G (CURB PLATE) RIM = 693.49 INV = 691.14 (EX 6" SE)
- 19 STA 49+06.6, 12.0' RT DRAIN UTIL STR ADJ FR & GRATES T11 (CURB PLATE)
- 20 STA 49+15.0, 9.7' RT FR & LIDS ADJUST SPL RIM = 693.50 INV = 690.98 (8" SE) INV = 689.93 (EX 6" NW) INV = 689.63 (EX 6" SW) INV = 689.25 (EX 12" W) INV = 689.25 (EX 12" E)
- 21 STA 49+40.0, 12.0' RT CB TC T11F&G (CURB PLATE) RIM = 693.40 INV = 691.21 (8" NW)
- 12 23' - STORM SEW WM REQ, 8" @ 1.00% T.B.F. = 3.2 CU YD

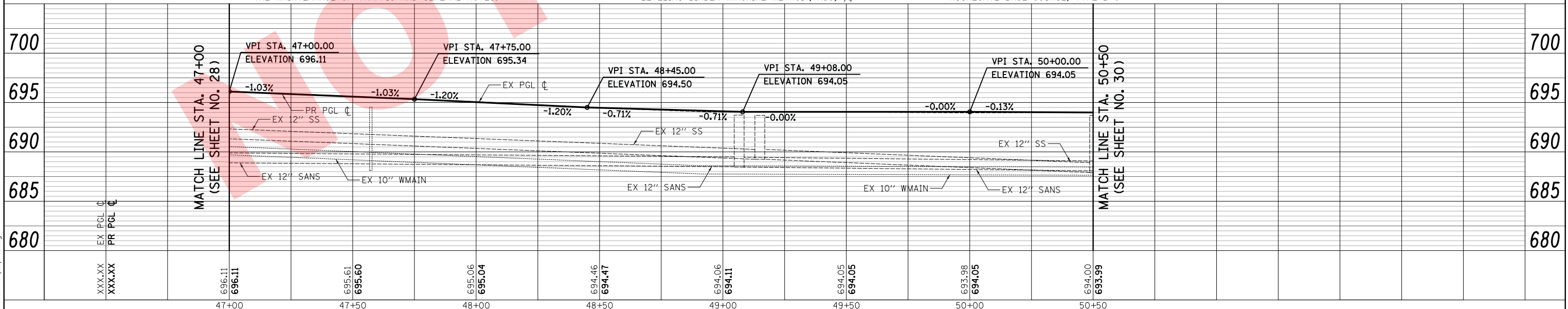

USER NAME = mjp	DESIGNED - MJP	REVISED -
	DRAWN - NEM	REVISED -
PLOT SCALE = 20.0000' / in.	CHECKED - DNM	REVISED -
PLOT DATE = 4/14/2016	DATE - 04/15/16	REVISED -

VILLAGE OF VILLA PARK

**HOME AVENUE
ROADWAY REMOVAL, PROPOSED PLAN AND PROFILE**

SCALE: 1" = 20' SHEET OF SHEETS STA. 47+00 TO STA. 50+50

F.A. RTE.	SECTION	COUNTY	TOTAL SHEETS	SHEET NO.
		DUPAGE	62	29
CONTRACT NO.				
ILLINOIS FED. AID PROJECT				

PLAN	SURVEYED	DATE
	PLOTTED	
	CHECKED	
	BY	
	NO. 1	
	NO. 2	
	NO. 3	
	NO. 4	
	NO. 5	
	NO. 6	
	NO. 7	
	NO. 8	
	NO. 9	
	NO. 10	

PROFILE	SURVEYED	DATE
	PLOTTED	
	CHECKED	
	BY	
	NO. 1	
	NO. 2	
	NO. 3	
	NO. 4	
	NO. 5	
	NO. 6	
	NO. 7	
	NO. 8	
	NO. 9	
	NO. 10	

PLOT DRIVER = ...mjp\vdms09314\...
 PLOT NAME = ...9314\...
 FILE NAME = ...9314\...
 FILE NAME = ...9314\...

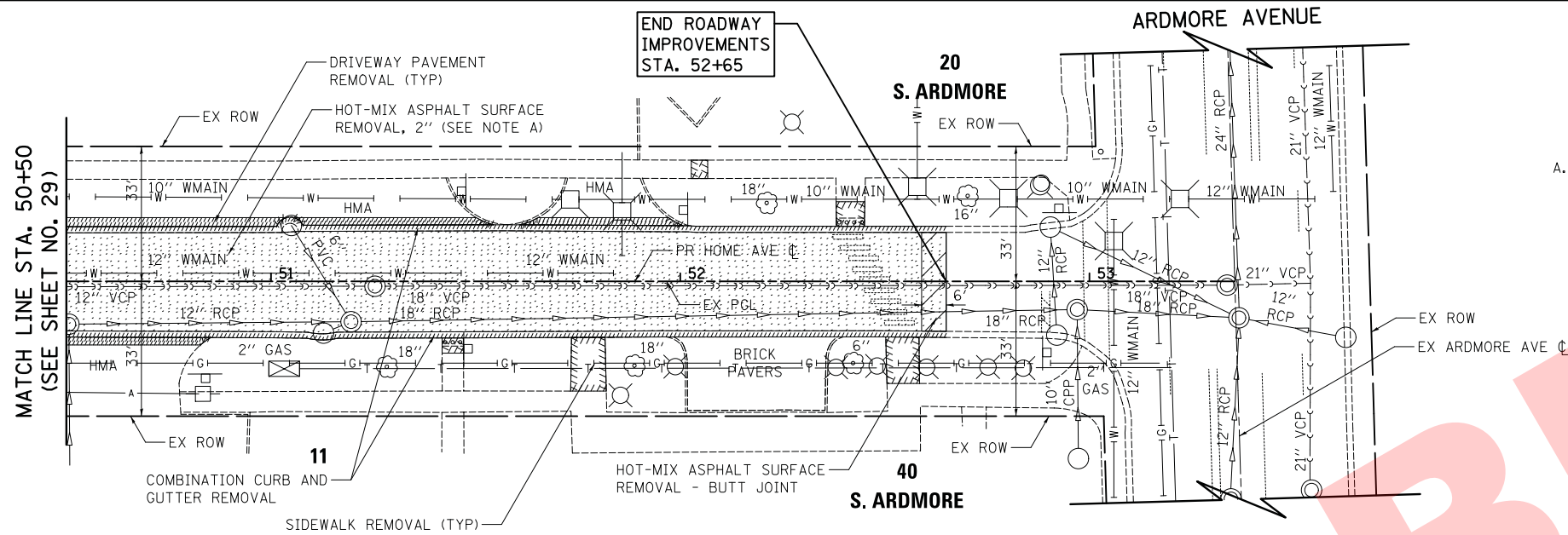

NOTES

- A. THE REMOVAL OF HMA SURFACE SHALL BE PAID FOR AS: HOT-MIX ASPHALT SURFACE REMOVAL, VARIABLE DEPTH



LEGEND

- HOUSE NUMBER

HOME AVENUE - REMOVAL PLAN

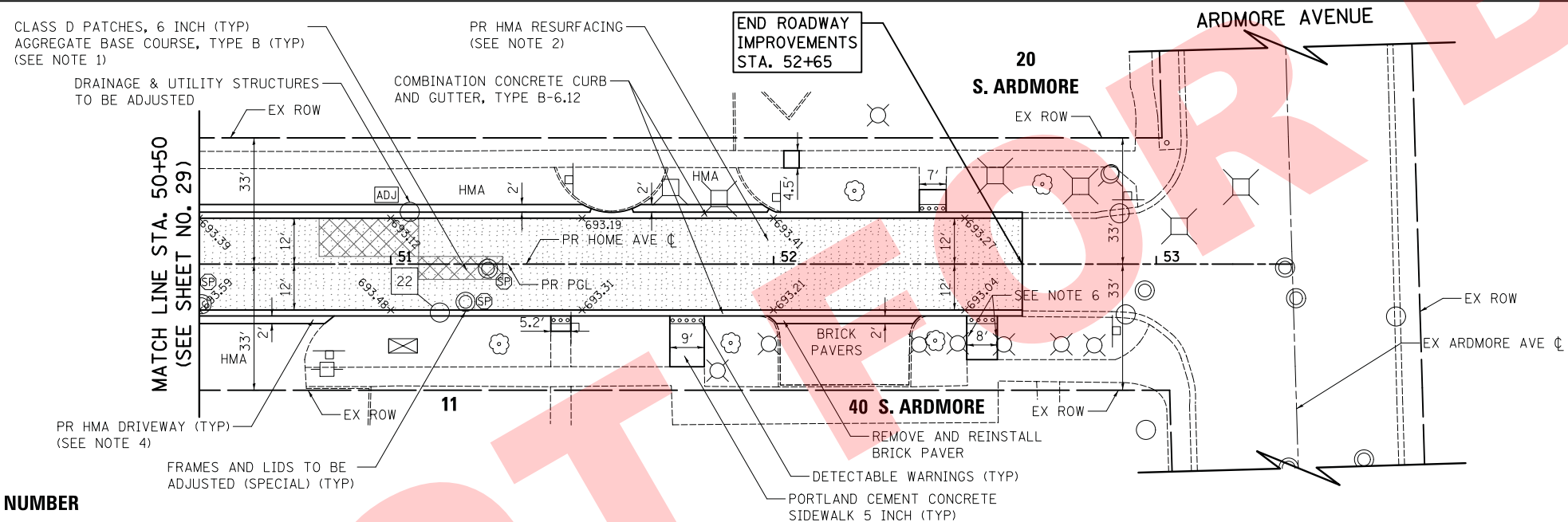

NOTES

- 1. THE LOCATIONS AND DIMENSIONS OF ALL PAVEMENT PATCHING SHALL BE DETERMINED BY THE ENGINEER IN THE FIELD. FOR ADDITIONAL DETAILS, SEE CONSTRUCTION SEQUENCE NOTES AND OTHER RELEVANT NOTES IN THE MAINTENANCE OF TRAFFIC AND GENERAL NOTES.
 - 2. PR HMA RESURFACING:
 -HOT-MIX ASPHALT SURFACE COURSE, MIX "D", N50, 1 1/2"
 -LEVELING BINDER (MACHINE METHOD), N50, 3/4"
 - 4. PR HMA DRIVEWAY:
 -HOT-MIX ASPHALT DRIVEWAY PAVEMENT, 6"
 -AGGREGATE BASE COURSE, TYPE B 8"
 - 6. THE REMOVAL AND REINSTALLATION OF BRICK PAVERS (INCLUDING PERMEABLE PAVERS) ALONG THE SIDE OF THE SIDEWALK SHALL BE INCLUDED IN THE AREA AND COST OF: PORTLAND CEMENT CONCRETE SIDEWALK 5 INCH
- 22 STA 51+12.8, 12.0' RT DRAIN UTIL STR ADJ FR & GRATES T11



LEGEND

- HOUSE NUMBER

HOME AVENUE - PROPOSED PLAN

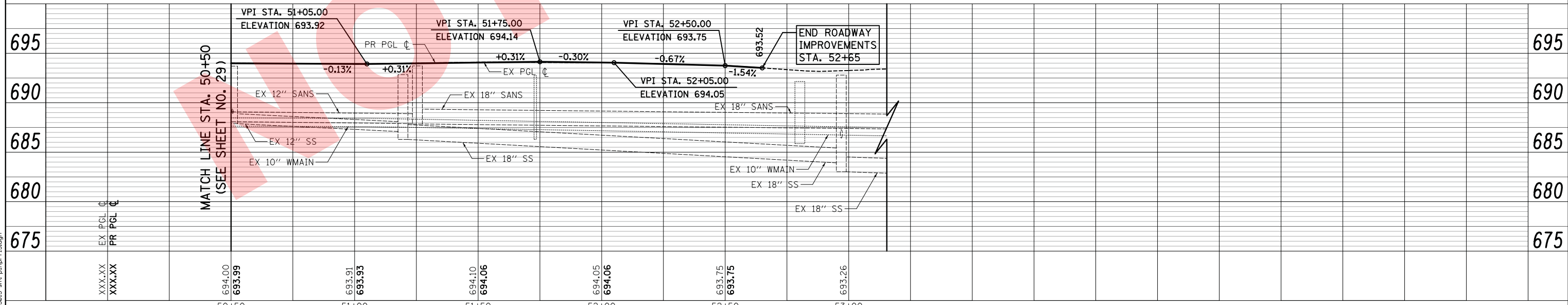

	USER NAME = mjp	DESIGNED - MJP	REVISED -	VILLAGE OF VILLA PARK HOME AVENUE ROADWAY REMOVAL, PROPOSED PLAN AND PROFILE	F.A. RTE.	SECTION	COUNTY	TOTAL SHEETS	SHEET NO.
	PLOT SCALE = 20.0000' / in.	CHECKED - DNM	REVISED -		SCALE: 1" = 20'	SHEET	OF	SHEETS	STA. 50+50
	PLOT DATE = 4/14/2016	DATE - 04/15/16	REVISED -		CONTRACT NO.				ILLINOIS FED. AID PROJECT

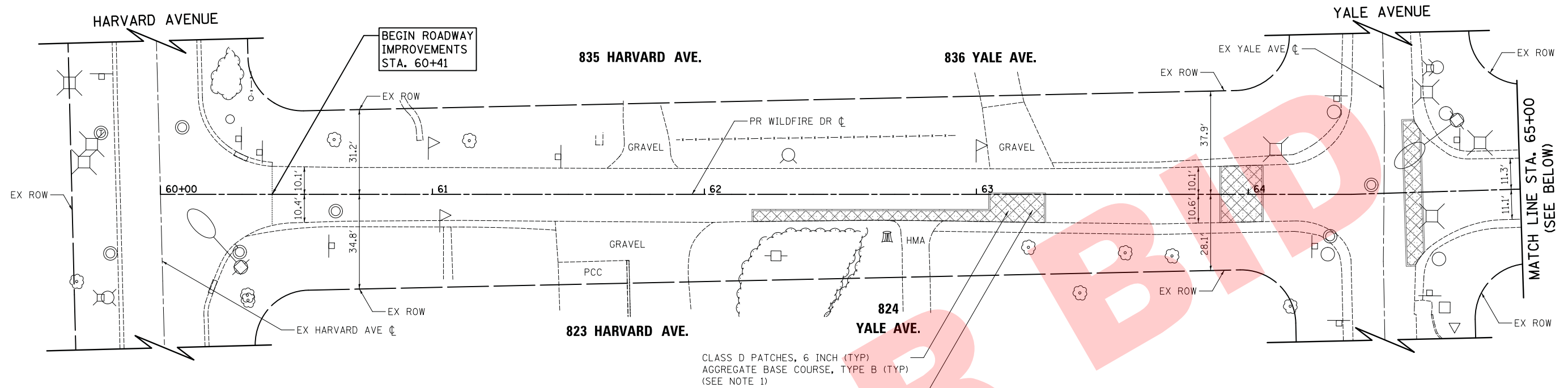

LEGEND

- HOUSE NUMBER

WILDFIRE DRIVE - PROPOSED PLAN

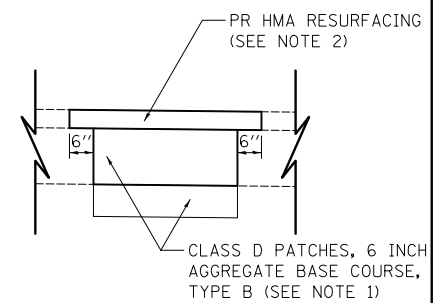
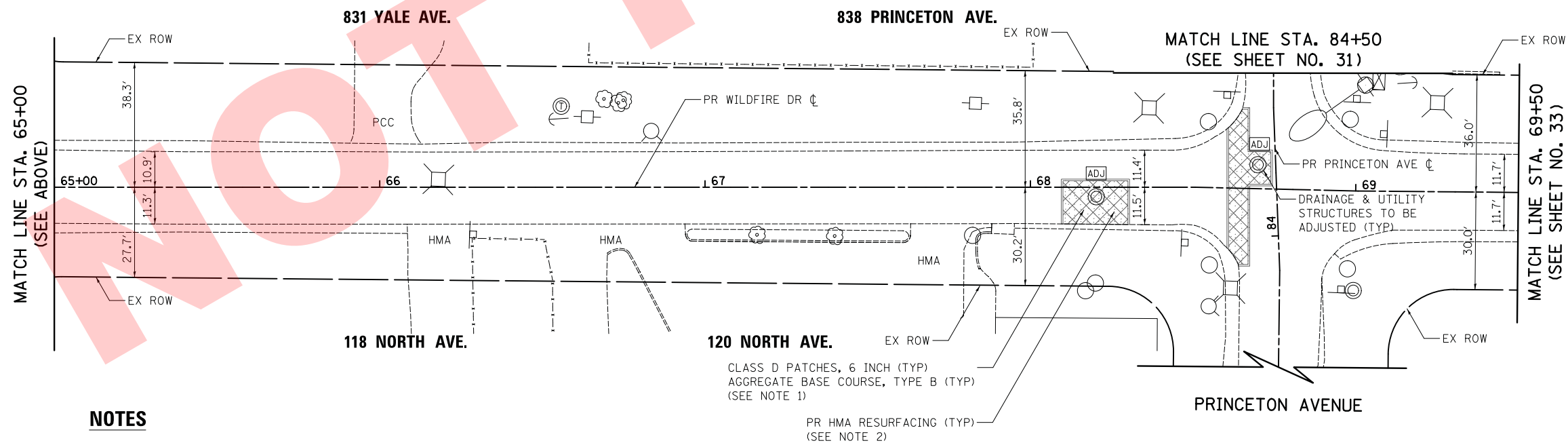

WILDFIRE PATCHING DETAIL

NOTES

1. THE LOCATIONS AND DIMENSIONS OF ALL PAVEMENT PATCHING SHALL BE DETERMINED BY THE ENGINEER IN THE FIELD. FOR ADDITIONAL DETAILS, SEE CONSTRUCTION SEQUENCE NOTES AND OTHER RELEVANT NOTES IN THE MAINTENANCE OF TRAFFIC AND GENERAL NOTES.
2. PR HMA RESURFACING:
 -HOT-MIX ASPHALT SURFACE REMOVAL, 2" (PAID FOR AS "HOT-MIX ASPHALT SURFACE REMOVAL, VARIABLE DEPTH")
 -HOT-MIX ASPHALT SURFACE COURSE, MIX "D", N50, 2"

LEGEND

- HOUSE NUMBER

WILDFIRE DRIVE - PROPOSED PLAN

PLOT DRIVER = ...\\n:\p\dms\0314\ven\pdf\p1.t
 PEN TABLE = ...\\pemb\cui\dat_ppd\tbl1
 FILE NAME = ...\\3015-shr-pla\p1.dgn



USER NAME = mjp	DESIGNED - MJP	REVISED -
	DRAWN - NEM	REVISED -
PLOT SCALE = 20.0000' / in.	CHECKED - DNM	REVISED -
PLOT DATE = 4/14/2016	DATE - 04/15/16	REVISED -

VILLAGE OF VILLA PARK

WILDFIRE DRIVE
 PROPOSED ROADWAY PLAN

SCALE: 1" = 20' SHEET OF SHEETS STA. 60+41 TO STA. 69+50

F.A. RTE.	SECTION	COUNTY	TOTAL SHEETS	SHEET NO.
		DUPAGE	62	32
CONTRACT NO.				
ILLINOIS FED. AID PROJECT				

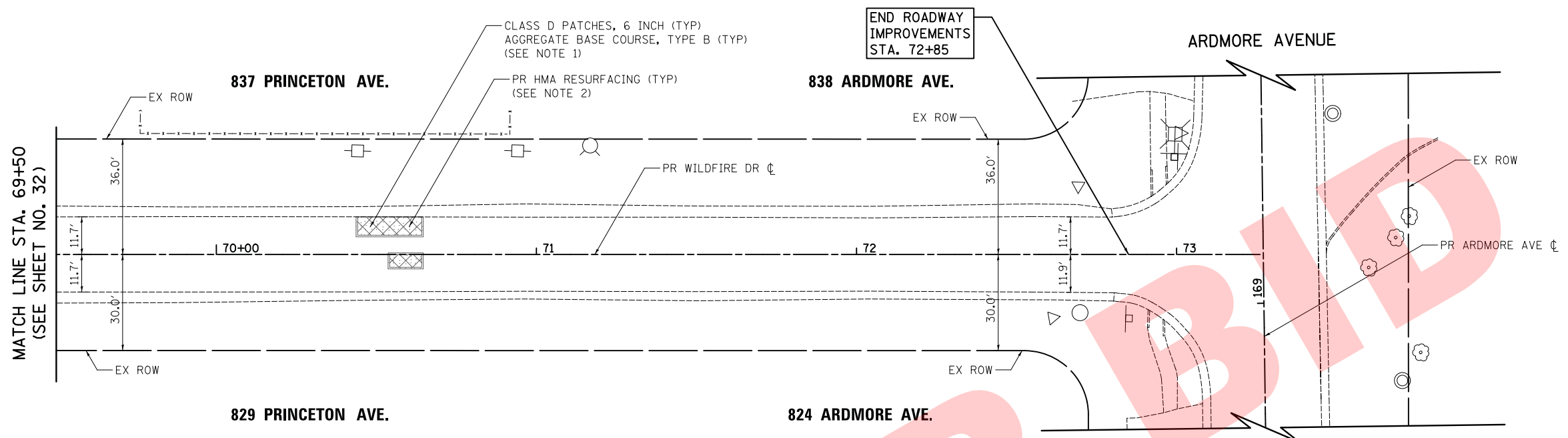

LEGEND

- HOUSE NUMBER

NOTES

1. THE LOCATIONS AND DIMENSIONS OF ALL PAVEMENT PATCHING SHALL BE DETERMINED BY THE ENGINEER IN THE FIELD. FOR ADDITIONAL DETAILS, SEE CONSTRUCTION SEQUENCE NOTES AND OTHER RELEVANT NOTES IN THE MAINTENANCE OF TRAFFIC AND GENERAL NOTES.
2. PR HMA RESURFACING:
 - HOT-MIX ASPHALT SURFACE REMOVAL, 2" (PAID FOR AS "HOT-MIX ASPHALT SURFACE REMOVAL, VARIABLE DEPTH")
 - HOT-MIX ASPHALT SURFACE COURSE, MIX "D", N50, 2"

WILDFIRE DRIVE - PROPOSED PLAN

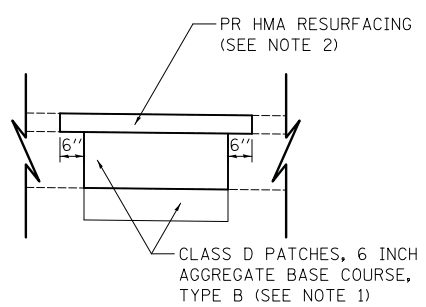

WILDFIRE PATCHING DETAIL

PLOT DRIVER = ...\\mjb\cma\0314\cma_plt.pnt
 PEN TABLE = ...\\mjb\cma\cma_plt.pnt
 FILE NAME = ...\\3015-shr-pla-02.dgn



USER NAME = mjp	DESIGNED - MJP	REVISED -
	DRAWN - NEM	REVISED -
PLOT SCALE = 20.0000' / in.	CHECKED - DNM	REVISED -
PLOT DATE = 4/14/2016	DATE - 04/15/16	REVISED -

VILLAGE OF VILLA PARK

**WILDFIRE DRIVE
 PROPOSED ROADWAY PLAN**

SCALE: 1" = 20' SHEET OF SHEETS STA. 69+50 TO STA. 72+85

F.A. RTE.	SECTION	COUNTY	TOTAL SHEETS	SHEET NO.
		DUPAGE	62	33
CONTRACT NO.				
ILLINOIS FED. AID PROJECT				

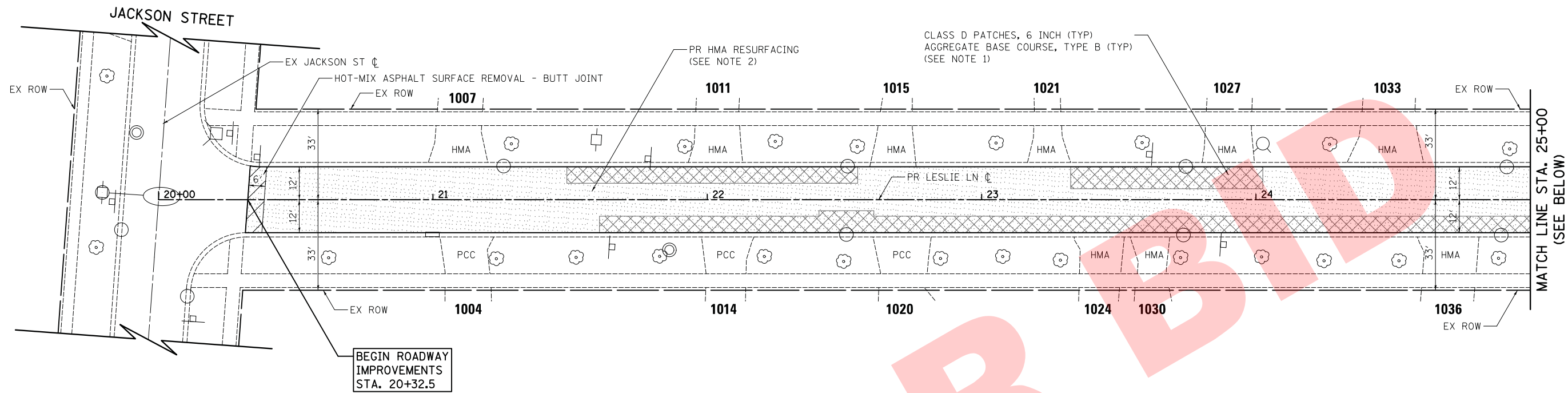
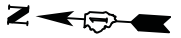

LEGEND

- HOUSE NUMBER

LESLIE LANE - PROPOSED PLAN

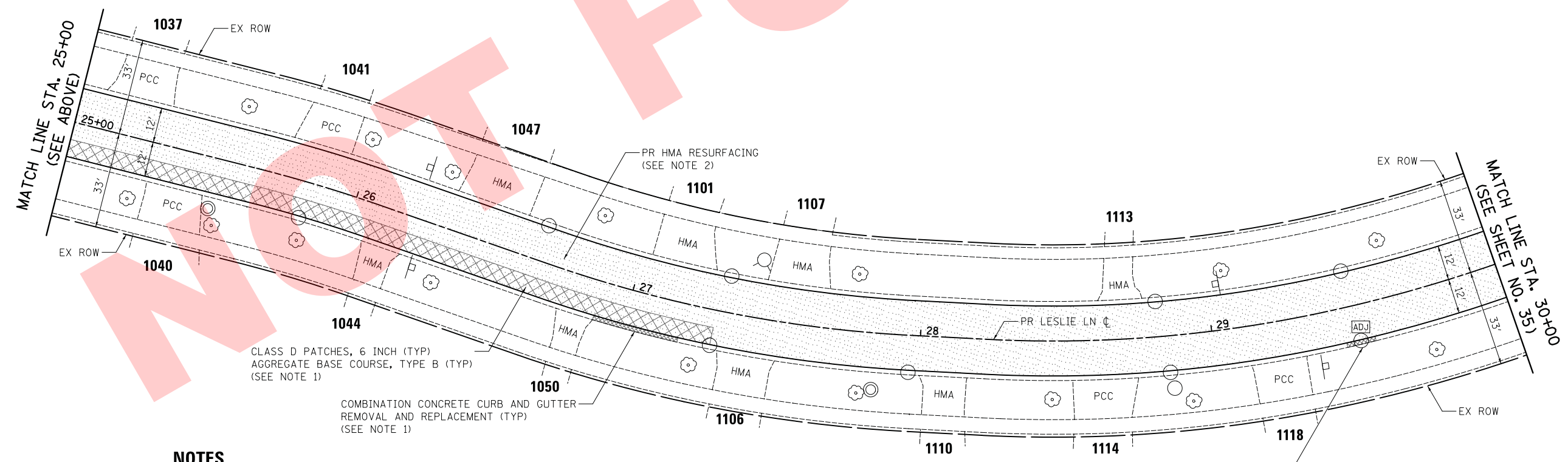

NOTES

1. THE LOCATIONS AND DIMENSIONS OF ALL PAVEMENT PATCHING AND CURB AND GUTTER REPLACEMENT SHALL BE DETERMINED BY THE ENGINEER IN THE FIELD. FOR ADDITIONAL DETAILS, SEE CONSTRUCTION SEQUENCE NOTES AND OTHER RELEVANT NOTES IN THE MAINTENANCE OF TRAFFIC AND GENERAL NOTES.
2. PR HMA RESURFACING:
 -HOT-MIX ASPHALT SURFACE REMOVAL, 2" (PAID FOR AS "HOT-MIX ASPHALT SURFACE REMOVAL, VARIABLE DEPTH")
 -HOT-MIX ASPHALT SURFACE COURSE, MIX "D", N50, 1 1/2"
 -LEVELING BINDER (MACHINE METHOD), N50, 3/4"

LEGEND

- HOUSE NUMBER

LESLIE LANE - PROPOSED PLAN

PLOT DRIVER = ...\\n:\p\dms\0314\...
 PEN TABLE = ...\\p\tbl\...
 FILE NAME = ...3815-shr-pla-03.dgn



USER NAME = mjp	DESIGNED - MJP	REVISED -
PLOT SCALE = 20.0000' / in.	DRAWN - NEM	REVISED -
PLOT DATE = 4/14/2016	CHECKED - DNM	REVISED -
	DATE - 04/15/16	REVISED -

VILLAGE OF VILLA PARK

LESLIE LANE
PROPOSED ROADWAY PLAN

SCALE: 1" = 20' SHEET OF SHEETS STA. 20+32.5 TO STA. 30+00

F.A. RTE.	SECTION	COUNTY	TOTAL SHEETS	SHEET NO.
		DUPAGE	62	34
CONTRACT NO.				
ILLINOIS FED. AID PROJECT				

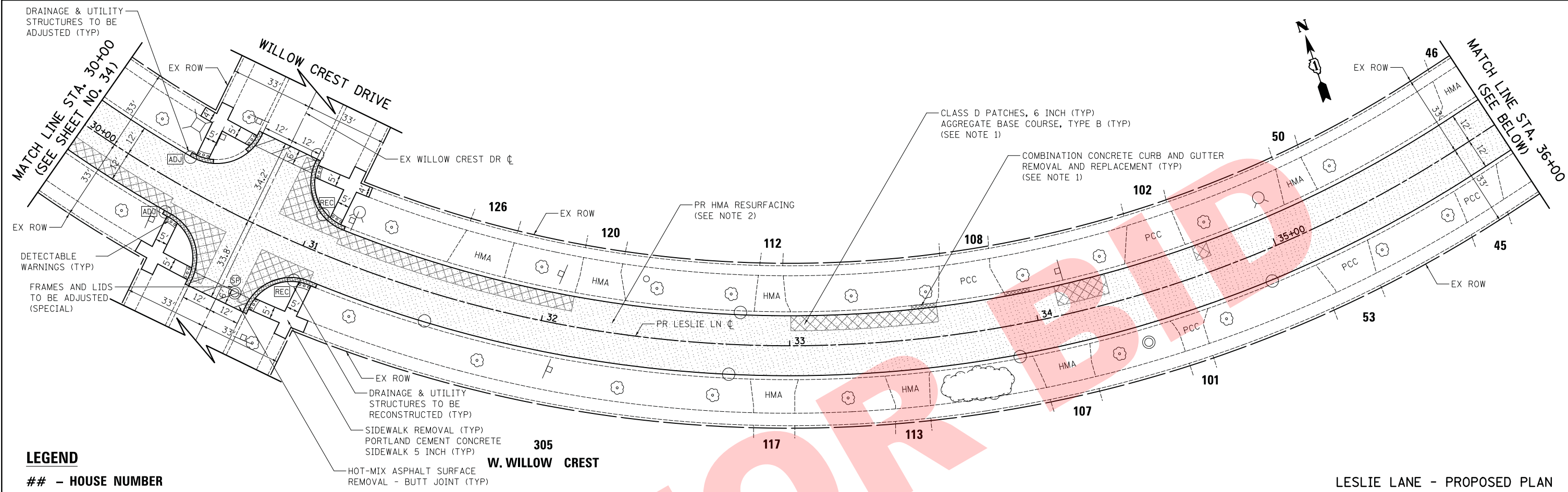

LEGEND

- HOUSE NUMBER

LESLIE LANE - PROPOSED PLAN

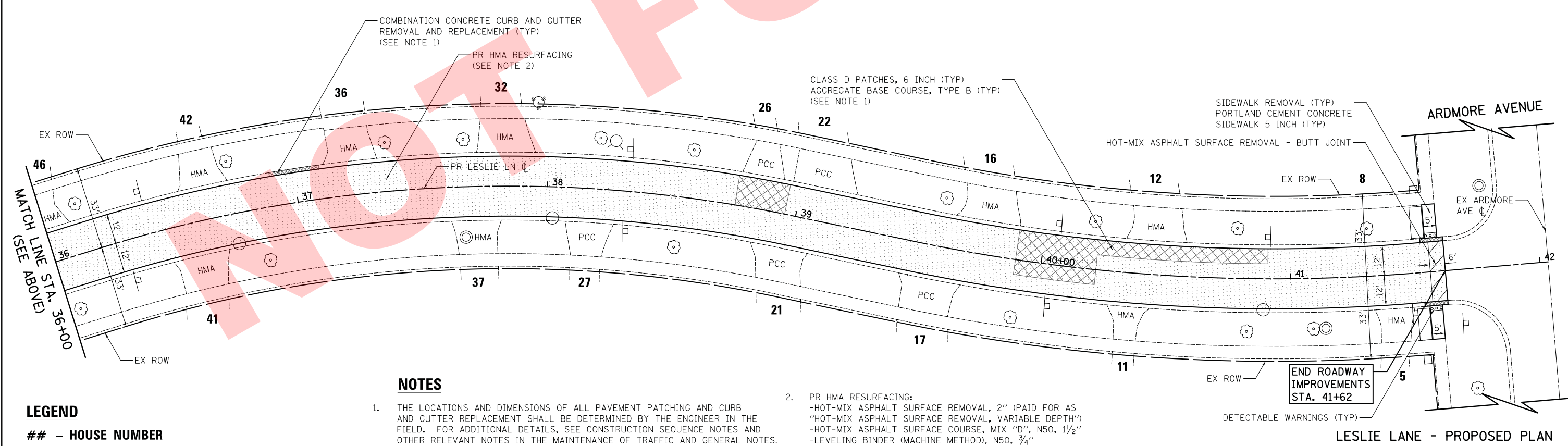

NOTES

1. THE LOCATIONS AND DIMENSIONS OF ALL PAVEMENT PATCHING AND CURB AND GUTTER REPLACEMENT SHALL BE DETERMINED BY THE ENGINEER IN THE FIELD. FOR ADDITIONAL DETAILS, SEE CONSTRUCTION SEQUENCE NOTES AND OTHER RELEVANT NOTES IN THE MAINTENANCE OF TRAFFIC AND GENERAL NOTES.
2. PR HMA RESURFACING:
 -HOT-MIX ASPHALT SURFACE REMOVAL, 2" (PAID FOR AS "HOT-MIX ASPHALT SURFACE REMOVAL, VARIABLE DEPTH")
 -HOT-MIX ASPHALT SURFACE COURSE, MIX "D", N50, 1/2"
 -LEVELING BINDER (MACHINE METHOD), N50, 3/4"

LEGEND

- HOUSE NUMBER

LESLIE LANE - PROPOSED PLAN

PLOT DRIVER = ...\\n:\p\dms\0314\ven_pdf.plt
 PEN TABLE = ...\\n:\p\tbl\cpl\ldot_ppd.ctb
 FILE NAME = ...3015-shr-pln-04.dgn



USER NAME = mjp	DESIGNED - MJP	REVISED -
	DRAWN - NEM	REVISED -
PLOT SCALE = 20.0000' / 1"	CHECKED - DNM	REVISED -
PLOT DATE = 4/14/2016	DATE - 04/15/16	REVISED -

VILLAGE OF VILLA PARK

**LESLIE LANE
PROPOSED ROADWAY PLAN**

SCALE: 1" = 20' SHEET OF SHEETS STA. 30+00 TO STA. 41+62

F.A. RTE.	SECTION	COUNTY	TOTAL SHEETS	SHEET NO.
		DUPAGE	62	35
CONTRACT NO.				
ILLINOIS FED. AID PROJECT				

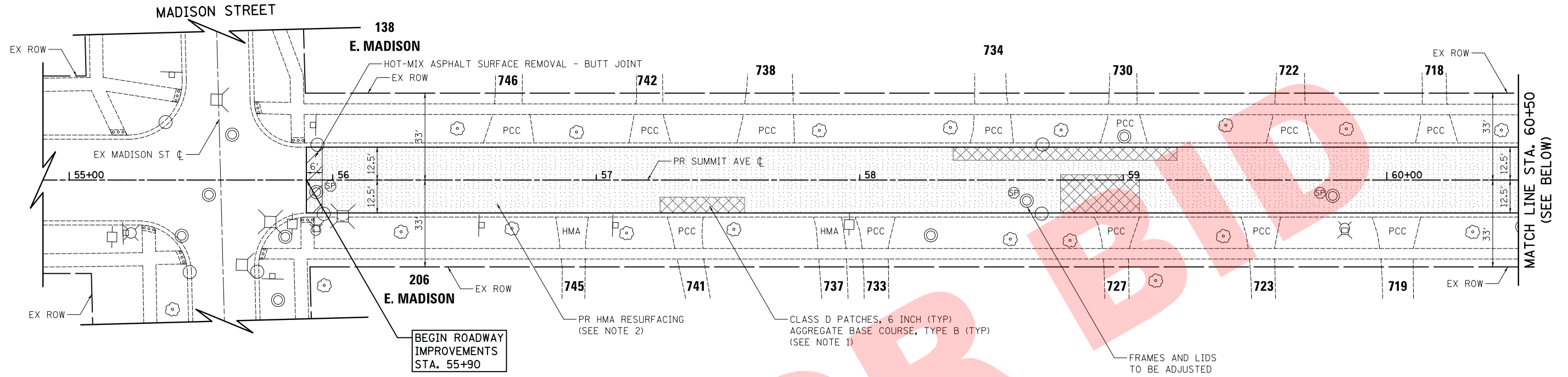
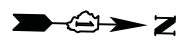

LEGEND

- HOUSE NUMBER

SUMMIT AVENUE - PROPOSED PLAN

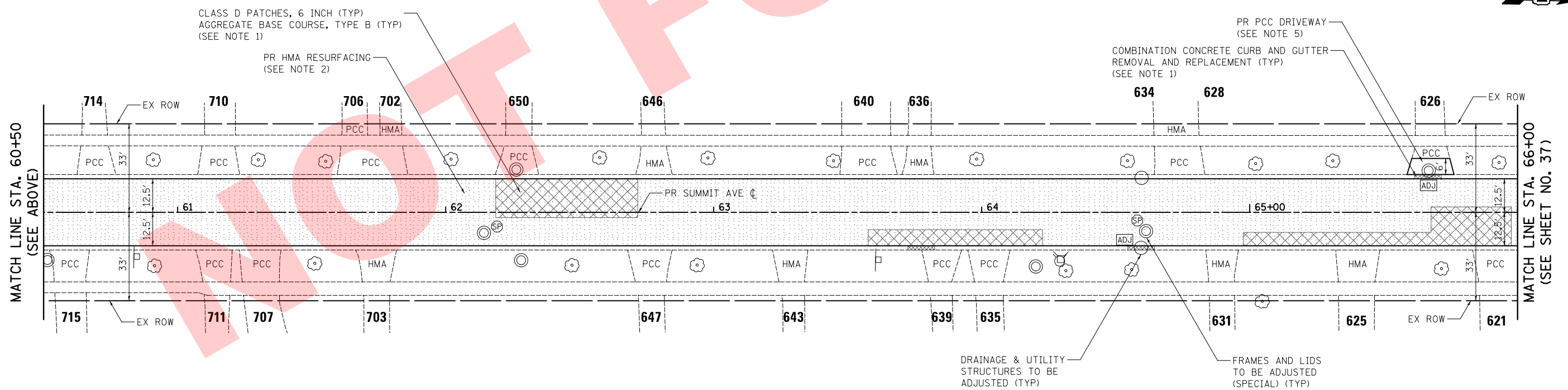

NOTES

1. THE LOCATIONS AND DIMENSIONS OF ALL PAVEMENT PATCHING AND CURB AND GUTTER REPLACEMENT SHALL BE DETERMINED BY THE ENGINEER IN THE FIELD. FOR ADDITIONAL DETAILS, SEE CONSTRUCTION SEQUENCE NOTES AND OTHER RELEVANT NOTES IN THE MAINTENANCE OF TRAFFIC AND GENERAL NOTES.
2. PR HMA RESURFACING:
-HOT-MIX ASPHALT SURFACE REMOVAL, 2" (PAID FOR AS "HOT-MIX ASPHALT SURFACE REMOVAL, VARIABLE DEPTH")
-HOT-MIX ASPHALT SURFACE COURSE, MIX "D", N50, 1/2"
-LEVELING BINDER (MACHINE METHOD), N50, 3/4"
5. PR PCC DRIVEWAY:
-DRIVEWAY PAVEMENT REMOVAL
-PORTLAND CEMENT CONCRETE DRIVEWAY PAVEMENT, 6 INCH
-AGGREGATE BASE COURSE, TYPE B 4"

LEGEND

- HOUSE NUMBER

SUMMIT AVENUE - PROPOSED PLAN

PLOT DRIVER = ...
PEN TABLE = ...
FILE NAME = ...



USER NAME = mjp	DESIGNED - MJP	REVISED -
	DRAWN - NEM	REVISED -
PLOT SCALE = 20.0000' / 1"	CHECKED - DNM	REVISED -
PLOT DATE = 4/14/2016	DATE - 04/15/16	REVISED -

VILLAGE OF VILLA PARK

**SUMMIT AVENUE
PROPOSED ROADWAY PLAN**

SCALE: 1" = 20' SHEET OF SHEETS STA. 55+90 TO STA. 66+00

F.A. RTE.	SECTION	COUNTY	TOTAL SHEETS	SHEET NO.
		DUPAGE	62	36
CONTRACT NO.				
ILLINOIS FED. AID PROJECT				

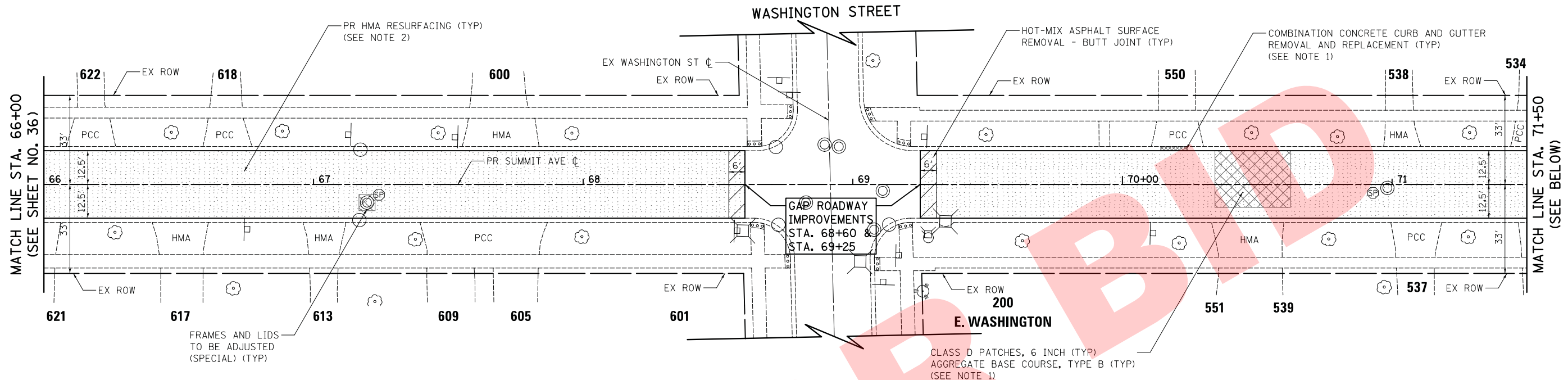
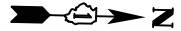

LEGEND

- HOUSE NUMBER

SUMMIT AVENUE - PROPOSED PLAN

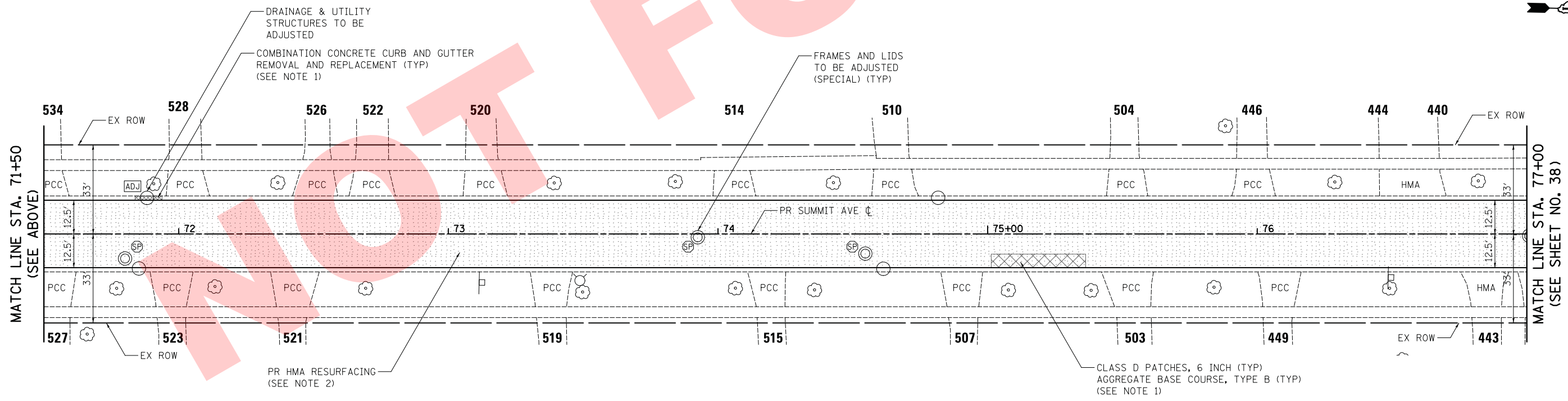

LEGEND

- HOUSE NUMBER

NOTES

1. THE LOCATIONS AND DIMENSIONS OF ALL PAVEMENT PATCHING AND CURB AND GUTTER REPLACEMENT SHALL BE DETERMINED BY THE ENGINEER IN THE FIELD. FOR ADDITIONAL DETAILS, SEE CONSTRUCTION SEQUENCE NOTES AND OTHER RELEVANT NOTES IN THE MAINTENANCE OF TRAFFIC AND GENERAL NOTES.
2. PR HMA RESURFACING:
 -HOT-MIX ASPHALT SURFACE REMOVAL, 2" (PAID FOR AS "HOT-MIX ASPHALT SURFACE REMOVAL, VARIABLE DEPTH")
 -HOT-MIX ASPHALT SURFACE COURSE, MIX "D", N50, 1/2"
 -LEVELING BINDER (MACHINE METHOD), N50, 3/4"

SUMMIT AVENUE - PROPOSED PLAN

PLOT DRIVER = ...\\n:\p\dms\0314\ven_pdf.plt
 PEN TABLE = ...\\pemb\cpl\ldot_ppducltbl
 FILE NAME = ...3015-shr-pla-06.dgn



USER NAME = mjp	DESIGNED - MJP	REVISED -
PLOT SCALE = 20.0000' / 1"	DRAWN - NEM	REVISED -
PLOT DATE = 4/14/2016	CHECKED - DNM	REVISED -
	DATE - 04/15/16	REVISED -

VILLAGE OF VILLA PARK

**SUMMIT AVENUE
PROPOSED ROADWAY PLAN**

SCALE: 1" = 20' SHEET OF SHEETS STA. 66+00 TO STA. 77+00

F.A. RTE.	SECTION	COUNTY	TOTAL SHEETS	SHEET NO.
		DUPAGE	62	37
CONTRACT NO.				
ILLINOIS FED. AID PROJECT				

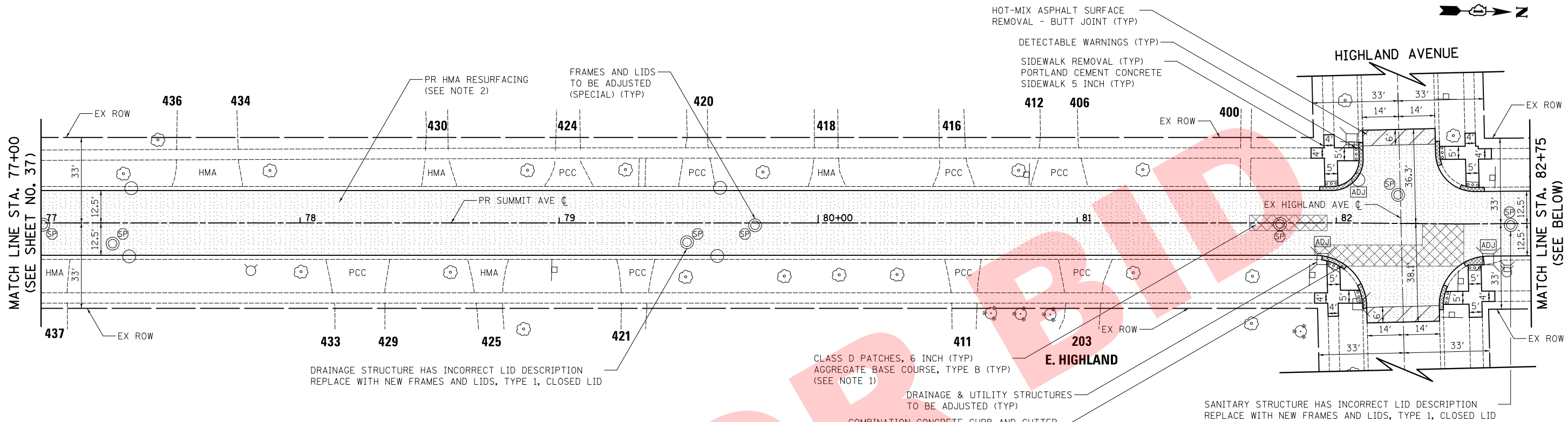

SUMMIT AVENUE - PROPOSED PLAN

LEGEND

- HOUSE NUMBER

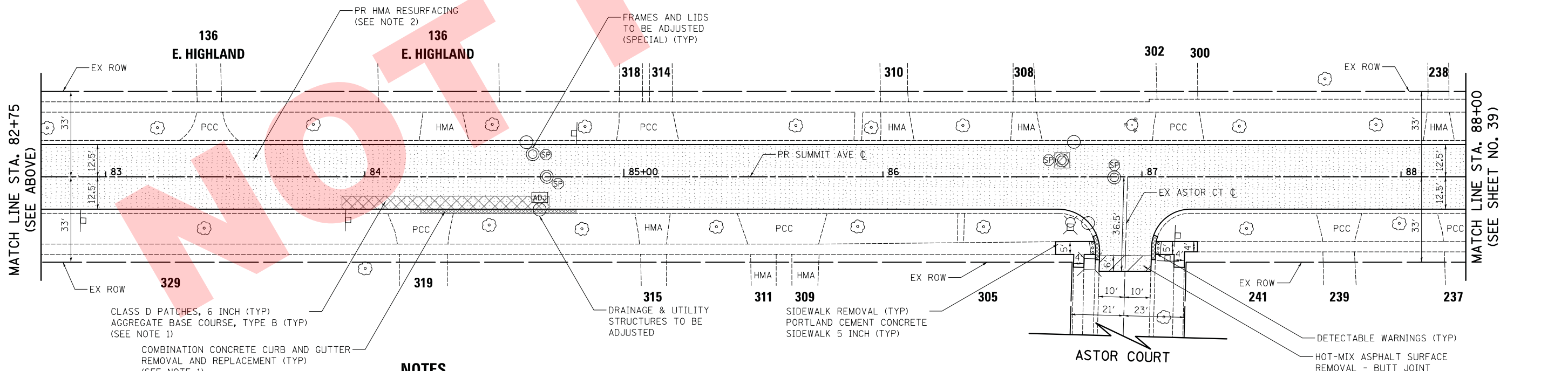

SUMMIT AVENUE - PROPOSED PLAN

NOTES

1. THE LOCATIONS AND DIMENSIONS OF ALL PAVEMENT PATCHING AND CURB AND GUTTER REPLACEMENT SHALL BE DETERMINED BY THE ENGINEER IN THE FIELD. FOR ADDITIONAL DETAILS, SEE CONSTRUCTION SEQUENCE NOTES AND OTHER RELEVANT NOTES IN THE MAINTENANCE OF TRAFFIC AND GENERAL NOTES.
2. PR HMA RESURFACING:
 -HOT-MIX ASPHALT SURFACE REMOVAL, 2" (PAID FOR AS "HOT-MIX ASPHALT SURFACE REMOVAL, VARIABLE DEPTH")
 -HOT-MIX ASPHALT SURFACE COURSE, MIX "D", N50, 1 1/2"
 -LEVELING BINDER (MACHINE METHOD), N50, 3/4"

LEGEND

- HOUSE NUMBER

PLOT DRIVER = ...
 PEN TABLE = ...
 FILE NAME = ...



USER NAME = mjp	DESIGNED - MJP	REVISED -
PLOT SCALE = 20.0000' / 1"	DRAWN - NEM	REVISED -
PLOT DATE = 4/14/2016	CHECKED - DNM	REVISED -
	DATE - 04/15/16	REVISED -

VILLAGE OF VILLA PARK

**SUMMIT AVENUE
 PROPOSED ROADWAY PLAN**

SCALE: 1" = 20' SHEET OF SHEETS STA. 77+00 TO STA. 88+00

F.A. RTE.	SECTION	COUNTY	TOTAL SHEETS	SHEET NO.
			62	38
CONTRACT NO.				
ILLINOIS FED. AID PROJECT				

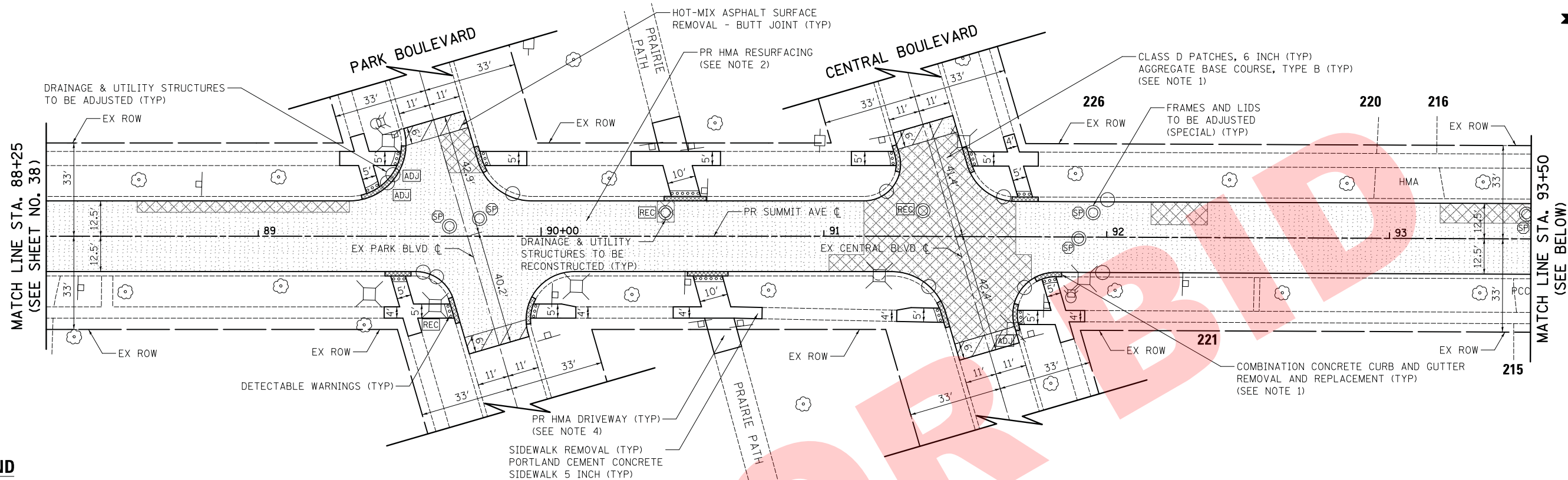

LEGEND

- HOUSE NUMBER

SUMMIT AVENUE - PROPOSED PLAN

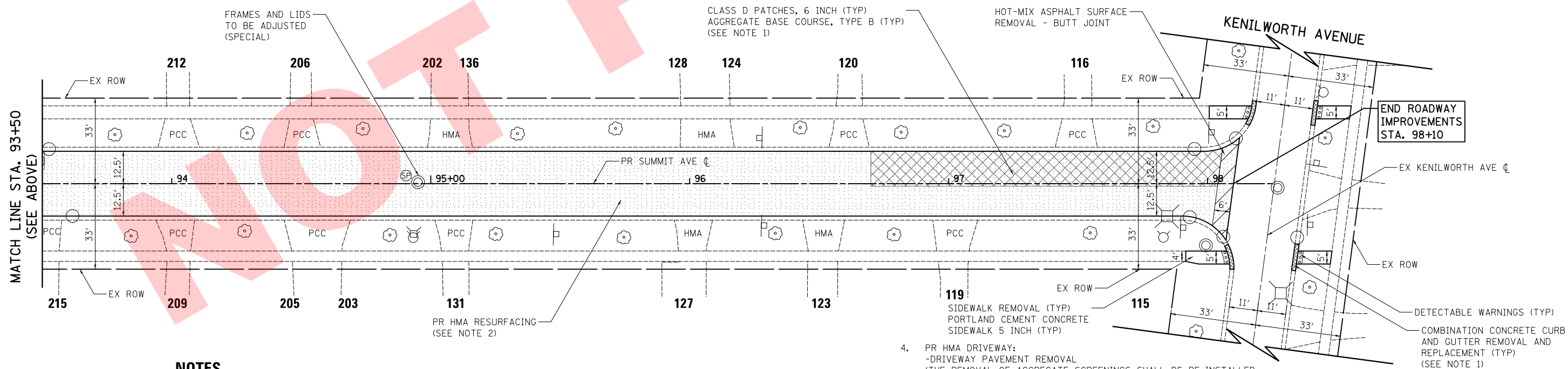

NOTES

- THE LOCATIONS AND DIMENSIONS OF ALL PAVEMENT PATCHING AND CURB AND GUTTER REPLACEMENT SHALL BE DETERMINED BY THE ENGINEER IN THE FIELD. FOR ADDITIONAL DETAILS, SEE CONSTRUCTION SEQUENCE NOTES AND OTHER RELEVANT NOTES IN THE MAINTENANCE OF TRAFFIC AND GENERAL NOTES.
- PR HMA RESURFACING:
 - HOT-MIX ASPHALT SURFACE REMOVAL, 2" (PAID FOR AS "HOT-MIX ASPHALT SURFACE REMOVAL, VARIABLE DEPTH")
 - HOT-MIX ASPHALT SURFACE COURSE, MIX "D", N50, 1 1/2"
 - LEVELING BINDER (MACHINE METHOD), N50, 3/4"
- PR HMA DRIVEWAY:
 - DRIVEWAY PAVEMENT REMOVAL (THE REMOVAL OF AGGREGATE SCREENINGS SHALL BE RE-INSTALLED AT THE TRANSITION BETWEEN THE PR HMA PATH AND THE EX AGGREGATE PATH TO PROVIDE A SMOOTH PATH TRANSITION. THIS WORK WILL BE INCLUDED IN THE COST OF THIS ITEM.)
 - HOT-MIX ASPHALT DRIVEWAY PAVEMENT, 4"
 - AGGREGATE BASE COURSE, TYPE B 6"

LEGEND

- HOUSE NUMBER

SUMMIT AVENUE - PROPOSED PLAN

PLOT DRIVER = ...\\n:\p\dms\0314\ven_pdr.pdf.plt
 PEN TABLE = ...\\pennb\cml\dot_ppd\tbl1
 FILE NAME = ...3815-shr-pla-08.dgn



USER NAME = mjp	DESIGNED - MJP	REVISED -
	DRAWN - NEM	REVISED -
PLOT SCALE = 20.0000' / 1"	CHECKED - DNM	REVISED -
PLOT DATE = 4/14/2016	DATE - 04/15/16	REVISED -

VILLAGE OF VILLA PARK

**SUMMIT AVENUE
PROPOSED ROADWAY PLAN**

SCALE: 1" = 20' SHEET OF SHEETS STA. 88+00 TO STA. 98+10

F.A. RTE.	SECTION	COUNTY	TOTAL SHEETS	SHEET NO.
		DUPAGE	62	39
CONTRACT NO.				
ILLINOIS FED. AID PROJECT				

CONSTRUCTION SEQUENCE

THIS CONSTRUCTION SEQUENCE WAS DEVELOPED TO MINIMIZE DISRUPTION OF ACCESS TO HOMEOWNERS AND BUSINESSES DRIVEWAYS. THIS CONSTRUCTION SEQUENCE SHALL BE FOLLOWED UNLESS ALTERNATE SEQUENCE IS APPROVED BY VILLAGE.

ALL STREETS

- CALL JULIE
- PERFORM PRECONSTRUCTION VIDEO TAPING
- SET UP EROSION AND SEDIMENT CONTROL MEASURES
- SET UP TRAFFIC CONTROL PER APPLICABLE IDOT STANDARDS

SUMMIT AVENUE, LESLIE LANE, AND MONROE STREET

1. COMPLETE UTILITY AND DRAINAGE WORK
2. REMOVE AND REPLACE CURB AND GUTTER AS DIRECTED BY THE ENGINEER (ALL CURB AND GUTTER REPLACEMENT ON MONROE STREET)
3. COMPLETE DRIVEWAY APRON AND SIDEWALK IMPROVEMENTS
4. REMOVE UTILITY FRAMES FROM PAVEMENT SURFACE
5. REMOVE HMA PAVEMENT SURFACE
6. PATCH PAVEMENT BASE AS DIRECTED BY THE ENGINEER
7. INSTALL HMA LEVELING BINDER
8. LANDSCAPE
9. RE-INSTALL UTILITY FRAMES
10. INSTALL HMA SURFACE COURSE
11. INSTALL PAVEMENT MARKINGS

HOME AVENUE

1. COMPLETE UTILITY AND DRAINAGE WORK
2. REMOVE PAVEMENT (RECON SECTION) AND CURB AND GUTTER
3. INSTALL AGGREGATE BASE AND GEOGRID (RECON SECTION)
4. INSTALL CURB AND GUTTER
5. INSTALL HMA BINDER COURSE (RECON SECTION)
6. REMOVE UTILITY FRAMES FROM PAVEMENT SURFACE (RESURFACING SECTION)
7. REMOVE HMA PAVEMENT SURFACE (RESURFACING SECTION)
8. PATCH PAVEMENT BASE AS DIRECTED BY ENGINEER (RESURFACING SECTION)
9. INSTALL HMA LEVELING BINDER (RESURFACING SECTION)
10. RE-INSTALL UTILITY FRAMES (RESURFACING SECTION)
11. REMOVE AND REPLACE DRIVEWAY APRONS
12. LANDSCAPE
13. INSTALL HMA SURFACE COURSE
14. INSTALL PAVEMENT MARKINGS

ORCHARD HILL COURT

1. REMOVE AND REPLACE ALL CURB AND GUTTER
2. REMOVE AND REPLACE DRIVEWAY APRONS
3. PATCH CONCRETE PAVEMENT AS DIRECTED BY ENGINEER
4. INSTALL HMA LEVELING BINDER
5. LANDSCAPE
6. INSTALL HMA SURFACE COURSE
7. INSTALL PAVEMENT MARKINGS

HARRISON STREET

1. COMPLETE UTILITY AND DRAINAGE WORK
2. SAW CUT MONOLITHIC PAVEMENT TO SEPARATE CURB AND GUTTER
3. REMOVE AND REPLACE CURB AND GUTTER AS DIRECTED BY THE ENGINEER
4. REMOVE UTILITY FRAMES FROM PAVEMENT SURFACE
5. REMOVE HMA SURFACE AND GRIND CONCRETE SURFACE
6. PATCH PAVEMENT BASE AS DIRECTED BY THE ENGINEER
7. COMPLETE RECONSTRUCTION SECTION UP TO BINDER COURSE
8. INSTALL HMA LEVELING BINDER
9. LANDSCAPE
10. RE-INSTALL UTILITY FRAMES
11. INSTALL HMA SURFACE COURSE
12. INSTALL PAVEMENT MARKINGS

PRINCETON AVENUE

1. REMOVE EXISTING PAVEMENT
2. AGGREGATE BASE REPAIR AS DIRECTED BY THE ENGINEER
3. PREPARATION OF BASE
4. INSTALL HMA BINDER COURSE
5. LANDSCAPE
6. INSTALL HMA SURFACE COURSE
7. REPLACE DRIVEWAY APRONS

WILDFIRE DRIVE

1. PATCH EXISTING PAVEMENT AS DIRECTED BY THE ENGINEER

ARDMORE AVENUE

1. REMOVE EXISTING AND INSTALL NEW PAVEMENT MARKINGS

MAINTENANCE OF TRAFFIC GENERAL NOTES

1. DRUMS EQUIPPED WITH ONE-WAY FLASHING LIGHTS WILL BE REQUIRED AT ALL OPEN TRENCHES, EXCAVATIONS, OPEN OR EXPOSED SEWER STRUCTURES, AND AT ANY OTHER LOCATIONS DESIGNATED BY THE ENGINEER OR LAW ENFORCEMENT AGENCIES. BARRICADES SHALL BE PLACED AT 50' CENTERS ALONG TANGENTS, 20' CENTERS ALONG TAPERS, AND 10' CENTERS IN CURVES AND RADII.
2. "FRESH OIL" SIGNS (W21-2-4848) WITH DATE SIGNS SHALL BE ERECTED 48 HOURS PRIOR TO PRIMING ALONG ALL STREETS. THE COST OF THESE SIGNS SHALL BE INCLUDED IN THE PAY ITEM "TRAFFIC CONTROL AND PROTECTION, (SPECIAL)".
3. THE COST OF SUPPLYING, ERECTING, AND MAINTAINING BARRICADES, DRUMS, WARNING LIGHTS, AND SIGNS SHALL BE INCLUDED IN THE COST OF "TRAFFIC CONTROL AND PROTECTION, (SPECIAL)".
4. ONLY ONE-HALF (1/2) OF A STREET CAN BE PATCHED AT A TIME.
5. THE CURB AND GUTTER CAN ONLY BE REPLACED ON ONE SIDE OF THE STREET AT A TIME.

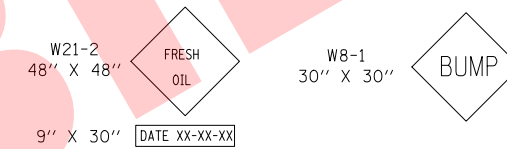

TO BE PLACED AS DIRECTED BY THE ENGINEER

DRIVEWAY ACCESS NOTES

MAINTAINING ACCESS TO DRIVEWAYS IS OF THE UTMOST IMPORTANCE TO THE VILLAGE. THE CONTRACTOR SHALL BE RESPONSIBLE FOR SUB-STAGING THE CONSTRUCTION OF DRIVEWAYS. THE CONTRACTOR SHALL FOLLOW THESE PROCEDURES TO ENSURE PROPER DRIVEWAY ACCESS:

1. THE CONTRACTOR SHALL WORK WITH ADJACENT BUSINESS AND RESIDENTIAL OWNERS TO DETERMINE DRIVEWAY RECONSTRUCTION SCHEDULING. ALL DRIVEWAY CLOSURES SHALL BE APPROVED BY THE ENGINEER.
2. TEMPORARY DRIVES SHALL BE CONSTRUCTED TO THE WIDTH AND AT LOCATIONS DETERMINED BY THE ENGINEER. THE COST OF PLACING, MAINTAINING, AND REMOVING TEMPORARY DRIVES ON HOME AVENUE SHALL BE INCLUDED IN THE COST OF "TEMPORARY ACCESS (DRIVEWAY ENTRANCE)". ALL OTHER LOCATIONS REQUIRING TEMPORARY DRIVES WILL BE INCLUDED IN THE COST OF "AGGREGATE FOR TEMPORARY ACCESS".
3. THE TEMPORARY DRIVEWAYS SHALL NOT BE REMOVED FOR THE PLACEMENT OF THE AGGREGATE BASE COURSE OR HOT-MIX ASPHALT BINDER COURSE UNTIL THE EVENING PRIOR TO THEIR PLACEMENT. WHEN DIRECTED BY THE ENGINEER, THE CONTRACTOR SHALL NOT REMOVE THE TEMPORARY ACCESS UNTIL THE MORNING OF THE PAVING OPERATIONS. REPLACEMENT OF THE TEMPORARY ACCESS UPON COMPLETION OF THE PLACEMENT OF THE AGGREGATE BASE COURSE OR PAVING OPERATION SHALL BE INCLUDED IN THE COST OF "TEMPORARY ACCESS (DRIVEWAY ENTRANCE)".
4. THE CONTRACTOR SHALL, WHERE WIDTH ALLOWS, STAGE CONSTRUCT CURB AND GUTTER AND DRIVEWAYS, AS DIRECTED BY THE ENGINEER. ALL EFFORTS REQUIRED TO SUB-STAGE DRIVEWAY CONSTRUCTION AND MAINTAIN ACCESS TO DRIVEWAY SHALL BE INCLUDED IN THE COST OF "TRAFFIC CONTROL AND PROTECTION, (SPECIAL)".

SIDEWALK MAINTENANCE NOTE

1. THE SIDEWALK ON ONE SIDE OF THE STREET MUST REMAIN OPEN AND ACCESSIBLE AT ALL TIMES. UTILITY RELOCATIONS SHALL BE COORDINATED WITH THE ENGINEER AND CONTRACTOR TO ENSURE ONE SIDEWALK REMAINS OPEN. SIGNING DIRECTING PEDESTRIANS TO THE OPEN SIDEWALK SHALL BE IN ACCORDANCE WITH IDOT HIGHWAY STANDARD 701801-06. THE WORK REQUIRED TO COMPLY WITH THESE REQUIREMENTS SHALL BE INCLUDED IN THE COST OF "TRAFFIC CONTROL AND PROTECTION, (SPECIAL)".
2. TEMPORARY AGGREGATE REQUIRED TO MAINTAIN PEDESTRIAN ACCESS ACROSS THE WORKZONE SHALL BE INCLUDED IN THE COST OF "TEMPORARY ACCESS (ROAD)".

PLOT DRIVER = ...\\n:\p\dms\0314\con_pdf\p1.t
PEN TABLE = ...\\pemb\con_idot_general.tbl
FILE NAME = ...\\3015-shr-astgng\01.dgn



USER NAME = mjp	DESIGNED - DNM	REVISED -
	DRAWN - NEM	REVISED -
PLOT SCALE = 1.0000' / 1in.	CHECKED - DNM	REVISED -
PLOT DATE = 4/14/2016	DATE - 04/15/16	REVISED -

VILLAGE OF VILLA PARK

2016 STREET IMPROVEMENTS MAINTENANCE OF TRAFFIC - GENERAL NOTES

SCALE: N.T.S. SHEET OF SHEETS STA. TO STA.

F.A. RTE.	SECTION	COUNTY	TOTAL SHEETS	SHEET NO.
		DUPAGE	62	40
CONTRACT NO.				
ILLINOIS FED. AID PROJECT				

ROAD CLOSURE GENERAL NOTES

1. THE ENGINEER SHALL BE NOTIFIED IN WRITING AT LEAST 7 CALENDAR DAYS PRIOR TO THE DAY THE ROAD CLOSURE IS TO BE IN EFFECT. THE CONTRACTOR SHALL CONTACT THE APPROPRIATE LOCAL AGENCIES AND INTERESTED PARTIES.
2. ALL SIGNING SHALL BE IN ACCORDANCE WITH THE APPLICABLE PROVISIONS OF THE STANDARD SPECIFICATIONS, THE DETAILS IN THESE PLANS, THE LATEST EDITION OF THE STATE OF ILLINOIS "MANUAL ON UNIFORM TRAFFIC CONTROL DEVICES," AND AS DIRECTED BY THE ENGINEER.
3. THE SIZES OF ALL SIGNS NOT SPECIFIED IN THESE PLANS SHALL BE AS REQUIRED BY THE FHWA "MANUAL ON UNIFORM TRAFFIC CONTROL DEVICES" AND ILLINOIS SUPPLEMENT. ADDITIONAL SIGNING AND/OR BARRICADES DEEMED NECESSARY BY THE ENGINEER SHALL BE PROVIDED AND INSTALLED. THIS WORK WILL NOT BE PAID FOR SEPARATELY BUT SHALL BE INCLUDED IN THE COST OF "TRAFFIC CONTROL AND PROTECTION, (SPECIAL)".
4. THE CONTRACTOR SHALL PROVIDE THE ENGINEER WITH THE NAMES AND PHONE NUMBERS OF HIS REPRESENTATIVES ON THE CONSTRUCTION SITE, AND HIS REPRESENTATIVE RESPONSIBLE FOR THE ROAD SIGNING, SEVEN CALENDAR DAYS PRIOR TO THE START OF WORK.
5. THE CONTRACTOR SHALL BE RESPONSIBLE FOR THE FIELD LOCATION OF ALL ROAD CLOSURE AND CONSTRUCTION SIGNING. THE CONTRACTOR MAY REQUEST THE ENGINEER TO FIELD VERIFY THE POSITIONS OF ANY SIGNS.
6. ACTUAL LOCATIONS FOR SIGNING SHOWN ON THE ROAD CLOSURE PLANS MAY BE ADJUSTED TO FIT FIELD CONDITIONS.
7. ALL EXISTING SIGNING THAT IS NOT APPLICABLE WHILE THE ROAD CLOSURE IS IN EFFECT SHALL BE COMPLETELY COVERED BY THE CONTRACTOR IN A MANNER MEETING THE APPROVAL OF THE ENGINEER.
8. ALL ROAD CLOSURE SIGNING SHALL BE POST MOUNTED.
9. ALL ROAD CLOSURE SIGNING EXCEPT REGULATORY SIGNS SHALL HAVE BLACK LEGENDS ON FLUORESCENT ORANGE SHEETING AND STANDARD BLACK BORDERS. THE FLUORESCENT ORANGE REFLECTIVE SHEETING SHALL MEET THE REQUIREMENTS OF ARTICLE 1106.01 OF THE STANDARD SPECIFICATIONS. ALL ROAD CLOSURE SIGNING SHALL BE NEW OR IN LIKE-NEW CONDITION. THE ENGINEER SHALL BE THE SOLE JUDGE OF THE CONDITION OF THE SIGNS.
10. THE ROAD NAME SIGN SHALL BE A BLACK LEGEND ON ORANGE REFLECTIVE SHEETING. THE SIGN BLANK SHALL BE VARIABLE WITH DESIGN SERIES B LETTERS. THE CAPITAL LETTERS SHALL BE 4 INCHES.
11. AT A MINIMUM, ALL AMBER FLASHING LIGHTS THAT ARE REQUIRED FOR THE ROAD CLOSURE SIGNING SHALL MEET THE REQUIREMENTS FOR TYPE A-LOW INTENSITY FLASHING LIGHTS IN ARTICLE 1106.02 OF THE STANDARD SPECIFICATIONS. ALL LIGHTS SHALL OPERATE DURING HOURS OF DARKNESS. ONLY LIGHTS THAT HAVE BEEN APPROVED BY THE ILLINOIS DEPARTMENT OF TRANSPORTATION SHALL BE USED.
12. THE CONTRACTOR SHALL BE RESPONSIBLE FOR ENSURING THAT ALL BARRICADES, SIGNS, LIGHTS AND OTHER DEVICES INSTALLED BY HIM ARE IN PLACE AND OPERATING 24 HOURS EACH DAY, INCLUDING SUNDAYS AND HOLIDAYS.
13. TYPE III BARRICADES SHALL BE USED AT POINTS OF CLOSURE TO THRU TRAFFIC ONLY AND SHALL NOT EXCEED 8 FEET IN WIDTH EACH FOR A SINGLE APPROACH LANE. ALL BARRICADES AT THESE LOCATIONS SHALL HAVE REFLECTORIZED STRIPING ON THE BACK SIDES OF THE BARRICADES.
14. CONSTRUCTION EQUIPMENT SHALL NOT BE PARKED IMMEDIATELY BEHIND THE TYPE III BARRICADES DURING NON-WORKING HOURS. IN ANY EVENT, ARTICLE 701.11 OF THE STANDARD SPECIFICATIONS SHALL APPLY.
15. DURING NON-WORKING HOURS THE CONTRACTOR SHALL PROVIDE A MEANS TO RESTRAIN THE TYPE III BARRICADES FROM EASY MOVEMENT BY VANDALS. THE CHOSEN METHOD SHALL BE APPROVED BY THE ENGINEER.
16. THE CONTRACTOR SHALL BE RESPONSIBLE FOR MAINTAINING THE VISIBILITY OF ALL ROAD CLOSURE AND CONSTRUCTION SIGNS, INCLUDING BRUSHING BACK VEGETATION IF DEEMED NECESSARY BY THE ENGINEER.
17. THE ENGINEER SHALL BE NOTIFIED AT LEAST 24 HOURS BEFORE THE ROAD IS TO BE REOPENED TO TRAFFIC. THE CONTRACTOR WILL CONTACT THE APPROPRIATE LOCAL AGENCIES AND INTERESTED PARTIES.
18. THE COST OF THE ROAD CLOSURE AS DEFINED ON THE MAINTENANCE OF TRAFFIC - ROAD CLOSURE PLAN SHALL BE INCLUDED IN THE LUMP SUM PRICE FOR "TRAFFIC CONTROL AND PROTECTION, (SPECIAL)".

SIGN NO.

SIGN TYPE

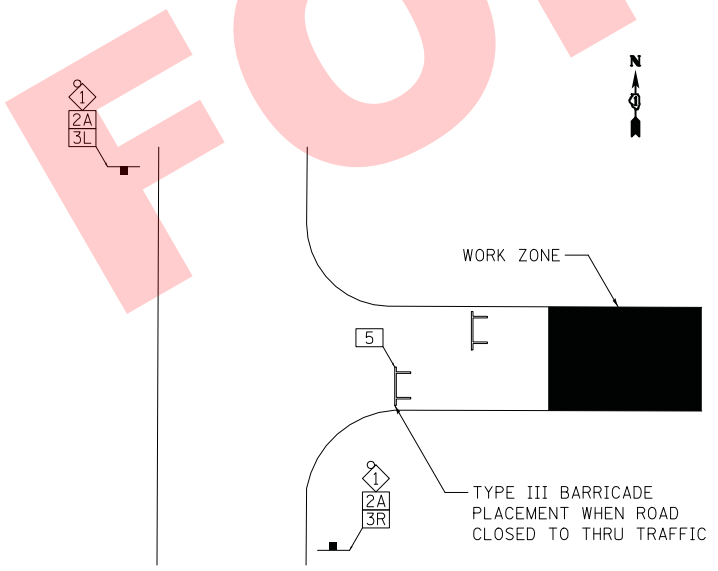
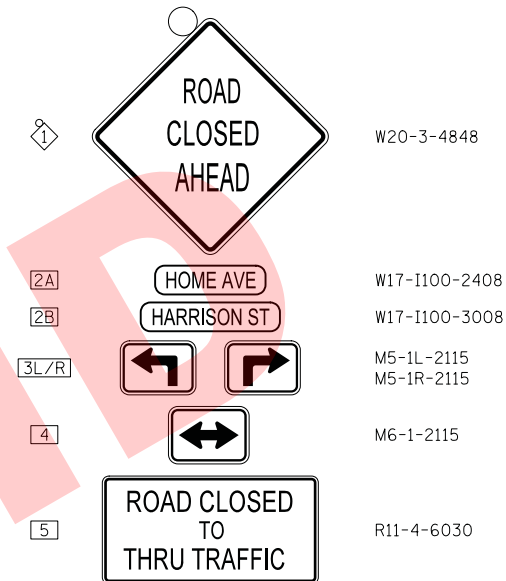



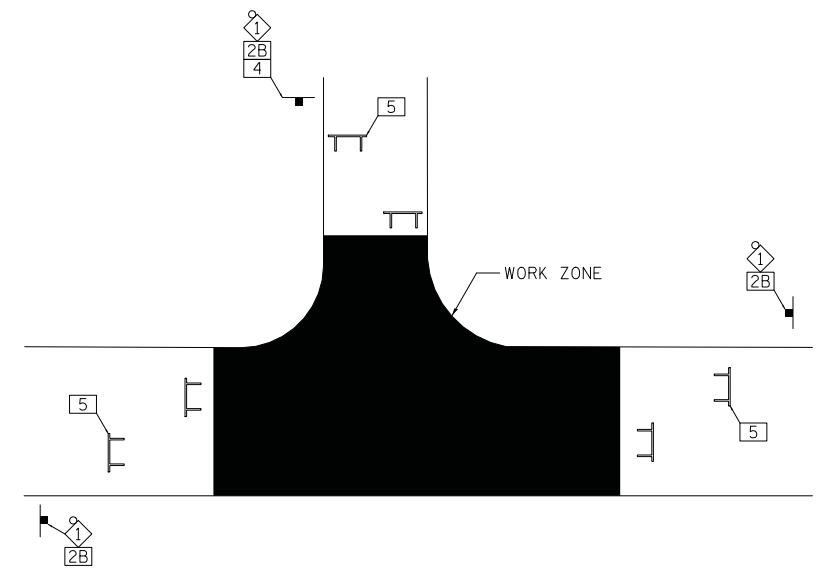

ROAD CLOSURE DETAIL - HOME AVENUE



ROAD CLOSURE DETAIL - HARRISON STREET

LEGEND

-  CONSTRUCTION WORK ZONE
-  PROPOSED TRAFFIC SIGN
-  TYPE III BARRICADE WITH FLASHING LIGHTS
-  CONSTRUCTION WARNING SIGN WITH AMBER FLASHING LIGHT

PLOT DRIVER = ...\\n:\p\dma\0314\con_pdf.plt
 PEN TABLE = ...\\n:\p\dma\0314\con_pdf.tbl
 FILE NAME = ...\\n:\p\dma\0314\con_pdf.dgn



USER NAME = mjp	DESIGNED - DNM	REVISED -
	DRAWN - NEM	REVISED -
PLOT SCALE = 1:8000' / 1"	CHECKED - DNM	REVISED -
PLOT DATE = 4/14/2016	DATE - 04/15/16	REVISED -

VILLAGE OF VILLA PARK

**2016 STREET IMPROVEMENTS
MAINTENANCE OF TRAFFIC - ROAD CLOSURE DETAILS**

SCALE: N.T.S. SHEET OF SHEETS STA. TO STA.

F.A. RTE.	SECTION	COUNTY	TOTAL SHEETS	SHEET NO.
		DUPAGE	62	41
CONTRACT NO.				
ILLINOIS FED. AID PROJECT				

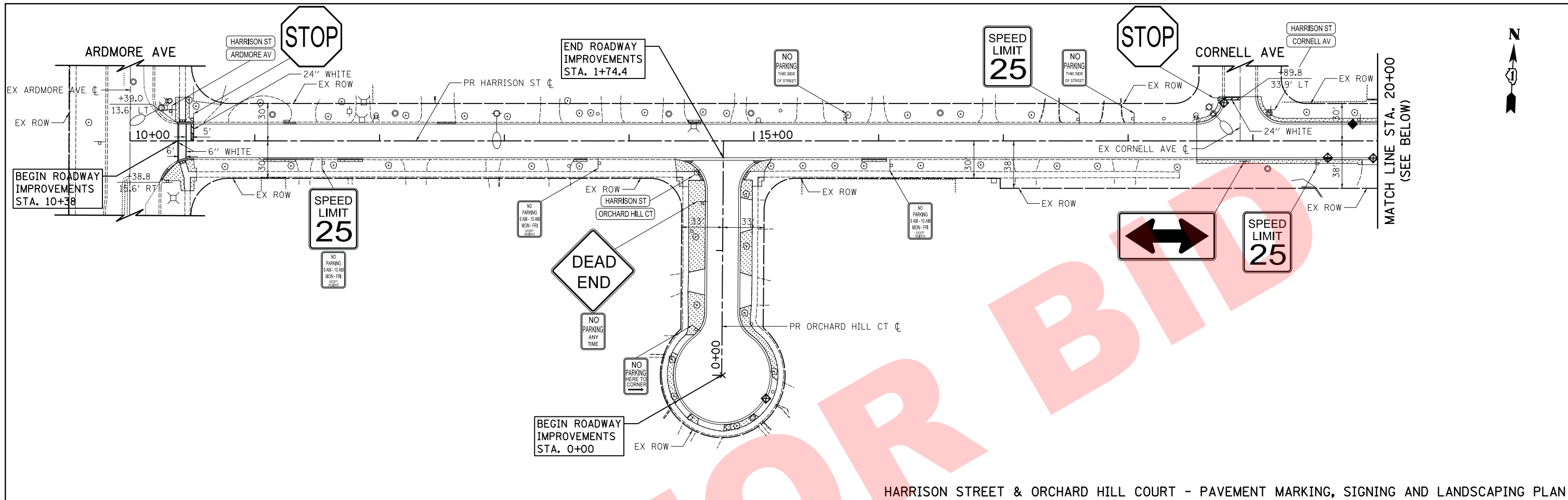

HARRISON STREET & ORCHARD HILL COURT - PAVEMENT MARKING, SIGNING AND LANDSCAPING PLAN

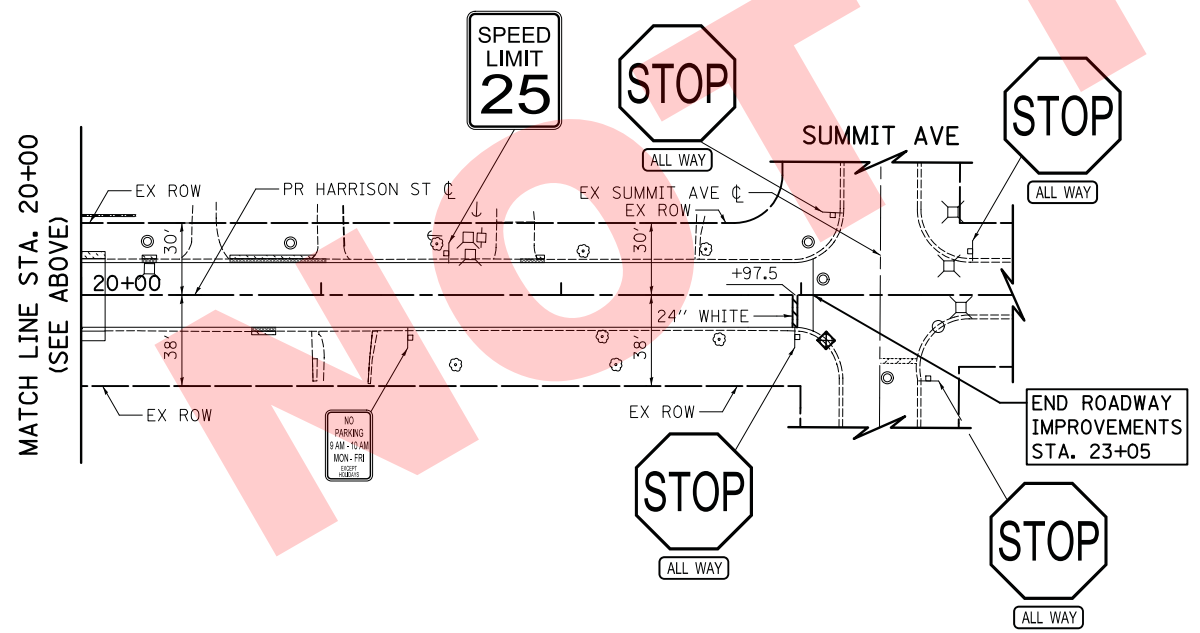

LEGEND

- TOPSOIL FURNISH AND PLACE, 4" SODDING
- INLET FILTERS
- RELOCATE SIGN PANEL ASSEMBLY, TYPE A OR B AND NEW TELESCOPING STEEL SIGN SUPPORT
- EX SIGN
- PR SIGN
- PR WHITE LETTERS AND SYMBOLS

NOTES

1. ALL SIGNS ARE EXISTING TO REMAIN UNLESS OTHERWISE NOTED.
2. ALL PERMANENT PAVEMENT MARKINGS SHALL BE THERMOPLASTIC UNLESS OTHERWISE NOTED.
3. DIMENSIONS TO PAVEMENT MARKINGS ARE TO THE CENTER OF A SINGLE LINE OR THE CENTER OF GAP FOR A DOUBLE LINE.
4. EXISTING PAVEMENT MARKINGS IN CONFLICT WITH PROPOSED MARKINGS SHALL BE REMOVED.

HARRISON STREET - PAVEMENT MARKING, SIGNING AND LANDSCAPING PLAN

PLOT DRIVER = ...\\n:\p\dms\0314\ven_pdf.plt
 PEN TABLE = ...\\pemb\cpl\ldot_general.tbl
 FILE NAME = ...3015-shr-pmk-landscp01.dgn



USER NAME = mjp	DESIGNED - DTE	REVISED -
	DRAWN - NEM	REVISED -
PLOT SCALE = 40.0000' / in.	CHECKED - DNM	REVISED -
PLOT DATE = 4/14/2016	DATE - 04/15/16	REVISED -

VILLAGE OF VILLA PARK

**HARRISON STREET AND ORCHARD HILL COURT
PAVEMENT MARKING, SIGNING AND LANDSCAPING PLAN**

SCALE: 1" = 40' SHEET OF SHEETS STA. TO STA.

F.A. RTE.	SECTION	COUNTY	TOTAL SHEETS	SHEET NO.
		DUPAGE	62	42
CONTRACT NO.				
ILLINOIS FED. AID PROJECT				

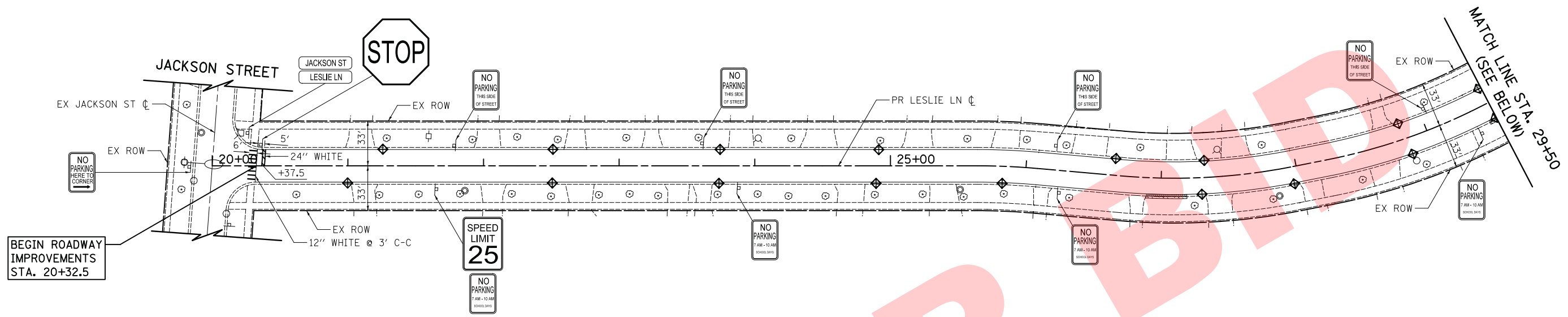
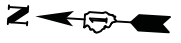

LESLIE LANE - PAVEMENT MARKING, SIGNING AND LANDSCAPING PLAN

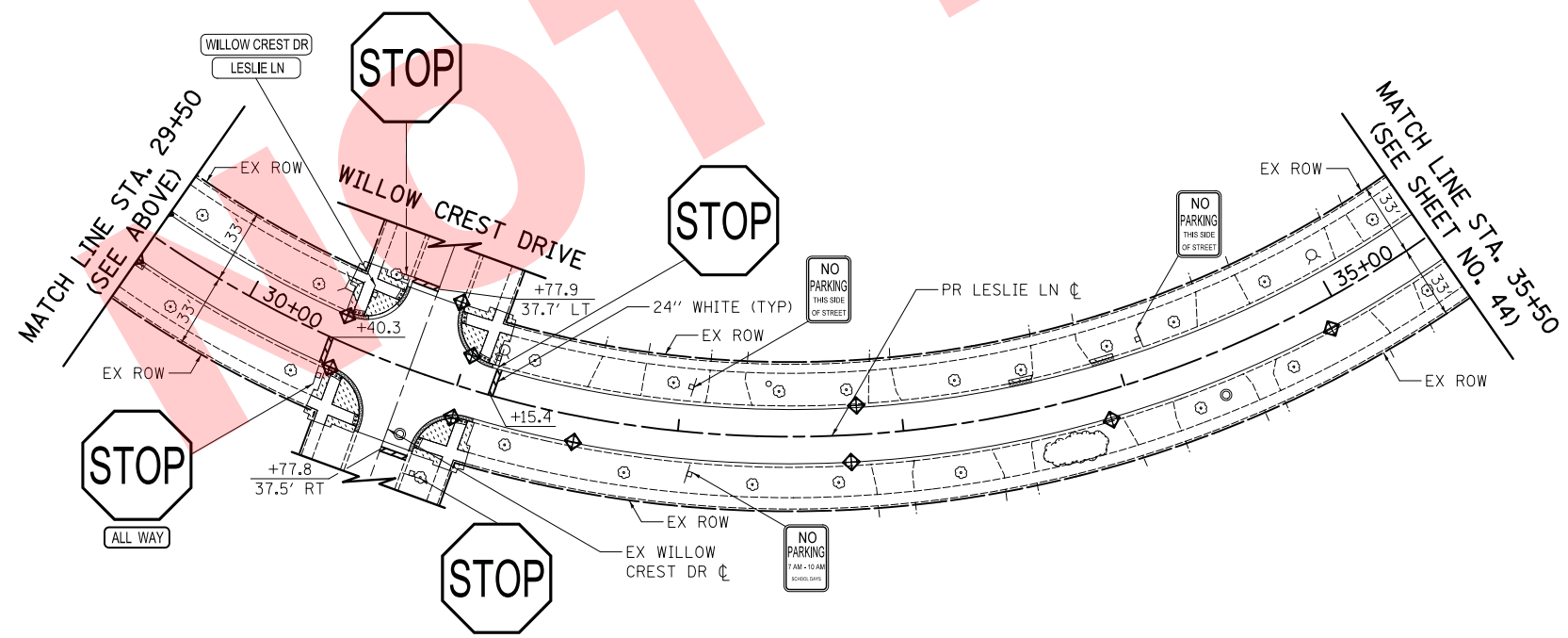

LEGEND

- TOPSOIL FURNISH AND PLACE, 4" SODDING
- INLET FILTERS
- REL RELOCATE SIGN PANEL ASSEMBLY, TYPE A OR B AND NEW TELESCOPING STEEL SIGN SUPPORT
- EX SIGN
- PR SIGN
- PR WHITE LETTERS AND SYMBOLS

NOTES

1. ALL SIGNS ARE EXISTING TO REMAIN UNLESS OTHERWISE NOTED.
2. ALL PERMANENT PAVEMENT MARKINGS SHALL BE THERMOPLASTIC UNLESS OTHERWISE NOTED.
3. DIMENSIONS TO PAVEMENT MARKINGS ARE TO THE CENTER OF A SINGLE LINE OR THE CENTER OF GAP FOR A DOUBLE LINE.
4. EXISTING PAVEMENT MARKINGS IN CONFLICT WITH PROPOSED MARKINGS SHALL BE REMOVED.

LESLIE LANE - PAVEMENT MARKING, SIGNING AND LANDSCAPING PLAN

PLOT DRIVER = ...\\n:\p\dms\0314\...
 PEN TABLE = ...\\p\...
 FILE NAME = ...3015-sht-pmk-landscp02.dgn



USER NAME = mjp	DESIGNED - DTE	REVISED -
	DRAWN - NEM	REVISED -
PLOT SCALE = 40.0000' / in.	CHECKED - DNM	REVISED -
PLOT DATE = 4/14/2016	DATE - 04/15/16	REVISED -

VILLAGE OF VILLA PARK

LESLIE LANE
PAVEMENT MARKING, SIGNING AND LANDSCAPING PLAN

SCALE: 1" = 40' SHEET OF SHEETS STA. TO STA.

F.A. RTE.	SECTION	COUNTY	TOTAL SHEETS	SHEET NO.
		DUPAGE	62	43
CONTRACT NO.				
ILLINOIS FED. AID PROJECT				

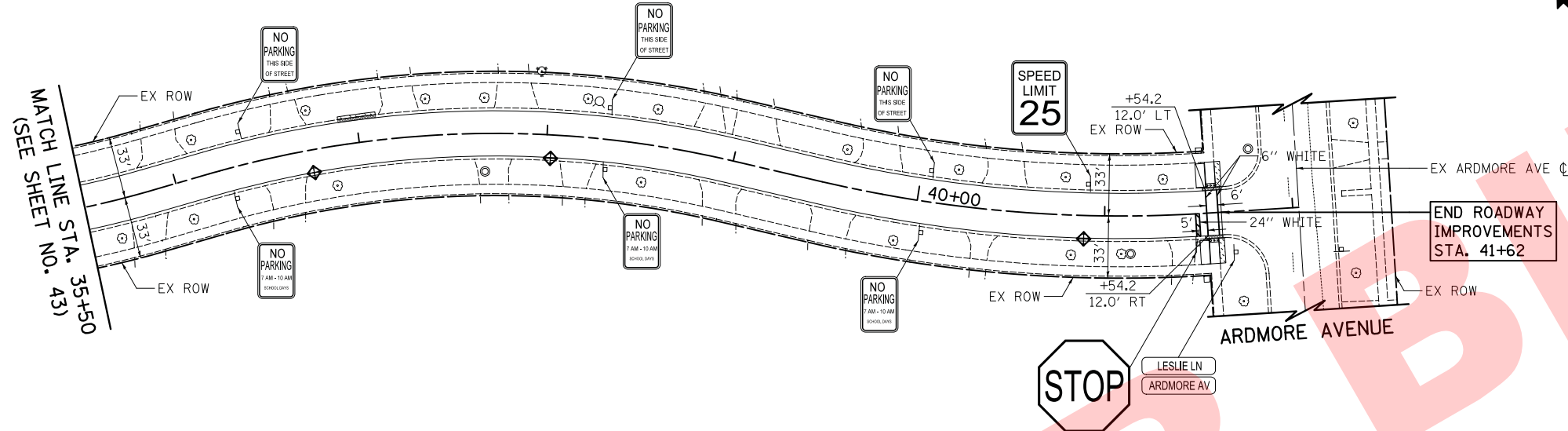

LEGEND

- TOPSOIL FURNISH AND PLACE, 4" SODDING
- INLET FILTERS
- REL RELOCATE SIGN PANEL ASSEMBLY, TYPE A OR B AND NEW TELESCOPING STEEL SIGN SUPPORT
- EX SIGN
- PR SIGN
- PR WHITE LETTERS AND SYMBOLS

NOTES

1. ALL SIGNS ARE EXISTING TO REMAIN UNLESS OTHERWISE NOTED.
2. ALL PERMANENT PAVEMENT MARKINGS SHALL BE THERMOPLASTIC UNLESS OTHERWISE NOTED.
3. DIMENSIONS TO PAVEMENT MARKINGS ARE TO THE CENTER OF A SINGLE LINE OR THE CENTER OF GAP FOR A DOUBLE LINE.
4. EXISTING PAVEMENT MARKINGS IN CONFLICT WITH PROPOSED MARKINGS SHALL BE REMOVED.

LESLIE LANE - PAVEMENT MARKING, SIGNING AND LANDSCAPING PLAN

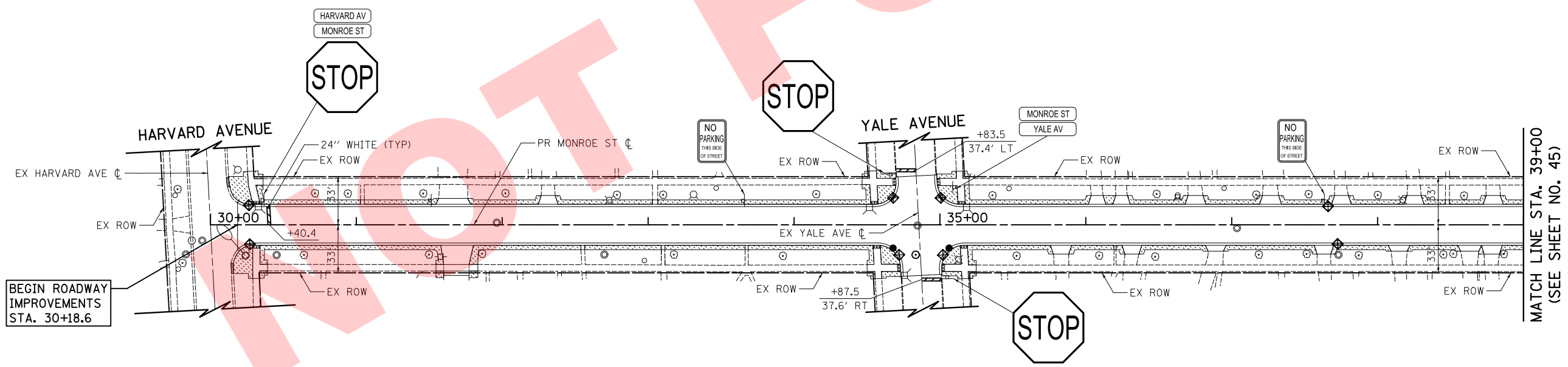

MONROE STREET - PAVEMENT MARKING, SIGNING AND LANDSCAPING PLAN

PLOT DRIVER = ...\\n:\p\dms\0314\mon_pav.pdf.plt
 PEN TABLE = ...\\n:\p\dms\0314\mon_pav.ctb
 FILE NAME = ...\\n:\p\dms\0314\mon_pav.dwg



USER NAME = mjp	DESIGNED - DTE	REVISED -
	DRAWN - NEM	REVISED -
PLOT SCALE = 40.0000' / in.	CHECKED - DNM	REVISED -
PLOT DATE = 4/14/2016	DATE - 04/15/16	REVISED -

VILLAGE OF VILLA PARK

LESLIE LANE AND MONROE STREET
 PAVEMENT MARKING, SIGNING AND LANDSCAPING PLAN

SCALE: 1" = 40' SHEET OF SHEETS STA. TO STA.

F.A. RTE.	SECTION	COUNTY	TOTAL SHEETS	SHEET NO.
			62	44
CONTRACT NO.				
ILLINOIS FED. AID PROJECT				

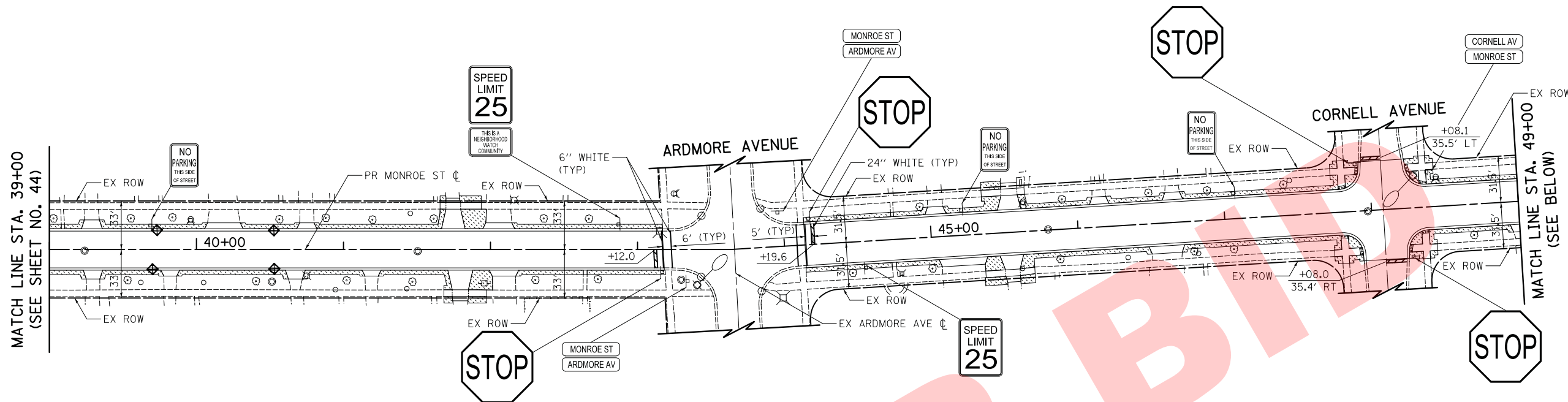

MONROE STREET - PAVEMENT MARKING, SIGNING AND LANDSCAPING PLAN

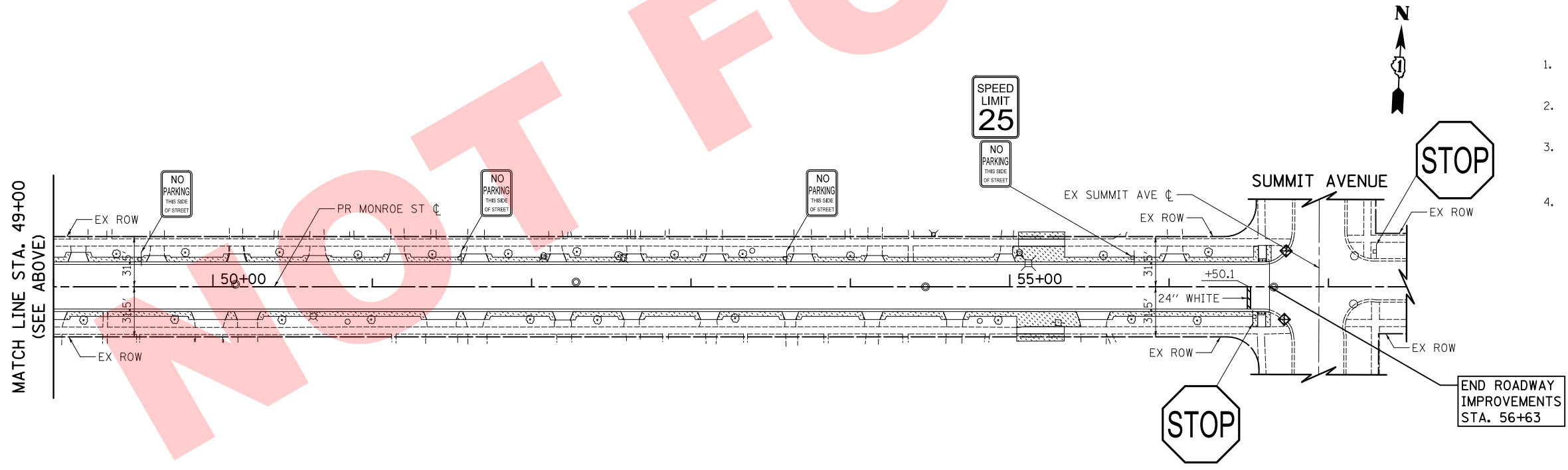

- NOTES**
1. ALL SIGNS ARE EXISTING TO REMAIN UNLESS OTHERWISE NOTED.
 2. ALL PERMANENT PAVEMENT MARKINGS SHALL BE THERMOPLASTIC UNLESS OTHERWISE NOTED.
 3. DIMENSIONS TO PAVEMENT MARKINGS ARE TO THE CENTER OF A SINGLE LINE OR THE CENTER OF GAP FOR A DOUBLE LINE.
 4. EXISTING PAVEMENT MARKINGS IN CONFLICT WITH PROPOSED MARKINGS SHALL BE REMOVED.

- LEGEND**
- TOPSOIL FURNISH AND PLACE, 4" SODDING
 - INLET FILTERS
 - REL RELOCATE SIGN PANEL ASSEMBLY, TYPE A OR B AND NEW TELESCOPING STEEL SIGN SUPPORT
 - EX SIGN
 - PR SIGN
 - PR WHITE LETTERS AND SYMBOLS

MONROE STREET - PAVEMENT MARKING, SIGNING AND LANDSCAPING PLAN

PLOT DRIVER = ...\\n:\p\dms\0314\...
 PEN TABLE = ...\\n:\p\tbl\...
 FILE NAME = ...\\n:\p\tbl\...



USER NAME = mjp	DESIGNED - DTE	REVISED -
	DRAWN - NEM	REVISED -
PLOT SCALE = 40.0000' / 1"	CHECKED - DNM	REVISED -
PLOT DATE = 4/14/2016	DATE - 04/15/16	REVISED -

VILLAGE OF VILLA PARK

MONROE STREET
 PAVEMENT MARKING, SIGNING AND LANDSCAPING PLAN

SCALE: 1" = 40' SHEET OF SHEETS STA. TO STA.

F.A. RTE.	SECTION	COUNTY	TOTAL SHEETS	SHEET NO.
		DUPAGE	62	45
CONTRACT NO.				
ILLINOIS FED. AID PROJECT				

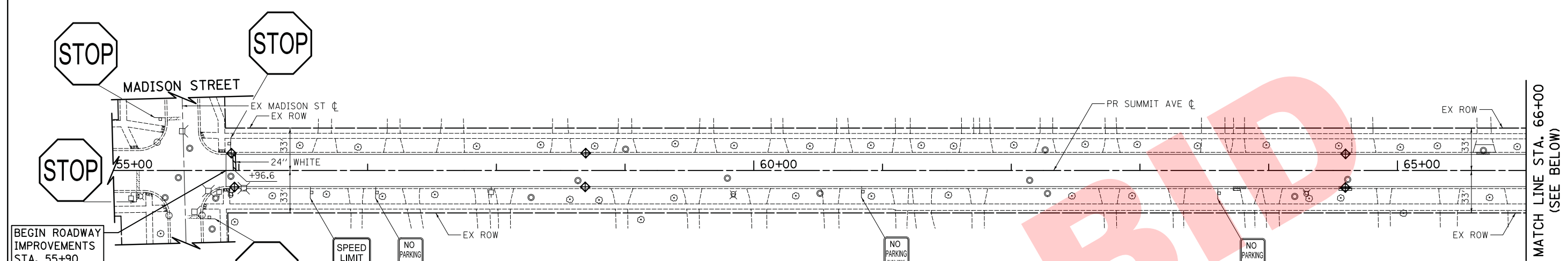

BEGIN ROADWAY IMPROVEMENTS STA. 55+90

MATCH LINE STA. 66+00 (SEE BELOW)

LEGEND

- TOPSOIL FURNISH AND PLACE, 4" SODDING
- INLET FILTERS
- REL RELOCATE SIGN PANEL ASSEMBLY, TYPE A OR B AND NEW TELESCOPING STEEL SIGN SUPPORT
- EX SIGN
- PR SIGN
- PR WHITE LETTERS AND SYMBOLS

SUMMIT AVENUE - PAVEMENT MARKING, SIGNING AND LANDSCAPING PLAN

NOTES

1. ALL SIGNS ARE EXISTING TO REMAIN UNLESS OTHERWISE NOTED.
2. ALL PERMANENT PAVEMENT MARKINGS SHALL BE THERMOPLASTIC UNLESS OTHERWISE NOTED.
3. DIMENSIONS TO PAVEMENT MARKINGS ARE TO THE CENTER OF A SINGLE LINE OR THE CENTER OF GAP FOR A DOUBLE LINE.
4. EXISTING PAVEMENT MARKINGS IN CONFLICT WITH PROPOSED MARKINGS SHALL BE REMOVED.

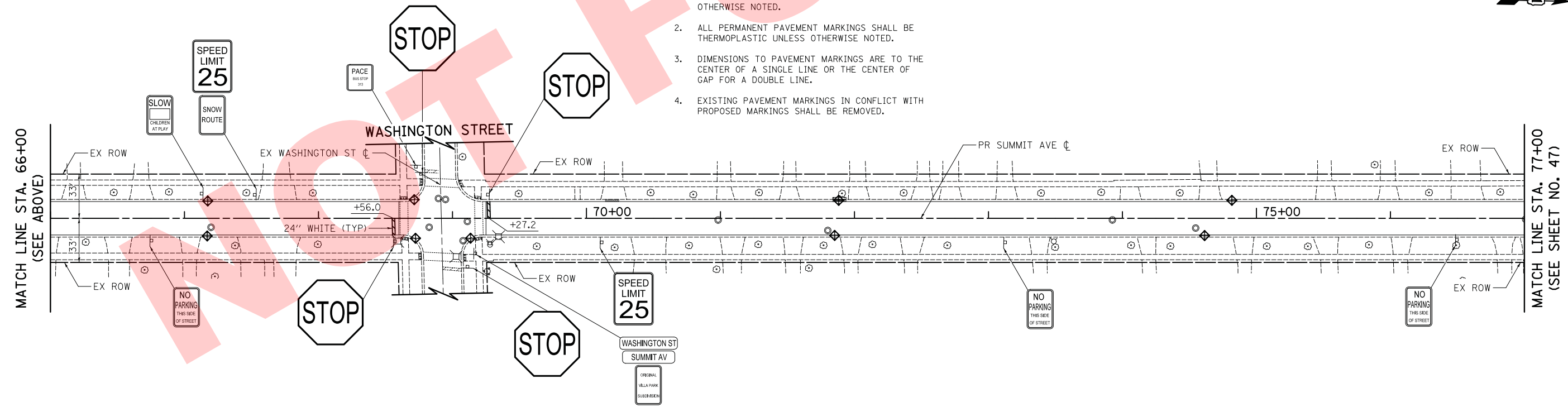

MATCH LINE STA. 66+00 (SEE ABOVE)

MATCH LINE STA. 77+00 (SEE SHEET NO. 47)

SUMMIT AVENUE - PAVEMENT MARKING, SIGNING AND LANDSCAPING PLAN

PLOT DRIVER = ...\\n:\p\dms\0314\ven_paf.plt
PEN TABLE = ...\\n:\p\dms\0314\ven_paf.tbl
FILE NAME = ...\\n:\p\dms\0314\ven_paf.dwg



USER NAME = mjp	DESIGNED - DTE	REVISED -
PLOT SCALE = 40.0000' / in.	DRAWN - NEM	REVISED -
PLOT DATE = 4/14/2016	CHECKED - DNM	REVISED -
	DATE - 04/15/16	REVISED -

VILLAGE OF VILLA PARK

**SUMMIT AVENUE
PAVEMENT MARKING, SIGNING AND LANDSCAPING PLAN**

SCALE: 1" = 40' SHEET OF SHEETS STA. TO STA.

F.A. RTE.	SECTION	COUNTY	TOTAL SHEETS	SHEET NO.
		DUPAGE	62	46
CONTRACT NO.				
ILLINOIS FED. AID PROJECT				

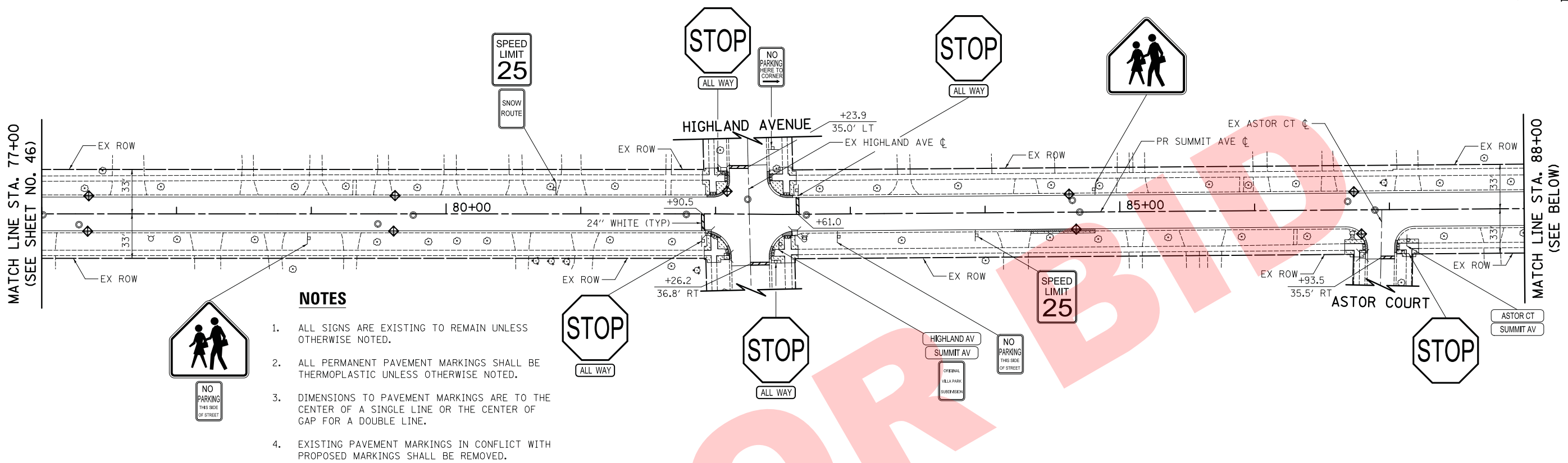
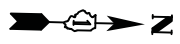

NOTES

1. ALL SIGNS ARE EXISTING TO REMAIN UNLESS OTHERWISE NOTED.
2. ALL PERMANENT PAVEMENT MARKINGS SHALL BE THERMOPLASTIC UNLESS OTHERWISE NOTED.
3. DIMENSIONS TO PAVEMENT MARKINGS ARE TO THE CENTER OF A SINGLE LINE OR THE CENTER OF GAP FOR A DOUBLE LINE.
4. EXISTING PAVEMENT MARKINGS IN CONFLICT WITH PROPOSED MARKINGS SHALL BE REMOVED.

SUMMIT AVENUE - PAVEMENT MARKING, SIGNING AND LANDSCAPING PLAN

LEGEND

- TOPSOIL FURNISH AND PLACE, 4" SODDING
- INLET FILTERS
- REL RELOCATE SIGN PANEL ASSEMBLY, TYPE A OR B AND NEW TELESCOPING STEEL SIGN SUPPORT
- EX SIGN
- PR SIGN
- PR WHITE LETTERS AND SYMBOLS

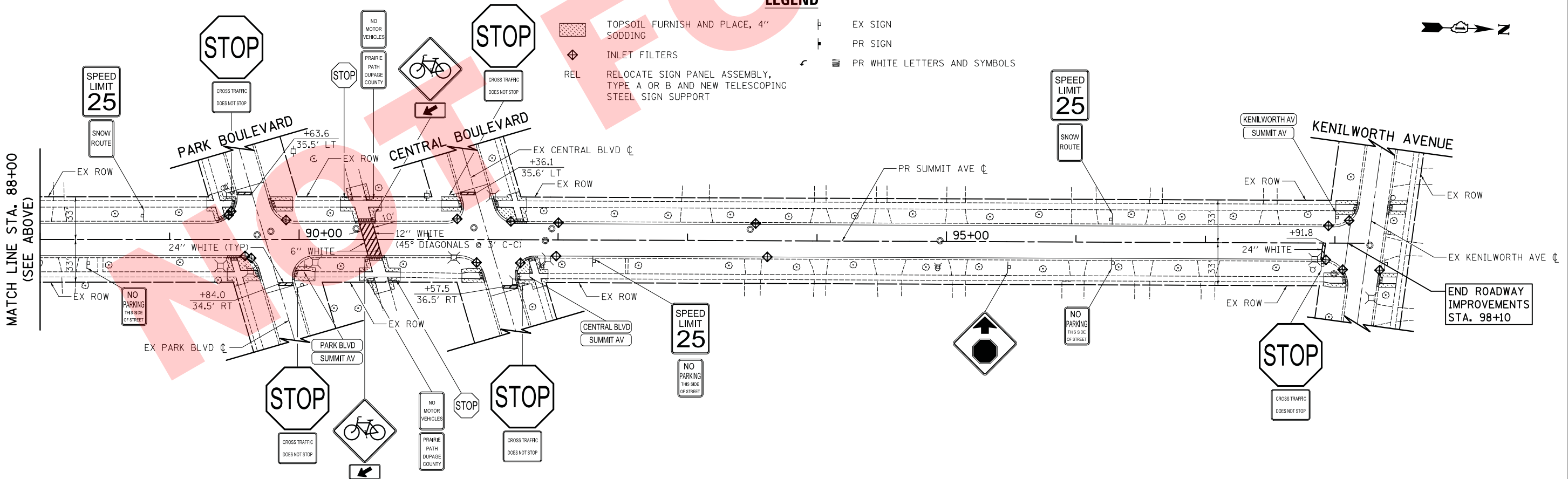

SUMMIT AVENUE - PAVEMENT MARKING, SIGNING AND LANDSCAPING PLAN

PLOT DRIVER = ...\\n:\p\dms\0314\ven_pdf.plt
 PEN TABLE = ...\\n:\p\tbl\cpl\ldot_general.tbl
 FILE NAME = ...3015-shr-pmk-1ndscp06.dgn



USER NAME = mjp	DESIGNED - DTE	REVISED -
	DRAWN - NEM	REVISED -
PLOT SCALE = 40.0000' / in.	CHECKED - DNM	REVISED -
PLOT DATE = 4/14/2016	DATE - 04/15/16	REVISED -

VILLAGE OF VILLA PARK

**SUMMIT AVENUE
 PAVEMENT MARKING, SIGNING AND LANDSCAPING PLAN**

SCALE: 1" = 40' SHEET OF SHEETS STA. TO STA.

F.A. RTE.	SECTION	COUNTY	TOTAL SHEETS	SHEET NO.
		DUPAGE	62	47
CONTRACT NO.				
ILLINOIS FED. AID PROJECT				

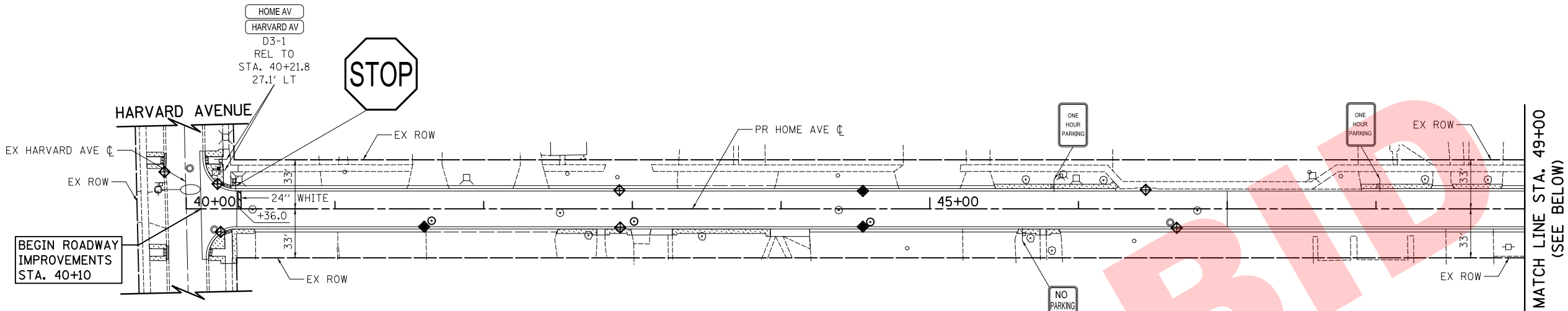

HOME AVENUE - PAVEMENT MARKING, SIGNING AND LANDSCAPING PLAN

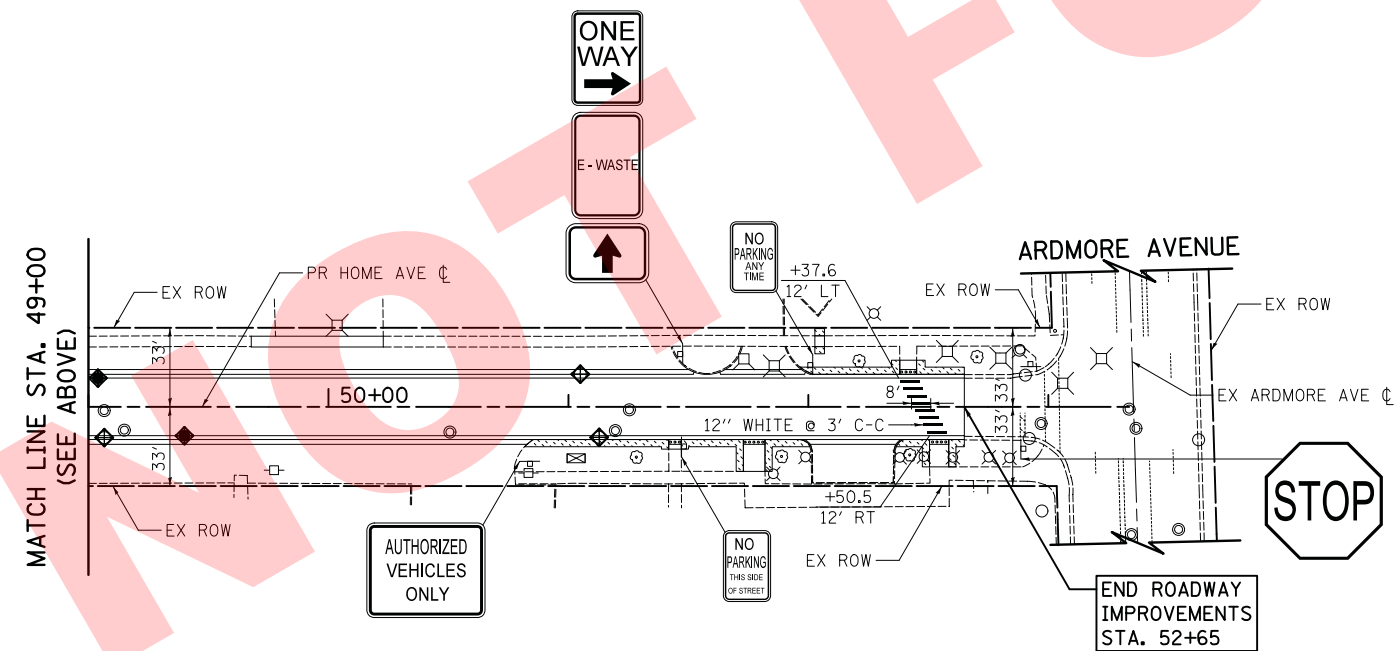

LEGEND

- TOPSOIL FURNISH AND PLACE, 4" SODDING
- INLET FILTERS
- REL RELOCATE SIGN PANEL ASSEMBLY, TYPE A OR B AND NEW TELESCOPING STEEL SIGN SUPPORT
- EX SIGN
- PR SIGN
- PR WHITE LETTERS AND SYMBOLS

NOTES

1. ALL SIGNS ARE EXISTING TO REMAIN UNLESS OTHERWISE NOTED.
2. ALL PERMANENT PAVEMENT MARKINGS SHALL BE THERMOPLASTIC UNLESS OTHERWISE NOTED.
3. DIMENSIONS TO PAVEMENT MARKINGS ARE TO THE CENTER OF A SINGLE LINE OR THE CENTER OF GAP FOR A DOUBLE LINE.
4. EXISTING PAVEMENT MARKINGS IN CONFLICT WITH PROPOSED MARKINGS SHALL BE REMOVED.

HOME AVENUE - PAVEMENT MARKING, SIGNING AND LANDSCAPING PLAN

PLOT DRIVER = ...\\nlp\idm\0314\ven_paf.plt
 PEN TABLE = ...\\pntb\cui\dot_general.tbl
 FILE NAME = ...\\3015-shr-pmk-1ndscp07.dgn



USER NAME = mjp	DESIGNED - DTE	REVISED -
	DRAWN - NEM	REVISED -
PLOT SCALE = 40.0000' / 1"	CHECKED - DNM	REVISED -
PLOT DATE = 4/14/2016	DATE - 04/15/16	REVISED -

VILLAGE OF VILLA PARK

HOME AVENUE
PAVEMENT MARKING, SIGNING AND LANDSCAPING PLAN

SCALE: 1" = 40' SHEET OF SHEETS STA. TO STA.

F.A. RTE.	SECTION	COUNTY	TOTAL SHEETS	SHEET NO.
		DUPAGE	62	48
CONTRACT NO.				
ILLINOIS FED. AID PROJECT				

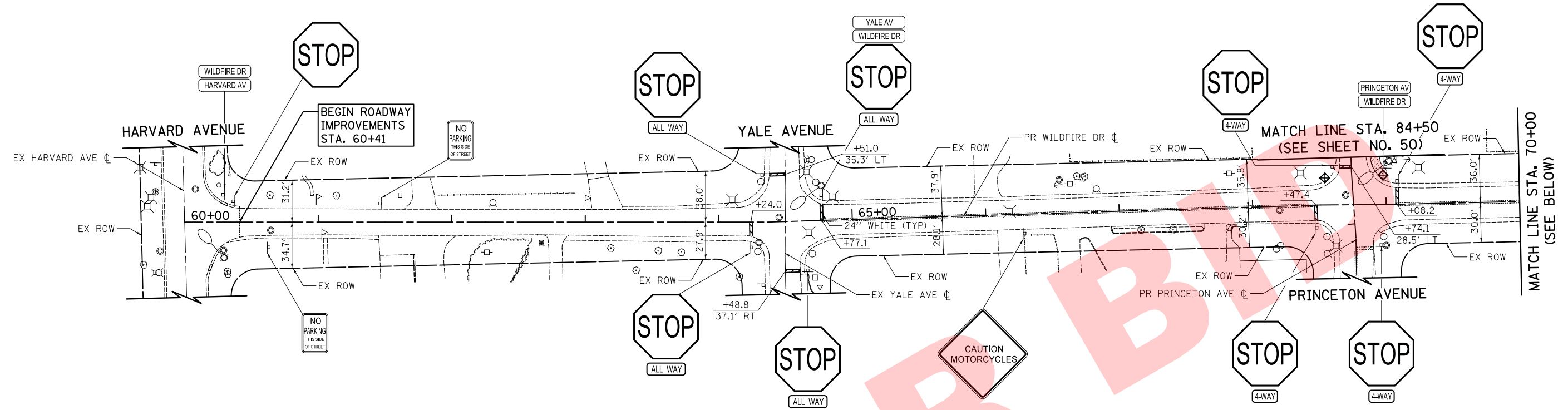

WILDFIRE DRIVE - PAVEMENT MARKING, SIGNING AND LANDSCAPING PLAN

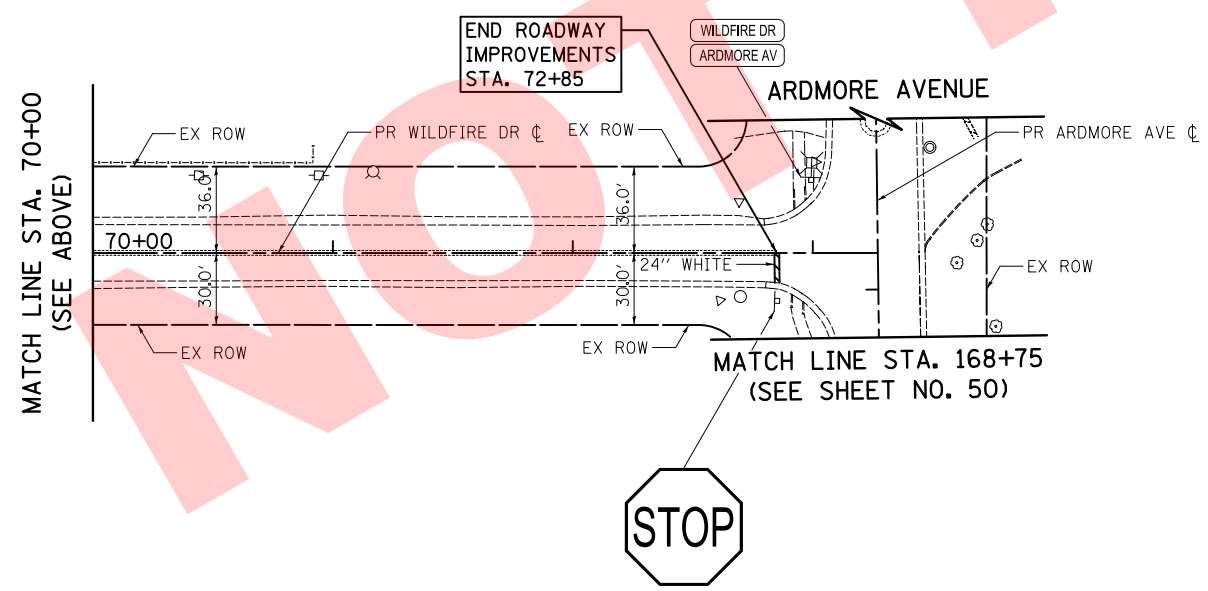

LEGEND

- TOPSOIL FURNISH AND PLACE, 4" SODDING
- INLET FILTERS
- REL RELOCATE SIGN PANEL ASSEMBLY, TYPE A OR B AND NEW TELESCOPING STEEL SIGN SUPPORT
- EX SIGN
- PR SIGN
- PR WHITE LETTERS AND SYMBOLS

NOTES

1. ALL SIGNS ARE EXISTING TO REMAIN UNLESS OTHERWISE NOTED.
2. ALL PERMANENT PAVEMENT MARKINGS SHALL BE THERMOPLASTIC UNLESS OTHERWISE NOTED.
3. DIMENSIONS TO PAVEMENT MARKINGS ARE TO THE CENTER OF A SINGLE LINE OR THE CENTER OF GAP FOR A DOUBLE LINE.
4. EXISTING PAVEMENT MARKINGS IN CONFLICT WITH PROPOSED MARKINGS SHALL BE REMOVED.



WILDFIRE DRIVE - PAVEMENT MARKING, SIGNING AND LANDSCAPING PLAN

PLOT DRIVER = ...\\n:\p\dms\0314\ven_paf.p1t
 PEN TABLE = ...\\pemb\csl\dot_gmrenal.tb1
 FILE NAME = ...3015-shr-pmk-1ndscp08.dgn



USER NAME = mjp	DESIGNED - DTE	REVISED -
	DRAWN - NEM	REVISED -
PLOT SCALE = 40.0000' / in.	CHECKED - DNM	REVISED -
PLOT DATE = 4/14/2016	DATE - 04/15/16	REVISED -

VILLAGE OF VILLA PARK

WILDFIRE DRIVE
PAVEMENT MARKING, SIGNING AND LANDSCAPING PLAN

SCALE: 1" = 40' SHEET OF SHEETS STA. TO STA.

F.A. RTE.	SECTION	COUNTY	TOTAL SHEETS	SHEET NO.
		DUPAGE	62	49
CONTRACT NO.				
ILLINOIS FED. AID PROJECT				

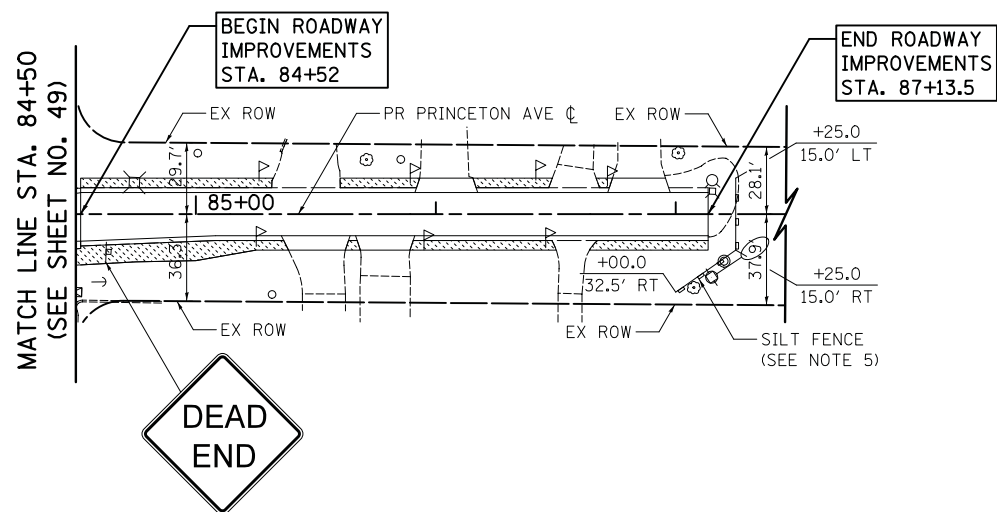

- LEGEND**
- TOPSOIL FURNISH AND PLACE, 4" SODDING
 - INLET FILTERS
 - REL RELOCATE SIGN PANEL ASSEMBLY, TYPE A OR B AND NEW TELESCOPING STEEL SIGN SUPPORT
 - EX SIGN
 - PR SIGN
 - PR WHITE LETTERS AND SYMBOLS

PRINCETON AVENUE - PAVEMENT MARKING, SIGNING AND LANDSCAPING PLAN

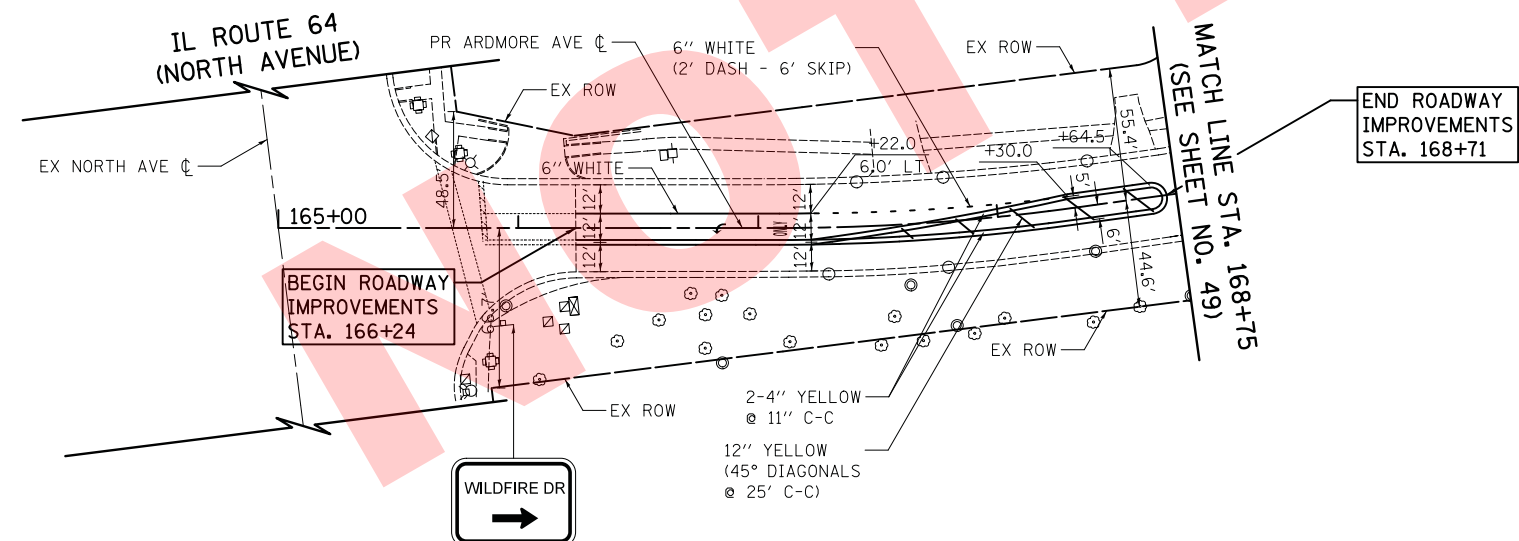

- NOTES**
1. ALL SIGNS ARE EXISTING TO REMAIN UNLESS OTHERWISE NOTED.
 2. ALL PERMANENT PAVEMENT MARKINGS SHALL BE THERMOPLASTIC UNLESS OTHERWISE NOTED.
 3. DIMENSIONS TO PAVEMENT MARKINGS ARE TO THE CENTER OF A SINGLE LINE OR THE CENTER OF GAP FOR A DOUBLE LINE.
 4. EXISTING PAVEMENT MARKINGS IN CONFLICT WITH PROPOSED MARKINGS SHALL BE REMOVED.
 5. SILT FENCE SHALL BE INSTALLED ACCORDING TO THE DETAILS IN THE PLANS AND PAID FOR AS "PERIMETER EROSION BARRIER".

ARDMORE AVENUE - PAVEMENT MARKING, SIGNING AND LANDSCAPING PLAN

PLOT DRIVER = ...\\n:\p\dms\0314\ven_pdf.plt
 PEN TABLE = ...\\pemb\cui\ldot_general.tbl
 FILE NAME = ...3015-shr-pmk-landscp.dgn



USER NAME = mjp	DESIGNED - DTE	REVISED -
	DRAWN - NEM	REVISED -
PLOT SCALE = 40.0000' / 1"	CHECKED - DNM	REVISED -
PLOT DATE = 4/14/2016	DATE - 04/15/16	REVISED -

VILLAGE OF VILLA PARK

PRINCETON AVENUE AND ARDMORE AVENUE
PAVEMENT MARKING, SIGNING AND LANDSCAPING PLAN

SCALE: 1" = 40' SHEET OF SHEETS STA. TO STA.

F.A. RTE.	SECTION	COUNTY	TOTAL SHEETS	SHEET NO.
			62	50
			CONTRACT NO.	
ILLINOIS FED. AID PROJECT				

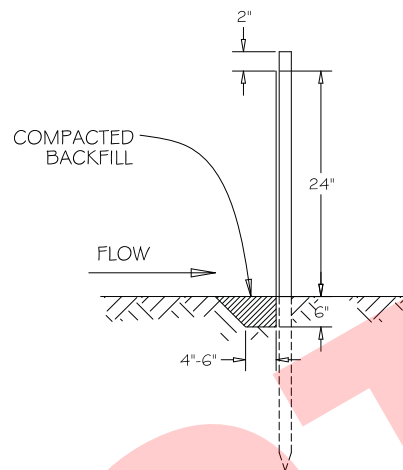
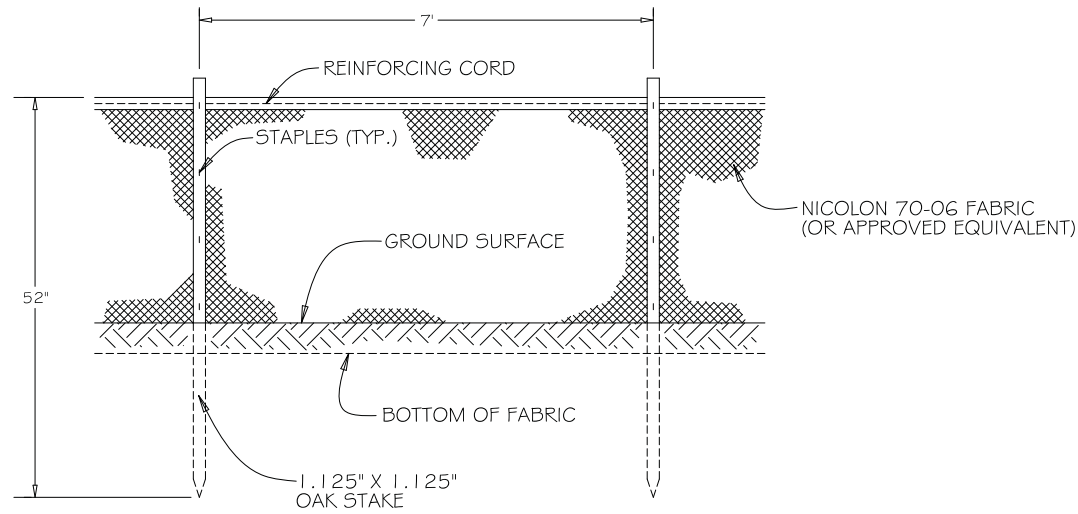

GENERAL NOTES:

1. SILT FENCE SHALL BE MAINTAINED UNTIL THE AREA TRIBUTARY TO THE STRUCTURE HAS STABILIZED GROUND COVER, AS DETERMINED BY THE VILLAGE ENGINEER.

NOT TO SCALE

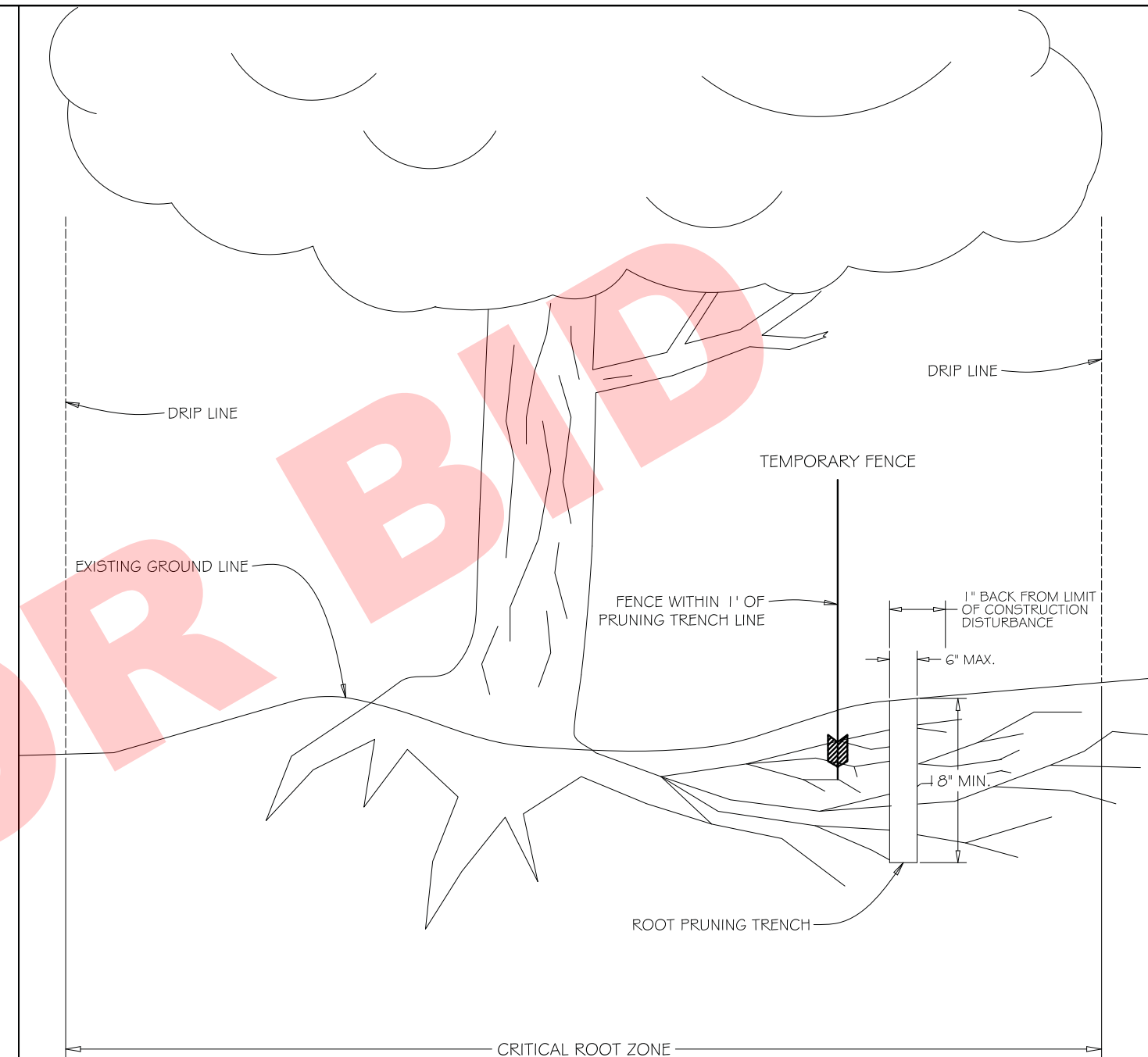

NOT TO SCALE

GENERAL NOTES:

1. EXACT LOCATION OF ROOT PRUNING TO BE AS SPECIFIED BY ENGINEER OR VILLAGE REPRESENTATIVE.
2. BACKFILL ROOT PRUNING TRENCH IMMEDIATELY FOLLOWING COMPLETION OF PRUNING ACTIVITIES.
3. ROOT PRUNING ACTIVITIES AND THE PLACEMENT OF PROTECTIVE FENCING SHALL BE COORDINATED SO THAT BOTH SHALL BE COMPLETED AT EACH LOCATION WITHIN A 48 HOUR PERIOD.
4. UNDER NO CIRCUMSTANCES SHALL CONSTRUCTION PROCEED PRIOR TO THE COMPLETION OF ROOT PRUNING AND THE PLACEMENT OF PROTECTIVE FENCING, NOR SHALL FENCING BE REMOVED WITHOUT PRIOR AUTHORIZATION FROM THE ENGINEER OR VILLAGE REPRESENTATIVE.

REV:	DATE:
REV: RMS	DATE: JUL 2004
DRAWN BY: VV	DATE: JAN 2003

SILT FENCE INSTALLATION

**VILLAGE OF VILLA PARK
ROAD - 11**

TREE AND BUSH ROOT PRUNING

VILLAGE OF VILLA PARK

**2016 STREET IMPROVEMENTS
CONSTRUCTION DETAILS**

F.A. RTE.	SECTION	COUNTY	TOTAL SHEETS	SHEET NO.
			62	51
CONTRACT NO.				

SCALE: N.T.S. SHEET OF SHEETS STA. TO STA.

ILLINOIS FED. AID PROJECT

PLOT DRIVER = ...\\njb\dm00314\...
 PEN TABLE = ...\\njb\dm00314\...
 FILE NAME = ...\\njb\dm00314\...



USER NAME = mjp	DESIGNED - MJP	REVISED -
PLOT SCALE = 1.0000' / 1"	DRAWN - MJP	REVISED -
PLOT DATE = 4/14/2016	CHECKED - DNM	REVISED -
	DATE - 04/15/16	REVISED -

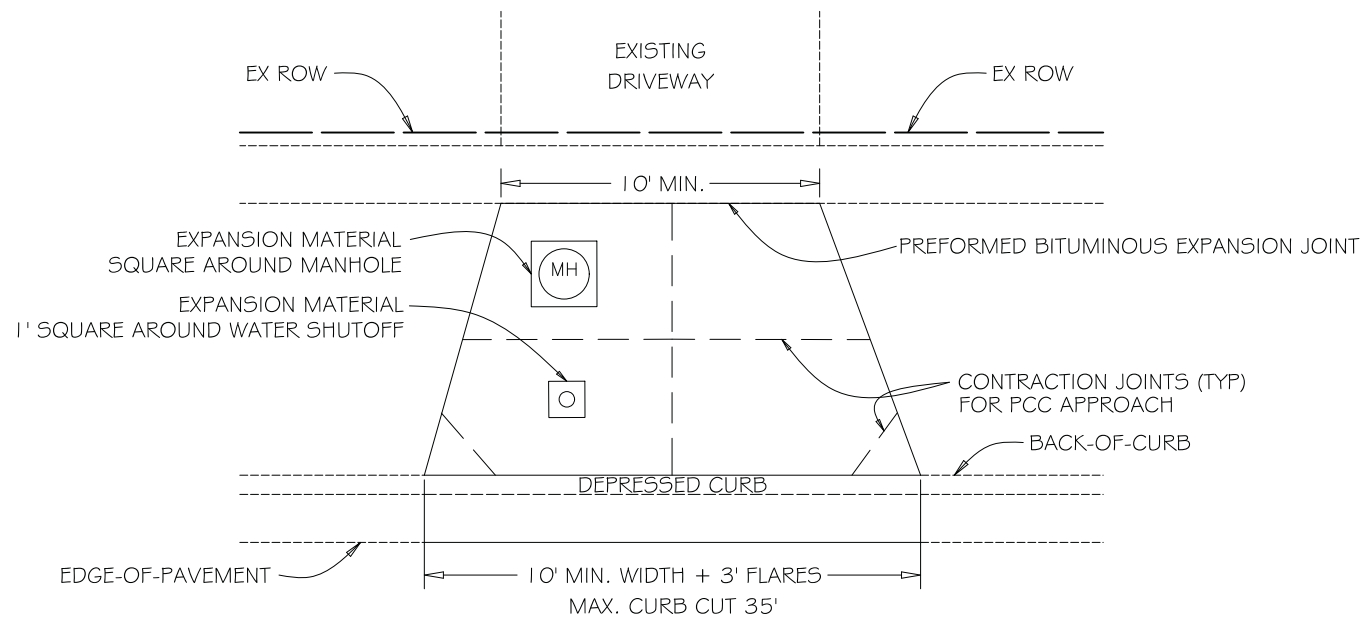

PLAN

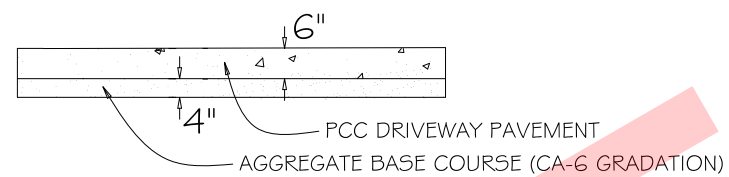

PORTLAND CEMENT CONCRETE DRIVEWAY APRON

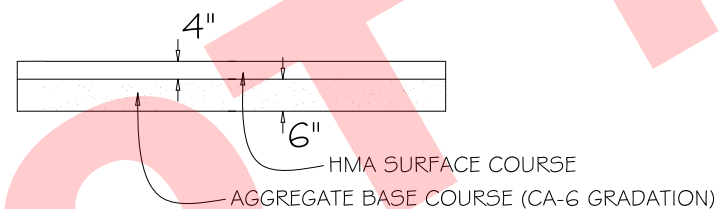

HOT-MIX ASPHALT DRIVEWAY APRON

PROFILE

GENERAL NOTES:

1. DEPRESSING THE CURB THROUGH DRIVEWAY APRON SHALL BE INCLUDED IN THE COST OF THE COMBINATION CONCRETE CURB AND GUTTER BEING CONSTRUCTED.
2. ALL STONE BEDDING SHALL BE MECHANICALLY COMPACTED.
3. SEE "COMBINATION CONCRETE CURB AND GUTTER" DETAIL FOR CURB AND GUTTER CONSTRUCTION.

NOT TO SCALE

TYPICAL DRIVEWAY APPROACH

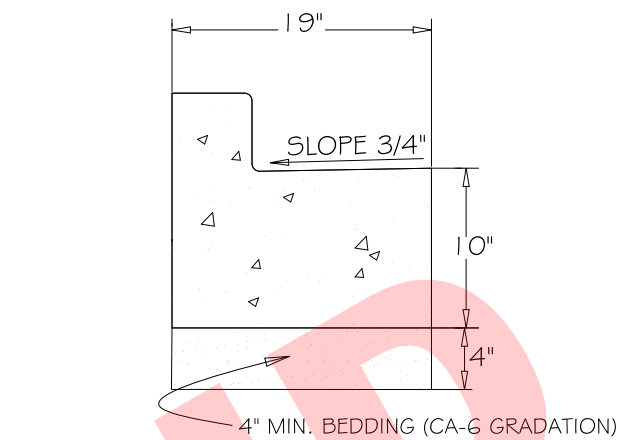

B-6.12

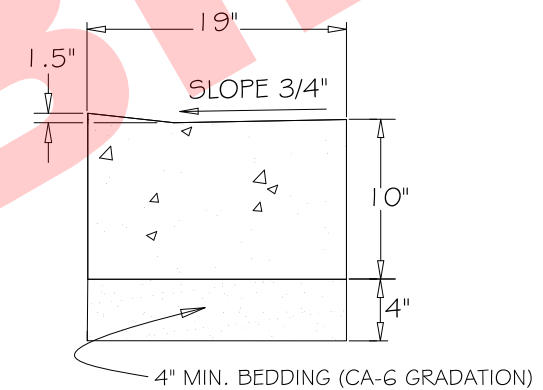

B-6.12 (DEPRESSED)

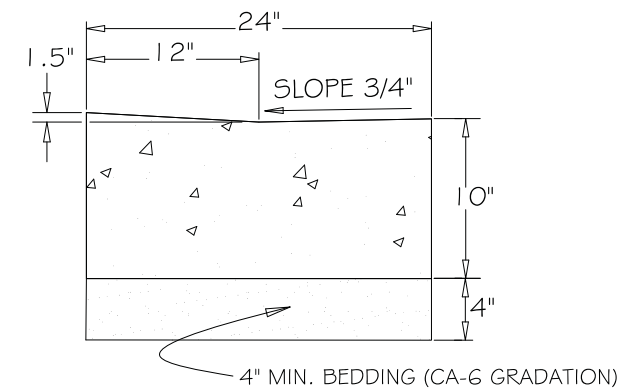

CONCRETE GUTTER (SPECIAL)

INTERSECTION OF HARRISON ST. & ORCHARD HILL CT.

GENERAL NOTES:

1. CONTRACTION JOINTS SHALL BE PLACED BETWEEN EXPANSION JOINTS AT 15' INTERVALS. CONTRACTION JOINTS SHALL INITIALLY BE TOOLED AND THEN SAW CUT WITHIN 24 HOURS OF POURING THE CURB AND GUTTER.
2. EXPANSION JOINTS ARE TO BE PLACED AT 60' INTERVALS. 2 - #6 X 18" REBARS TO BE PLACED AT ALL EXPANSION JOINTS.
3. SEE IDOT HIGHWAY STANDARD 606001 FOR ADDITIONAL CURB AND GUTTER DETAILS.

NOT TO SCALE

COMBINATION CONCRETE CURB AND GUTTER

PLOT DRIVER = ...\\n:\p\dms\0314\con_pdf.plt
 PEN TABLE = ...\\p\tbl\con_idot_general.tbl
 FILE NAME = ...\\3015-st-detailed.dgn



USER NAME = mjp	DESIGNED - MJP	REVISED -
	DRAWN - MJP	REVISED -
PLOT SCALE = 1:8000' / 1"	CHECKED - DNM	REVISED -
PLOT DATE = 4/14/2016	DATE - 04/15/16	REVISED -

VILLAGE OF VILLA PARK

2016 STREET IMPROVEMENTS
 CONSTRUCTION DETAILS

SCALE: N.T.S. SHEET OF SHEETS STA. TO STA.

F.A. RTE.	SECTION	COUNTY	TOTAL SHEETS	SHEET NO.
		DUPAGE	62	52
CONTRACT NO.				
ILLINOIS FED. AID PROJECT				

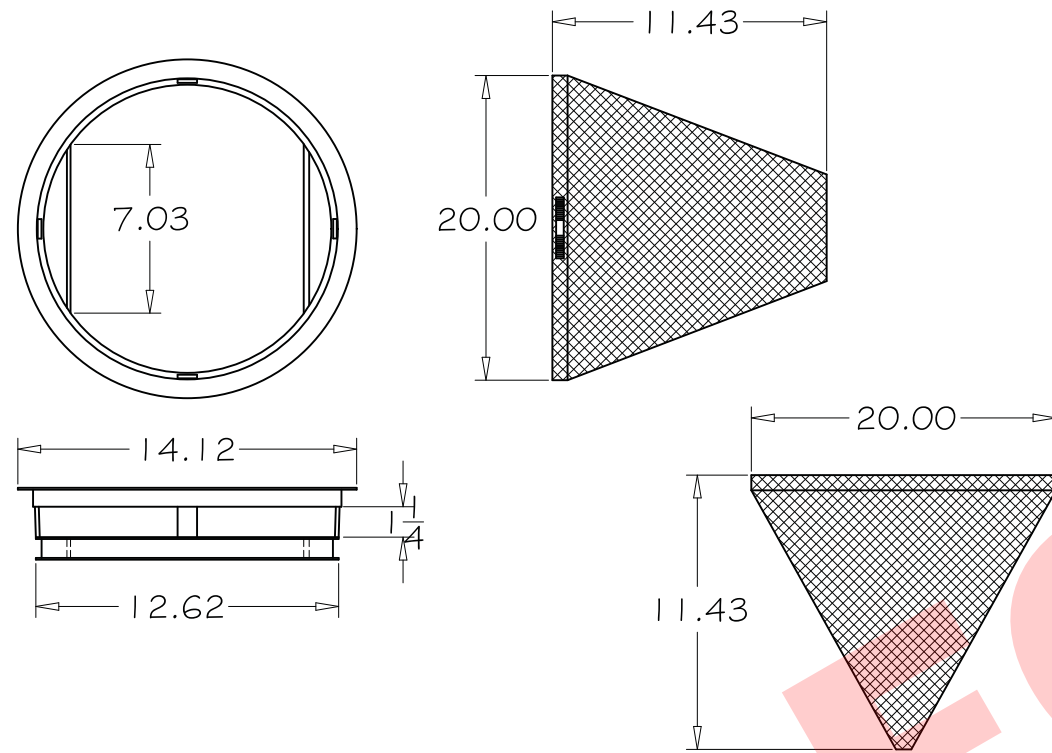

DRAWING BY MARATHON MATERIALS, INC.

GENERAL NOTES:

1. USE DRAINAGE STRUCTURE INLET FILTER MANUFACTURED BY MARATHON MATERIALS, INC. OR APPROVED EQUAL.
2. FRAME: TOP FLANGE FABRICATED FROM 1.25 X 1.25 X 0.125 ANGLE. BASE RIM FABRICATED FROM 1.5 X 0.5 X 0.125 CHANNEL. HANDLES AND SUSPENSION BRACKETS FABRICATED FROM 1.25 X 0.25 FLAT STOCK. ALL DOMESTIC STEEL CONFORMING TO ASTM - A36.
3. SEDIMENT BAG: BAG FABRICATED FROM 4 OZ./SQ. YD. NON-WOVEN POLYPROPYLENE GEOTEXTILE REINFORCED WITH POLYESTER MESH. BAG SECURED TO BASE RIM WITH A STAINLESS STEEL STRAP AND LOCK.

NOT TO SCALE

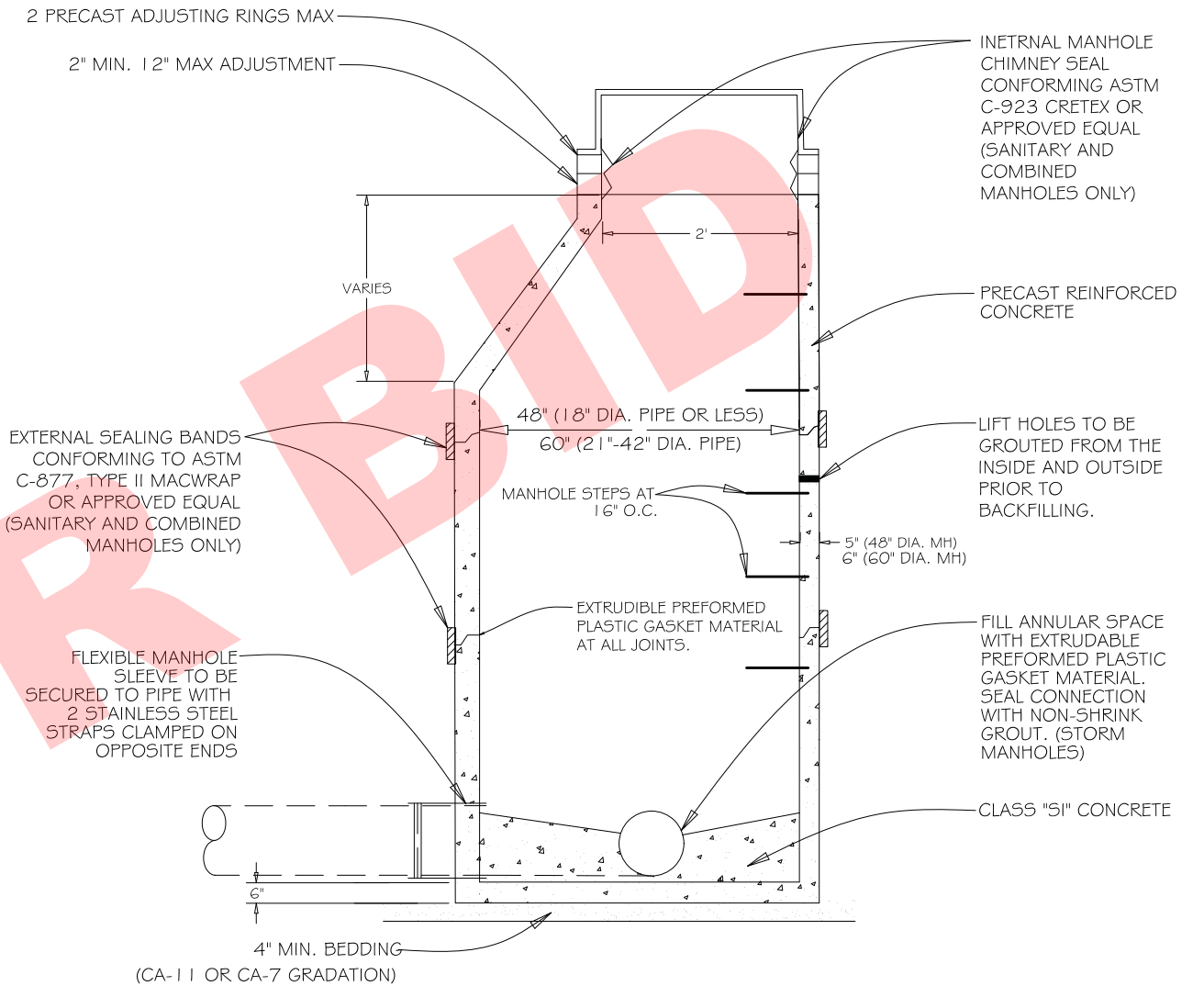

GENERAL NOTES:

1. FRAME AND LID (SANITARY): NEENAH R-1713 (SELF SEALING LID)
2. FRAME AND LID (STORM): NEENAH R-1713
3. ALL LIFT HOLES ARE TO BE GROUTED FROM INSIDE AND OUTSIDE BEFORE BACKFILLING.
4. ONLY PLASTIC POLYMER STEPS SHALL BE USED.

NOT TO SCALE

REV:	DATE:
REV: RMS	DATE: JUL 2004
DRAWN BY: VV	DATE: JAN 2003

DRAINAGE STRUCTURE PROTECTION

VILLAGE OF VILLA PARK
STORM - 17

STANDARD MANHOLE

PLOT DRIVER = ...\\n:\p\dms\0314\ven\pdf\p1.t
PEN TABLE = ...\\n:\p\dms\0314\ven\pdf\p1.t
FILE NAME = ...\\n:\p\dms\0314\ven\pdf\p1.t



USER NAME = mjp
PLOT SCALE = 1:8000' / 1"
PLOT DATE = 4/14/2016

DESIGNED - MJP	REVISED -
DRAWN - MJP	REVISED -
CHECKED - DNM	REVISED -
DATE - 04/15/16	REVISED -

VILLAGE OF VILLA PARK

2016 STREET IMPROVEMENTS
CONSTRUCTION DETAILS

SCALE: N.T.S. SHEET OF SHEETS STA. TO STA.

F.A. RTE.	SECTION	COUNTY	TOTAL SHEETS	SHEET NO.
			62	53
CONTRACT NO.				
ILLINOIS FED. AID PROJECT				

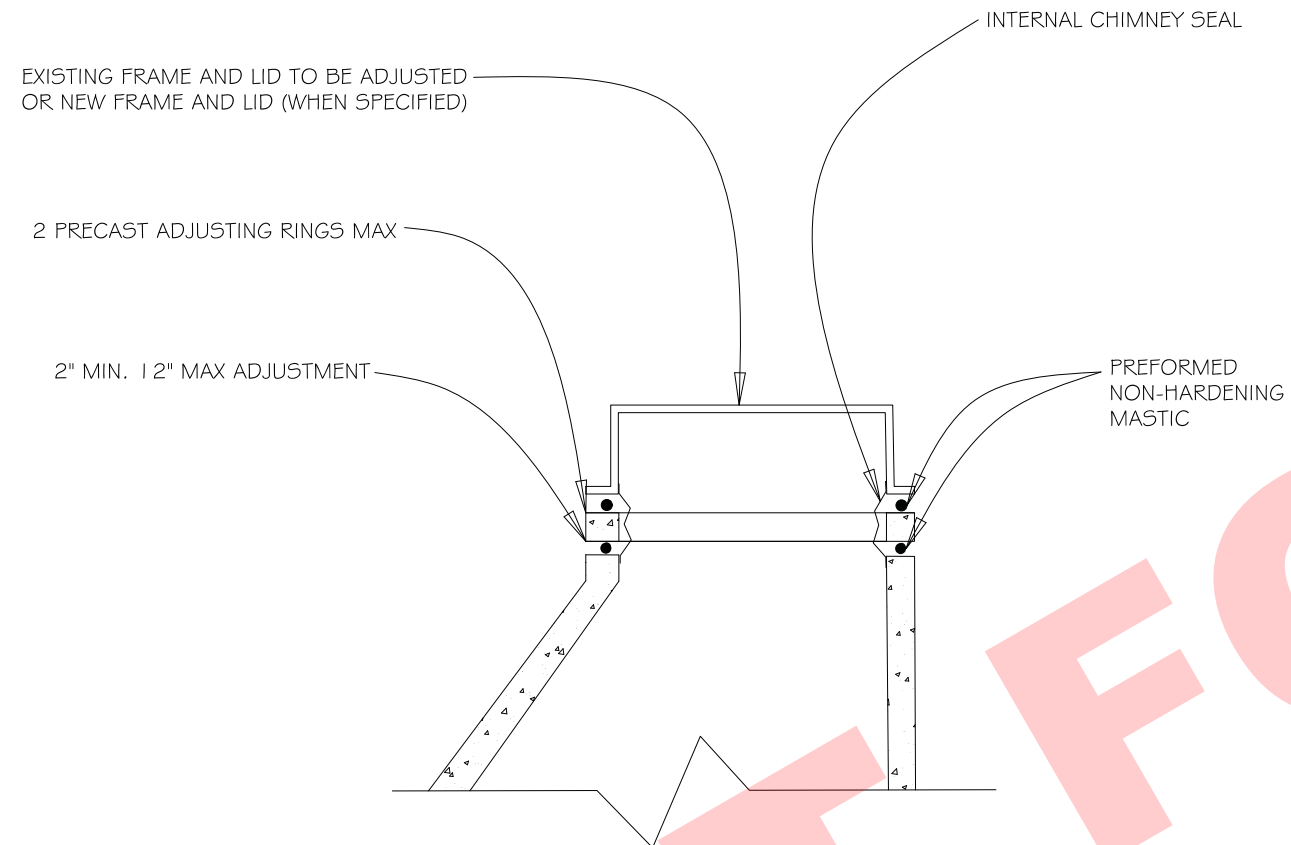

GENERAL NOTES:

1. INTERNAL MANHOLE CHIMNEY SEAL CONFORMING TO ASTM C-923 CRETEX OR APPROVED EQUAL (SANITARY AND COMBINED MANHOLES ONLY)
2. FRAME AND LID (SANITARY):
NEENAH R-1713 (SELF SEALING LID)
3. FRAME AND LID (STORM):
NEENAH R-1713

NOT TO SCALE

TYPICAL ADJUSTMENT

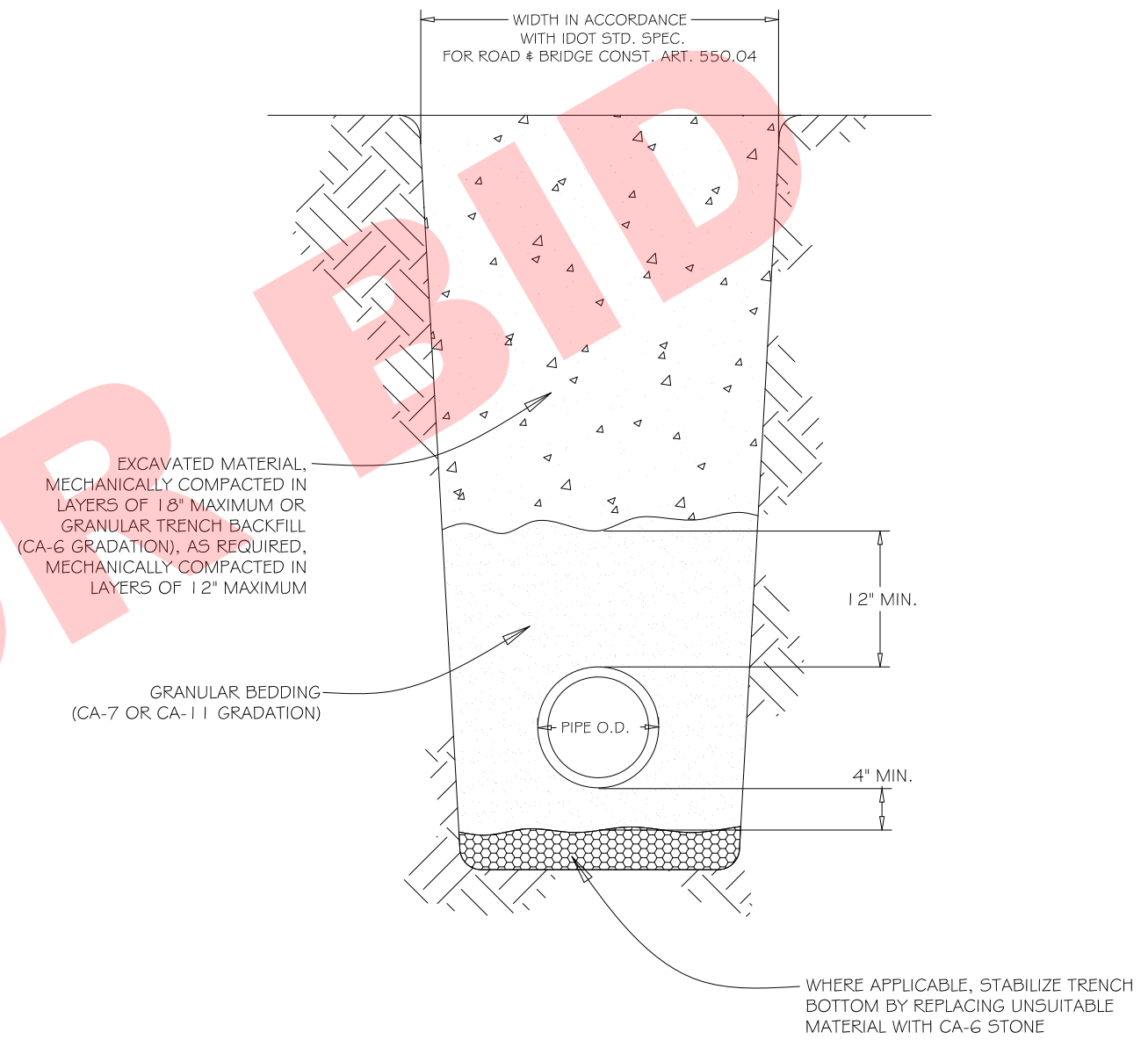

GENERAL NOTES:

1. GRANULAR TRENCH BACKFILL SHALL BE MECHANICALLY COMPACTED IN LAYERS OF 1.2" MAXIMUM, LOOSE MEASURE, TO 95% OF STANDARD MAXIMUM DENSITY (ASTM D 698)
2. EXCAVATED MATERIAL USED FOR BACKFILL SHALL BE MECHANICALLY COMPACTED IN LAYERS OF 1.8" MAXIMUM, LOOSE MEASURE, TO 90% OF STANDARD MAXIMUM DENSITY (ASTM D 698)
3. TRENCH BACKFILL SHALL BE USED IN LOCATIONS SPECIFIED BY SECTION 208 OF THE STANDARD SPECIFICATIONS.

NOT TO SCALE

PIPE INSTALLATION

PLOT DRIVER = ...\\n:\p\dms\0314\con_pdf.plt
 PEN TABLE = ...\\n:\p\tbl\con_idot_general.tbl
 FILE NAME = ...\\3015-shr-detail\164.dgn



USER NAME = mjp	DESIGNED - MJP	REVISED -
	DRAWN - MJP	REVISED -
PLOT SCALE = 1.0000' / 1in.	CHECKED - DNM	REVISED -
PLOT DATE = 4/14/2016	DATE - 04/15/16	REVISED -

VILLAGE OF VILLA PARK

**2016 STREET IMPROVEMENTS
CONSTRUCTION DETAILS**

SCALE: N.T.S. SHEET OF SHEETS STA. TO STA.

F.A. RTE.	SECTION	COUNTY	TOTAL SHEETS	SHEET NO.
			62	54
CONTRACT NO.				
ILLINOIS FED. AID PROJECT				

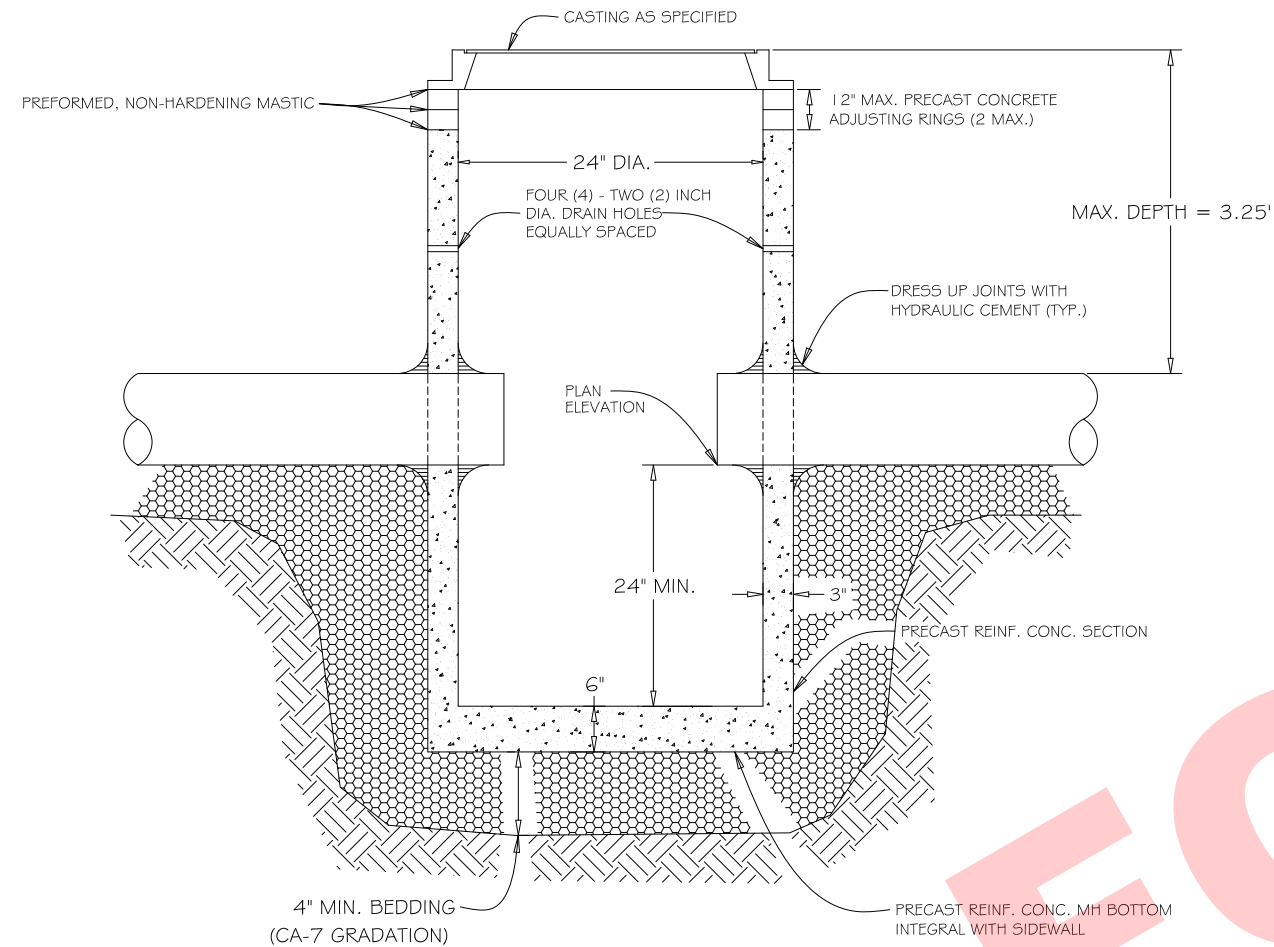

GENERAL NOTES:

1. PROVIDE PRECAST REINFORCED CONCRETE BARREL AND RISER SECTION. CONCRETE BLOCK CONSTRUCTION IS NOT PERMITTED.
2. PROVIDE GRANULAR BACKFILL AROUND CATCH BASIN TO SUBGRADE ELEVATION IN PAVED AREAS. MATERIAL SHALL MEET THE REQUIREMENTS OF IDOT "STANDARD SPECIFICATIONS FOR ROAD AND BRIDGE CONSTRUCTION" FOR COARSE AGGREGATE (CA-6 GRADATION.)
3. WHEN THE FRAME DOES NOT MEET PROPOSED ELEVATION, A MAXIMUM OF TWO PRECAST CONCRETE RINGS MAY BE USED TO A MAXIMUM HEIGHT OF 12 INCHES. THE RING(S) AND FRAME SHALL BE SET IN A BED OF PREFORMED NON-HARDENING MASTIC (RUB-R-NEK, EZ STICK OR APPROVED EQUAL).
4. PRECAST ADJUSTING RINGS SHALL BE REINFORCED WITH NO. 3 GAUGE WIRE OR EQUIVALENT AND SHALL HAVE A MINIMUM THICKNESS OF TWO INCHES.
5. MORTAR SHALL NOT BE USED TO DRESS UP ADJUSTING RINGS AND/OR FRAME.
6. DRESS UP INTERIOR JOINTS WITH HYDRAULIC CEMENT.
7. IN PAVED AREAS, DRAIN HOLES/WEEP HOLES SHALL BE COVERED WITH FILTER FABRIC. FILTER FABRIC SHALL BE SECURED TO THE OUTSIDE OF STRUCTURE PRIOR TO BACKFILL.
8. IN GRASSED AREAS, DRAIN HOLES/WEEP HOLES SHALL BE PLUGGED WITH HYDRAULIC CEMENT.

NOT TO SCALE

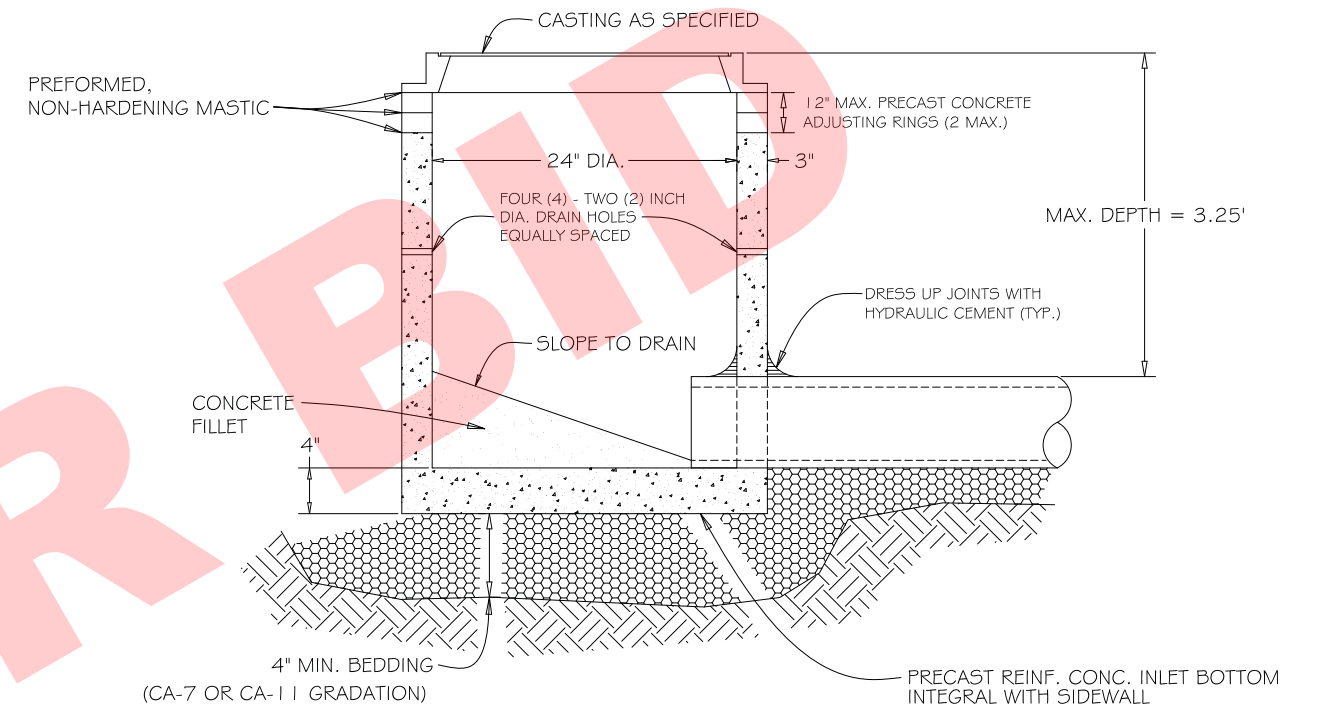

GENERAL NOTES:

1. PROVIDE PRECAST REINFORCED CONCRETE BARREL AND RISER SECTION. CONCRETE BLOCK CONSTRUCTION IS NOT PERMITTED.
2. PROVIDE GRANULAR BACKFILL AROUND INLET TO SUBGRADE ELEVATION IN PAVED AREAS. MATERIAL SHALL MEET THE REQUIREMENTS OF IDOT "STANDARD SPECIFICATIONS FOR ROAD AND BRIDGE CONSTRUCTION" FOR COARSE AGGREGATE (CA-6 GRADATION.)
3. WHEN THE FRAME DOES NOT MEET PROPOSED ELEVATION, A MAXIMUM OF TWO PRECAST CONCRETE RINGS MAY BE USED TO A MAXIMUM HEIGHT OF 12 INCHES. THE RING(S) AND FRAME SHALL BE SET IN A BED OF PREFORMED NON-HARDENING MASTIC (RUB-R-NEK, EZ STICK OR APPROVED EQUAL).
4. PRECAST ADJUSTING RINGS SHALL BE REINFORCED WITH NO. 3 GAUGE WIRE OR EQUIVALENT AND SHALL HAVE A MINIMUM THICKNESS OF TWO INCHES.
5. MORTAR SHALL NOT BE USED TO DRESS UP ADJUSTING RINGS AND/OR FRAME.
6. DRESS UP INTERIOR JOINTS WITH HYDRAULIC CEMENT.
7. IN PAVED AREAS, DRAIN HOLES/WEEP HOLES SHALL BE COVERED WITH FILTER FABRIC. FILTER FABRIC SHALL BE SECURED TO THE OUTSIDE OF STRUCTURE PRIOR TO BACKFILL.
8. IN GRASSED AREAS, DRAIN HOLES/WEEP HOLES SHALL BE PLUGGED WITH HYDRAULIC CEMENT.

NOT TO SCALE

REV:	DATE:
REV: RMS	DATE: JUL 2004
DRAWN BY: VV	DATE: JAN 2003

CATCH BASIN TYPE "C"

VILLAGE OF VILLA PARK
STORM - 01

INLET TYPE "A"

PLOT DRIVER = ...\\n:\p\dms\0314\ven.pdf.plt
 PEN TABLE = ...\\n:\p\dms\pen.tbl
 FILE NAME = ...\\n:\p\dms\0314\ven.pdf.plt



USER NAME = mjp	DESIGNED - MJP	REVISED -
PLOT SCALE = 1:8000 / 1/8"	DRAWN - MJP	REVISED -
PLOT DATE = 4/14/2016	CHECKED - DNM	REVISED -
	DATE - 04/15/16	REVISED -

VILLAGE OF VILLA PARK

2016 STREET IMPROVEMENTS
CONSTRUCTION DETAILS

SCALE: N.T.S. SHEET OF SHEETS STA. TO STA.

F.A. RTE.	SECTION	COUNTY	TOTAL SHEETS	SHEET NO.
			62	55
CONTRACT NO.				
ILLINOIS FED. AID PROJECT				

NOT FOR

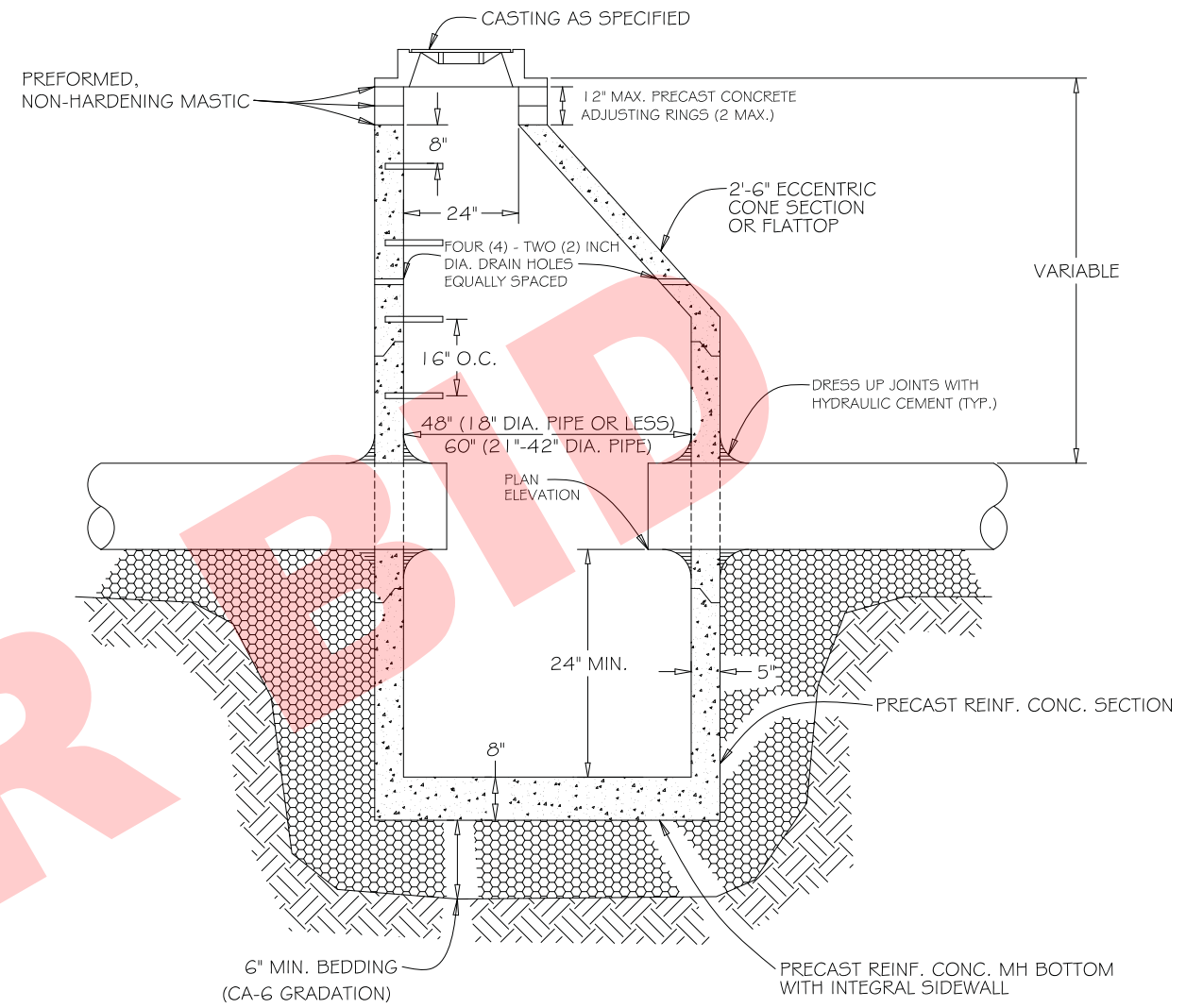

GENERAL NOTES:

1. PROVIDE PRECAST REINFORCED CONCRETE BARREL AND RISER SECTION. CONCRETE BLOCK CONSTRUCTION IS NOT PERMITTED.
2. PROVIDE GRANULAR BACKFILL AROUND CATCH BASIN TO SUBGRADE ELEVATION IN PAVED AREAS. MATERIAL SHALL MEET THE REQUIREMENTS OF IDOT "STANDARD SPECIFICATIONS FOR ROAD AND BRIDGE CONSTRUCTION" FOR COARSE AGGREGATE (CA-6 GRADATION.)
3. APPLY A CONTINUOUS LAYER OF NON-HARDENING PREFORMED BITUMINOUS MASTIC MATERIAL (RUB-R-NEK OR EZ STICK) TO EACH JOINT TO PREVENT INFLOW.
4. WHEN THE FRAME DOES NOT MEET PROPOSED ELEVATION, A MAXIMUM OF TWO PRECAST CONCRETE RINGS MAY BE USED TO A MAXIMUM HEIGHT OF 12 INCHES. THE RING(S) AND FRAME SHALL BE SET IN A BED OF PREFORMED NON-HARDENING MASTIC (RUB-R-NEK, EZ STICK OR APPROVED EQUAL).
5. PRECAST ADJUSTING RINGS SHALL BE REINFORCED WITH NO. 3 GAUGE WIRE OR EQUIVALENT AND SHALL HAVE A MINIMUM THICKNESS OF TWO INCHES.
6. MORTAR SHALL NOT BE USED TO DRESS UP ADJUSTING RINGS AND/OR FRAME. DRESS UP INTERIOR JOINTS WITH HYDRAULIC CEMENT.
7. ONLY PLASTIC POLYMER STEPS SHALL BE USED.
8. WHEN CATCH BASIN DEPTH IS OVER 12 FEET, THE THICKNESS OF THE PRECAST REINFORCED CONCRETE BASE SHALL BE A MINIMUM OF 10 INCHES. WHEN CATCH BASIN DEPTH IS LESS THAN 12 FEET, THE THICKNESS SHALL BE A MINIMUM OF 8 INCHES.
9. DRESS UP INTERIOR JOINTS OF PRECAST CATCHBASIN AND OPENINGS AROUND THE PIPES WITH HYDRAULIC CEMENT.
10. IN PAVED AREAS, DRAIN HOLES/WEEP HOLES SHALL BE COVERED WITH FILTER FABRIC. FILTER FABRIC SHALL BE SECURED TO THE OUTSIDE OF STRUCTURE PRIOR TO BACKFILL.
11. IN GRASSED AREAS, DRAIN HOLES/WEEP HOLES SHALL BE PLUGGED WITH HYDRAULIC CEMENT.

NOT TO SCALE

CATCH BASIN TYPE "A"

PLOT DRIVER = ...\\n:\p\dms\00314\con_pdf\p1.t
PEN TABLE = ...\\n:\p\dms\00314\con_pdf\pen.tbl
FILE NAME = ...\\n:\p\dms\00314\con_pdf\p1.t



USER NAME = mjp	DESIGNED - MJP	REVISED -
	DRAWN - MJP	REVISED -
PLOT SCALE = 1/8" = 1' / 1"	CHECKED - DNM	REVISED -
PLOT DATE = 4/14/2016	DATE - 04/15/16	REVISED -

VILLAGE OF VILLA PARK

**2016 STREET IMPROVEMENTS
CONSTRUCTION DETAILS**

SCALE: N.T.S. SHEET OF SHEETS STA. TO STA.

F.A. RTE.	SECTION	COUNTY	TOTAL SHEETS	SHEET NO.
		DUPAGE	62	56
CONTRACT NO.				
ILLINOIS FED. AID PROJECT				

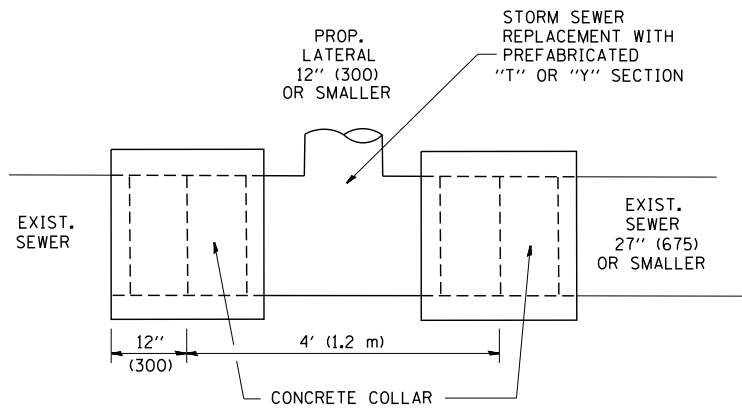

DETAIL "A"

LATERAL CONNECTION TO EXISTING SEWER OF 27" (675) OR SMALLER

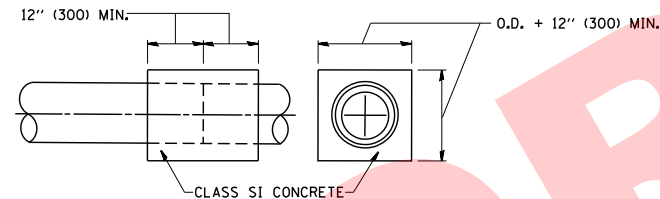
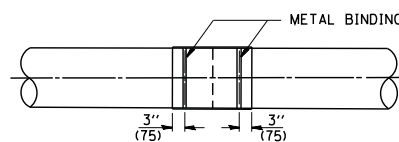
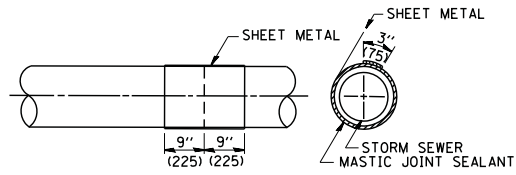
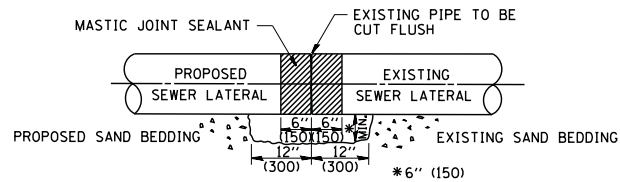

DETAIL "B"

CLASS SI CONCRETE COLLAR

CONSTRUCTION SEQUENCE

- CUT THE EXISTING END OF THE PIPE SO AS TO PRESENT A FLUSH BUTT JOINT. BRUSH AND CLEAN ALL PIPES.
- APPLY THE MASTIC JOINT SEALANT TO THE FIRST 6" (150) OF EACH PIPE.
- BUTT THE PIPES TOGETHER LEAVING A MINIMUM OF 12" x 6" (300 x 150) DEEP EXCAVATION UNDER AND AROUND EACH PIPE END.
- CUT A PIECE OF SHEET METAL GAGE NO. 19 1.1 (0.0418) 18" (450) WIDE BY THE OUTSIDE CIRCUMFERENCE OF THE PIPE PLUS 3" (75) LONG.
- WRAP THE SHEET METAL AROUND THE PIPES, 9" (225) ON EACH SIDE OF THE JOINT, STARTING AT THE TOP OF THE PIPE.
- LAP THE SHEET METAL AT LEAST 3" (75) AT THE TOP OF THE PIPE AND PLACE THE MASTIC JOINT SEALANT BETWEEN THE LAP.
- PLACE TWO METAL BANDS AROUND THE SHEET METAL AND TIGHTEN.
- WIPE OFF ANY EXCESS MASTIC JOINT SEALANT THAT OOOZES OUT FROM BETWEEN THE SHEET METAL AND THE PIPES.
- PLACE CLASS SI CONCRETE AROUND THE JOINT.

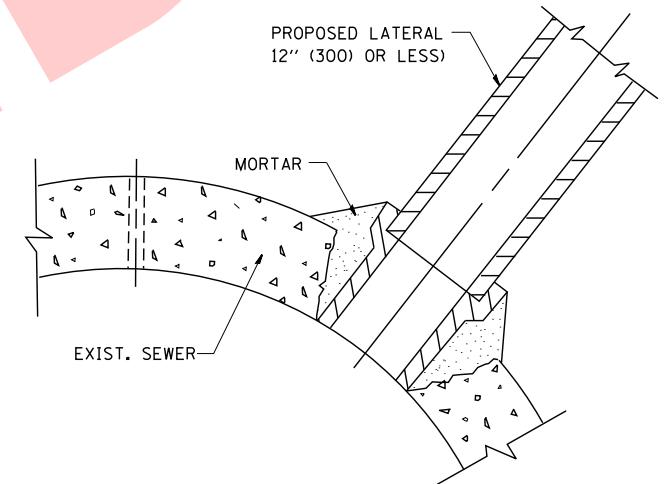

DETAIL "C"

PROPOSED LATERAL CONNECTION TO EXISTING SEWER OF 30" (750) OR LARGER

NOTES

MATERIAL

MATERIAL USED FOR THE TEE OR WYE SECTION SHALL BE COMPATIBLE WITH THE EXISTING STORM SEWER OR THE PROPOSED STORM SEWER.

CONSTRUCTION METHODS

- THIS WORK SHALL BE CONSTRUCTED IN CONFORMANCE WITH THE APPLICABLE PORTIONS OF SECTION 550 OF THE STANDARD SPECIFICATIONS.
- CONNECTION TO AN EXISTING STORM SEWER SHALL BE BY EITHER OF THE FOLLOWING METHODS:
 - PROPOSED STORM SEWER CONNECTION TO EXISTING SEWER OF 27" (675) OR SMALLER SEE DETAIL "A" AND "B".
 - PROPOSED STORM SEWER CONNECTION TO EXISTING SEWER OF 30" (750) OR LARGER SEE DETAIL "C".

IF THE EXISTING SEWER PIPE IS CRACKED, BROKEN OR OTHERWISE DAMAGED BY THE CONTRACTOR IN MAKING THE CIRCULAR OPENING, THE CONTRACTOR SHALL REPLACE THAT SECTION OF PIPE WITH PIPE EQUAL AND SIMILAR IN ALL RESPECTS TO THE PIPE IN THE EXISTING SEWER, IN A CAREFUL WORKMANLIKE MANNER, WITHOUT EXTRA COMPENSATION.

GENERAL

CARE MUST BE TAKEN TO PREVENT DEBRIS FROM ENTERING THE SEWER. ALL DEBRIS WHICH ENTERS THE SEWER MUST BE REMOVED. THE SEWER MUST BE LEFT CLEAN AND UNOBSTRUCTED UPON COMPLETION OF THE CONTRACT.

CARE MUST BE TAKEN TO PREVENT ANY PART OF THE NEW PIPE CONNECTION FROM PROJECTING INTO THE EXISTING SEWER.

BASIS OF PAYMENT

TEE OR WYE CONNECTIONS SHALL BE PAID FOR AT THE CONTRACT UNIT PRICE EACH FOR STORM SEWER TEE OR WYE OF THE TYPE AND SIZE SPECIFIED IN THE PLANS. THIS PRICE SHALL INCLUDE ALL EXCAVATION OF THE TRENCH, REMOVAL OF THE EXISTING STORM SEWER, FURNISHING AND INSTALLING THE SPECIFIED TEE OR WYE SECTION, FURNISHING AND INSTALLING THE REQUIRED CONCRETE COLLAR, AND ALL OTHER MATERIAL NECESSARY TO COMPLETE THIS WORK AS SHOWN AND SPECIFIED.

REMOVAL AND REINSTALLATION OF EXISTING STORM SEWER ADJACENT TO THE PROPOSED TEE OR WYE SECTION, FOR THE PURPOSE OF FACILITATING THE INSTALLATION OF THE TEE OR WYE SECTION, WILL NOT BE PAID FOR SEPARATELY BUT SHALL BE INCLUDED IN THE UNIT PRICE BID FOR THE WORK.

TRENCH BACKFILL, EXCAVATION IN ROCK AND REMOVAL AND REPLACEMENT OF UNSUITABLE MATERIAL BELOW PLAN BEDDING GRADE WILL BE PAID FOR SEPARATELY.

CONCRETE COLLAR FOR CONNECTING A PROPOSED STORM SEWER TO AN EXISTING STORM SEWER WILL NOT BE PAID FOR SEPARATELY BUT SHALL BE INCLUDED IN THE COST OF THE PROPOSED STORM SEWER.

ALL DIMENSIONS ARE IN INCHES (MILLIMETERS) UNLESS OTHERWISE SHOWN.

FILE NAME = W:\diststd\22x34\bd07.dgn	USER NAME = gajlonobt	DESIGNED - M. DE YONG	REVISED - M. DE YONG 05-08-92
		DRAWN -	REVISED - R. SHAH 09-09-94
	PLOT SCALE = 50.000' / IN.	CHECKED -	REVISED - R. SHAH 10-25-94
	PLOT DATE = 1/4/2008	DATE - 07-25-90	REVISED - R. SHAH 06-12-96

STATE OF ILLINOIS
DEPARTMENT OF TRANSPORTATION

DETAIL OF STORM SEWER
CONNECTION TO EXISTING SEWER

SCALE: NONE SHEET NO. 1 OF 1 SHEETS STA. TO STA.

F.A. RTE.	SECTION	COUNTY	TOTAL SHEETS	SHEET NO.
		DUPAGE	62	57
BD500-01 (BD-7)		CONTRACT NO.		
FED. ROAD DIST. NO. 1 ILLINOIS FED. AID PROJECT				

NOT FOR

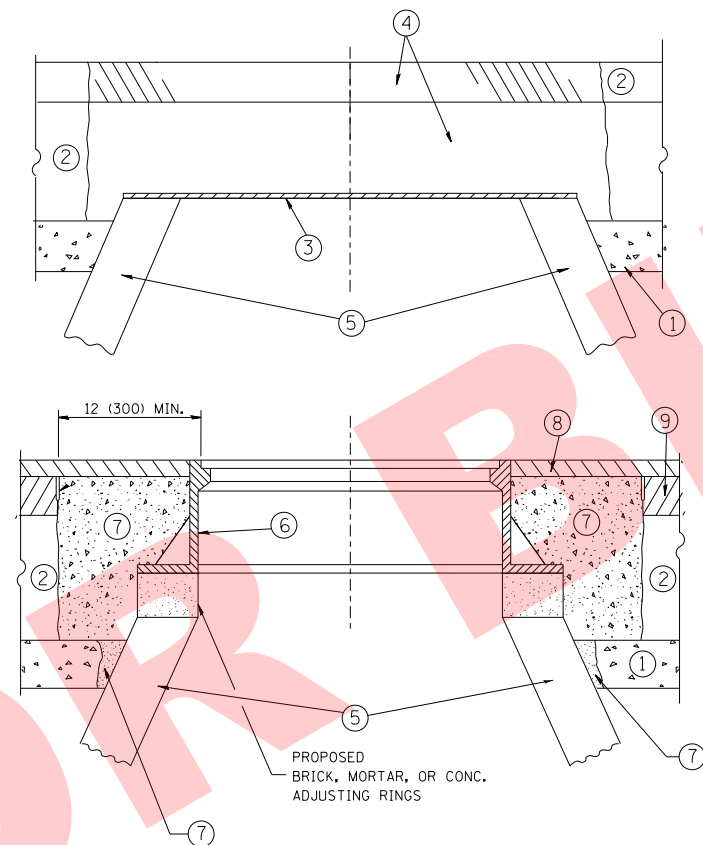

CONSTRUCTION PROCEDURES

- STAGE 1 (BEFORE PAVEMENT MILLING)**
- A) REMOVE A MINIMUM OF 12 (300) OF THE PAVEMENT FROM AROUND THE STRUCTURE.
 - B) REMOVE THE EXISTING FRAME AND LID FROM THE STRUCTURE.
 - C) COVER THE STRUCTURE OPENING WITH A 36 (900) DIAMETER METAL PLATE.
 - D) BACKFILL WITH CRUSHED STONE AND A MINIMUM 1/2 (40) THICK HMA SURFACE MIX APPROVED BY THE ENGINEER.
- STAGE 2 (AFTER PAVEMENT MILLING)**
- A) REMOVE THE HMA SURFACE MIX AND CRUSHED STONE.
 - B) INSTALL THE FRAME AND LID; ADJUST THE FRAME TO ITS FINAL SURFACE ELEVATION.
 - C) THE SURROUNDING SPACE SHALL BE FILLED WITH CLASS PP-1* CONCRETE TO THE ELEVATION OF THE SURFACE OF THE EXISTING BASE COURSE OR THE BINDER COURSE.
- * UNLESS OTHERWISE SPECIFIED IN THE PLANS.

THE PROCEDURE EXPLAINED ABOVE SHALL CONFORM TO THE APPLICABLE PORTIONS OF SECTIONS 353, 406, 602, AND 603 OF THE STANDARD SPECIFICATIONS EXCEPT THAT "THE CONTRACTOR SHALL ADJUST THE STRUCTURES TO THE FINISHED PAVEMENT ELEVATION NO MORE THAN 5 CALENDAR DAYS PRIOR TO PLACEMENT OF THE FINAL LIFT OF SURFACE UNLESS APPROVED BY THE ENGINEER."

LEGEND

- ① SUB-BASE GRANULAR MATERIAL
- ⑥ FRAME AND LID (SEE NOTES)
- ② EXISTING PAVEMENT
- ⑦ CLASS PP-1* CONCRETE
- ③ 36 (900) DIAMETER METAL PLATE
- ⑧ PROPOSED HMA SURFACE COURSE
- ④ PROPOSED CRUSHED STONE AND HMA SURFACE MIX
- ⑨ PROPOSED HMA BINDER COURSE
- ⑤ EXISTING STRUCTURE

NOTES:

EXISTING BROKEN FRAMES AND LIDS SHALL BE REMOVED AND DISPOSED OF BY THE CONTRACTOR AND SHALL BE REPLACED AS DIRECTED BY THE ENGINEER. REPLACEMENT FRAMES AND LIDS WILL BE PAID FOR IN ACCORDANCE WITH ARTICLE 109.04 OF THE STANDARD SPECIFICATIONS UNLESS A SEPARATE PAY ITEM HAS BEEN PROVIDED.

IF THE EXISTING LIDS ARE OPEN, THE FRAME WILL BE ADJUSTED TO THE ELEVATION OF THE MILLED PAVEMENT SURFACE PRIOR TO THE MILLING OPERATION. THE FRAME WILL NOT BE REMOVED AND COVERED BY THE METAL PLATE.

CITY OF CHICAGO CASTINGS ARE THE PROPERTY OF THE CITY AND THE CONTRACTOR SHALL NOTIFY THE CITY FOR REMOVAL AND DISPOSITION OF THE CASTINGS.

THE METAL PLATE USED TO COVER THE STRUCTURE SHALL REMAIN THE PROPERTY OF THE CONTRACTOR.

WHEN STRUCTURES ARE TO BE ADJUSTED OR RECONSTRUCTED, THE LOWERING AND RAISING OF THE FRAMES AND LIDS WILL NOT BE PAID FOR SEPARATELY BUT WILL BE INCLUDED IN THE COST OF THE CORRESPONDING PAY ITEM.

LOCATION OF STRUCTURES:

THE CONTRACTOR WILL BE REQUIRED TO KEEP A RECORD OF THE LOCATIONS OF THE BURIED STRUCTURES ACCORDING TO THE STATION AND DISTANCE LEFT OR RIGHT OF THE CENTERLINE OF PAVEMENT. UPON COMPLETION OF THE WORK, THE CONTRACTOR WILL DELIVER THE RECORD TO THE ENGINEER.

BASIS OF PAYMENT:

REMOVING FRAMES AND LIDS ON DRAINAGE AND UTILITY STRUCTURES IN THE PAVEMENT PRIOR TO MILLING, AND ADJUSTING TO FINAL GRADE PRIOR TO PLACING THE SURFACE COURSE, WILL BE PAID FOR AT THE CONTRACT UNIT PRICE EACH FOR "FRAMES AND LIDS TO BE ADJUSTED (SPECIAL)."

THIS WORK WILL NOT BE PAID FOR WHEN DRAINAGE AND UTILITY STRUCTURES ARE SPECIFIED FOR PAYMENT AS STRUCTURE RECONSTRUCTION.

NEW FRAMES AND LIDS, WHEN SPECIFIED, WILL BE PAID FOR SEPARATELY.

DETAILS FOR FRAMES AND LIDS ADJUSTMENT WITH MILLING

ALL DIMENSIONS ARE IN INCHES (MILLIMETERS) UNLESS OTHERWISE SHOWN

FILE NAME =	USER NAME = bauerdl	DESIGNED - R. SHAH	REVISED - R. WIEDEMAN 05-14-04
ct:\pwork\pwork\baerd1\d0108315\bd08.dgn		DRAWN -	REVISED - R. BORO 01-01-07
	PLOT SCALE = 1/68.5000 ' / m	CHECKED -	REVISED - R. BORO 03-09-11
	PLOT DATE = 12/6/2011	DATE - 10-25-94	REVISED - R. BORO 12-06-11

**STATE OF ILLINOIS
DEPARTMENT OF TRANSPORTATION**

DETAILS FOR FRAMES AND LIDS ADJUSTMENT WITH MILLING			
SCALE: NONE	SHEET NO. 1 OF 1 SHEETS	STA.	TO STA.

F.A. RTE.	SECTION	COUNTY	TOTAL SHEETS	SHEET NO.
			62	58
BD600-03 (BD-8)			CONTRACT NO.	
FED. ROAD DIST. NO. 1 ILLINOIS FED. AID PROJECT				

VARIABLE - TO MEET EXISTING DIMENSIONS AND FIELD CONDITIONS (SEE NOTE ②)

PROP. CONC. CURB OR CURB AND GUTTER REPLACEMENT IN ACCORDANCE WITH STATE STANDARD 606001. (SEE NOTE ②)

SAW CUT FULL DEPTH - INCLUDED IN THE COST OF SIDEWALK, DRIVEWAY OR MEDIAN SURFACE REMOVAL PAY ITEM.

SEE STATE STANDARD 606001
EXISTING OR PROPOSED HMA SURFACE (IF APPLICABLE)

18" (450) MAX.

1/4" (5) **

EXISTING SIDEWALK, DRIVEWAY, MEDIAN SURFACE, SOD OR GROUND.

PROPOSED SIDEWALK, DRIVEWAY PAVEMENT, MEDIAN SURFACE OR SODDING SALT TOLERANT WITH TOP SOIL, 4" (100) SOD RESTORATION (SEE NOTE ①).

EXISTING CONCRETE PAVEMENT, CONCRETE BASE COURSE OR FLEXIBLE PAVEMENT

3" (75) MIN.

SUITABLE BACKFILL MATERIAL (INCLUDED IN THE COST OF CURB OR CURB AND GUTTER REMOVAL AND REPLACEMENT)

* 3" (75) MINIMUM FROM TOP AND BOTTOM OF THE CONCRETE PAVEMENT OR BASE COURSE.

** IF THE FINAL SURFACE OF THE PAVEMENT IS CONCRETE, THE GUTTER IS TO BE FLUSH WITH THE PAVEMENT.

PROPOSED 3/4" (20) PREFORMED EXPANSION JOINT AT CONCRETE SIDEWALKS, DRIVEWAYS, AND MEDIANS. (INCLUDED IN THE COST OF CURB OR CURB AND GUTTER REMOVAL AND REPLACEMENT.)

NOTE: ① SIDEWALK, DRIVEWAY PAVEMENT OR MEDIAN SURFACE SHALL BE SIMILAR TO THE MATERIAL BEING REMOVED AND WILL BE PAID FOR SEPARATELY.
SODDING, SALT TOLERANT AND TOP SOIL, FURNISH AND PLACE 4" WILL BE PAID FOR SEPARATELY.

UNSUITABLE SUB-BASE MATERIAL TO BE REMOVED, IF DIRECTED BY THE ENGINEER, SHALL BE REPLACED WITH EITHER SUB-BASE GRANULAR MATERIAL, TYPE B OR ADDITIONAL THICKNESS OF CONCRETE.

② FERTILIZER FOR THE PLACEMENT OF THE SOD IS NOT REQUIRED

REMOVAL AND REPLACEMENT 4" (100) OR LESS IS INCLUDED IN THE COST OF CURB OR CURB AND GUTTER REMOVAL AND REPLACEMENT.

③ CURB OR CURB AND GUTTER REPLACEMENT SHALL MATCH THE SHAPE OF THE EXISTING CURB OR CURB AND GUTTER UNLESS OTHERWISE SPECIFIED.

REMOVAL AND REPLACEMENT IN EXCESS OF 4" (100) WILL BE PAID FOR IN ACCORDANCE WITH ARTICLE 109.04 OF THE STANDARD SPECIFICATIONS.

④ FOR CURB OR CURB AND GUTTER REMOVAL AND REPLACEMENT ADJACENT TO FLEXIBLE PAVEMENT DELETE EPOXY COATED TIE BARS.

PROPOSED #6 (20) EPOXY COATED TIE BARS 24" (600) LONG AT 24" (600) CENTERS WILL NOT BE PAID FOR SEPARATELY. DELETE EPOXY COATED TIE BARS IF EXISTING TIE BARS ARE USABLE AS DETERMINED BY THE ENGINEER. (SEE NOTE ③).

⑤ LONGITUDINAL BARS, IF ENCOUNTERED IN THE EXISTING CURB OR CURB AND GUTTER, ARE NOT TO BE REPLACED. CUTTING AND REMOVING LONGITUDINAL BARS SHALL BE INCLUDED IN THE COST OF CURB OR CURB AND GUTTER REMOVAL AND REPLACEMENT.

⑥ THE COST OF HMA SURFACE REMOVAL IN THE EXISTING GUTTER FLAG SHALL BE INCLUDED IN THE COST OF THE CURB AND GUTTER REMOVAL AND REPLACEMENT.

BASIS OF PAYMENT:
THIS WORK WILL BE PAID FOR AT THE CONTRACT UNIT PRICE PER FOOT (METER) FOR "CURB REMOVAL AND REPLACEMENT" OR "COMBINATION CONCRETE CURB AND GUTTER REMOVAL AND REPLACEMENT".

⑦ THE REMOVAL AND REPLACEMENT OF THE EXISTING CURB OR CURB AND GUTTER SHALL BE DONE IN ACCORDANCE WITH THE APPLICABLE PORTIONS OF SECTION 440 AND 606 OF THE STANDARD SPECIFICATIONS.

⑧ THE LOCATIONS OF REMOVAL AND REPLACEMENT OF EXISTING CURB OR CURB AND GUTTER SHALL BE DETERMINED BY THE RESIDENT ENGINEER AT THE TIME OF CONSTRUCTION.

CURB OR CURB AND GUTTER REMOVAL AND REPLACEMENT

ALL DIMENSIONS ARE IN INCHES (MILLIMETERS) UNLESS OTHERWISE SHOWN.

FILE NAME =	USER NAME = drivakosgn	DESIGNED - A. HOUSEH	REVISED - R. SHAH 10-03-96	STATE OF ILLINOIS DEPARTMENT OF TRANSPORTATION	CURB OR CURB AND GUTTER REMOVAL AND REPLACEMENT	F.A. RTE.	SECTION	COUNTY	TOTAL SHEETS	SHEET NO.	
ct:\pw\work\p1dot\drivakosgn\0108315\bd24.dgn	DRAWN -	REVISED - A. ABBAS 03-21-97	REVISED - M. GOMEZ 01-22-01			SCALE: NONE	SHEET NO. 1 OF 1 SHEETS	STA.	TO STA.	BD600-06 (BD-24)	CONTRACT NO.
PLOT SCALE = 50.000' / IN.	CHECKED -	REVISED - R. BORO 12-15-09								FED. ROAD DIST. NO. 1	ILLINOIS FED. AID PROJECT
PLOT DATE = 12/15/2009	DATE - 03-11-94										

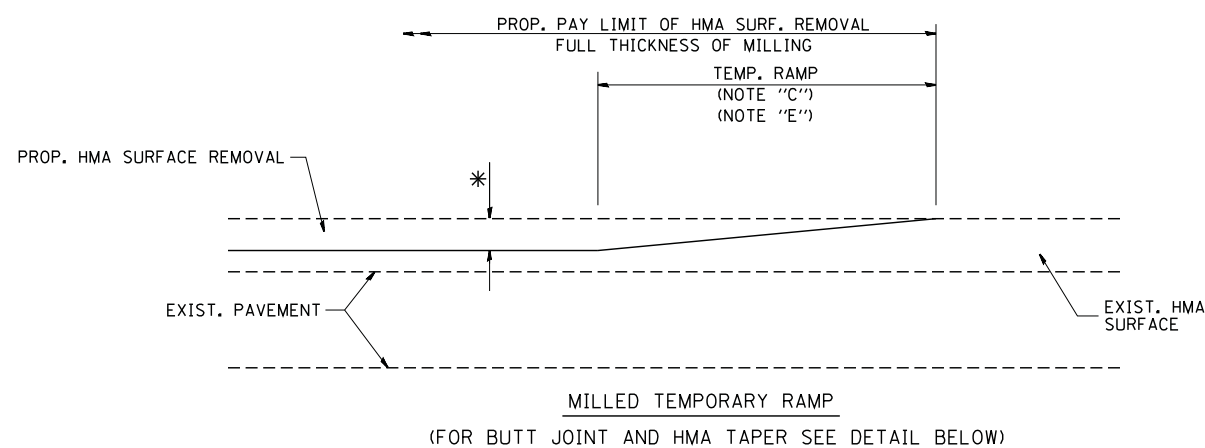

OPTION 1

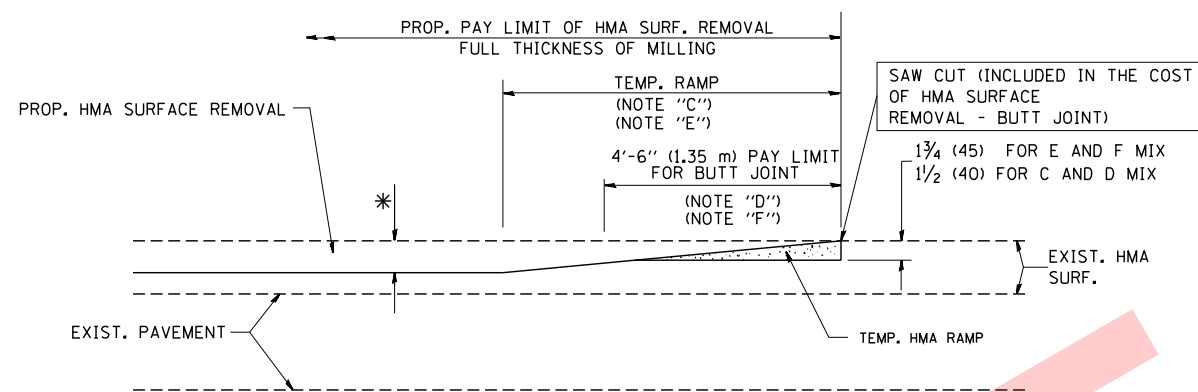

OPTION 2

TYPICAL TEMPORARY RAMP

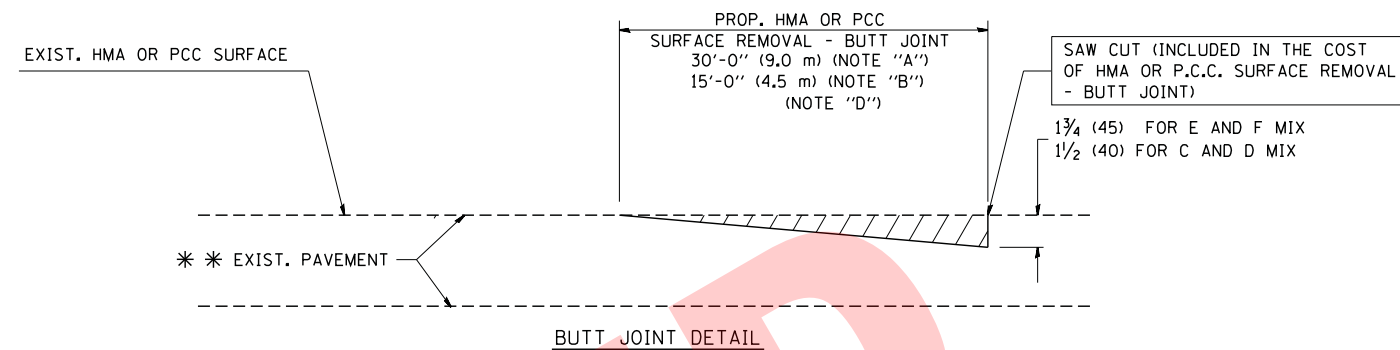

BUTT JOINT DETAIL

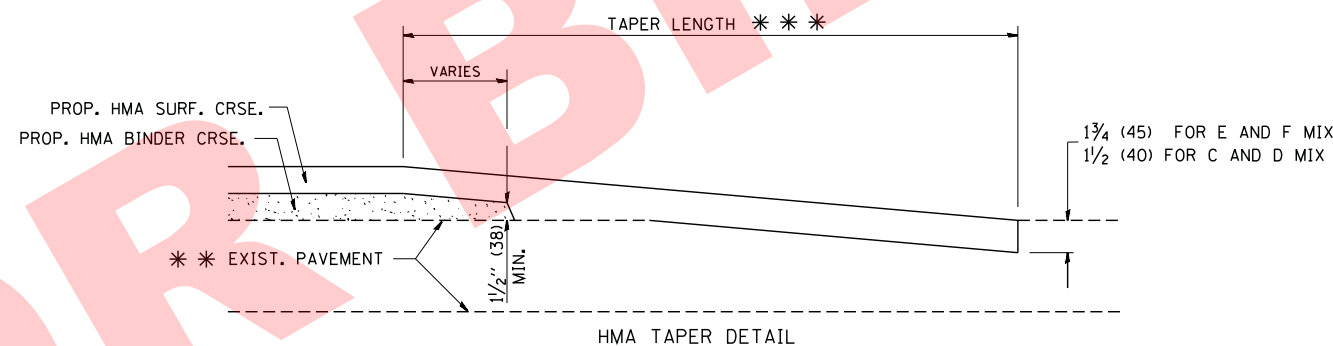

HMA TAPER DETAIL

TYPICAL BUTT JOINT AND HMA TAPER FOR RESURFACING ONLY

*** PC CONCRETE, HMA OR HMA RESURFACED PAVEMENT.

NOTES

- A: MAINLINE ROADWAYS AND MAJOR SIDE ROADS.
- B: MINOR SIDE ROADS.
- C: THE TEMP. RAMP SHALL BE CONSTRUCTED IMMEDIATELY UPON REMOVAL OF THE EXISTING HMA SURFACE.
- D: THE BUTT JOINT SHALL BE CONSTRUCTED IMMEDIATELY PRIOR TO PLACING THE PROPOSED HMA COURSES.
- E: TAPER THE TEMP. RAMP AT A RATE OF 3'-0" (900 mm) PER 1 INCH (25 mm) OF MILLING THICKNESS.
- F: INSTALLATION AND REMOVAL OF THE 4'-6" (1.35 m) TEMP. RAMP IS INCLUDED IN COST OF HMA SURFACE REMOVAL - BUTT JOINT
- G: SEE ARTICLE 406.08 AND 406.14 OF THE STANDARD SPECIFICATIONS FOR "HMA AND/OR PCC SURFACE REMOVAL, BUTT JOINT".

* SEE TYPICAL SECTIONS FOR MILLING THICKNESS.

*** 20'-0" (6.1 m) PER 1 (25) RESURFACING (NOTE "A")
10'-0" (3.0 m) PER 1 (25) RESURFACING (NOTE "B")

BASIS OF PAYMENT:

THE BUTT JOINT WILL BE PAID FOR AT THE CONTRACT UNIT PRICE PER SQUARE YARD (SQUARE METER) FOR "HOT-MIX ASPHALT SURFACE REMOVAL - BUTT JOINT" OR FOR "PORTLAND CEMENT CONCRETE SURFACE REMOVAL - BUTT JOINT".

ALL DIMENSIONS ARE IN INCHES (MILLIMETERS) UNLESS OTHERWISE SHOWN.

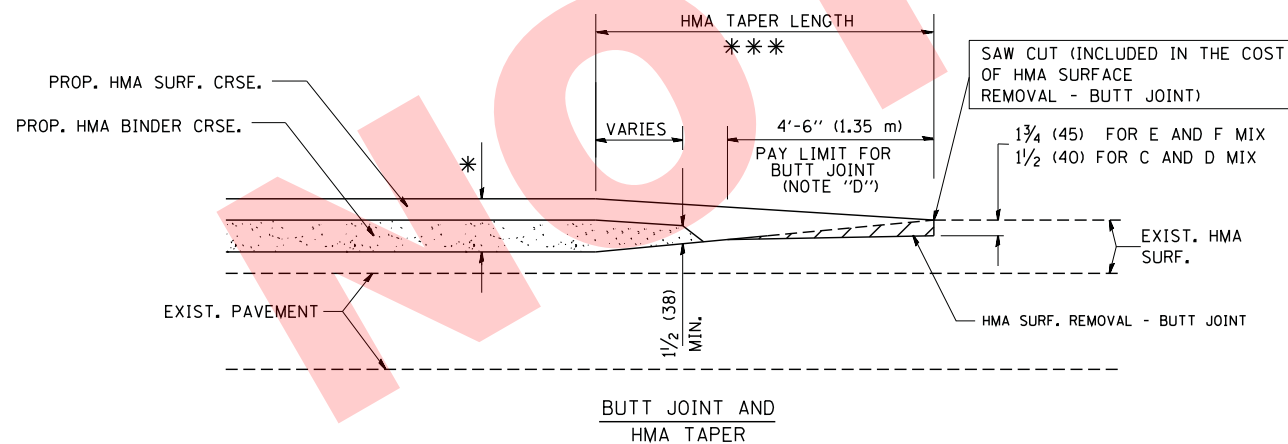

TYPICAL BUTT JOINT AND HMA TAPER FOR MILLING AND RESURFACING

FILE NAME = W:\diststd\22x34\bd32.dgn	USER NAME = gaglionobt	DESIGNED - M. DE YONG	REVISED - R. SHAH 10-25-94
		DRAWN -	REVISED - A. ABBAS 03-21-97
	PLOT SCALE = 50.0000' / IN.	CHECKED -	REVISED - M. GOMEZ 04-06-01
	PLOT DATE = 1/4/2008	DATE - 06-13-90	REVISED - R. BORO 01-01-07

**STATE OF ILLINOIS
DEPARTMENT OF TRANSPORTATION**

**BUTT JOINT AND
HMA TAPER DETAILS**

SCALE: NONE SHEET NO. 1 OF 1 SHEETS STA. TO STA.

F.A. RTE.	SECTION	COUNTY	TOTAL SHEETS	SHEET NO.
		DUPAGE	62	60
BD400-05 BD32			CONTRACT NO.	
FED. ROAD DIST. NO. 1 ILLINOIS FED. AID PROJECT				

NOT FOR BIDDING

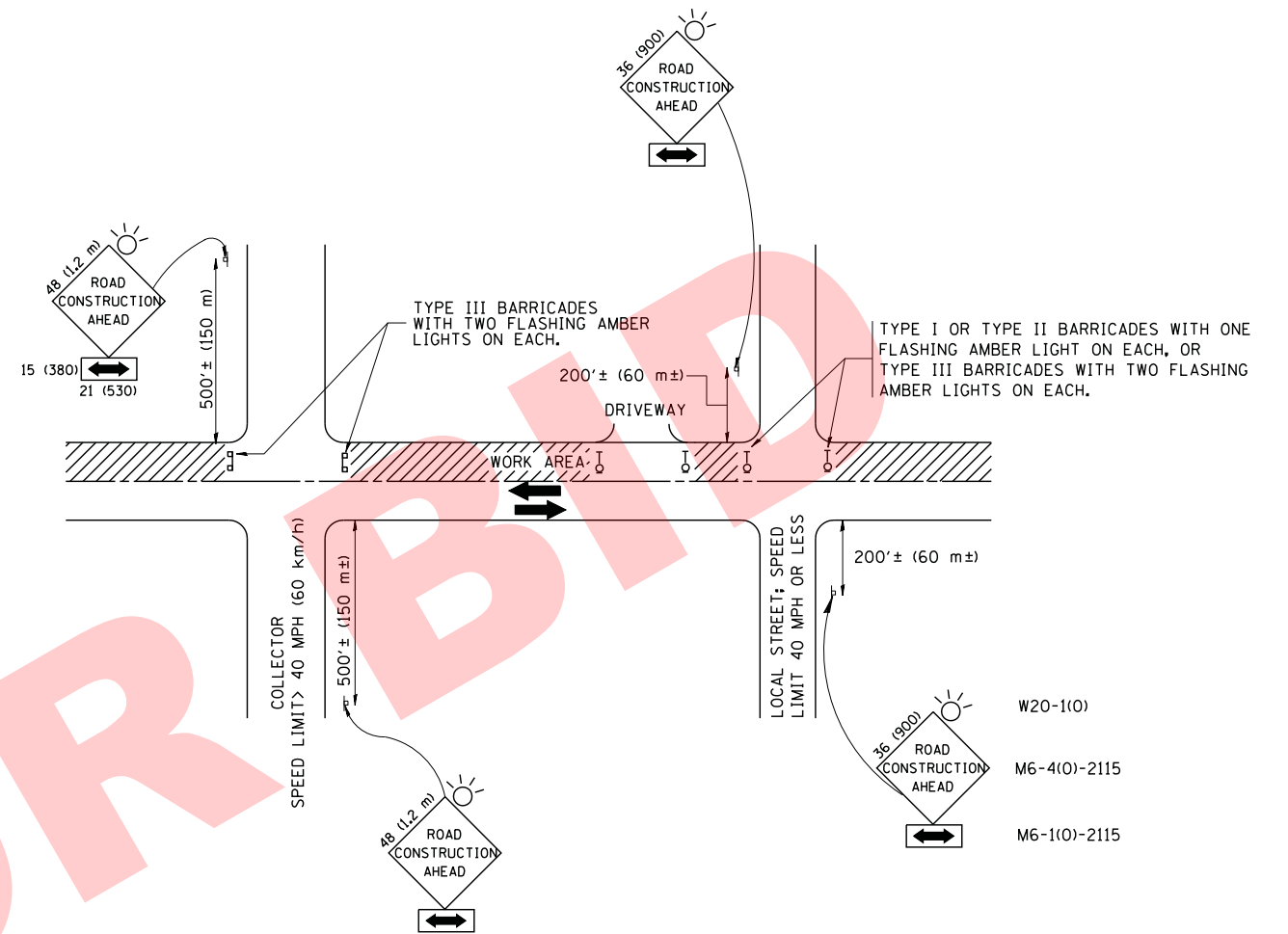

TRAFFIC CONTROL AND PROTECTION FOR SIDE ROADS, INTERSECTIONS, AND DRIVEWAYS

NOTES:

- A. FOR NO LANE RESTRICTION ON THE SIDE ROAD OR DRIVEWAYS
 1. SIDE ROAD WITH A SPEED LIMIT OF 40 MPH (60 km/h) OR LESS AS SHOWN ON THE DRAWING AND AS DIRECTED BY THE ENGINEER:
 - a) ONE **ROAD CONSTRUCTION AHEAD** SIGN 36 x 36 (900x900) WITH A FLASHER AND FLAG MOUNTED ON IT APPROXIMATELY 200' (60 m) IN ADVANCE OF THE MAIN ROUTE.
 - b) THE CLOSED PORTION OF THE MAIN ROUTE SHALL BE PROTECTED BY BLOCKING WITH TYPE I, TYPE II OR TYPE III BARRICADES, 1/3 OF THE CROSS SECTION OF THE CLOSED PORTION.
 2. SIDE ROAD WITH A SPEED LIMIT GREATER THAN 40 MPH (60 km/h) AS SHOWN ON THE DRAWING AND AS DIRECTED BY THE ENGINEER:
 - a) ONE **ROAD CONSTRUCTION AHEAD** SIGN 48 x 48 (1.2 m x 1.2 m) WITH A FLASHER MOUNTED ON IT APPROXIMATELY 500' (150 m) IN ADVANCE OF THE MAIN ROUTE.
 - b) THE CLOSED PORTION OF THE MAIN ROUTE SHALL BE PROTECTED BY BLOCKING WITH TYPE III BARRICADES, 1/2 OF THE CROSS SECTION OF THE CLOSED PORTION.
 3. WHEN THE SIDE ROAD LIES BETWEEN THE BEGINNING OF THE MAINLINE SIGNING AND THE WORK ZONE, A SINGLE HEADED ARROW (M6-1) SHALL BE USED IN LIEU OF THE DOUBLE HEADED ARROW (M6-4).
- B. FOR A LANE CLOSURE ON A SIDE ROAD OR DRIVEWAY:

USE APPLICABLE PORTIONS OF THE TYPICAL APPLICATION OF TRAFFIC CONTROL DEVICES (STD. 701501, STD. 701606 OR THE APPROPRIATE STANDARD). THE SPACING OF SIGNS AND BARRICADES SHALL BE ADJUSTED FOR FIELD CONDITIONS AS DIRECTED BY THE ENGINEER. THE DIRECTIONAL ARROW SHALL BE COVERED OR REMOVED WHEN NO LONGER CONSISTENT WITH THE SIDE ROAD LANE CLOSURE.
- C. ADVANCE WARNING SIGNS ARE TO BE OMITTED ON DRIVEWAY UNLESS OTHERWISE NOTED.
- D. THE TRAFFIC CONTROL AND PROTECTION FOR SIDE ROADS, INTERSECTIONS, AND DRIVEWAYS SHALL BE INCIDENTAL TO THE COST OF SPECIFIED TRAFFIC CONTROL STANDARDS OR ITEMS.

All dimensions are in millimeters (inches) unless otherwise shown.

FILE NAME = W:\diststd\22x34\tc10.dgn	USER NAME = geglionobt	DESIGNED - LHA	REVISED - J. OBERLE 10-18-95
		DRAWN -	REVISED - A. HOUSEH 03-06-96
	PLOT SCALE = 50.000' / IN.	CHECKED -	REVISED - A. HOUSEH 10-15-96
	PLOT DATE = 1/4/2008	DATE - 06-89	REVISED - T. RAMMACHER 01-06-00

**STATE OF ILLINOIS
DEPARTMENT OF TRANSPORTATION**

**TRAFFIC CONTROL AND PROTECTION FOR
SIDE ROADS, INTERSECTIONS, AND DRIVEWAYS**

SCALE: NONE SHEET NO. 1 OF 1 SHEETS STA. TO STA.

F.A. RTE.	SECTION	COUNTY	TOTAL SHEETS	SHEET NO.
			62	61
TC-10			CONTRACT NO.	
FED. ROAD DIST. NO. 1 ILLINOIS FED. AID PROJECT				

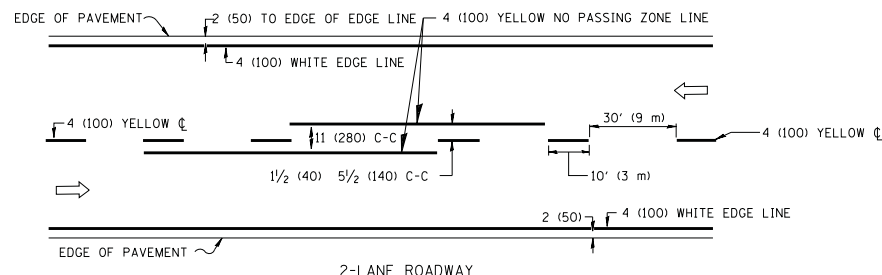

2-LANE ROADWAY

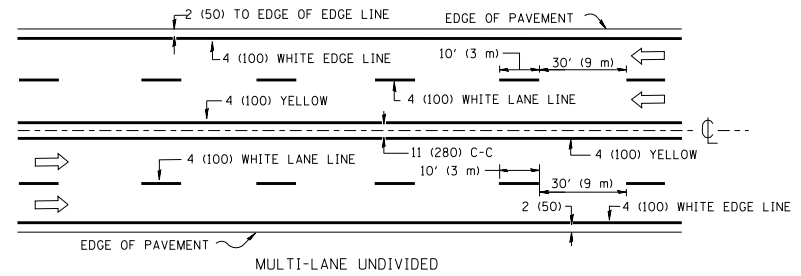

MULTI-LANE UNDIVIDED

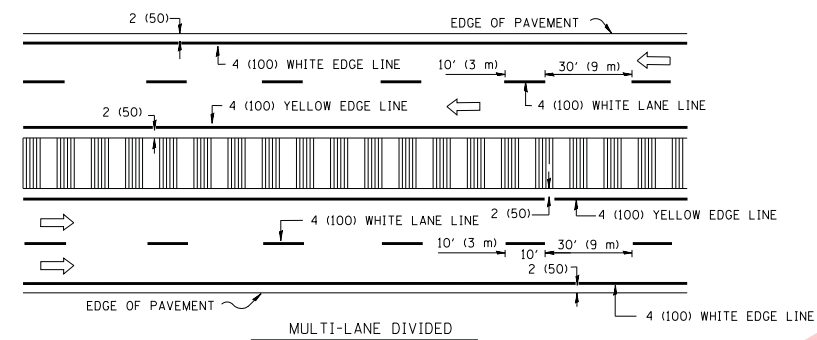

MULTI-LANE DIVIDED WITH MOUNTABLE MEDIAN

NOTE: MEDIANS WITH BARRIER CURB DO NOT REQUIRE AN EDGE LINE

TYPICAL LANE AND EDGE LINE MARKING

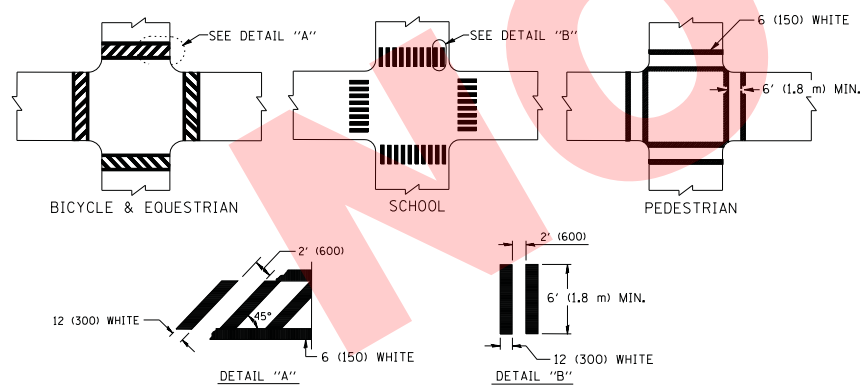

TYPICAL CROSSWALK MARKING

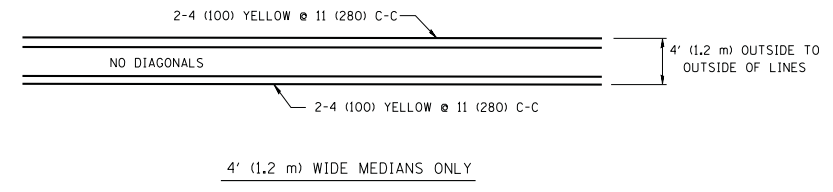

4' (1.2 m) WIDE MEDIANS ONLY

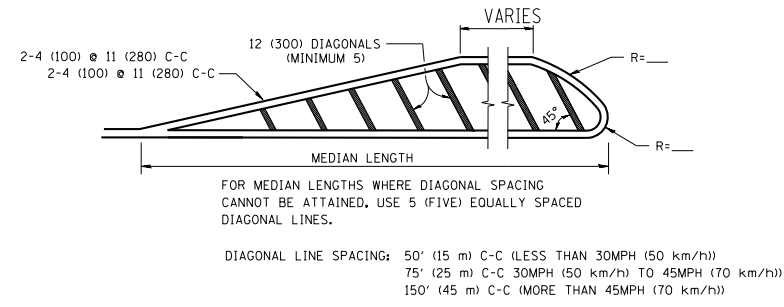

MEDIANS OVER 4' (1.2 m) WIDE

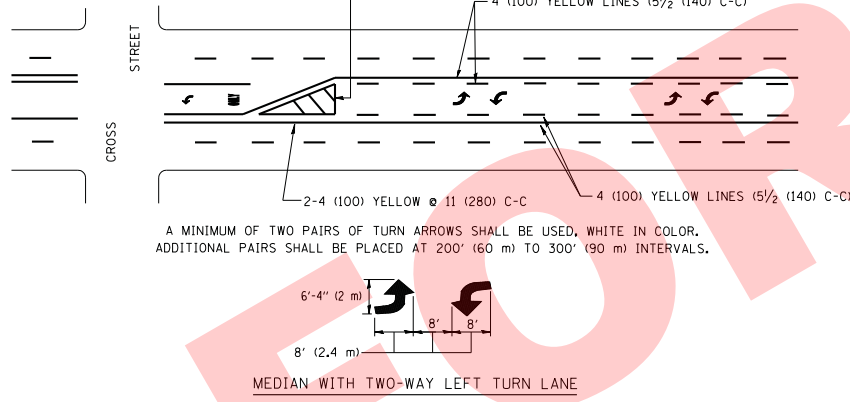

TYPICAL PAINTED MEDIAN MARKING

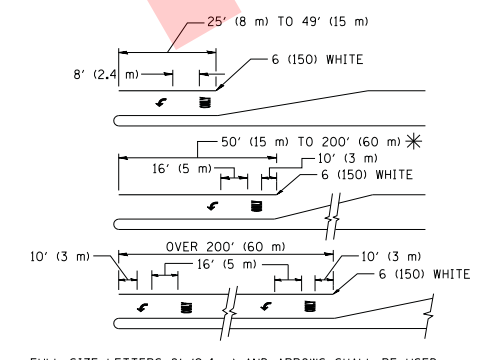

TYPICAL LEFT (OR RIGHT) TURN LANE

FULL SIZE LETTERS 8' (2.4 m) AND ARROWS SHALL BE USED.
 AREA = 15.6 SQ. FT. (1.5 m²) ONLY AREA = 20.8 SQ. FT. (1.9 m²)
 * TURN LANES IN EXCESS OF 400' (120 m) IN LENGTH MAY HAVE AN ADDITIONAL SET OF ARROW - "ONLY" INSTALLED MIDWAY BETWEEN THE OTHER TWO SETS OF ARROW - "ONLY".

TYPICAL TURN LANE MARKING

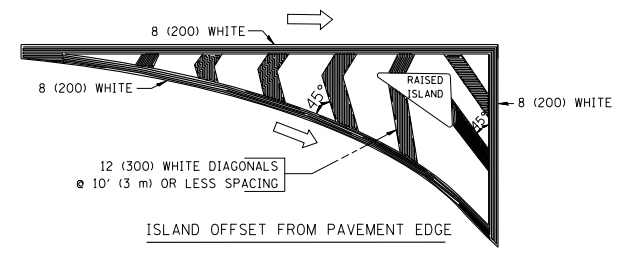

ISLAND OFFSET FROM PAVEMENT EDGE

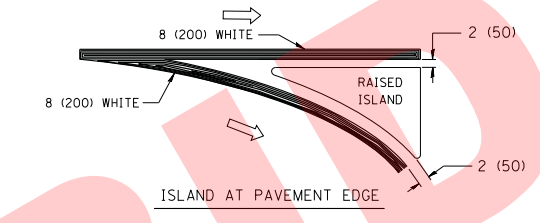

TYPICAL ISLAND MARKING

TYPE OF MARKING	WIDTH OF LINE	PATTERN	COLOR	SPACING / REMARKS
CENTERLINE ON 2 LANE PAVEMENT	4 (100)	SKIP-DASH	YELLOW	10' (3 m) LINE WITH 30' (9 m) SPACE
CENTERLINE ON MULTI-LANE UNDIVIDED PAVEMENT	2 @ 4 (100)	SOLID	YELLOW	11 (280) C-C
NO PASSING ZONE LINES FOR ONE DIRECTION FOR BOTH DIRECTIONS	4 (100) 2 @ 4 (100)	SOLID SOLID	YELLOW YELLOW	5/2 (140) C-C FROM SKIP-DASH CENTERLINE 11 (280) C-C OMIT SKIP-DASH CENTERLINE BETWEEN
LANE LINES	4 (100) 5 (125) ON FREEWAYS	SKIP-DASH SKIP-DASH	WHITE WHITE	10' (3 m) LINE WITH 30' (9 m) SPACE
DOTTED LINES (EXTENSIONS OF CENTER, LANE OR TURN LANE MARKINGS)	SAME AS LINE BEING EXTENDED	SKIP-DASH	SAME AS LINE BEING EXTENDED	2' (600) LINE WITH 6' (1.8 m) SPACE
EDGE LINES	4 (100)	SOLID	YELLOW-LEFT WHITE-RIGHT	OUTLINE MOUNTABLE MEDIANS IN YELLOW; EDGE LINES ARE NOT USED NEXT TO BARRIER CURB
TURN LANE MARKINGS	6 (150) LINE; FULL SIZE LETTERS & SYMBOLS (8' (2.4m))	SOLID	WHITE	SEE TYPICAL TURN LANE MARKING DETAIL
TWO WAY LEFT TURN MARKING	2 @ 4 (100) EACH DIRECTION 8' (2.4m) LEFT ARROW	SKIP-DASH AND SOLID IN PAIRS	YELLOW WHITE	10' (3 m) LINE WITH 30' (9 m) SPACE FOR SKIP-DASH; 5/2 (140) C-C BETWEEN SOLID LINE AND SKIP-DASH LINE SEE TYPICAL TWO-WAY LEFT TURN MARKING DETAIL
CROSSWALK LINES (PEDESTRIAN) A. DIAGONALS (BIKE & EQUESTRIAN) B. LONGITUDINAL BARS (SCHOOL)	2 @ 6 (150) 12 (300) @ 45° 12 (300) @ 90°	SOLID SOLID SOLID	WHITE WHITE WHITE	NOT LESS THAN 6' (1.8 m) APART 2' (600) APART 2' (600) APART SEE TYPICAL CROSSWALK MARKING DETAILS.
STOP LINES	24 (600)	SOLID	WHITE	PLACE 4' (1.2 m) IN ADVANCE OF AND PARALLEL TO CROSSWALK, IF PRESENT. OTHERWISE, PLACE AT DESIRED STOPPING POINT, PARALLEL TO CROSSROAD CENTERLINE, WHERE POSSIBLE
PAINTED MEDIANS	2 @ 4 (100) WITH 12 (300) DIAGONALS @ 45° NO DIAGONALS USED FOR 4' (1.2 m) WIDE MEDIANS	SOLID	YELLOW; TWO WAY TRAFFIC WHITE; ONE WAY TRAFFIC	11 (280) C-C FOR THE DOUBLE LINE SEE TYPICAL PAINTED MEDIAN MARKING.
GORE MARKING AND CHANNELIZING LINES	8 (200) WITH 12 (300) DIAGONALS @ 45°	SOLID	WHITE	DIAGONALS: 15' (4.5 m) C-C (LESS THAN 30MPH (50 km/h)) 20' (6 m) C-C (30MPH (50 km/h) TO 45MPH (70 km/h)) 30' (9 m) C-C (OVER 45MPH (70 km/h))
RAILROAD CROSSING	24 (600) TRANSVERSE LINES; "RR" 15 6' (1.8 m) LETTERS; 16 (400) LINE FOR "X"	SOLID	WHITE	SEE STATE STANDARD 780001 AREA OF: "R"=3.6 SQ. FT. (0.33 m ²) EACH "X"=54.0 SQ. FT. (5.0 m ²)
SHOULDER DIAGONALS	12 (300) @ 45°	SOLID	WHITE - RIGHT YELLOW - LEFT	50' (15 m) C-C (LESS THAN 30MPH (50 km/h)) 75' (25 m) C-C (30 MPH (50 km/h) TO 45MPH (70 km/h)) 150' (45 m) C-C (OVER 45MPH (70 km/h))

FOR FURTHER DETAILS ON PAVEMENT MARKING REFER TO STANDARD SPECIFICATIONS FOR ROAD AND BRIDGE CONSTRUCTION AND STATE STANDARD 780001.

All dimensions are in inches (millimeters) unless otherwise shown.

FILE NAME =	USER NAME = drivakosgn	DESIGNED - EVERS	REVISED -T. RAMMACHER 10-27-94
ca:\pwwork\pwwork\drivakosgn\d0108315\to3.dgn		DRAWN -	REVISED -C. JUCIUS 09-09-09
	PLOT SCALE = 50.000' / IN.	CHECKED -	REVISED -
	PLOT DATE = 9/9/2009	DATE - 03-19-90	REVISED -

STATE OF ILLINOIS
DEPARTMENT OF TRANSPORTATION

DISTRICT ONE			
TYPICAL PAVEMENT MARKINGS			
SCALE: NONE	SHEET NO. 1 OF 1 SHEETS	STA.	TO STA.

F.A. RTE.	SECTION	COUNTY	TOTAL SHEETS	SHEET NO.
		DUPAGE	62	62
TC-13		CONTRACT NO.		
FED. ROAD DIST. NO. 1 ILLINOIS FED. AID PROJECT				