



# Village of Villa Park

## Local Public Agency Formal Contract Proposal

### 2015 Street Resurfacing Project

PROPOSAL SUBMITTED BY		
Contractor's Name		
Street	P.O. Box	
City	State	Zip Code

STATE OF ILLINOIS

COUNTY OF DuPage  
Village of Villa Park  
 (Name of City, Village, Town or Road District)

FOR THE IMPROVEMENT OF

STREET NAME OR ROUTE NO. Various Streets  
 SECTION NO. N/A  
 TYPES OF FUNDS Local

SPECIFICATIONS (required)

PLANS (required)

**For Municipal Projects**  
 Submitted/Approved/Passed

Mayor  President of Board of Trustees  Municipal Official

\_\_\_\_\_

Date

**Department of Transportation**

Released for bid based on limited review

\_\_\_\_\_

Regional Engineer

\_\_\_\_\_

Date

**For County and Road District Projects**  
 Submitted/Approved

\_\_\_\_\_

Highway Commissioner

\_\_\_\_\_

Date

Submitted/Approved

\_\_\_\_\_

County Engineer/Superintendent of Highways

\_\_\_\_\_

Date

**Note:** All proposal documents, including Proposal Guaranty Checks or Proposal Bid Bonds, should be stapled together to prevent loss when bids are processed.

NOT FOR BID

RETURN WITH BID

NOTICE TO BIDDERS

County DuPage
Local Public Agency Village of Villa Park
Section Number N/A
Route Various Streets

Sealed proposals for the improvement described below will be received at the office of Director of Public Works ,
11 W. Home Ave., Villa Park, IL 60181 until 10:00 AM on June 23, 2015
Address Time Date

Sealed proposals will be opened and read publicly at the office of Public Works Director
11 W. Home Ave., Villa Park, IL 60181 at 10:00 AM on June 23, 2015
Address Time Date

DESCRIPTION OF WORK

Name 2015 Street Resurfacing Program Length: 16,263 feet ( 3.08 miles)
Location Various Streets within the Village of Villa Park
Proposed Improvement HMA and PCC surface removal with Leveling Binder and HMA surface replacement, HMA and PCC
patching, misc. repairs, structure adjustments, striping, and necessary restoration

1. Plans and proposal forms will be available in the office of Villa Park Public Works, 11 W. Home Ave, Villa Park , IL 60181
for a non-refundable fee of \$20.00
Address

2. [ ] Prequalification

If checked, the 2 low bidders must file within 24 hours after the letting an "Affidavit of Availability" (Form BC 57), in duplicate, showing all uncompleted contracts awarded to them and all low bids pending award for Federal, State, County, Municipal and private work. One original shall be filed with the Awarding Authority and one original with the IDOT District Office.

3. The Awarding Authority reserves the right to waive technicalities and to reject any or all proposals as provided in BLRS Special Provision for Bidding Requirements and Conditions for Contract Proposals.

4. The following BLR Forms shall be returned by the bidder to the Awarding Authority:

- a. BLR 12200: Local Public Agency Formal Contract Proposal
b. BLR 12200a Schedule of Prices
c. BLR 12230: Proposal Bid Bond (if applicable)
d. BLR 12325: Apprenticeship or Training Program Certification
e. BLR 12326: Affidavit of Illinois Business Office

5. The quantities appearing in the bid schedule are approximate and are prepared for the comparison of bids. Payment to the Contractor will be made only for the actual quantities of work performed and accepted or materials furnished according to the contract. The scheduled quantities of work to be done and materials to be furnished may be increased, decreased or omitted as hereinafter provided.

6. Submission of a bid shall be conclusive assurance and warranty the bidder has examined the plans and understands all requirements for the performance of work. The bidder will be responsible for all errors in the proposal resulting from failure or neglect to conduct an in depth examination. The Awarding Authority will, in no case be responsible for any costs, expenses, losses or changes in anticipated profits resulting from such failure or neglect of the bidder.

7. The bidder shall take no advantage of any error or omission in the proposal and advertised contract.

8. If a special envelope is supplied by the Awarding Authority, each proposal should be submitted in that envelope furnished by the Awarding Agency and the blank spaces on the envelope shall be filled in correctly to clearly indicate its contents. When an envelope other than the special one furnished by the Awarding Authority is used, it shall be marked to clearly indicate its contents. When sent by mail, the sealed proposal shall be addressed to the Awarding Authority at the address and in care of the official in whose office the bids are to be received. All proposals shall be filed prior to the time and at the place specified in the Notice to Bidders. Proposals received after the time specified will be returned to the bidder unopened.

9. Permission will be given to a bidder to withdraw a proposal if the bidder makes the request in writing or in person before the time for opening proposals.

NOT FOR BID

RETURN WITH BID

PROPOSAL

County DuPage
Local Public Agency Village of Villa Park
Section Number N/A
Route Various Streets

- 1. Proposal of ... for the improvement of the above section by the construction of HMA and PCC surface removal with Leveling Binder and HMA surface replacement, patching, misc. repairs, structure adjustments, striping, and necessary restoration.
2. The plans for the proposed work are those prepared by Robinson Engineering, Ltd. and approved by the Village of Villa Park on June 5, 2015
3. The specifications referred to herein are those prepared by the Department of Transportation and designated as "Standard Specifications for Road and Bridge Construction" and the "Supplemental Specifications and Recurring Special Provisions" thereto, adopted and in effect on the date of invitation for bids.
4. The undersigned agrees to accept, as part of the contract, the applicable Special Provisions indicated on the "Check Sheet for Recurring Special Provisions" contained in this proposal.
5. The undersigned agrees to complete the work within 60 calendar days unless additional time is granted in accordance with the specifications.
6. A proposal guaranty in the proper amount, as specified in BLRS Special Provision for Bidding Requirements and Conditions for Contract Proposals, will be required. Bid Bonds will be allowed as a proposal guaranty. Accompanying this proposal is either a bid bond if allowed, on Department form BLR 12230 or a proposal guaranty check, complying with the specifications, made payable to: Village Treasurer of Villa Park, IL
The amount of the check is Five Percent (5%) of the Bid Amount
7. In the event that one proposal guaranty check is intended to cover two or more proposals, the amount must be equal to the sum of the proposal guaranties, which would be required for each individual proposal. If the proposal guaranty check is placed in another proposal, it will be found in the proposal for: Section Number N/A
8. The successful bidder at the time of execution of the contract will be required to deposit a contract bond for the full amount of the award. When a contract bond is not required, the proposal guaranty check will be held in lieu thereof. If this proposal is accepted and the undersigned fails to execute a contract and contract bond as required, it is hereby agreed that the Bid Bond or check shall be forfeited to the Awarding Authority.
9. Each pay item should have a unit price and a total price. If no total price is shown or if there is a discrepancy between the product of the unit price multiplied by the quantity, the unit price shall govern. If a unit price is omitted, the total price will be divided by the quantity in order to establish a unit price.
10. A bid will be declared unacceptable if neither a unit price nor a total price is shown.
11. The undersigned submits herewith the schedule of prices on BLR 12200a covering the work to be performed under this contract.
12. The undersigned further agrees that if awarded the contract for the sections contained in the combinations on BLR 12200a, the work shall be in accordance with the requirements of each individual proposal for the multiple bid specified in the Schedule for Multiple Bids below.

NOT FOR BID

**RETURN WITH BID**

**SCHEDULE OF PRICES**

County DuPage  
 Local Public Agency Village of Villa Park  
 Section N/A  
 Route Various Streets

**Schedule for Multiple Bids**

Combination Letter	Sections Included in Combinations	Total

**Schedule for Single Bid**

(For complete information covering these items, see plans and specifications)

Bidder's Proposal for making Entire Improvements

Item No.	Items	Unit	Quantity	Unit Price	Total
1	HOT-MIX ASPHALT SURFACE REMOVAL, VARIABLE DEPTH	SQ YD	16,221		
2	PCC SURFACE REMOVAL, VARIABLE DEPTH	SQ YD	29,852		
3	PORTLAND CEMENT CONCRETE SURFACE REMOVAL BUTT JOINT	SQ YD	789		
4	HOT MIX ASPHALT BASE COURSE WIDENING 4"	SQ YD	90		
5	HOT MIX ASPHALT SURFACE COURSE, MIX "D", N50	TON	3,879		
6	BITUMINOUS MATERIAL (PRIME COAT)	POUND	44,837		
7	LEVELING BINDER (MACHINE METHOD), N50	TON	682		
8	POLYMERIZED LEVELING BINDER (MACHINE METHOD), N50	TON	2,706		
9	AGGREGATE BASE COURSE, TYPE B, 10"	SQ YD	90		
10	AGGREGATE FOR TEMPORARY ACCESS	TON	100		
11	HMA DRIVEWAY 4"	SQ YD	635		
12	PCC DRIVEWAY PAVEMENT 6"	SQ YD	73		
13	DRIVEWAY PAVEMENT REMOVAL	SQ YD	775		
14	PREPARATION OF BASE	SQ YD	46,073		
15	MIXTURE FOR CRACKS, JOINTS, AND FLANGEWAYS	TON	21		
16	CLASS B PATCHES 6", TYPE II	SQ YD	3,287		
17	CLASS B PATCHES 6", TYPE III	SQ YD	1,061		
18	CLASS B PATCHES 6", TYPE IV	SQ YD	1,618		
19	CLASS D PATCHES 5", TYPE II	SQ YD	13		
20	CLASS D PATCHES 5", TYPE III	SQ YD	75		
21	CLASS D PATCHES 5", TYPE IV	SQ YD	138		
22	PAVEMENT FABRIC	SQ YD	2,613		
23	DOWEL BARS 1"	EACH	8,952		
24	SODDING SPECIAL	SQ YD	1,852		
25	SIDEWALK REMOVAL	SQ FT	2,674		
26	PORTLAND CEMENT CONCRETE SIDEWALK 5"	SQ FT	2,674		
27	DETECTABLE WARNINGS	SQ FT	572		
28	COMBINATION CURB AND GUTTER REMOVAL	FOOT	2,477		
29	COMBINATION CONCRETE CURB AND GUTTER, TYPE B-6.12 (MODIFIED)	FOOT	2,477		
30	TRENCH BACKFILL	CU YD	147		
31	STORM SEWER, PVC SDR 26, 12"	FOOT	165		
32	STRUCTURES TO BE ADJUSTED	EACH	128		
33	VALVE BOX TO BE ADJUSTED	EACH	5		
34	TYPE 1 FRAME AND ADA GRATE	EACH	2		
35	STRUCTURES TO BE RECONSTRUCTED	EACH	5		
36	CATCH BASIN TYPE A, 4' - DIAMETER, TYPE 1 FRAME, OPEN LID	EACH	1		
37	MANHOLES, TYPE A, 4' - DIAMETER, TYPE 1 FRAME CLOSED LID	EACH	1		
38	REMOVING MANHOLES	EACH	1		
39	THERMOPLASTIC PAVEMENT MARKING - L&S	SQ FT	12		
40	THERMOPLASTIC PAVEMENT MARKING - LINE 24"	FOOT	124		
41	EARTH EXCAVATION	CU YD	30		
42	REMOVE AND DISPOSAL OF UNSUITABLE MATERIAL	CU YD	963		
43	POROUS GRANULAR EMBANKMENT	CU YD	963		

NOT FOR BID



NOT FOR BID

RETURN WITH BID

CONTRACTOR CERTIFICATIONS

County	<u>DuPage</u>
Local Public Agency	<u>Village of Villa Park</u>
Section Number	<u>N/A</u>
Route	<u>Various Streets</u>

The certifications hereinafter made by the bidder are each a material representation of fact upon which reliance is placed should the Department enter into the contract with the bidder.

1. **Debt Delinquency.** The bidder or contractor or subcontractor, respectively, certifies that it is not delinquent in the payment of any tax administered by the Department of Revenue unless the individual or other entity is contesting, in accordance with the procedures established by the appropriate revenue Act, its liability for the tax or the amount of tax. Making a false statement voids the contract and allows the Department to recover all amounts paid to the individual or entity under the contract in a civil action.

2. **Bid-Rigging or Bid Rotating.** The bidder or contractor or subcontractor, respectively, certifies that it is not barred from contracting with the Department by reason of a violation of either 720 ILCS 5/33E-3 or 720 ILCS 5/33E-4.

A violation of Section 33E-3 would be represented by a conviction of the crime of bid-rigging which, in addition to Class 3 felony sentencing, provides that any person convicted of this offense or any similar offense of any state or the United States which contains the same elements as this offense shall be barred for 5 years from the date of conviction from contracting with any unit of State or local government. No corporation shall be barred from contracting with any unit of State or local government as a result of a conviction under this Section of any employee or agent of such corporation if the employee so convicted is no longer employed by the corporation and: (1) it has been finally adjudicated not guilty or (2) if it demonstrates to the governmental entity with which it seeks to contract and that entity finds that the commission of the offense was neither authorized, requested, commanded, nor performed by a director, officer or a high managerial agent in behalf of the corporation.

A violation of Section 33E-4 would be represented by a conviction of the crime of bid-rotating which, in addition to Class 2 felony sentencing, provides that any person convicted of this offense or any similar offense of any state or the United States which contains the same elements as this offense shall be permanently barred from contracting with any unit of State or local government. No corporation shall be barred from contracting with any unit of State or local government as a result of a conviction under this Section of any employee or agent of such corporation if the employee so convicted is no longer employed by the corporation and: (1) it has been finally adjudicated not guilty or (2) if it demonstrates to the governmental entity with which it seeks to contract and that entity finds that the commission of the offense was neither authorized, requested, commanded, nor performed by a director, officer or a high managerial agent in behalf of the corporation.

3. **Bribery.** The bidder or contractor or subcontractor, respectively, certifies that it has not been convicted of bribery or attempting to bribe an officer or employee of the State of Illinois or any unit of local government, nor has the firm made an admission of guilt of such conduct which is a matter of record, nor has an official, agent, or employee of the firm committed bribery or attempted bribery on behalf of the firm and pursuant to the direction or authorization of a responsible official of the firm.

4. **Interim Suspension or Suspension.** The bidder or contractor or subcontractor, respectively, certifies that it is not currently under a suspension as defined in Subpart I of Title 44 Subtitle A Chapter III Part 6 of the Illinois Administrative Code. Furthermore, if suspended prior to completion of this work, the contract or contracts executed for the completion of this work may be cancelled.

NOT FOR BID

RETURN WITH BID

SIGNATURES

County DuPage  
Local Public Agency Village of Villa Park  
Section Number N/A  
Route Various Streets

(If an individual)

Signature of Bidder \_\_\_\_\_  
Business Address \_\_\_\_\_  
\_\_\_\_\_

(If a partnership)

Firm Name \_\_\_\_\_  
Signed By \_\_\_\_\_  
Business Address \_\_\_\_\_  
\_\_\_\_\_

Inset Names and Addressed of All Partners



(If a corporation)

Corporate Name \_\_\_\_\_  
Signed By \_\_\_\_\_  
President  
Business Address \_\_\_\_\_  
\_\_\_\_\_

Inset Names of Officers



President \_\_\_\_\_  
Secretary \_\_\_\_\_  
Treasurer \_\_\_\_\_

Attest: \_\_\_\_\_  
Secretary

NOT FOR BID

# Local Agency Proposal Bid Bond

Route Various Streets  
 County DuPage  
 Local Agency Village of Villa Park  
 Section N/A

**RETURN WITH BID**

### PAPER BID BOND

WE \_\_\_\_\_ as PRINCIPAL,  
 and \_\_\_\_\_ as SURETY,

are held jointly, severally and firmly bound unto the above Local Agency (hereafter referred to as "LA") in the penal sum of 5% of the total bid price, or for the amount specified in the proposal documents in effect on the date of invitation for bids whichever is the lesser sum. We bind ourselves, our heirs, executors, administrators, successors, and assigns, jointly pay to the LA this sum under the conditions of this instrument.

WHEREAS THE CONDITION OF THE FOREGOING OBLIGATION IS SUCH that, the said PRINCIPAL is submitting a written proposal to the LA acting through its awarding authority for the construction of the work designated as the above section.

THEREFORE if the proposal is accepted and a contract awarded to the PRINCIPAL by the LA for the above designated section and the PRINCIPAL shall within fifteen (15) days after award enter into a formal contract, furnish surety guaranteeing the faithful performance of the work, and furnish evidence of the required insurance coverage, all as provided in the "Standard Specifications for Road and Bridge Construction" and applicable Supplemental Specifications, then this obligation shall become void; otherwise it shall remain in full force and effect.

IN THE EVENT the LA determines the PRINCIPAL has failed to enter into a formal contract in compliance with any requirements set forth in the preceding paragraph, then the LA acting through its awarding authority shall immediately be entitled to recover the full penal sum set out above, together with all court costs, all attorney fees, and any other expense of recovery.

IN TESTIMONY WHEREOF, the said PRINCIPAL and the said SURETY have caused this instrument to be signed by their respective officers this \_\_\_\_\_ day of \_\_\_\_\_

#### Principal

\_\_\_\_\_  
 (Company Name) \_\_\_\_\_ (Company Name)

By: \_\_\_\_\_ By: \_\_\_\_\_  
 (Signature and Title) (Signature and Title)

(If PRINCIPLE is a joint venture of two or more contractors, the company names, and authorized signatures of each contractor must be affixed.)

#### Surety

By: \_\_\_\_\_  
 (Name of Surety) (Signature of Attorney-in-Fact)

STATE OF ILLINOIS,  
 COUNTY OF \_\_\_\_\_

I, \_\_\_\_\_, a Notary Public in and for said county,  
 do hereby certify that \_\_\_\_\_

(Insert names of individuals signing on behalf of PRINCIPAL & SURETY)

who are each personally known to me to be the same persons whose names are subscribed to the foregoing instrument on behalf of PRINCIPAL and SURETY, appeared before me this day in person and acknowledged respectively, that they signed and delivered said instruments as their free and voluntary act for the uses and purposes therein set forth.

Given under my hand and notarial seal this \_\_\_\_\_ day of \_\_\_\_\_

My commission expires \_\_\_\_\_  
 (Notary Public)

### ELECTRONIC BID BOND

**Electronic bid bond is allowed (box must be checked by LA if electronic bid bond is allowed)**

The Principal may submit an electronic bid bond, in lieu of completing the above section of the Proposal Bid Bond Form. By providing an electronic bid bond ID code and signing below, the Principal is ensuring the identified electronic bid bond has been executed and the Principal and Surety are firmly bound unto the LA under the conditions of the bid bond as shown above. (If PRINCIPAL is a joint venture of two or more contractors, an electronic bid bond ID code, company/Bidder name title and date must be affixed for each contractor in the venture.)

\_\_\_\_\_  
 Electronic Bid Bond ID Code

\_\_\_\_\_  
 (Company/Bidder Name)

\_\_\_\_\_  
 (Signature and Title)

\_\_\_\_\_  
 Date

NOT FOR BID

# Apprenticeship or Training Program Certification

**Return with Bid**

Route	<u>Various Streets</u>
County	<u>DuPage</u>
Local Agency	<u>Village of Villa Park</u>
Section	<u>N/A</u>

**All contractors are required to complete the following certification:**

- For this contract proposal or for all groups in this deliver and install proposal.
- For the following deliver and install groups in this material proposal:

---



---



---

Illinois Department of Transportation policy, adopted in accordance with the provisions of the Illinois Highway Code, requires this contract to be awarded to the lowest responsive and responsible bidder. The award decision is subject to approval by the Department. In addition to all other responsibility factors, this contract or deliver and install proposal requires all bidders and all bidders' subcontractors to disclose participation in apprenticeship or training programs that are (1) approved by and registered with the United States Department of Labor's Bureau of Apprenticeship and Training, and (2) applicable to the work of the above indicated proposals or groups. Therefore, all bidders are required to complete the following certification:

- I. Except as provided in paragraph IV below, the undersigned bidder certifies that it is a participant, either as an individual or as part of a group program, in an approved apprenticeship or training program applicable to each type of work or craft that the bidder will perform with its own employees.
- II. The undersigned bidder further certifies for work to be performed by subcontract that each of its subcontractors submitted for approval either (A) is, at the time of such bid, participating in an approved, applicable apprenticeship or training program; or (B) will, prior to commencement of performance of work pursuant to this contract, establish participation in an approved apprenticeship or training program applicable to the work of the subcontract.
- III. The undersigned bidder, by inclusion in the list in the space below, certifies the official name of each program sponsor holding the Certificate of Registration for all of the types of work or crafts in which the bidder is a participant and that will be performed with the bidder's employees. Types of work or craft that will be subcontracted shall be included and listed as subcontract work. The list shall also indicate any type of work or craft job category for which there is no applicable apprenticeship or training program available.

---



---



---



---

NOT FOR BID

IV. Except for any work identified above, any bidder or subcontractor that shall perform all or part of the work of the contract or deliver and install proposal solely by individual owners, partners or members and not by employees to whom the payment of prevailing rates of wages would be required, check the following box, and identify the owner/operator workforce and positions of ownership.

---

---

---

---

The requirements of this certification and disclosure are a material part of the contract, and the contractor shall require this certification provision to be included in all approved subcontracts. The bidder is responsible for making a complete report and shall make certain that each type of work or craft job category that will be utilized on the project is accounted for and listed. The Department at any time before or after award may require the production of a copy of each applicable Certificate of Registration issued by the United States Department of Labor evidencing such participation by the contractor and any or all of its subcontractors. In order to fulfill the participation requirement, it shall not be necessary that any applicable program sponsor be currently taking or that it will take applications for apprenticeship, training or employment during the performance of the work of this contract or deliver and install proposal.

Bidder: \_\_\_\_\_

By: \_\_\_\_\_

(Signature)

Address: \_\_\_\_\_

Title: \_\_\_\_\_

NOT FOR BIDDING

NOT FOR BID

RETURN WITH BID

Affidavit of Illinois Business Office

County DuPage  
Local Public Agency Village of Villa Park  
Section Number N/A  
Route Various Streets

State of \_\_\_\_\_ )  
County of \_\_\_\_\_ ) ss.

I, \_\_\_\_\_ of \_\_\_\_\_, \_\_\_\_\_,  
(Name of Affiant) (City of Affiant) (State of Affiant)

being first duly sworn upon oath, states as follows:

1. That I am the \_\_\_\_\_ of \_\_\_\_\_ bidder.  
officer or position
2. That I have personal knowledge of the facts herein stated.
3. That, if selected under this proposal, \_\_\_\_\_, will maintain a  
(bidder)  
business office in the State of Illinois which will be located in \_\_\_\_\_ County, Illinois.
4. That this business office will serve as the primary place of employment for any persons employed in the construction contemplated by this proposal.
5. That this Affidavit is given as a requirement of state law as provided in Section 30-22(8) of the Illinois Procurement Code.

\_\_\_\_\_  
(Signature)

\_\_\_\_\_  
(Print Name of Affiant)

This instrument was acknowledged before me on \_\_\_\_\_ day of \_\_\_\_\_, \_\_\_\_\_.

(SEAL)

\_\_\_\_\_  
(Signature of Notary Public)

NOT FOR BID

## Affidavit of Availability For the Letting of \_\_\_\_\_

**Instructions:** Complete this form by either typing or using black ink. "Authorization to Bid" will not be issued unless both sides of this form are completed in detail. Use additional forms as needed to list all work.

### Part I. Work Under Contract

List below all work you have under contract as either a prime contractor or a subcontractor. It is required to include all pending low bids not yet awarded or rejected. In a joint venture, list only that portion of the work which is the responsibility of your company. The uncompleted dollar value is to be based upon the most recent engineer's or owners estimate, and must include work subcontracted to others. If no work is contracted, show **NONE**.

	1	2	3	4	Awards Pending	
Contract Number						
Contract With						
Estimated Completion Date						
Total Contract Price						Accumulated Totals
Uncompleted Dollar Value if Firm is the Prime Contractor						
Uncompleted Dollar Value if Firm is the Subcontractor						
<b>Total Value of All Work</b>						

### Part II. Awards Pending and Uncompleted Work to be done with your own forces.

List below the uncompleted dollar value of work for each contract and awards pending to be completed with your own forces. All work subcontracted to others will be listed on the reverse of this form. In a joint venture, list only that portion of the work to be done by your company. If no work is contracted, show **NONE**.

							Accumulated Totals
Earthwork							
Portland Cement Concrete Paving							
HMA Plant Mix							
HMA Paving							
Clean & Seal Cracks/Joints							
Aggregate Bases & Surfaces							
Highway, R.R. and Waterway Structures							
Drainage							
Electrical							
Cover and Seal Coats							
Concrete Construction							
Landscaping							
Fencing							
Guardrail							
Painting							
Signing							
Cold Milling, Planning & Rotomilling							
Demolition							
Pavement Markings (Paint)							
Other Construction (List)							
							\$ 0.00
<b>Totals</b>							

Disclosure of this information is **REQUIRED** to accomplish the statutory purpose as outlined in the "Illinois Procurement Code." Failure to comply will result in non-issuance of an "Authorization To Bid." This form has been approved by the State Forms Management Center.

NOT FOR BID

**Part III. Work Subcontracted to Others.**

For each contract described in Part I, list all the work you have subcontracted to others.

	1	2	3	4	Awards Pending
Subcontractor					
Type of Work					
Subcontract Price					
Amount Uncompleted					
Subcontractor					
Type of Work					
Subcontract Price					
Amount Uncompleted					
Subcontractor					
Type of Work					
Subcontract Price					
Amount Uncompleted					
Subcontractor					
Type of Work					
Subcontract Price					
Amount Uncompleted					
Subcontractor					
Type of Work					
Subcontract Price					
Amount Uncompleted					
Subcontractor					
Type of Work					
Subcontract Price					
Amount Uncompleted					
Total Uncompleted					

I, being duly sworn, do hereby declare that this affidavit is a true and correct statement relating to ALL uncompleted contracts of the undersigned for Federal, State, County, City and private work, including ALL subcontract work, ALL pending low bids not yet awarded or rejected and ALL estimated completion dates.

Subscribed and sworn to before me  
 this \_\_\_\_\_ day of \_\_\_\_\_, \_\_\_\_\_ Type or Print Name \_\_\_\_\_  
 \_\_\_\_\_ Officer or Director \_\_\_\_\_ Title

Signed \_\_\_\_\_

\_\_\_\_\_  
 Notary Public

My commission expires \_\_\_\_\_

(Notary Seal)

Company \_\_\_\_\_

Address \_\_\_\_\_

NOT FOR BID

**Local Public Agency  
Formal Contract**

PROPOSAL SUBMITTED BY		
Contractor's Name		
Street	P.O. Box	
City	State	Zip Code

STATE OF ILLINOIS  
 COUNTY DuPage  
Village of Villa Park  
(Name of City, Village, Town or Road District)

FOR THE IMPROVEMENT OF  
 STREET NAME OR ROUTE Various Streets  
 SECTION NO. N/A  
 TYPES OF FUNDS Local

SPECIFICATIONS (required)

PLANS (required)

CONTRACT BOND (when required)

**For Municipal Projects**  
 Submitted/Approved/Passed

Mayor  President of Board of Trustees  Municipal Official

\_\_\_\_\_

Date

**Department of Transportation**

Concurrence in approval of award

\_\_\_\_\_

Regional Engineer

\_\_\_\_\_

Date

**For County and Road District Projects**  
 Submitted/Approved

\_\_\_\_\_

Highway Commissioner

\_\_\_\_\_

Date

Submitted/Approved

\_\_\_\_\_

County Engineer/Superintendent of Highways

\_\_\_\_\_

Date

NOT FOR BID

County DuPage  
Local Public Agency Villa Park  
Section Number N/A  
Route Various Streets

1. THIS AGREEMENT, made and concluded the \_\_\_\_\_ day of \_\_\_\_\_, \_\_\_\_\_, \_\_\_\_\_  
Month and Year  
between the President of the Village of Villa Park  
acting by and through its Board of Trustees known as the party of the first part, and  
\_\_\_\_\_ his/their executors, administrators, successors or assigns,  
known as the party of the second part.

2. Witnesseth: That for and in consideration of the payments and agreements mentioned in the Proposal hereto attached, to be made and performed by the party of the first part, and according to the terms expressed in the Bond referring to these presents, the party of the second part agrees with said party of the first part at his/their own proper cost and expense to do all the work, furnish all materials and all labor necessary to complete the work in accordance with the plans and specifications hereinafter described, and in full compliance with all of the terms of this agreement and the requirements of the Engineer under it.

3. And it is also understood and agreed that the LPA Formal Contract Proposal, Special Provisions, Affidavit of Illinois Business Office, Apprenticeship or Training Program Certification, and Contract Bond hereto attached, and the Plans for Route Various Streets, in the Village of Villa Park, approved by the Village of Villa Park on June 5, 2015, are essential documents of this  
Date  
contract and are a part hereof.

4. IN WITNESS WHEREOF, The said parties have executed these presents on the date above mentioned.

Attest: \_\_\_\_\_ The Village of Villa Park  
Clerk By \_\_\_\_\_  
Party of the First Part

(Seal) \_\_\_\_\_  
*(If a Corporation)*  
Corporate Name \_\_\_\_\_

By \_\_\_\_\_  
President Party of the Second Part

*(If a Co-Partnership)*

Attest: \_\_\_\_\_  
Secretary

Partners doing Business under the firm name of

\_\_\_\_\_  
Party of the Second Part

*(If an individual)*

NOT FOR BID

NOT FOR BID

NOT FOR BID

**Contract Bond**

Route Various Streets  
County DuPage  
Local Agency Villa Park  
Section N/A

We , \_\_\_\_\_

a/an)  Individual  Co-partnership  Corporation organized under the laws of the State of \_\_\_\_\_ ,  
as PRINCIPAL, and \_\_\_\_\_

\_\_\_\_\_ as SURETY,

are held and firmly bound unto the above Local Agency (hereafter referred to as "LA") in the penal sum of \_\_\_\_\_

\_\_\_\_\_ Dollars ( \_\_\_\_\_ ), lawful money of the  
United States, well and truly to be paid unto said LA, for the payment of which we bind ourselves, our heirs, executors,  
administrators, successors, jointly to pay to the LA this sum under the conditions of this instrument.

WHEREAS THE CONDITION OF THE FOREGOING OBLIGATION IS SUCH that, the said Principal has entered into a written contract with the LA acting through its awarding authority for the construction of work on the above section, which contract is hereby referred to and made a part hereof, as if written herein at length, and whereby the said Principal has promised and agreed to perform said work in accordance with the terms of said contract, and has promised to pay all sums of money due for any labor, materials, apparatus, fixtures or machinery furnished to such Principal for the purpose of performing such work and has further agreed to pay all direct and indirect damages to any person, firm, company or corporation suffered or sustained on account of the performance of such work during the time thereof and until such work is completed and accepted; and has further agreed that this bond shall inure to the benefit of any person, firm, company or corporation to whom any money may be due from the Principal, subcontractor or otherwise for any such labor, materials, apparatus, fixtures or machinery so furnished and that suit may be maintained on such bond by any such person, firm, company or corporation for the recovery of any such money.

NOW THEREFORE, if the said Principal shall well and truly perform said work in accordance with the terms of said contract, and shall pay all sums of money due or to become due for any labor, materials, apparatus, fixtures or machinery furnished to him for the purpose of constructing such work, and shall commence and complete the work within the time prescribed in said contract, and shall pay and discharge all damages, direct and indirect, that may be suffered or sustained on account of such work during the time of the performance thereof and until the said work shall have been accepted, and shall hold the LA and its awarding authority harmless on account of any such damages and shall in all respects fully and faithfully comply with all the provisions, conditions and requirements of said contract, then this obligation to be void; otherwise to remain in full force and effect.

NOT FOR BID

IN TESTIMONY WHEREOF, the said PRINCIPAL and the said SURETY have caused this instrument to be signed by their respective officers this \_\_\_\_\_ day of \_\_\_\_\_ A.D. \_\_\_\_\_

**PRINCIPAL**

\_\_\_\_\_  
(Company Name)

\_\_\_\_\_  
(Company Name)

By: \_\_\_\_\_  
(Signature & Title)

By: \_\_\_\_\_  
(Signature & Title)

Attest: \_\_\_\_\_  
(Signature & Title)

Attest: \_\_\_\_\_  
(Signature & Title)

(If PRINCIPAL is a joint venture of two or more contractors, the company names and authorized signature of each contractor must be affixed.)

STATE OF ILLINOIS,

COUNTY OF \_\_\_\_\_

I, \_\_\_\_\_, a Notary Public in and for said county, do hereby certify that

\_\_\_\_\_  
(Insert names of individuals signing on behalf or PRINCIPAL)

who are each personally known to me to be the same persons whose names are subscribed to the foregoing instrument on behalf of PRINCIPAL, appeared before me this day in person and acknowledged respectively, that they signed and delivered said instrument as their free and voluntary act for the uses and purposes therein set forth.

Given under my hand and notarial seal this \_\_\_\_\_ day of \_\_\_\_\_ A.D. \_\_\_\_\_

My commission expires \_\_\_\_\_

\_\_\_\_\_  
Notary Public

**(SEAL)**

**SURETY**

\_\_\_\_\_  
(Name of Surety)

By: \_\_\_\_\_  
(Signature of Attorney-in-Fact)

STATE OF ILLINOIS.

COUNTY OF \_\_\_\_\_

I, \_\_\_\_\_, a Notary Public in and for said county, do hereby certify that

\_\_\_\_\_  
(Insert names of individuals signing on behalf or SURETY)

who are each personally known to me to be the same persons whose names are subscribed to the foregoing instrument on behalf of SURETY, appeared before me this day in person and acknowledged respectively, that they signed and delivered said instrument as their free and voluntary act for the uses and purposes therein set forth.

Given under my hand and notarial seal this \_\_\_\_\_ day of \_\_\_\_\_ A.D. \_\_\_\_\_

My commission expires \_\_\_\_\_

\_\_\_\_\_  
Notary Public

**(SEAL)**

Approved this \_\_\_\_\_ day of \_\_\_\_\_, A.D. \_\_\_\_\_

Attest: \_\_\_\_\_

\_\_\_\_\_  
(Awarding Authority)

\_\_\_\_\_  
Clerk

\_\_\_\_\_  
(Chairman/Mayor/President)

NOT FOR BID

## SPECIAL PROVISIONS

The following Special Provisions supplement the “Standard Specifications for Road and Bridge Construction”, adopted January 1, 2012 (referred to hereinafter as the Standard Specifications); the “Supplemental Specifications and Recurring Special Provisions”, adopted January 1, 2014; the latest edition of the “Illinois Manual on Uniform Traffic Control Devices For Streets and Highways” (IMUTCD); and the “Standard Specifications for Water and Sewer Construction in Illinois”, July 2009, Sixth Edition (referred to hereinafter as the Water and Sewer Specifications). In case of conflict with any part, or parts, of said Specifications, the said Special Provisions shall take precedence and shall govern. Where no conflict exists, the said Specifications shall apply to this Contract as if repeated in their entirety herein.

### LOCATION OF PROJECT

This contract shall consist of general maintenance work throughout the Village of Villa Park. Following is the list of locations where this work shall occur:

Biermann Ave.	From	Terrace St.	To	Sunset Dr.
2 <sup>nd</sup> Ave.	From	Terrace St.	To	Stone Rd.
3 <sup>rd</sup> Ave.	From	Terrace St.	To	Stone Rd.
Cornell St.	From	St. Charles Rd.	To	Metra Parking Lot
Division St.	From	Harvard Ave.	To	Ardmore Ave.
Terrace St.	From	Yale Ave.	To	Ardmore Ave.
Ridge Rd.	From	Biermann Ave	To	Addison Rd.
Illinois Ave	From	Division St.	To	Metra Parking Lot
Home Alley	From	Harvard Ave.	To	Ardmore Ave
Yale Ave	From	Home Alley	To	St. Charles Rd.

### DESCRIPTION OF PROJECT

This project is a general maintenance project and the work to be performed under this contract includes, but is not limited to HMA asphalt surface removal, PCC Surface Removal, resurfacing with leveling binder and HMA surface courses, combination curb and gutter removal and replacement, pavement patching, drainage structure adjustments, and all incidental and collateral work necessary to complete the project as described herein.

The location of the work to be performed shall be as marked in the field by the Resident Engineer. The exact locations of hot-mix asphalt surface removal, PCC surface removal, pavement patching, and combination curb and gutter removal and replacement shall be provided during construction by the Resident Engineer)

## DEFINITIONS

**Contractor.** The individual, firm, partnership, joint venture, or corporation contracting with the Village of Villa Park for performance of prescribed work.

**Department, Owner or Village.** The Village of Villa Park, DuPage County, Illinois.

**Engineer.** The Resident Engineer who is the authorized representative of the Village of Villa Park in immediate charge of the engineering details of a construction project.

## QUALIFICATIONS OF BIDDERS

Bidders will comply with all applicable Federal, State and local laws and requirements, and will further meet the qualifications prescribed in this and other applicable portions of these provisions.

Bidder, in submitting a Bid, certifies that Bidder is in compliance with all applicable Federal, State and local laws and requirements, and that Bidder further meets the qualifications prescribed in this and other applicable portions of these provisions. Engineer's determination as to the compliance and qualifications of the Bidder will be final, and Bidder, in submitting a Bid, agrees to be bound by that determination.

Bidder, in submitting a Bid, certifies that Bidder is in compliance with the following requirements and qualifications. Bidder further certifies that Bidder is able to provide written evidence of Bidder's compliance with the following requirements and qualifications. Bidder shall, upon request by Engineer, submit such written evidence within five (5) calendar days of the Engineer's request, as well as any other written evidence which Engineer may deem necessary for the purpose of evaluating Bidder's qualifications.

- (a) Bidder shall be qualified to do business in the State of Illinois.
- (b) Bidder shall possess either a valid Federal Employer Tax Identification Number (FEIN) or a valid Social Security Number (SSN).
- (c) Bidder shall be able to provide a street address and description of the Bidder's place of business, and the mailing address of the business, if different from the street address.

- (d) Bidder shall be able to provide the number of years Bidder has been engaged in the contracting business under the present firm name, and the name of the state where incorporated.
- (e) Bidder shall be able to provide a list of the property and equipment available to the Bidder.
- (f) Bidder shall be able to provide a financial statement demonstrating that the Bidder has the financial resources to meet all obligations related to the Work.
- (g) Bidder shall maintain insurance policies with the coverages required by the Contract, and with the minimum limits of coverage required by the Contract. Bidder shall be able to provide current certificate(s) of insurance for the insurance policies held by Bidder, demonstrating that Bidder holds insurance policies with the coverages required by the contract, and with the minimum limits of coverage required by the Contract.
- (h) Bidder shall have constructed a minimum of three (3) projects of a similar nature in the immediate past five (5) years. Bidder shall be able to provide a list of all projects of a similar nature constructed by Bidder in the immediate past five (5) years, which list shall contain the minimum of three (3) such projects, which list shall provide a description and the location(s) of all such projects, and shall contain the Bidder's performance record and references, as well as the names and current contact information, including addresses and telephone numbers, of persons who acted as owners' representatives for those projects and who have knowledge of those projects, and whom Bidder agrees the Village may contact for the purpose of verifying Bidder's performance and references.
- (i) Bidder shall be able to provide a list of three (3) references (name, address and telephone number) with knowledge of the integrity and business practices of the bidder. Such references may not be persons who have been employed by Bidder as employees.
- (j) Bidder shall be able to provide a list of projects presently under Contract, the awarded Contract amount of each, the approximate adjusted Contract amount of each (if applicable), and the dollar amount or percent of completion of each.
- (k) Bidder shall be able to provide a list of Contracts which have resulted in lawsuits, whether against Bidder as a prime contractor, against Bidder as a subcontractor, or against Bidder as a party in any other capacity; or against subcontractors or suppliers performing work for Bidder or under Contract held by Bidder.
- (l) Bidder shall be able to provide a list of Contracts defaulted.

- (m) Bidder shall be able to provide a statement indicating whether or not Bidder has ever filed bankruptcy.
- (n) Bidder shall be able to provide a list of all officers of the firm, which list shall also indicate those officers who, while in the employ of the firm or in the employ of previous firms, were associated with Contracts which resulted in lawsuits, Contracts defaulted, or firms which filed for bankruptcy.
- (o) Bidder shall maintain personnel guaranteed to be employed in the responsible charge of the Work, which personnel possess sufficient technical experience to ensure the satisfactory completion of the Work. Bidder shall be able to provide the names and technical experience of such personnel, as well as statements as to whether the personnel have or have not performed satisfactorily on other contracts of like nature and magnitude or comparable difficulty at similar rate of progress.
- (p) Bidder shall be able to provide a list of subcontractors and suppliers anticipated to be employed by Bidder for the purpose of completing the Work, including the firm name, street address and description of place of business; mailing address of business (if different); phone, fax and e-mail contact information of business; name of primary contact; and a list of any projects or contracts for which Bidder currently owes monies to said firm, which list shall include a description of the project or contract, the amount currently due to said firm, the period of time for which those monies have been owed, and the expected date of payment of those monies.
- (q) Bidder shall participate in active apprenticeship and training programs approved by and registered with the United States Department of Labor Bureau of Apprenticeship and Training for each of the trades of work contemplated under the Contract. Bidder shall be able to provide evidence of Bidder's participation in such apprenticeship and training programs.
- (r) Bidder shall only employ subcontractors who meet the requirements prescribed in this section and other sections of these specifications.
- (s) Bidder shall be able to provide such other information as may assist the Village in determining whether the Bidder is adequately prepared to fulfill the Contract.

These requirements and qualifications are not intended to discourage bidding, to make it difficult for qualified Bidders to submit Bids, or to discourage beginning contractors. The purpose of these requirements and qualifications is to allow the Village to obtain sufficient information about Bidder's financial state, available equipment, personnel, and previous work experience so that the Village may mitigate the hazards involved in awarding contracts to parties who may not be qualified to perform the Work as specified.

## **INCREASED OR DECREASED QUANTITIES**

The Village reserves the right to increase or decrease the amount of work shown in the plans in accordance with Section 109 of the Standard Specifications.

## **SUBCONTRACTING**

Add the following to the end of Section 108.01 of the Standard Specifications:

“The apparent low Bidder will submit to the Engineer within ten calendar days after the receipt of bids, a list of the names of Bidder’s proposed subcontractors along with a description of the work to be performed by each.”

## **WORKING HOURS**

Working hours will be between 7:00 A.M. and 5:00 P.M., Monday through Friday, excluding legal holidays as designated by the Contract.

Contractor will not permit the performance of Work outside these working hours without Owner’s written consent, which may be given after prior written request to Engineer, except as otherwise required for the safety of persons or the Work or property at the Site or adjacent thereto, and except as otherwise stated in the Contract Documents.

If Contractor permits the performance of Work outside these working hours, Contractor will compensate Owner for the costs of inspection and other services provided by Engineer. Owner will determine the rates at which such inspection and other services are to be compensated. Owner will determine the interval or intervals at which billing will take place, and may, at Owner’s discretion, submit invoices for payment to Contractor, or deduct the costs from any monies due or to become due to the Contractor from Owner.

## **HOLIDAYS**

Add the following to the list of legal holidays in Article 107.09 of the Standard Specifications:

Thanksgiving Friday  
Christmas Eve  
New Year’s Eve

## **INSURANCE**

Insurance and indemnification shall be according to applicable sections of the Standard Specifications, and shall also be according to the "IRMA Contractual Insurance Guidelines", incorporated herein as Appendix A. If a conflict is determined to exist between the requirements prescribed in the Standard Specifications and the requirements prescribed in the IRMA Contractual Insurance Guidelines, such conflict will be resolved as follows:

- a. If a particular type of insurance coverage is required by one standard but not by both, that type of insurance coverage will be required.
- b. If the minimum limits of insurance coverage required by one standard differ from those required by the other standard, the higher minimum limits of insurance coverage will prevail.
- c. If any other conflicts are determined to exist between the requirements prescribed in the two standards, the stricter of the two requirements will prevail. Owner will make the final determination as to what constitutes a stricter requirement.

## **MAINTENANCE OF ROADWAYS**

Effective: September 30, 1985

Revised: November 1, 1996

Beginning on the date that work begins on this project, the Contractor shall assume responsibility for normal maintenance of all existing roadways within the limits of the improvement. This normal maintenance shall include all repair work deemed necessary by the Engineer, but shall not include snow removal operations. Traffic control and protection for maintenance of roadways will be provided by the Contractor as required by the Engineer.

If items of work have not been provided in the contract, or otherwise specified for payment, such items, including the accompanying traffic control and protection required by the Engineer, will be paid for in accordance with Article 109.04 of the "Standard Specifications".

## **MOBILIZATION**

Mobilization will be according to Section 671 of the Standard Specifications except as modified herein.

Revise Article 671.02, Basis of Payment, to read:

**“671.02 Basis of Payment.** Mobilization will not be paid for separately but rather shall be included in the cost of the items for which this work applies.”

## **MAINTENANCE GUARANTEE**

The Contractor shall execute and deliver to the Village of Villa Park, before final payment will be issued, a written warranty, in a form satisfactory to the Village, which guarantees that the work is in accordance with the Contract Documents and will not be defective. This warranty shall guarantee this work for a period of one (1)-year from the date of acceptance of the work and final payment by the Village of Villa Park.

If within this guarantee period, any work is found to be defective, as determined by the Village, the Contractor shall promptly and without cost to the Village of Villa Park, correct or repair such defective work, or remove and replace the defective work in accordance with the Special Provisions for the items in question.

The Contractor shall furnish a warranty bond in an amount equal to fifty percent (50%) of the contract amount by a surety satisfactory to the Village to guarantee Contractor's warranty to repair defective work.

## **USE OF FIRE HYDRANTS**

Effective: August 27, 2013  
Revised: February 7, 2014

Revise Article 107.18 of the Standard Specifications to read:

**“107.18 Use of Fire Hydrants.** If Contractor requires water for the completion of construction operations, and desires to obtain water from Owner, Contractor shall make application to Engineer accordingly. If such application is approved by Engineer, Contractor shall obtain water from the fire hydrant located at 100 West Home Avenue, adjacent to the Village of Villa Park Fleet Maintenance Garage. Contractor's use of said hydrant and methods of obtaining water shall be in compliance with all applicable local ordinances, rules, and regulations concerning such use. Contractor shall furnish all labor and equipment necessary to make a connection to said hydrant, and to obtain and transport water. Contractor, in obtaining water from said hydrant, shall either:

- (a) Make application to Engineer for temporary use of a hydrant meter, comply with all conditions requisite for use of said meter if such application is approved, and use said hydrant meter when obtaining water from hydrant; or
- (b) Make record of the quantity of water obtained from said hydrant along with the date and time obtained, and report such information after each use to the Village of Villa Park Public Works Department, 11 West Home Avenue, or, if

such use takes place outside of the normal working hours of the Public Works Department, report such information after the next use which takes place during normal working hours.

Contractor shall not use, operate or obtain water from any hydrants other than the one prescribed. Contractor shall not obtain water from Owner for construction operations or activities not under contract with Owner.

Contractor shall compensate Owner for water obtained by Contractor at the current rate charged to commercial customers by Owner, which rate may also include any administrative fees, overhead, or other costs which are typically charged to commercial customers. The actual quantity of water obtained by Contractor may, at Owner's discretion, be rounded up to the next 1,000 gallon increment so as to coincide with standard units of measure on which water billing rates are based. Owner will determine the interval or intervals at which billing will take place, and may, at Owner's discretion, submit invoices for payment to Contractor, or deduct the cost of water from any monies due or to become due to the Contractor from Owner."

## **PROTECTION OF EXISTING DRAINAGE FACILITIES DURING CONSTRUCTION**

Unless otherwise noted in the contract plans, the existing drainage facilities shall remain in use during the period of construction.

Locations of existing drainage structures and sewers, if shown on the contract plans, are approximate. Prior to commencement of work, the Contractor, at his/her own expense, shall determine the exact location of existing structures which are within the proposed construction site.

All drainage structures are to be kept free from any debris resulting from construction operations. All work and materials necessary to prevent accumulation of debris in the drainage structure resulting from construction operations shall be removed at the Contractor's own expense, and no extra compensation will be allowed.

Unless reconstruction or adjustment of an existing manhole, catch basin, or inlet is called for in the contract plans or ordered by the Engineer, the proposed work shall meet the existing elevations of these structures. Should reconstruction or adjustment of a drainage structure be required by the Engineer in the field, the necessary work and payment shall be done in accordance with Section 602 and Article 104.02 respectively, of the Standard Specifications.

Existing frames and grates are to remain unless otherwise noted in the contract plans or as directed by the Engineer. Frames and grates that are missing or damaged prior to construction shall be replaced. The type of replacements frame or grate shall be determined by the Engineer, and replacement and payment for same shall be in

accordance with Section 604 and Article 104.02 respectively, of the Standard Specifications unless otherwise noted in the plans or special provisions.

## **CONSTRUCTION SAFETY AND HEALTH STANDARDS**

It is a condition of this contract and shall be made a condition of each subcontract entered into pursuant to this contract that the Contractor and any Subcontractor shall not require any laborer or mechanic employed in performance of the contract to work in surroundings or under working conditions which are unsanitary, hazardous or dangerous to their health or safety, as determined under Federal Construction Safety and Health Standards.

## **KEEPING ROADS OPEN TO TRAFFIC**

All roads shall remain open to traffic unless otherwise shown on the contract plans. When necessary to close one lane because of construction, the Contractor shall maintain one-way traffic during construction hours with the use of signs and flaggers as shown on the Traffic Control Standards. Two lanes of traffic will be maintained during nights and weekends when no construction activities are being carried on.

## **RESPONSIBILITY FOR VANDALISM**

The contractor shall be responsible for the defacement of any concrete pours before they have set up. Concrete pavement, sidewalk, driveway, or curbing that has been defaced, in the opinion of the Engineer, shall be removed and replaced by the contractor at his expense.

## **BITUMINOUS MATERIALS (PRIME COAT)**

**Description.** This work shall be performed in accordance with Section 406 of the Standard Specifications, with the following modifications:

Bituminous prime coat shall be placed at least one hour in advance of the placement of HMA, but no more than forty-eight hours in advance of the placement of HMA. If Contractor places prime coat more than forty-eight hours in advance of the placement of HMA, the prime coat will not be measured for payment, and Contractor will place prime coat again in accordance with this provision. Prime coat will not be placed on weekends or on legal holidays unless permitted by the Engineer. Prime coat will not be placed before weekends or legal holidays when placement of HMA is not expected to take place until after the weekend or legal holiday, unless permitted by the Engineer.

**Basis of Payment.** This work will be paid for at the contract unit price per pound for BITUMINOUS MATERIALS (PRIME COAT); which price shall include all labor, materials, and equipment necessary to complete the work as described herein.

## **CONTINGENCY ALLOWANCE**

A contingency allowance pay item is provided as a part of this contract for the purpose of facilitating the completion of unforeseen or additional work not included in the contract as awarded, and which is determined by the Engineer to be necessary and germane to the contract.

Use of the contingency allowance will be at the discretion of the Engineer. The Engineer may, at his/her discretion, use the contingency allowance for any of the following reasons:

- (a) Facilitate a temporary payment allowance to the Contractor for work completed under existing contract pay items and for which completed quantities exceed contract quantities;
- (b) Facilitate a temporary payment allowance to the Contractor for work completed beyond the scope of existing contract pay items; or
- (c) Facilitate a temporary payment allowance to the Contractor for the purchase of equipment, materials or such other requisition as Engineer determines to be necessary for the completion of the Work.

Such use of the CONTINGENCY ALLOWANCE will be further subject to approval by Owner. Owner's decision with regard to use of the CONTINGENCY ALLOWANCE will be final.

- A. Any payments made to Contractor under the CONTINGENCY ALLOWANCE will be considered temporary, and will only be retained by Contractor until such time that an authorization of contract changes can be approved and incorporated into the contract.
- B. Contractor, in accepting payments made under the CONTINGENCY ALLOWANCE, agrees to the terms of this and other applicable special provisions. Contractor agrees to relinquish any monies and any claim to monies paid under the CONTINGENCY ALLOWANCE upon approval of an authorization of contract changes and payment for any work for which payment was previously made under the CONTINGENCY ALLOWANCE. Contractor further agrees to return any monies previously paid thereunder.
- C. The CONTINGENCY ALLOWANCE pay item for this contract has been established with a unit of measurement in dollars, a quantity of 50,000.00,

and a contract unit price of one dollar (\$1.00), for a total CONTINGENCY ALLOWANCE contract price of Fifty Thousand dollars and no cents (\$50,000.00). Bidder, in submitting a bid, accepts the quantity, unit price, and total contract price of the CONTINGENCY ALLOWANCE.

Basis of Payment. This work will be paid for at the contract unit price per dollar for CONTINGENCY ALLOWANCE. The total bid amount for this item will be \$50,000.00.

## **PRECONSTRUCTION VIDEO RECORDING**

Description. This work consists of performing color video and audio recording of the project area and other areas which may be impacted by construction.

Preconstruction video recordings will include coverage of the project area and all other areas which may be impacted by construction. Video recordings will also include construction easements when applicable. Video recordings will provide a visual record of all physical features within those areas, including, but not limited to, roadways, pavements, curbs, gutters, driveways, driveway aprons, sidewalks, carriage walks, parkways, trees, landscaping, shrubbery, plantings, landscaping walls, retaining walls, signs, sign posts, fences, utility poles, light poles, utilities, equipment, manholes, b-boxes, cleanouts, valves, curb structures, pipelines, buildings, mailboxes, and any other features located within the project area.

Video recordings will begin with an audio narrative which provides the current date and time, the name of Owner and name of project, and a description of both the starting location and the location or locations to be recorded, including street name or names, street addresses, and any additional information which may be necessary to describe the location and subject of viewing.

Video recordings will maintain viewer orientation by means of an audio commentary in the audio track of each video recording which provides an explanation of what is being viewed; and by videotaping landmarks and readily identifiable objects (property addresses, street signs, etc.) at appropriate intervals.

Preconstruction video recordings will be recorded at a rate of travel not exceeding 48 feet per minute, and zooming and panning rates will be controlled to provide clarity of features during playback. The finished product will be provided with bright, clear pictures and accurate colors free from distortion, tearing, rolls, or other forms of picture imperfection. The audio will have proper volume and clarity. All recordings will be performed at times of satisfactory visibility, and when no more than ten percent of ground is obscured by snow, leaves, or other cover.

If any element within or portion of the project area is not adequately documented by the preconstruction video recording so as to definitively demonstrate its condition prior to the start of construction, Contractor will assume responsibility for the repair, restoration

or replacement of that element or portion of the project area. Such repair, restoration or replacement will be to equal or better condition than previously existing, and will further comply with all standards and provisions which govern the work in question.

Schedule. Preconstruction video recording will be performed according to the following schedule:

- (a) Preconstruction video recording will take place after a Notice to Proceed has been issued.
- (b) Preconstruction video recording will take place after the Joint Utility Locating Information for Excavators (JULIE) request for the project area has cleared.
- (c) Preconstruction video recording will take place before any equipment, materials, or other items are delivered to the site.
- (d) Preconstruction video recording will take place no more than seven (7) chargeable days prior to the start of construction.
- (e) Preconstruction video recording will take place, the required pre-construction video recording deliverables will be submitted to the Engineer, and the Engineer will review and issue written approval of the video before any activity other than utility locating will be permitted to start. Such activity will include, but not be limited to, delivery of materials and equipment, installation of traffic control and erosion control, and completion of construction layout and tree protection. No days will be charged against the contract time while the video is under review by the Engineer, including the day the deliverables are submitted and the day a response is provided. If the video or any portions thereof are rejected, the contract time will commence to run until revisions are submitted.
- (f) The recording will be submitted to Engineer for review prior to commencement of any construction, and receive acceptance of recordings prior to commencement of construction. Any areas found not acceptable to the Owner will be re-filmed at no additional cost to the contract.

Deliverables.

Video will be high-definition, with a minimum resolution of 1280 x 720 pixels per frame. Video will be filmed in a landscape aspect ratio. Video filmed in a portrait aspect ratio will be considered unacceptable and will be rejected.

Preconstruction video recordings will be provided as electronic files of .avi, .mp4, .m4v, .mkv, .wmv, or .mpg file format, or of such other file format as may be approved by Engineer. Preconstruction video recordings will be provided as independent digital

container format files, which container files will include all video, audio, and other electronic information necessary to view the preconstruction video recording as intended.

Video DVD will be considered an unacceptable format for providing preconstruction video recordings, and will be rejected.

Preconstruction video recording electronic files will be provided on a portable electronic media device or devices of one of the following types: USB flash drive, SD flash memory card, CF flash memory card, data DVD, external hard drive, or such other portable electronic media device as may be approved by Engineer. Preconstruction video recording electronic files may also be provided via online file sharing, cloud storage, File Transfer Protocol (FTP), or other online or network file transfer methods if approved by Engineer.

Preconstruction video recording electronic files will be accompanied by corresponding logs which document the dates, times, and locations covered by each preconstruction video recording electronic file.

Contractor shall maintain copies of all items submitted to Engineer for Contractor's own use and record.

Method of Measurement. This work will be measured for payment on a lump sum basis. No measurement will be made of the individual components of this effort.

Basis of Payment. Preconstruction video recording will be paid for at the contract lump sum price for PRECONSTRUCTION VIDEO RECORDING.

NOT FOR BID

VILLAGE OF VILLA PARK, IL  
2015 STREET RESURFACING PROGRAM  
SPECIAL PROVISIONS

MATERIAL INSPECTION – REPORTS

All materials incorporated in this contract are to be inspected according to the Project Procedures Guidelines (PPG) and the process and frequency of testing under the QC/QA specifications.

The Contractor shall be responsible for QC testing of these materials with the Engineer being notified at least forty-eight (48) hours in advance of the placement of any of these materials. The Local Agency shall be responsible for the QA testing of these materials on the job and at the plant per article 1030 of the Standard Specifications. Please note that the Contractor is required to submit a QC plan to the Engineer for approval per the referenced specifications.

All concrete materials incorporated in this contract are to be inspected according to the BDE Special Provision for Quality Control/Quality Assurance of Concrete Mixtures. Please note that the Contractor is required to submit a QC plan to the Engineer for approval per the referenced specifications.

The contractor shall coordinate his work operations with the engineer to assure that the testing agencies can provide proper and sufficient notice to schedule their work. Also, all QC documentation is to be submitted to the Engineer, immediately following completion of this project. Five percent (5%) of the final contract amount due the Contractor will be withheld pending receipt of all documentation and approval of the Engineer's Final Payment Estimate by the District Bureau of Local Roads and Streets.

TRAFFIC CONTROL PLAN

Effective: September 30, 1985

Revised: January 1, 2007

Traffic Control shall be according to the applicable sections of the Standard Specifications, the Supplemental Specifications, the "Illinois Manual on Uniform Traffic Control Devices for Streets and Highways", any special details and Highway Standards contained in the plans, and the Special Provisions contained herein.

Special attention is called to Article 107.09 and Section 701 of the Standard Specifications and the following Highway Standards, Details, Quality Standard for Work Zone Traffic Control Devices, Recurring Special Provisions and Special Provisions contained herein, relating to traffic control.

STANDARDS: 701011-04, 701501-06, 701701-09, 701801-05, 701901-04

DETAILS: TC-10, TC-13

SPECIAL PROVISIONS: Traffic Control Plan

Work Zone Traffic Control shall be paid for at the contract unit price, lump sum for TRAFFIC CONTROL & PROTECTION.

SAW CUT JOINTS

The removal and/or replacement of any driveways, pavement, curb, sidewalk, etc. shall be accomplished by means of a saw cut joint, at the direction of the Engineer. This work will not be paid for separately, but shall be included in the unit price bid for the various items.

HOT-MIX ASPHALT SURFACE REMOVAL, VARIABLE DEPTH

This work shall consist of removing the hot-mix asphalt surface to a depth specified on the plans with a self-propelled milling machine.

The work shall be performed according to Section 440 of the "Standard Specifications" and the depth may vary in order to provide a uniform and constant base profile for the new pavement to be placed on.

This work shall be paid for at the contract unit price per SQUARE YARD for HOT-MIX ASPHALT SURFACE REMOVAL, VARIABLE DEPTH.

PCC SURFACE REMOVAL, VARIABLE DEPTH

This work shall consist of removing the PCC surface to a depth specified on the plans with a self-propelled milling machine. A 2" deep saw cut will be required on either side of the pavement to be ground in order to establish a gutter flag of the existing integral curb.

The work shall be performed according to Section 440 of the "Standard Specifications" and the depth may vary in order to provide a uniform and constant base profile for the new pavement to be placed on.

This work shall be paid for at the contract unit price per SQUARE YARD for HOT-MIX ASPHALT SURFACE REMOVAL, VARIABLE DEPTH. The 2" saw cut will be incidental to the PCC SURFACE REMOVAL VARIABLE DEPTH.

DRIVEWAY PAVEMENT REMOVAL

Where existing driveway pavement is to be removed, it shall be removed along with the existing aggregate base to the limits shown on the plans or as directed by the Engineer.

Driveway removal shall be measured in place and the areas computed in square yards. The area measured shall be the actual areas. The contractor shall provide written notification to all property owners a minimum of forty-eight (48) hours prior to driveway removal.

The work shall be performed according to Section 440 of the "Standard Specifications" in order to provide a uniform and constant base profile for the new pavement to be placed on.

This work will be paid for at the contract unit price per SQUARE YARD for DRIVEWAY PAVEMENT REMOVAL.

The saw cutting and any additional excavation require to construct the new driveway will be considered incidental to the DRIVEWAY PAVEMENT REMOVAL.

HMA DRIVEWAY 4"

Where existing HMA driveways are removed, as directed by the Engineer, they shall be restored with a six-inch (6") aggregate base course, an application of Bituminous Materials (Prime Coat) at a rate of 0.25 pounds per square foot, and four inches (4") of Hot-Mix Asphalt Surface Course, Mix "D", N50. A maximum width of driveway replacement shall be from the existing back of curb to the existing face of sidewalk unless agreed to otherwise by the Engineer. This work shall be done in accordance with Sections 351, 406, and 440 of the Standard Specifications.

At the direction of the engineer access to properties shall be maintained throughout the duration of construction by means of temporary aggregate in accordance with Articles 107.09 and 402.10 of the Standard Specifications. The temporary aggregate shall be paid for at the contract unit price per TON for AGGREGATE FOR TEMPORARY ACCESS.

All grassed areas disturbed by the removal and replacement of this item shall be restored in accordance with the SODDING, SPECIAL, Special Provision contained herein, and shall be paid for at the contract unit price per SQUARE YARD for SODDING, SPECIAL.

The saw cutting and any additional excavation required to construct these driveways will be considered incidental to the driveway removal. The placement of a minimum six inches (6") of CA 6 stone will be considered incidental to driveway placement. This work will be paid for at the contract unit price per SQUARE YARD for HMA DRIVEWAY 4".

#### PCC DRIVEWAY PAVEMENT 6"

Where existing concrete driveways are removed, as directed by the Engineer, they shall be restored with a minimum four inches (4") of cushion of CA 6 stone and six inches (6") of PC Concrete. This work shall be done in conformance with Sections 423 and 440 of the Standard Specifications. A maximum width of driveway replacement shall be from the existing back of curb to the existing face of sidewalk unless agreed to otherwise by the Engineer. The contractor shall provide written notification shall be given to all property owners a minimum of forty-eight (48) hours prior to driveway removal.

The concrete finish shall match that of the existing driveway (i.e. Broom Finish, California finish, etc.). Any special finish to match the existing driveway and any required removal and replacement of brick pavers adjacent to the concrete driveways shall be considered incidental to the cost of the PCC DRIVEWAY PAVEMENT 6".

At the direction of the engineer access to properties shall be maintained throughout the duration of construction by means of temporary aggregate in accordance with Articles 107.09 and 402.10 of the Standard Specifications. The temporary aggregate shall be paid for at the contract unit price per TON for AGGREGATE FOR TEMPORARY ACCESS.

All grassed areas disturbed by the removal and replacement of this item shall be restored in accordance with the SODDING, SPECIAL, Special Provision contained herein, and shall be paid for at the contract unit price per SQUARE YARD for SODDING, SPECIAL.

The saw cutting and any additional excavation required to construct these driveways will be considered incidental to the driveway removal. The placement of a minimum four inches (4") of CA 6 stone will be considered incidental to driveway placement. This work will be paid for at the contract unit price per SQUARE YARD for PCC DRIVEWAY PAVEMENT 6".

#### SIDEWALK REMOVAL

Where existing sidewalk is to be removed, it shall be removed along with the existing aggregate base. This work shall be performed in accordance with Section 440 of the Standard Specifications.

Sidewalk removal shall be measured in place and the areas computed in square feet. The area measured shall be the actual areas.

This work will be paid for at the contract unit price per SQUARE FEET for SIDEWALK REMOVAL.

The saw cutting and any additional excavation require to construct the new sidewalk will be considered incidental to the SIDEWALK REMOVAL.

#### PORTLAND CEMENT CONCRETE SIDEWALK 5"

Where existing concrete sidewalks are removed as directed by the Engineer, they shall be restored with a minimum of four inches (4") CA-6 stone and five inches (5") of PC Concrete. This work shall be done in accordance with Section 424 of the Standard Specifications, and as detailed in the plans by means of a sawed joint (straight) at locations shown on the plans or as designated by the Engineer in the field.

This work shall be paid for at the contract unit price per SQUARE FOOT for PORTLAND CEMENT CONCRETE SIDEWALK 5"

All grassed areas disturbed by removal or construction of the sidewalk shall be restored in accordance with the SODDING, SPECIAL, Special Provision contained herein and shall be paid for at the contract unit price per SQUARE YARD for SODDING, SPECIAL.

Regrading of adjacent grass areas due to sidewalk elevation changes will be considered incidental to the PORTLAND CEMENT CONCRETE SIDEWALK 5".

#### COMBINATION CURB AND GUTTER REMOVAL

This item shall consist of the removal of combination concrete curb and gutter, and existing aggregate base, in accordance with Sections 440 of the Standard Specifications, and as detailed in the plans by means of a sawed joint (straight) at locations as designated by the Engineer. On Hot Mix Asphalt (HMA) streets the contractor will be required to sawcut 8" off the edge of pavement.

This work will be paid for at the contract unit price per FOOT for COMBINATION CURB AND GUTTER REMOVAL, and shall include saw cutting, disposal.

The removal of the 8" wedge will be incidental to COMBINATION CURB AND GUTTER REMOVAL.

Access to all properties shall be maintained throughout the duration of construction by means of temporary aggregate in accordance with Articles 107.09 and 402.10 of the Standard Specifications. The temporary aggregate shall be paid for at the contract unit price per TON for AGGREGATE FOR TEMPORARY ACCESS.

#### COMBINATION CONCRETE CURB AND GUTTER, TYPE B-6.12 (MODIFIED)

This item shall consist of the replacement of combination concrete curb and gutter, in accordance with Section 606 of the Standard Specifications, and the curb detail B-6.12 (modified). New curb shall be installed on a minimum of four inch (4") CA-6 stone.

All new curb and gutter shall have sawcut contraction joints two inches (2") deep at fifteen foot (15') intervals. This sawcutting shall be completed no later than twenty-four (24) hours after the curb and gutter has been poured. All joints shall be cleaned and sealed with joint sealant. Expansion and construction joints shall be as directed by the Standard Specifications and Standard Drawings. Three quarter inch (3/4") preformed joint filler shall be placed at the ends of all replaced sections, radii, P.C.'s, at five feet (5') each side of drainage structures, and at maximum intervals of 60 feet.

Where new curb meets existing curb, the existing curb shall be drilled and two (2) #5 smooth dowel bars grouted in place with the grease cap placed on the side of the new curb and gutter.

The void between the existing base and the new gutter will be filled with a minimum thickness of eight inches (8") of concrete. This concrete wedge will be placed after the curb and gutter has been poured and the framing has been removed. The placement of the concrete wedge will be included in the cost of this item.

This work will be paid for at the contract unit price per FOOT for COMBINATION CONCRETE CURB AND GUTTER, TYPE B-6.12 (MODIFIED), and shall include materials, labor, equipment, dowel bars, proposed concrete wedge, required expansion material that is required due to the installation of the curb or curb and gutter. Restoration (topsoil, and sodding) for areas disturbed by curb removal and replacement shall be paid separately.

#### DETECTABLE WARNINGS

This item shall consist of the placement of detectable warning plates in accordance with the IDOT Standard drawings and in accordance with Article 424.09 of the Standard Specifications. The detectable warning plate(s) shall be polymer composite material red in color and meet the Village of Villa Park Standards. The Contractor is responsible for the installation of the device according to the manufacturer's specifications and the handicap ramp as described in the contract plans and specifications. This work will be paid for at the contract unit price per SQUARE FOOT for DETECTABLE WARNINGS and will include all materials, equipment and labor required to complete the work as specified above.

#### STORM SEWER, PVC SDR 26, 12"

The PVC storm sewer shall be SDR 26 conforming to ASTM D-2241 specifications with bell and spigot joints conforming to ASTM D-3212 having rubber gaskets (ASTM F-477). The PVC storm sewer shall be installed in accordance with applicable portions of Section 550 of the Standard Specification. Bedding material shall be a minimum of four inches (4") of CA-11 and shall extend to a minimum of 12 inches above the top of the pipe.

This work will be paid for at the contract unit price per FOOT for STORM SEWER, PVC SDR 26, [SIZE SPECIFIED], which price shall be payment in full for all labor, material and equipment necessary for the installation of the new sewer and all other work as specified herein. Bedding material and initial backfill shall also be included in the price of the storm sewer. Trench Backfill, for those areas defined above, will be provided in accordance with Section 208 and paid for under TRENCH BACKFILL.

The connections to the existing structures will be incidental to STORM SEWER, PVC SDR 26.

#### STRUCTURES TO BE ADJUSTED

This work shall consist of the adjustment of drainage and utility structures at those locations as indicated in the plans or as directed by the engineer in the field. This work shall be completed in accordance with the applicable portions of Section 602 of the Standard Specifications. All adjustments shall be made with concrete adjustment rings unless otherwise directed by the Engineer. The cost for the concrete adjustment rings will be included in the cost of the structure adjustment.

All proposed and existing structures are to be adjusted to finish grade after the level binder has been placed. The pavement disturbed by the adjustment shall be replaced with eight inch (8") thick high-early strength concrete base course to the grade of the newly placed level binder. The removal and replacement of the pavement around the adjusted structures shall be included in the cost of this item. All trench backfill of structures to be adjusted will also be included in the cost of the structure to be adjusted. This work will be paid for at the contract unit price EACH for STRUCTURES TO BE ADJUSTED.

The top adjusting ring on all structures to be adjusted shall be a rubber fibrepolyurethane prepolymer composite adjusting ring (minimum 1" thick) as approved by the engineer. Tapered adjusting rings shall be used where necessary to match the profile of the pavement. The cost for the rubber adjusting rings will be included in the cost of the structure adjustment.

#### STRUCTURES TO BE RECONSTRUCTED

This work shall consist of the reconstruction of drainage and utility structures at those locations as indicated in the plans or as directed by the engineer in the field. This work shall be completed in accordance with the applicable portions of Section 602 of the Standard Specifications.

All existing structures which are reconstructed shall be adjusted to finish grade after the level binder has been placed. The pavement disturbed by the reconstruction shall be replaced with eight inch (8") thick high-early strength concrete base course to the grade of the newly placed level binder. The removal and replacement of the pavement around the reconstructed structures shall be included in the cost of this item. All trench backfill of structures to be reconstructed will also be included in the cost of the structure to be reconstructed. This work will be paid for at the contract unit price EACH for STRUCTURES TO BE RECONSTRUCTED

The top adjusting ring on all structures to be reconstructed shall be a rubber fibrepolyurethane prepolymer composite adjusting ring (minimum 1" thick) as approved by the engineer. Tapered adjusting rings shall be used where necessary to match the profile of the pavement. The cost for the rubber and concrete adjusting rings will be included in the cost of the structure to be reconstructed.

#### TYPE 1 FRAME AND ADA GRATE

This work shall consist of the furnishing a type 1 frame and ADA grate. This pay item shall be in accordance with the applicable portions of Section 602 of the Standard Specifications and the ADA grate detail.

This work shall be paid for at the contract unit price per EACH for TYPE 1 FRAME AND ADA GRATE.

PIPE UNDERDRAINS, FABRIC LINED TRENCH 4"

This work shall consist of furnishing all materials, including factory plug on any underdrain ends not connected to structures, equipment and labor required for the installation of pipe underdrains in a geotechnical fabric sock in accordance with the applicable portions of Section 601 of the Standard Specifications and as shown on the details in the plans. Bedding material shall be a minimum of four inches (4") of CA-11 and shall extend to a minimum of 12 inches above the top of the pipe.

The geotechnical fabric shall meet the material requirements specified in Section 1080.01 of the Standard Specifications. The pipe shall be perforated PVC ASTM 2241, SDR 26 in accordance with Section 1040.03 or 1040.04.

Pipe underdrains shall be measured for payment in feet in place. Geotechnical fabric, excavation or backfill will not be measured separately for payment.

This work will be paid for at the contract unit price per FOOT for PIPE UNDERDRAINS, FABRIC LINED TRENCH 4", which price shall include the furnishing of pipe underdrain and connecting hardware, all excavation and disposal of surplus material excavated from the trench, furnishing and placing the geotechnical fabric, placing the pipe in the trench, furnishing and placing bedding, backfilling with aggregate, and all other labor and equipment necessary to complete the work as indicated in the plans. The depth of the underdrain shall be as directed by the ENGINEER, however for bidding purposes this will be assumed at 3.2'.

The coring of the existing structures and any fittings required to connect the underdrains will be incidental to PIPE UNDERDRAINS, FABRIC LINED TRENCH 4".

AGGREGATE WEDGE SHOULDER, TYPE B, SPECIAL

In the areas where aggregate shoulder is called for, a shoulder shall be constructed in accordance with Section 481.07 except that the depth of the aggregate near the edge of the roadway shall be a minimum of 6" thick. The excavation required to meet this depth shall be included in the unit cost of this item. The width of the shoulder shall be 18" wide as measured from the edge of pavement and the thickness at the outside edge shall be a minimum of 2". The new aggregate shall be placed on a compacted base.

This work will be paid for at the contract unit price per TON for AGGREGATE WEDGE SHOULDER, TYPE B, SPECIAL and will include all materials, equipment and labor required to complete the work as specified above.

AGGREGATE FOR TEMPORARY ACCESS

This work shall consist of furnishing and placing crushed stone with a gradation number of CA 6, conforming to Article 1004.01 of the Standard Specifications, for the purpose of maintaining access to private property or along public right-of-way during the construction period.

When the use of the temporary approaches is discontinued, the aggregate placed in its construction and maintenance shall be removed and disposed of as specified in Article 202.03 or included in the permanent roadway construction.

This work will be paid for at the contract unit price per TON for AGGREGATE FOR TEMPORARY ACCESS, which price shall include all costs of furnishing, placing, removing and disposing of aggregate used in the construction of temporary approaches. This aggregate will only be paid for once, regardless of the number of times it is used for temporary access. It will also only be paid for under one item if used for other purposes.

QUANTITIES FOR PAVEMENT PATCHING

The quantities called for in this contract indicate the approximate amount of patching work to be expected. The actual amount for the various patching items shall be as marked out by the engineer in the field. It shall be understood and agreed upon that the unit price for these items shall prevail throughout the period of the contract and that no additional compensation per unit price will be allowed for any increase or decrease in the patching quantity.

PATCHING LIMITATIONS

It is hereby understood and agreed that no pavement patching will be permitted after 3:00 PM on Friday of each and every week and no holes will be allowed to remain open overnight or over the weekend.

SODDING, SPECIAL

This work shall consist of preparing the ground surface, furnishing and applying topsoil to a 4" depth, fertilizing the areas to be sodded, and furnishing and placing the sod. The locations to be sodded shall be those grassed areas disturbed by curb and gutter installation and driveway removal and replacement operations. All work shall be in accordance with the applicable portions of Section 211 and 252 of the Standard Specifications. The maximum pay width shall be twenty-four inches (24") on either side of driveways, and twenty-four inches (24") back of curb installed or as directed by the Engineer.

180 pounds of fertilizer nutrients per acre shall be applied at a 1:1:1 ratio as follows:

- |                                   |            |
|-----------------------------------|------------|
| 1. Nitrogen Fertilizer Nutrient   | 60 lb/acre |
| 2. Phosphorus Fertilizer Nutrient | 60 lb/acre |
| 3. Potassium Fertilizer Nutrient  | 60 lb/acre |

Watering shall be as specified in the Standard Specifications and shall be the contractor's responsibility to guarantee the growth of the sod regardless of the number of waterings required.

This work shall be measured in place and the area calculated in square yards and shall be paid for at the contract unit price bid per SQUARE YARD for SODDING, (SPECIAL) which price shall be full compensation for all labor, equipment, and material to complete the work as specified in these special provisions.

CLEAN CONSTRUCTION / DEMOLITION DEBRIS (CCDD) REQUIREMENTS PER PA 94-1416

If the Contractor is planning on disposing of uncontaminated soils at an Illinois Environmental Protection Agency (IEPA) permitted CCDD facility, the work shall be conducted in accordance with the criteria set forth in 35 Illinois Administrative Code (IAC) 1100. The following protocol must be followed:

1. Expose soils at one or more distinct locations as directed by the Engineer and/or the Licensed Professional Engineer or Licensed Professional Geologist retained by the Contractor. The Licensed Professional Engineer or Licensed Professional Geologist should determine the number and location of the samples that should be collected for characterization of the excess soil that will be generated during the construction project.
2. Remove one foot or more of overburden to allow for soil sampling at depths specific to the excavation depths of the construction project as directed by the Licensed Professional Engineer or Licensed Professional Geologist.
3. Collect representative grab soil sample(s) for the following laboratory analysis: Volatile Organic Compounds (VOCs), Semi-Volatile Organic Compounds (SVOCs), Pesticides, Polychlorinated Biphenyls (PCBs), Total Metals (RCRA 8) and TCLP Metals (RCRA 8).
4. Submit grab soil sample(s) under a signed chain of custody form to an accredited laboratory for chemical analysis using USEPA Publication No. SW-846 Test Methods (Test Methods for Evaluating Solid Wastes, Physical/Chemical Methods) and in accordance with the requirements outlined in 35 IAC 742 (Tiered Approach to Corrective Action Objectives). The testing shall be conducted on a standard (5 to 7 day) or RUSH (1 to 3 day) turnaround-time as determined by the Contractor and their retained Licensed Professional Engineer or Licensed Professional Geologist. A list of accredited laboratories is available at the IEPA website (<http://www.epa.state.il.us/well/list-accredited-labs.html>).
5. Documentation of any chemical analysis must include but is not limited to:

- Chain of custody control;
  - A copy of the lab analysis;
  - Accreditation status of the laboratory performing the analysis; and
  - Certification by an authorized agent of the laboratory that the analysis has been performed in accordance with the IEPA's rules for the accreditation of environmental laboratories and the scope of the accreditation.
6. If the soil is determined to be clean, the Contractor shall provide the Uncontaminated Soil Certification by Licensed Professional Engineer or Licensed Professional Geologist for Use of Uncontaminated Soil as Fill in a CCDD or Uncontaminated Soil Fill Operation Form (IEPA Form LPC-663) completed and signed by their Licensed Professional Engineer or Licensed Professional Geologist.
7. The Contractor shall provide a copy of all lab analyses and certification forms to the intended CCDD facility and the Engineer.

It is up to the Contractor to coordinate with their intended receiving CCDD facility in advance of bidding to ensure that the facility will accept material from the project area and whether additional laboratory testing or certifications are required for disposal acceptance, beyond what has been outlined above. If the intended CCDD facility selected by the Contractor will require additional documentation or testing, it is the Contractor's responsibility to provide this information and include it in the cost of this item of work. This work shall not be paid for separately but shall be included in the various removal items.

If any contaminated soil is encountered that requires landfill disposal as a non-special waste, special waste or hazardous waste, it will be paid for per Article 109.04 of the Standard Specifications.

#### ADJUSTMENTS AND RECONSTRUCTIONS

Effective: March 15, 2011

Revise the first paragraph of Article 602.04 to read:

"602.04 Concrete. Cast-in-place concrete for structures shall be constructed of Class SI concrete according to the applicable portions of Section 503. Cast-in-place concrete for pavement patching around adjustments and reconstructions shall be constructed of Class PP-1 concrete, unless otherwise noted in the plans, according to the applicable portions of Section 1020."

Revise the third, fourth and fifth sentences of the second paragraph of Article 602.11(c) to read:

"Castings shall be set to the finished pavement elevation so that no subsequent adjustment will be necessary, and the space around the casting shall be filled with Class PP-1 concrete, unless otherwise noted in the plans, to the elevation of the surface of the base course or binder course. HMA surface or binder course material shall not be allowed. The pavement may be opened to traffic according to Article 701.17(e)(3)b."

Revise Article 603.05 to read:

"603.05 Replacement of Existing Flexible Pavement. After the castings have been adjusted, the surrounding space shall be filled with Class PP-1 concrete, unless otherwise noted in the plans, to the elevation of the surface of the base course or binder course. HMA surface or binder course material shall not be allowed. The pavement may be opened to traffic according to Article 701.17(e)(3)b."

Revise Article 603.06 to read:

“603.06 Replacement of Existing Rigid Pavement. After the castings have been adjusted, the pavement and HMA that was removed, shall be replaced with Class PP-1 concrete, unless otherwise noted in the plans, not less than 9 in. (225 mm) thick. The pavement may be opened to traffic according to Article 701.17(e)(3)b.

The surface of the Class PP concrete shall be constructed flush with the adjacent surface.”

Revise the first sentence of Article 603.07 to read:

“603.07 Protection Under Traffic. After the casting has been adjusted and the Class PP concrete has been placed, the work shall be protected by a barricade and two lights according to Article 701.17(e)(3)b.”

DRAINAGE AND INLET PROTECTION UNDER TRAFFIC (DISTRICT 1)

Effective: April 1, 2011

Revised: April 2, 2011

Add the following to Article 603.02 of the Standard Specifications:

- “(i) Temporary Hot-Mix Asphalt (HMA) Ramp (Note 1) ..... 1030
- “(j) Temporary Rubber Ramps (Note 2)

Note 1. The HMA shall have maximum aggregate size of 3/8 in. (95 mm).

Note 2. The rubber material shall be according to the following.

Property	Test Method	Requirement
Durometer Hardness, Shore A	ASTM D 2240	75 ±15
Tensile Strength, psi (kPa)	ASTM D 412	300 (2000) min
Elongation, percent	ASTM D 412	90 min
Specific Gravity	ASTM D 792	1.0 - 1.3
Brittleness, °F (°C)	ASTM D 746	-40 (-40)”

Revise Article 603.07 of the Standard Specifications to read:

“603.07 Protection Under Traffic. After the casting has been adjusted and the Class PP concrete has been placed, the work shall be protected by a barricade and two lights according to Article 701.17(e)(3)b.

When castings are under traffic before the final surfacing operation has been started, properly sized temporary ramps shall be placed around the drainage and/or utility castings according to the following methods.

- (a) Temporary Asphalt Ramps. Temporary hot-mix asphalt ramps shall be placed around the casting, flush with its surface and decreasing to a featheredge in a distance of 2 ft (600 mm) around the entire surface of the casting.
- (b) Temporary Rubber Ramps. Temporary rubber ramps shall only be used on roadways with permanent posted speeds of 40 mph or less and when the height of the casting to be protected meets the proper sizing requirements for the rubber ramps as shown below.

Dimension	Requirement

Inside Opening	Outside dimensions of casting + 1 in. (25 mm)
Thickness at inside edge	Height of casting $\pm$ 1/4 in. (6 mm)
Thickness at outside edge	1/4 in. (6 mm) max.
Width, measured from inside opening to outside edge	8 1/2 in. (215 mm) min

Placement shall be according to the manufacturer's specifications.

Temporary ramps for castings shall remain in place until surfacing operations are undertaken within the immediate area of the structure. Prior to placing the surface course, the temporary ramp shall be removed. Excess material shall be disposed of according to Article 202.03."

FINE AGGREGATE FOR HOT-MIX ASPHALT (HMA) (D-1)

Effective: May 1, 2007

Revised: January 1, 2012

Revise Article 1003.03 (c) of the Standard Specifications to read:

"(c) Gradation. The fine aggregate gradation for all HMA shall be FA1, FA 2, FA 20, FA 21 or FA 22. When Reclaimed Asphalt Pavement (RAP) is incorporated in the HMA design, the use of FA 21 Gradation will not be permitted.

FRICTION SURFACE AGGREGATE (D1)

Effective: January 1, 2011

Revised: November 1, 2013

Revise Article 1004.01(a)(4) of the Standard Specifications to read:

"(4) Crushed Stone. Crushed stone shall be the angular fragments resulting from crushing undisturbed, consolidated deposits of rock by mechanical means. Crushed stone shall be divided into the following, when specified.

- a. Carbonate Crushed Stone. Carbonate crushed stone shall be either dolomite or limestone. Dolomite shall contain 11.0 percent or more magnesium oxide (MgO). Limestone shall contain less than 11.0 percent magnesium oxide (MgO).
- b. Crystalline Crushed Stone. Crystalline crushed stone shall be either metamorphic or igneous stone, including but is not limited to, quartzite, granite, rhyolite and diabase."

Revise Article 1004.03(a) of the Standard Specifications to read:

"1004.03 Coarse Aggregate for Hot-Mix Asphalt (HMA). The aggregate shall be according to Article 1004.01 and the following revisions.

(a) Description. The coarse aggregate for HMA shall be according to the following table.

Use	Mixture	Aggregates Allowed
-----	---------	--------------------

Use	Mixture	Aggregates Allowed						
Class A	Seal or Cover	<u>Allowed Alone or in Combination:</u> Gravel Crushed Gravel Carbonate Crushed Stone Crystalline Crushed Stone Crushed Sandstone Crushed Slag (ACBF) Crushed Steel Slag Crushed Concrete						
HMA All Other	Shoulders	<u>Allowed Alone or in Combination:</u> Gravel Crushed Gravel Carbonate Crushed Stone Crystalline Crushed Stone Crushed Sandstone Crushed Slag (ACBF) <sup>1/</sup> Crushed Steel Slag <sup>1/</sup> Crushed Concrete						
HMA High ESAL Low ESAL	C Surface IL-12.5,IL-9.5, or IL-9.5L	<u>Allowed Alone or in Combination:</u> Crushed Gravel Carbonate Crushed Stone Crystalline Crushed Stone Crushed Sandstone Crushed Slag (ACBF) <sup>1/</sup> Crushed Steel Slag <sup>1/</sup> Crushed Concrete						
HMA High ESAL	D Surface IL-12.5 or IL-9.5	<u>Allowed Alone or in Combination:</u> Crushed Gravel Carbonate Crushed Stone (other than Limestone) Crystalline Crushed Stone Crushed Sandstone Crushed Slag (ACBF) <sup>1/</sup> Crushed Steel Slag <sup>1/</sup> Crushed Concrete						
		<u>Other Combinations Allowed:</u>						
		<table border="1"> <thead> <tr> <th>Up to...</th> <th>With...</th> </tr> </thead> <tbody> <tr> <td>25% Limestone</td> <td>Dolomite</td> </tr> <tr> <td>50% Limestone</td> <td>Any Mixture D aggregate other than Dolomite</td> </tr> </tbody> </table>	Up to...	With...	25% Limestone	Dolomite	50% Limestone	Any Mixture D aggregate other than Dolomite
Up to...	With...							
25% Limestone	Dolomite							
50% Limestone	Any Mixture D aggregate other than Dolomite							

Use	Mixture	Aggregates Allowed	
		75% Limestone	Crushed Slag (ACBF) <sup>1/</sup> or Crushed Sandstone
HMA High ESAL	F Surface IL-12.5 or IL-9.5	<u>Allowed Alone or in Combination:</u>  Crystalline Crushed Stone Crushed Sandstone Crushed Slag (ACBF) <sup>1/</sup> Crushed Steel Slag <sup>1/</sup>  No Limestone or no Crushed Gravel alone.	
		<u>Other Combinations Allowed:</u> Up to... With...	
		50% Crushed Gravel, or Dolomite	Crushed Sandstone, Crushed Slag (ACBF) <sup>1/</sup> , Crushed Steel Slag <sup>1/</sup> , or Crystalline Crushed Stone
HMA High ESAL	SMA Ndesign 80 Surface	Crystalline Crushed Stone Crushed Sandstone Crushed Steel Slag	

1/ When either slag is used, the blend percentages listed shall be by volume.

Add the following to Article 1004.03 (b):

“ When using Crushed Concrete, the quality shall be determined as follows. The Contractor shall obtain a representative sample from the stockpile, witnessed by the Engineer, at a frequency of 2500 tons (2300 metric tons). The sample shall be a minimum of 50 lb (25 kg). The Contractor shall submit the sample to the District Office. The District will forward the sample to the BMR Aggregate Lab for MicroDeval Testing, according to Illinois Modified AASHTO T 327. A maximum loss of 15.0 percent by weight will be applied for acceptance. The stockpile shall be sealed until test results are complete and found to meet the specifications above.”

GROUND TIRE RUBBER (GTR) MODIFIED ASPHALT BINDER (D-1)

Effective: June 26, 2006

Revised: January 1, 2013

Add the following to the end of article 1032.05 of the Standard Specifications:

“(c) Ground Tire Rubber (GTR) Modified Asphalt Binder. A quantity of 10.0 to 14.0 percent GTR (Note 1) shall be blended by dry unit weight with a PG 64-28 to make a GTR 70-28 or a PG 58-28 to make a GTR 64-28. The base PG 64-28 and PG 58-28 asphalt binders shall meet the requirements of Article 1032.05(a). Compatible polymers may be added during production. The GTR modified asphalt binder shall meet the requirements of the following table.

Test	Asphalt Grade GTR 70-28	Asphalt Grade GTR 64-28
Flash Point (C.O.C.), AASHTO T 48, °F (°C), min.	450 (232)	450 (232)
Rotational Viscosity, AASHTO T 316 @ 275 °F (135 °C), Poises, Pa·s, max.	30 (3)	30 (3)
Softening Point, AASHTO T 53, °F (°C), min.	135 (57)	130 (54)
Elastic Recovery, ASTM D 6084, Procedure A (sieve waived) @ 77 °F, (25 °C), aged, ss, 100 mm elongation, 5 cm/min., cut immediately, %, min.	65	65

Note 1. GTR shall be produced from processing automobile and/or light truck tires by the ambient grinding method. GTR shall not exceed 1/16 in. (2 mm) in any dimension and shall contain no free metal particles or other materials. A mineral powder (such as talc) meeting the requirements of AASHTO M 17 may be added, up to a maximum of four percent by weight of GTR to reduce sticking and caking of the GTR particles. When tested in accordance with Illinois modified AASHTO T 27, a 50 g sample of the GTR shall conform to the following gradation requirements:

Sieve Size	Percent Passing
No. 16 (1.18 mm)	100
No. 30 (600 μm)	95 ± 5
No. 50 (300 μm)	> 20

Add the following to the end of Note 1. of article 1030.03 of the Standard Specifications:

“A dedicated storage tank for the Ground Tire Rubber (GTR) modified asphalt binder shall be provided. This tank must be capable of providing continuous mechanical mixing throughout by continuous agitation and recirculation of the asphalt binder to provide a uniform mixture. The tank shall be heated and capable of maintaining the temperature of the asphalt binder at 300 °F to 350 °F (149 °C to 177 °C). The asphalt binder metering systems of dryer drum plants shall be calibrated with the actual GTR modified asphalt binder material with an accuracy of ± 0.40 percent.”

Revise 1030.02(c) of the Standard Specifications to read:

“(c) RAP Materials (Note 3) .....1031”

Add the following note to 1030.02 of the Standard Specifications:

Note 3. When using reclaimed asphalt pavement and/or reclaimed asphalt shingles, the maximum asphalt binder replacement percentage shall be according to the most recent special provision for recycled materials.

### RECLAIMED ASPHALT PAVEMENT AND RECLAIMED ASPHALT SHINGLES (D-1)

Effective: November 1, 2012

Revise: April 2, 2015

Revise Section 1031 of the Standard Specifications to read:

#### “SECTION 1031. RECLAIMED ASPHALT PAVEMENT AND RECLAIMED ASPHALT SHINGLES

1031.01 Description. Reclaimed asphalt pavement and reclaimed asphalt shingles shall be according to the following.

- (a) Reclaimed Asphalt Pavement (RAP). RAP is the material resulting from cold milling or crushing an existing hot-mix asphalt (HMA) pavement. RAP will be considered processed FRAP after completion of both crushing and screening to size. The Contractor shall supply written documentation that the RAP originated from routes or airfields under federal, state, or local agency jurisdiction.
- (b) Reclaimed Asphalt Shingles (RAS). Reclaimed asphalt shingles (RAS). RAS is from the processing and grinding of preconsumer or post-consumer shingles. RAS shall be a clean and uniform material with a maximum of 0.5 percent unacceptable material, as defined in Bureau of Materials and Physical Research Policy Memorandum “Reclaimed Asphalt Shingle (RAS) Sources”, by weight of RAS. All RAS used shall come from a Bureau of Materials and Physical Research approved processing facility where it shall be ground and processed to 100 percent passing the 3/8 in. (9.5 mm) sieve and 90 percent passing the #4 (4.75 mm) sieve. RAS shall meet the testing requirements specified herein. In addition, RAS shall meet the following Type 1 or Type 2 requirements.
  - (1) Type 1. Type 1 RAS shall be processed, preconsumer asphalt shingles salvaged from the manufacture of residential asphalt roofing shingles.
  - (2) Type 2. Type 2 RAS shall be processed post-consumer shingles only, salvaged from residential, or four unit or less dwellings not subject to the National Emission Standards for Hazardous Air Pollutants (NESHAP).

1031.02 Stockpiles. RAP and RAS stockpiles shall be according to the following.

- (a) RAP Stockpiles. The Contractor shall construct individual, sealed RAP stockpiles meeting one of the following definitions. Additional processed RAP (FRAP) shall be stockpiled in a separate working pile, as designated in the QC Plan, and only added to the sealed stockpile when test results for the working pile are complete and are found to meet tolerances specified herein for the original sealed FRAP stockpile. Stockpiles shall be sufficiently separated to prevent intermingling at the base. All stockpiles (including unprocessed RAP and FRAP) shall be identified by signs indicating the type as listed below (i.e. “Non- Quality, FRAP -#4 or Type 2 RAS”, etc...).
  - (1) Fractionated RAP (FRAP). FRAP shall consist of RAP from Class I, Superpave HMA (High and Low ESAL) or equivalent mixtures. The coarse aggregate in FRAP shall be crushed aggregate and may represent more than one aggregate type and/or quality but shall be at least C quality. All FRAP shall be processed prior to testing and sized into fractions with the separation occurring on or between the #4 (4.75 mm) and 1/2 in. (12.5 mm) sieves. Agglomerations shall be minimized such that 100 percent of the RAP in the coarse fraction shall pass the maximum sieve size specified for the mix the FRAP will be used in.

- (2) Restricted FRAP (B quality) stockpiles shall consist of RAP from Class I, Superpave (High ESAL), or HMA (High ESAL). If approved by the Engineer, the aggregate from a maximum 3.0 inch single combined pass of surface/binder milling will be classified as B quality. All millings from this application will be processed into FRAP as described previously.
- (3) Conglomerate. Conglomerate RAP stockpiles shall consist of RAP from Class I, Superpave HMA (High and Low ESAL) or equivalent mixtures. The coarse aggregate in this RAP shall be crushed aggregate and may represent more than one aggregate type and/or quality but shall be at least C quality. This RAP may have an inconsistent gradation and/or asphalt binder content prior to processing. All conglomerate RAP shall be processed (FRAP) prior to testing. Conglomerate RAP stockpiles shall not contain steel slag or other expansive material as determined by the Department.
- (4) Conglomerate "D" Quality (DQ). Conglomerate DQ RAP stockpiles shall consist of RAP from HMA shoulders, bituminous stabilized subbases or Superpave (Low ESAL)/HMA (Low ESAL) IL-19.0L binder mixture. The coarse aggregate in this RAP may be crushed or round but shall be at least D quality. This RAP may have an inconsistent gradation and/or asphalt binder content. Conglomerate DQ RAP stockpiles shall not contain steel slag or other expansive material as determined by the Department.
- (5) Non-Quality. RAP stockpiles that do not meet the requirements of the stockpile categories listed above shall be classified as "Non-Quality".

RAP or FRAP containing contaminants, such as earth, brick, sand, concrete, sheet asphalt, bituminous surface treatment (i.e. chip seal), pavement fabric, joint sealants, plant cleanout etc., will be unacceptable unless the contaminants are removed to the satisfaction of the Engineer. Sheet asphalt shall be stockpiled separately.

- (b) RAS Stockpiles. Type 1 and Type 2 RAS shall be stockpiled separately and shall be sufficiently separated to prevent intermingling at the base. Each stockpile shall be signed indicating what type of RAS is present. However, a RAS source may submit a written request to the Department for approval to blend mechanically a specified ratio of type 1 RAS with type 2 RAS. The source will not be permitted to change the ratio of the blend without the Department prior written approval. The Engineer's written approval will be required, to mechanically blend RAS with any fine aggregate produced under the AGCS, up to an equal weight of RAS, to improve workability. The fine aggregate shall be "B Quality" or better from an approved Aggregate Gradation Control System source. The fine aggregate shall be one that is approved for use in the HMA mixture and accounted for in the mix design and during HMA production.

Records identifying the shingle processing facility supplying the RAS, RAS type and lot number shall be maintained by project contract number and kept for a minimum of three years.

1031.03 Testing. FRAP and RAS testing shall be according to the following.

- (a) FRAP Testing. When used in HMA, the FRAP shall be sampled and tested either during processing or after stockpiling. It shall also be sampled during HMA production.
  - (1) During Stockpiling. For testing during stockpiling, washed extraction samples shall be run at the minimum frequency of one sample per 500 tons (450 metric tons) for the first 2000 tons (1800 metric tons) and one sample per 2000 tons (1800 metric tons) thereafter. A minimum of five tests shall be required for stockpiles less than 4000 tons (3600 metric tons).
  - (2) Incoming Material. For testing as incoming material, washed extraction samples shall be run at a minimum frequency of one sample per 2000 tons (1800 metric tons) or once per week, whichever comes first.

- (3) After Stockpiling. For testing after stockpiling, the Contractor shall submit a plan for approval to the District proposing a satisfactory method of sampling and testing the RAP/FRAP pile either in-situ or by restockpiling. The sampling plan shall meet the minimum frequency required above and detail the procedure used to obtain representative samples throughout the pile for testing.

Before extraction, each field sample of FRAP, shall be split to obtain two samples of test sample size. One of the two test samples from the final split shall be labeled and stored for Department use. The Contractor shall extract the other test sample according to Department procedure. The Engineer reserves the right to test any sample (split or Department-taken) to verify Contractor test results.

- (b) RAS Testing. RAS shall be sampled and tested during stockpiling according to Bureau of Materials and Physical Research Policy Memorandum, "Reclaimed Asphalt Shingle (RAS) Sources". The Contractor shall also sample as incoming material at the HMA plant.
- (1) During Stockpiling. Washed extraction and testing for unacceptable materials shall be run at the minimum frequency of one sample per 200 tons (180 metric tons) for the first 1000 tons (900 metric tons) and one sample per 1000 tons (900 metric tons) thereafter. A minimum of five samples are required for stockpiles less than 1000 tons (900 metric tons). Once a  $\leq 1000$  ton (900 metric ton), five-sample/test stockpile has been established it shall be sealed. Additional incoming RAS shall be in a separate working pile as designated in the Quality Control plan and only added to the sealed stockpile when the test results of the working pile are complete and are found to meet the tolerances specified herein for the original sealed RAS stockpile.
- (2) Incoming Material. For testing as incoming material at the HMA plant, washed extraction shall be run at the minimum frequency of one sample per 250 tons (227 metric tons). A minimum of five samples are required for stockpiles less than 1000 tons (900 metric tons). The incoming material test results shall meet the tolerances specified herein.

The Contractor shall obtain and make available all test results from start of the initial stockpile sampled and tested at the shingle processing facility in accordance with the facility's QC Plan.

Before extraction, each field sample shall be split to obtain two samples of test sample size. One of the two test samples from the final split shall be labeled and stored for Department use. The Contractor shall extract the other test sample according to Department procedures. The Engineer reserves the right to test any sample (split or Department-taken) to verify Contractor test results.

1031.04 Evaluation of Tests. Evaluation of tests results shall be according to the following.

- (a) Evaluation of FRAP Test Results. All test results shall be compiled to include asphalt binder content, gradation and, when applicable (for slag),  $G_{mm}$ . A five test average of results from the original pile will be used in the mix designs. Individual extraction test results run thereafter, shall be compared to the average used for the mix design, and will be accepted if within the tolerances listed below.

Parameter	FRAP
No. 4 (4.75 mm)	$\pm 6 \%$
No. 8 (2.36 mm)	$\pm 5 \%$
No. 30 (600 $\mu\text{m}$ )	$\pm 5 \%$
No. 200 (75 $\mu\text{m}$ )	$\pm 2.0 \%$
Asphalt Binder	$\pm 0.3 \%$
$G_{mm}$	$\pm 0.03$ <sup>1/</sup>

- 1/ For stockpile with slag or steel slag present as determined in the current Manual of Test Procedures Appendix B 21, "Determination of Reclaimed Asphalt Pavement Aggregate Bulk Specific Gravity".

If any individual sieve and/or asphalt binder content tests are out of the above tolerances when compared to the average used for the mix design, the FRAP stockpile shall not be used in Hot-Mix Asphalt unless the FRAP representing those tests is removed from the stockpile. All test data and acceptance ranges shall be sent to the District for evaluation.

The Contractor shall maintain a representative moving average of five tests to be used for Hot-Mix Asphalt production.

With the approval of the Engineer, the ignition oven may be substituted for extractions according to the Illinois Test Procedure, "Calibration of the Ignition Oven for the Purpose of Characterizing Reclaimed Asphalt Pavement (RAP)" or Illinois Modified AASHTO T-164-11, Test Method A.

- (b) Evaluation of RAS Test Results. All of the test results, with the exception of percent unacceptable materials, shall be compiled and averaged for asphalt binder content and gradation. A five test average of results from the original pile will be used in the mix designs. Individual test results run thereafter, when compared to the average used for the mix design, will be accepted if within the tolerances listed below.

Parameter	RAS
No. 8 (2.36 mm)	± 5 %
No. 16 (1.18 mm)	± 5 %
No. 30 (600 µm)	± 4 %
No. 200 (75 µm)	± 2.5 %
Asphalt Binder Content	± 2.0 %

If any individual sieve and/or asphalt binder content tests are out of the above tolerances when compared to the average used for the mix design, the RAS shall not be used in Hot-Mix Asphalt unless the RAS representing those tests is removed from the stockpile. All test data and acceptance ranges shall be sent to the District for evaluation.

- (c) Quality Assurance by the Engineer. The Engineer may witness the sampling and splitting conduct assurance tests on split samples taken by the Contractor for quality control testing a minimum of once a month.

The overall testing frequency will be performed over the entire range of Contractor samples for asphalt binder content and gradation. The Engineer may select any or all split samples for assurance testing. The test results will be made available to the Contractor as soon as they become available.

The Engineer will notify the Contractor of observed deficiencies.

Differences between the Contractor's and the Engineer's split sample test results will be considered acceptable if within the following limits.

Test Parameter	Acceptable Limits of Precision	
	FRAP	RAS
% Passing: <sup>1/</sup>		
1/2 in.	5.0%	
No. 4	5.0%	

No. 8	3.0%	4.0%
No. 30	2.0%	3.0%
No. 200	2.2%	2.5%
Asphalt Binder Content	0.3%	1.0%
G <sub>mm</sub>	0.030	

1/ Based on washed extraction.

In the event comparisons are outside the above acceptable limits of precision, the Engineer will immediately investigate.

- (d) Acceptance by the Engineer. Acceptable of the material will be based on the validation of the Contractor's quality control by the assurance process.

#### 1031.05 Quality Designation of Aggregate in RAP and FRAP.

- (a) RAP. The aggregate quality of the RAP for homogenous, conglomerate, and conglomerate "D" quality stockpiles shall be set by the lowest quality of coarse aggregate in the RAP stockpile and are designated as follows.
- (1) RAP from Class I, Superpave/HMA (High ESAL), or (Low ESAL) IL-9.5L surface mixtures are designated as containing Class B quality coarse aggregate.
  - (2) RAP from Superpave/HMA (Low ESAL) IL-19.0L binder mixture is designated as Class D quality coarse aggregate.
  - (3) RAP from Class I, Superpave/HMA (High ESAL) binder mixtures, bituminous base course mixtures, and bituminous base course widening mixtures are designated as containing Class C quality coarse aggregate.
  - (4) RAP from bituminous stabilized subbase and BAM shoulders are designated as containing Class D quality coarse aggregate.
- (b) FRAP. If the Engineer has documentation of the quality of the FRAP aggregate, the Contractor shall use the assigned quality provided by the Engineer.

If the quality is not known, the quality shall be determined as follows. Fractionated RAP stockpiles containing plus #4 (4.75 mm) sieve coarse aggregate shall have a maximum tonnage of 5,000 tons (4,500 metric tons). The Contractor shall obtain a representative sample witnessed by the Engineer. The sample shall be a minimum of 50 lb (25 kg). The sample shall be extracted according to Illinois Modified AASHTO T 164 by a consultant prequalified by the Department for the specified testing. The consultant shall submit the test results along with the recovered aggregate to the District Office. The cost for this testing shall be paid by the Contractor. The District will forward the sample to the BMPR Aggregate Lab for MicroDeval Testing, according to Illinois Modified AASHTO T 327. A maximum loss of 15.0 percent will be applied for all HMA applications. The fine aggregate portion of the fractionated RAP shall not be used in any HMA mixtures that require a minimum of "B" quality aggregate or better, until the coarse aggregate fraction has been determined to be acceptable thru a MicroDeval Testing.

1031.06 Use of FRAP and/or RAS in HMA. The use of FRAP and/or RAS shall be a Contractor's option when constructing HMA in all contracts.

- (a) FRAP. The use of FRAP in HMA shall be as follows.

- (1) Coarse Aggregate Size (after extraction). The coarse aggregate in all FRAP shall be equal to or less than the nominal maximum size requirement for the HMA mixture to be produced.
  - (2) Steel Slag Stockpiles. FRAP stockpiles containing steel slag or other expansive material, as determined by the Department, shall be homogeneous and will be approved for use in HMA (High ESAL and Low ESAL) mixtures regardless of lift or mix type.
  - (3) Use in HMA Surface Mixtures (High and Low ESAL). FRAP stockpiles for use in HMA surface mixtures (High and Low ESAL) shall have coarse aggregate that is Class B quality or better. FRAP shall be considered equivalent to limestone for frictional considerations unless produced/screened to minus 3/8 inch.
  - (4) Use in HMA Binder Mixtures (High and Low ESAL), HMA Base Course, and HMA Base Course Widening. FRAP stockpiles for use in HMA binder mixtures (High and Low ESAL), HMA base course, and HMA base course widening shall be FRAP in which the coarse aggregate is Class C quality or better.
  - (5) Use in Shoulders and Subbase. FRAP stockpiles for use in HMA shoulders and stabilized subbase (HMA) shall be FRAP, Restricted FRAP, conglomerate, or conglomerate DQ.
- (b) RAS. RAS meeting Type 1 or Type 2 requirements will be permitted in all HMA applications as specified herein.
- (c) FRAP and/or RAS Usage Limits. Type 1 or Type 2 RAS may be used alone or in conjunction with FRAP in HMA mixtures up to a maximum of 5.0% by weight of the total mix.

When FRAP is used alone or FRAP is used in conjunction with RAS, the percent of virgin asphalt binder replacement (ABR) shall not exceed the amounts indicated in the table below for a given N Design.

Max Asphalt Binder Replacement for FRAP with RAS Combination

HMA Mixtures <sup>1/2/4/</sup>	Maximum % ABR			
	Ndesign	Binder/Leveling Binder	Surface	Polymer Modified <sup>3/</sup>
30L		50	40	30
50		40	35	30
70		40	30	30
90		40	30	30
4.75 mm N-50				40
SMA N-80				30

- 1/ For HMA "All Other" (shoulder and stabilized subbase) N-30, the percent asphalt binder replacement shall not exceed 50% of the total asphalt binder in the mixture.
- 2/ When the binder replacement exceeds 15 percent for all mixes, except for SMA and IL-4.75, the high and low virgin asphalt binder grades shall each be reduced by one grade (i.e. 25 percent binder replacement using a virgin asphalt binder grade of PG64-22 will be reduced to a PG58-28). When constructing full depth HMA and the ABR is less than 15 percent, the required virgin asphalt binder grade shall be PG64-28.
- 3/ When the ABR for SMA or IL-4.75 is 15 percent or less, the required virgin asphalt binder shall be SBS PG76-22 and the elastic recovery shall be a minimum of 80. When the ABR for SMA or IL-4.75 exceeds 15%, the virgin asphalt binder grade shall be SBS PG70-28 and the elastic recovery shall be a minimum of 80.

- 4/ When FRAP or RAS is used alone, the maximum percent asphalt binder replacement designated on the table shall be reduced by 10 percent.

1031.07 HMA Mix Designs. At the Contractor's option, HMA mixtures may be constructed utilizing RAP/FRAP and/or RAS material meeting the detailed requirements specified herein.

- (a) FRAP and/or RAS. FRAP and /or RAS mix designs shall be submitted for verification. If additional FRAP or RAS stockpiles are tested and found to be within tolerance, as defined under "Evaluation of Tests" herein, and meet all requirements herein, the additional FRAP or RAS stockpiles may be used in the original design at the percent previously verified.
- (b) RAS. Type 1 and Type 2 RAS are not interchangeable in a mix design. A RAS stone bulk specific gravity (Gsb) of 2.300 shall be used for mix design purposes.

1031.08 HMA Production. HMA production utilizing FRAP and/or RAS shall be as follows.

To remove or reduce agglomerated material, a scalping screen, gator, crushing unit, or comparable sizing device approved by the Engineer shall be used in the RAS and FRAP feed system to remove or reduce oversized material. If material passing the sizing device adversely affects the mix production or quality of the mix, the sizing device shall be set at a size specified by the Engineer.

If during mix production, corrective actions fail to maintain FRAP, RAS or QC/QA test results within control tolerances or the requirements listed herein the Contractor shall cease production of the mixture containing FRAP or RAS and conduct an investigation that may require a new mix design.

- (a) RAS. RAS shall be incorporated into the HMA mixture either by a separate weight depletion system or by using the RAP weigh belt. Either feed system shall be interlocked with the aggregate feed or weigh system to maintain correct proportions for all rates of production and batch sizes. The portion of RAS shall be controlled accurately to within  $\pm 0.5$  percent of the amount of RAS utilized. When using the weight depletion system, flow indicators or sensing devices shall be provided and interlocked with the plant controls such that the mixture production is halted when RAS flow is interrupted.
- (b) HMA Plant Requirements. HMA plants utilizing FRAP and/or RAS shall be capable of automatically recording and printing the following information.
- (1) Dryer Drum Plants.
- a. Date, month, year, and time to the nearest minute for each print.
  - b. HMA mix number assigned by the Department.
  - c. Accumulated weight of dry aggregate (combined or individual) in tons (metric tons) to the nearest 0.1 ton (0.1 metric ton).
  - d. Accumulated dry weight of RAS and FRAP in tons (metric tons) to the nearest 0.1 ton (0.1 metric ton).
  - e. Accumulated mineral filler in revolutions, tons (metric tons), etc. to the nearest 0.1 unit.
  - f. Accumulated asphalt binder in gallons (liters), tons (metric tons), etc. to the nearest 0.1 unit.

- g. Residual asphalt binder in the RAS and FRAP material as a percent of the total mix to the nearest 0.1 percent.
  - h. Aggregate RAS and FRAP moisture compensators in percent as set on the control panel. (Required when accumulated or individual aggregate and RAS and FRAP are printed in wet condition.)
  - i. When producing mixtures with FRAP and/or RAS, a positive dust control system shall be utilized.
  - j. Accumulated mixture tonnage.
  - k. Dust Removed (accumulated to the nearest 0.1 ton)
- (2) Batch Plants.
- a. Date, month, year, and time to the nearest minute for each print.
  - b. HMA mix number assigned by the Department.
  - c. Individual virgin aggregate hot bin batch weights to the nearest pound (kilogram).
  - d. Mineral filler weight to the nearest pound (kilogram).
  - f. RAS and FRAP weight to the nearest pound (kilogram).
  - g. Virgin asphalt binder weight to the nearest pound (kilogram).
  - h. Residual asphalt binder in the RAS and FRAP material as a percent of the total mix to the nearest 0.1 percent.

The printouts shall be maintained in a file at the plant for a minimum of one year or as directed by the Engineer and shall be made available upon request. The printing system will be inspected by the Engineer prior to production and verified at the beginning of each construction season thereafter.

1031.09 RAP in Aggregate Surface Course and Aggregate Shoulders. The use of RAP or FRAP in aggregate surface course and aggregate shoulders shall be as follows.

- (a) Stockpiles and Testing. RAP stockpiles may be any of those listed in Article 1031.02, except "Non-Quality" and "FRAP". The testing requirements of Article 1031.03 shall not apply. RAP used to construct aggregate surface course and aggregate shoulders shall be according to the current Bureau of Materials and Physical Research's Policy Memorandum, "Reclaimed Asphalt Pavement (RAP) for Aggregate Applications"
- (b) Gradation. One hundred percent of the RAP material shall pass the 1 1/2 in. (37.5mm) sieve. The RAP material shall be reasonably well graded from coarse to fine. RAP material that is gap-graded, FRAP, or single sized will not be accepted for use as Aggregate Surface Course and Aggregate Shoulders."

HOT-MIX ASPHALT – PRIME COAT (D-1)

Effective: February 19, 2013  
Revised: April 1, 2014

Revise Note 1 of Article 406.02 of the Standard Specifications to read:

“Note 1. The bituminous material used for prime coat shall be one of the types listed in the following table.

When emulsified asphalts are used, any dilution with water shall be performed by the emulsion producer. The emulsified asphalt shall be thoroughly agitated within 24 hours of application and show no separation of water and emulsion.

Application	Bituminous Material Types
Prime Coat on Brick, Concrete, or HMA Bases	SS-1, SS-1h, SS-1hP, SS-1vh, CSS-1, CSS-1h, CSS-1hP, HFE-90, RC-70
Prime Coat on Aggregate Bases	MC-30, PEP”

Add the following to Article 406.03 of the Standard Specifications:

“(i) Regenerative Air Vacuum Sweeper.....1101.19”

Revise Article 406.05(b) of the Standard Specifications to read:

“(b) Prime Coat. The bituminous material shall be prepared according to Article 403.05 and applied according to Article 403.10. The use of RC-70 shall be limited to air temperatures less than 60 °F (15 °C).”

- (1) Brick, Concrete or HMA Bases. The base shall be cleaned of all dust, debris and any substance that will prevent the prime coat from adhering to the base. Cleaning shall be accomplished by sweeping to remove all large particles and air blasting to remove dust. As an alternate to air blasting, vacuum sweeping may be used to accomplish the dust removal. Vacuum sweeping shall be accomplished with a regenerative air vacuum sweeper. The base shall be free of standing water at the time of application. The prime coat shall be applied uniformly and at a rate that will provide a residual asphalt rate on the prepared surface as specified in the following table.

Type of Surface to be Primed	Residual Asphalt Rate lb/sq ft (kg/sq m)
Milled HMA, Aged Non-Milled HMA, Milled Concrete, Non-Milled Concrete & Tined Concrete	0.05 (0.244)
Fog Coat between HMA Lifts, IL-4.75 & Brick	0.025 (0.122)

The bituminous material for the prime coat shall be placed one lane at a time. The primed lane shall remain closed until the prime coat is fully cured and does not pickup under traffic. When placing prime coat through an intersection where it is not possible to keep the lane closed, the prime coat may be covered immediately following its application with fine aggregate mechanically spread at a uniform rate of 2 to 4 lb/sq yd (1 to 2 kg/sq m).

- (2) Aggregate Bases. The prime coat shall be applied uniformly and at a rate that will provide a residual asphalt rate on the prepared surface of 0.25 lb/sq ft  $\pm$  0.01 (1.21 kg/sq m  $\pm$  0.05).

The prime coat shall be permitted to cure until the penetration has been approved by the Engineer, but at no time shall the curing period be less than 24 hours for MC-30 or four hours for PEP. Pools of prime occurring in the depressions shall be broomed or squeegeed over the surrounding surface the same day the prime coat is applied.

The base shall be primed 1/2 width at a time. The prime coat on the second half/width shall not be applied until the prime coat on the first half/width has cured so that it will not pick up under traffic.

The residual asphalt binder rate will be verified a minimum of once per type of surface to be primed as specified herein for which at least 2,000 tons of HMA will be placed. The test will be according to the "Determination of Residual Asphalt in Prime and Tack Coat Materials" test procedure.

Prime coat shall be fully cured prior to placement of HMA to prevent pickup by haul trucks or paving equipment. If pickup occurs, paving shall cease in order to provide additional cure time.

Prime coat shall be placed no more than five days in advance of the placement of HMA. If after five days loss of prime coat is evident prior to covering with HMA, additional prime coat shall be placed as determined by the Engineer at no additional cost to the Department."

Revise the last sentence of the first paragraph of 406.13(b) to read:

"Water added to emulsified asphalt at the source as allowed in article 406.02 will not be included in the quantities measured for payment."

Revise the second paragraph of Article 406.13(b) of the Standard Specifications to read:

"Aggregate for covering prime coat will not be measured for payment."

Revise the first paragraph of Article 406.14 and the second paragraph of Article 407.12 of the Standard Specifications to read:

"Prime Coat will be paid for at the contract unit price per pound (kilogram) of residual asphalt applied for BITUMINOUS MATERIALS (PRIME COAT), POLYMERIZED BITUMINOUS MATERIALS (PRIME COAT) or NON-TRACKING BITUMINOUS MATERIALS (PRIME COAT)."

Revise Article 407.06(b) of the Standard Specifications to read:

"A bituminous prime coat shall be applied between each lift of HMA according to Article 406.05(b)."

Revise Article 1032.02 of the Standard Specifications to read:

"1032.02 Measurement. Asphalt binders, emulsified asphalts, rapid curing liquid asphalt, medium curing liquid asphalts, slow curing liquid asphalts, asphalt fillers, and road oils will be measured by weight.

A weight ticket for each truck load shall be furnished to the inspector. The truck shall be weighed at a location approved by the Engineer. The ticket shall show the weight of the empty truck (the truck being weighed each time before it is loaded), the weight of the loaded truck, and the net weight of the bituminous material.

When an emulsion or cutback is used for prime coat, the percentage of asphalt residue of the actual certified product shall be shown on the producer's bill of lading or attached certificate of analysis. If the producer adds extra water to an emulsion at the request of the purchaser, the amount of water shall also be shown on the bill of lading.

Payment will not be made for bituminous materials in excess of 105 percent of the amount specified by the Engineer."

Add the following to the table in article 1032.04 of the Standard Specifications:

"SS-1vh	160 - 180	70 – 80"
---------	-----------	----------

Add the following to Article 1032.06 of the Standard Specifications:

"(g) Non Tracking Emulsified Asphalt SS-1vh:

Requirements for SS-1vh			
Test		SPEC	AASHTO Test Method
Saybolt Viscosity @ 25C,	SFS	20-200	T 72
Storage Stability, 24hr.,	%	1 max.	T 59
Residue by Evaporation,	%	50 min.	T 59
Sieve Test,	%	0.3 max.	T 59
Tests on Residue from Evaporation			
Penetration @25°C, 100g., 5 sec., dmm		20 max.	T 49
Softening Point,	°C	65 min.	T 53
Solubility,	%	97.5 min.	T 44
Orig. DSR @ 82°C,	kPa	1.00 min.	T 315"

Revise the last table of Article 1032.06 to read:

"Grade	Use
SS-1, SS-1h, CSS-1, CSS-1h, HFE-90, SS-1hP, CSS-1hP, SS-1vh	Prime or fog seal
PEP	Bituminous surface treatment prime
RS-2, HFE-90, HFE-150, HFE-300, CRSP, HFP, CRS-2, HFRS-2	Bituminous surface treatment
CSS-1h Latex Modified	Microsurfacing"

Add the following to Article 1101 of the Standard Specifications:

"1101.19 Regenerative Air Vacuum Sweeper. The regenerative air vacuum sweeper shall blast re-circulated, filtered air through a vacuum head having a minimum width of 6.0 feet at a minimum rate of 20,000 cubic feet per minute."

INDEX  
FOR  
SUPPLEMENTAL SPECIFICATIONS  
AND RECURRING SPECIAL PROVISIONS

Adopted January 1, 2015

This index contains a listing of SUPPLEMENTAL SPECIFICATIONS, frequently used RECURRING SPECIAL PROVISIONS, and LOCAL ROADS AND STREETS RECURRING SPECIAL PROVISIONS.

ERRATA Standard Specifications for Road and Bridge Construction  
(Adopted 1-1-12) (Revised 1-1-15)

SUPPLEMENTAL SPECIFICATIONS

<u>Std. Spec. Sec.</u>		<u>Page No.</u>
101	Definition of Terms .....	1
102	Advertisement, Bidding, Award, and Contract Execution .....	2
105	Control of Work .....	3
106	Control of Materials .....	5
107	Legal Regulations and Responsibility to Public .....	6
108	Prosecution and Progress .....	14
109	Measurement and Payment .....	15
202	Earth and Rock Excavation .....	17
211	Topsoil and Compost .....	19
250	Seeding .....	20
253	Planting Woody Plants .....	21
280	Temporary Erosion and Sediment Control .....	23
312	Stabilized Subbase .....	24
406	Hot-Mix Asphalt Binder and Surface Course .....	25
407	Hot-Mix Asphalt Pavement (Full-Depth) .....	28
420	Portland Cement Concrete Pavement .....	32
424	Portland Cement Concrete Sidewalk .....	34
440	Removal of Existing Pavement and Appurtenances .....	35
502	Excavation for Structures .....	36
503	Concrete Structures .....	37
504	Precast Concrete Structures .....	40
506	Cleaning and Painting New Steel Structures .....	41
512	Piling .....	42
516	Drilled Shafts .....	43
521	Bearings .....	44
540	Box Culverts .....	45
588	Bridge Relief Joint System .....	46
589	Elastic Joint Sealer .....	48
602	Catch Basin, Manhole, Inlet, Drainage Structure, and Valve Vault Construction, Adjustment, and Reconstruction .....	49
603	Adjusting Frames and Grates of Drainage and Utility Structures .....	50
606	Concrete Gutter, Curb, Median, and Paved Ditch .....	52
610	Shoulder Inlets with Curb .....	53
639	Precast Prestressed Concrete Sight Screen .....	54
642	Shoulder Rumble Strips .....	55

643	Impact Attenuators .....	56
644	High Tension Cable Median Barrier .....	58
669	Removal and Disposal of Regulated Substances .....	60
670	Engineer's Field Office and Laboratory .....	64
701	Work Zone Traffic Control and Protection .....	65
706	Impact Attenuators, Temporary .....	68
707	Movable Traffic Barrier .....	71
708	Temporary Water Filled Barrier .....	73
730	Wood Sign Support .....	75
780	Pavement Striping .....	76
816	Unit Duct .....	81
836	Pole Foundation .....	82
860	Master Controller .....	83
1001	Cement .....	84
1003	Fine Aggregates .....	85
1004	Coarse Aggregates .....	87
1006	Metals .....	91
1011	Mineral Filler .....	93
1017	Packaged, Dry, Combined Materials for Mortar .....	94
1018	Packaged Rapid Hardening Mortar or Concrete .....	95
1019	Controlled Low-Strength Material (CLSM).....	96
1020	Portland Cement Concrete .....	97
1024	Grout and Nonshrink Grout .....	136
1030	Hot-Mix Asphalt .....	137
1040	Drain Pipe, Tile, Drainage Mat, and Wall Drain .....	142
1042	Precast Concrete Products .....	143
1069	Pole and Tower .....	144
1070	Foundation and Breakaway Devices .....	145
1073	Controller .....	146
1081	Materials for Planting .....	147
1082	Preformed Bearing Pads .....	148
1083	Elastomeric Bearings .....	149
1088	Wireway and Conduit System .....	150
1095	Pavement Markings .....	152
1101	General Equipment .....	155
1102	Hot-Mix Asphalt Equipment .....	157
1103	Portland Cement Concrete Equipment .....	159
1105	Pavement Marking Equipment .....	160
1106	Work Zone Traffic Control Devices .....	161

CHECK SHEET  
FOR  
RECURRING SPECIAL PROVISIONS

Adopted January 1, 2015

The following RECURRING SPECIAL PROVISIONS indicated by an "X" are applicable to this contract and are included by reference:

<u>CHECK SHEET #</u>	<u>RECURRING SPECIAL PROVISIONS</u>	<u>PAGE NO.</u>
1	<input type="checkbox"/> Additional State Requirements for Federal-Aid Construction Contracts	163
2	<input type="checkbox"/> Subletting of Contracts (Federal-Aid Contracts)	166
3	<input type="checkbox"/> EEO	167
4	<input type="checkbox"/> Specific EEO Responsibilities Non Federal-Aid Contracts	177
5	<input type="checkbox"/> Required Provisions - State Contracts	182
6	<input type="checkbox"/> Asbestos Bearing Pad Removal	188
7	<input type="checkbox"/> Asbestos Waterproofing Membrane and Asbestos Hot-Mix Asphalt Surface Removal	189
8	<input type="checkbox"/> Temporary Stream Crossings and In-Stream Work Pads	190
9	<input type="checkbox"/> Construction Layout Stakes Except for Bridges	191
10	<input type="checkbox"/> Construction Layout Stakes	194
11	<input type="checkbox"/> Use of Geotextile Fabric for Railroad Crossing	197
12	<input type="checkbox"/> Subsealing of Concrete Pavements	199
13	<input type="checkbox"/> Hot-Mix Asphalt Surface Correction	203
14	<input type="checkbox"/> Pavement and Shoulder Resurfacing	205
15	Reserved	206
16	<input type="checkbox"/> Patching with Hot-Mix Asphalt Overlay Removal	207
17	<input type="checkbox"/> Polymer Concrete	208
18	<input type="checkbox"/> PVC Pipeliner	210
19	<input type="checkbox"/> Pipe Underdrains	211
20	<input type="checkbox"/> Guardrail and Barrier Wall Delineation	212
21	<input type="checkbox"/> Bicycle Racks	216
22	Reserved	218
23	<input type="checkbox"/> Temporary Portable Bridge Traffic Signals	219
24	<input type="checkbox"/> Work Zone Public Information Signs	221
25	<input type="checkbox"/> Nighttime Inspection of Roadway Lighting	222
26	<input type="checkbox"/> English Substitution of Metric Bolts	223
27	<input type="checkbox"/> English Substitution of Metric Reinforcement Bars	224
28	<input type="checkbox"/> Calcium Chloride Accelerator for Portland Cement Concrete	225
29	Reserved	226
30	<input checked="" type="checkbox"/> Quality Control of Concrete Mixtures at the Plant	227
31	<input checked="" type="checkbox"/> Quality Control/Quality Assurance of Concrete Mixtures	235
32	<input type="checkbox"/> Digital Terrain Modeling for Earthwork Calculations	251
33	<input type="checkbox"/> Pavement Marking Removal	253
34	<input checked="" type="checkbox"/> Preventive Maintenance – Bituminous Surface Treatment	254
35	<input checked="" type="checkbox"/> Preventive Maintenance – Cape Seal	260
36	<input type="checkbox"/> Preventive Maintenance – Micro-Surfacing	275
37	<input checked="" type="checkbox"/> Preventive Maintenance – Slurry Seal	286
38	<input checked="" type="checkbox"/> Temporary Raised Pavement Markers	296
39	<input type="checkbox"/> Restoring Bridge Approach Pavements Using High-Density Foam	297

NOT FOR BID

CHECK SHEET  
FOR  
LOCAL ROADS AND STREETS RECURRING SPECIAL PROVISIONS

Adopted January 1, 2015

The following LOCAL ROADS AND STREETS RECURRING SPECIAL PROVISIONS indicated by an "X" are applicable to this contract and are included by reference:

LOCAL ROADS AND STREETS RECURRING SPECIAL PROVISIONS

<u>CHECK SHEET #</u>		<u>PAGE NO.</u>
LRS 1	Reserved.....	301
LRS 2	<input type="checkbox"/> Furnished Excavation .....	302
LRS 3	<input checked="" type="checkbox"/> Work Zone Traffic Control Surveillance .....	303
LRS 4	<input checked="" type="checkbox"/> Flaggers in Work Zones .....	304
LRS 5	<input checked="" type="checkbox"/> Contract Claims .....	305
LRS 6	<input checked="" type="checkbox"/> Bidding Requirements and Conditions for Contract Proposals .....	306
LRS 7	<input type="checkbox"/> Bidding Requirements and Conditions for Material Proposals .....	312
LRS 8	Reserved.....	318
LRS 9	<input type="checkbox"/> Bituminous Surface Treatments .....	319
LRS 10	Reserved.....	320
LRS 11	<input checked="" type="checkbox"/> Employment Practices .....	321
LRS 12	<input checked="" type="checkbox"/> Wages of Employees on Public Works .....	323
LRS 13	<input checked="" type="checkbox"/> Selection of Labor .....	325
LRS 14	<input type="checkbox"/> Paving Brick and Concrete Paver Pavements and Sidewalks .....	326
LRS 15	<input checked="" type="checkbox"/> Partial Payments .....	329
LRS 16	<input checked="" type="checkbox"/> Protests on Local Lettings .....	330
LRS 17	<input checked="" type="checkbox"/> Substance Abuse Prevention Program .....	331
LRS 18	<input type="checkbox"/> Multigrade Cold Mix Asphalt .....	332

NOT FOR BIDDING

NOT FOR BID

BDE SPECIAL PROVISIONS  
For the April 24 and June 12, 2015 Lettings

The following special provisions indicated by an "x" are applicable to this contract and will be included by the Project Development and Implementation Section of the BD&E. An \* indicates a new or revised special provision for the letting.

<u>File Name</u>	<u>#</u>	<u>Special Provision Title</u>	<u>Effective</u>	<u>Revised</u>
80240	1	Above Grade Inlet Protection	July 1, 2009	Jan. 1, 2012
80099	2	Accessible Pedestrian Signals (APS)	April 1, 2003	Jan. 1, 2014
80274	3	Aggregate Subgrade Improvement	April 1, 2012	Jan. 1, 2013
80192	4	Automated Flagger Assistance Device	Jan. 1, 2008	
80173	5	Bituminous Materials Cost Adjustments	Nov. 2, 2006	Aug. 1, 2013
80241	6	Bridge Demolition Debris	July 1, 2009	
5026I	7	Building Removal-Case I (Non-Friable and Friable Asbestos)	Sept. 1, 1990	April 1, 2010
5048I	8	Building Removal-Case II (Non-Friable Asbestos)	Sept. 1, 1990	April 1, 2010
5049I	9	Building Removal-Case III (Friable Asbestos)	Sept. 1, 1990	April 1, 2010
5053I	10	Building Removal-Case IV (No Asbestos)	Sept. 1, 1990	April 1, 2010
80310	11	Coated Galvanized Steel Conduit	Jan. 1, 2013	Jan. 1, 2015
80341	12	Coilable Nonmetallic Conduit	Aug. 1, 2014	Jan. 1, 2015
80198	13	Completion Date (via calendar days)	April 1, 2008	
80199	14	Completion Date (via calendar days) Plus Working Days	April 1, 2008	
* 80293	15	Concrete Box Culverts with Skews > 30 Degrees and Design Fills ≤ 5 Feet	April 1, 2012	April 1, 2015
80294	16	Concrete Box Culverts with Skews ≤ 30 Degrees Regardless of Design Fill and Skews > 30 Degrees with Design Fills > 5 Feet	April 1, 2012	April 1, 2014
80311	17	Concrete End Sections for Pipe Culverts	Jan. 1, 2013	
80334	18	✓ Concrete Gutter, Curb, Median, and Paved Ditch	April 1, 2014	Aug. 1, 2014
80277	19	Concrete Mix Design – Department Provided	Jan. 1, 2012	Jan. 1, 2014
80261	20	✓ Construction Air Quality – Diesel Retrofit	June 1, 2010	Nov. 1, 2014
80335	21	Contract Claims	April 1, 2014	
* 80029	22	Disadvantaged Business Enterprise Participation	Sept. 1, 2000	Jan. 2, 2015
* 80358	23	Equal Employment Opportunity	April 1, 2015	
80265	24	✓ Friction Aggregate	Jan. 1, 2011	Nov. 1, 2014
80229	25	Fuel Cost Adjustment	April 1, 2009	July 1, 2009
80329	26	Glare Screen	Jan. 1, 2014	
80304	27	Grooving for Recessed Pavement Markings	Nov. 1, 2012	Aug. 1, 2014
80246	28	✓ Hot-Mix Asphalt – Density Testing of Longitudinal Joints	Jan. 1, 2010	April 1, 2012
80322	29	✓ Hot-Mix Asphalt – Mixture Design Composition and Volumetric Requirements	Nov. 1, 2013	Nov. 1, 2014
80323	30	✓ Hot-Mix Asphalt – Mixture Design Verification and Production	Nov. 1, 2013	Nov. 1, 2014
* 80347	31	Hot-Mix Asphalt – Pay for Performance Using Percent Within Limits – Jobsite Sampling	Nov. 1, 2014	April 1, 2015
80348	32	✓ Hot-Mix Asphalt – Prime Coat	Nov. 1, 2014	
80315	33	Insertion Lining of Culverts	Jan. 1, 2013	Nov. 1, 2013
80351	34	Light Tower	Jan. 1, 2015	
80336	35	Longitudinal Joint and Crack Patching	April 1, 2014	
* 80324	36	LRFD Pipe Culvert Burial Tables	Nov. 1, 2013	April 1, 2015
* 80325	37	LRFD Storm Sewer Burial Tables	Nov. 1, 2013	April 1, 2015
80045	38	Material Transfer Device	June 15, 1999	Aug. 1, 2014
80342	39	Mechanical Side Tie Bar Inserter	Aug. 1, 2014	Jan. 1, 2015
80165	40	Moisture Cured Urethane Paint System	Nov. 1, 2006	Jan. 1, 2010
80337	41	Paved Shoulder Removal	April 1, 2014	
80349	42	Pavement Marking Blackout Tape	Nov. 1, 2014	
80298	43	Pavement Marking Tape Type IV	April 1, 2012	

<u>File Name</u>	<u>#</u>		<u>Special Provision Title</u>	<u>Effective</u>	<u>Revised</u>
80254	44	<input checked="" type="checkbox"/>	Pavement Patching	Jan. 1, 2010	
80352	45	<input type="checkbox"/>	Pavement Striping - Symbols	Jan. 1, 2015	
* 80359	46	<input type="checkbox"/>	Portland Cement Concrete Bridge Deck Curing	April 1, 2015	
* 80353	47	<input type="checkbox"/>	Portland Cement Concrete Inlay or Overlay	Jan. 1, 2015	April 1, 2015
80338	48	<input type="checkbox"/>	Portland Cement Concrete Partial Depth Hot-Mix Asphalt Patching	April 1, 2014	
80343	49	<input type="checkbox"/>	Precast Concrete Handhole	Aug. 1, 2014	
80300	50	<input type="checkbox"/>	Preformed Plastic Pavement Marking Type D - Inlaid	April 1, 2012	
80328	51	<input type="checkbox"/>	Progress Payments	Nov. 2, 2013	
3426I	52	<input type="checkbox"/>	Railroad Protective Liability Insurance	Dec. 1, 1986	Jan. 1, 2006
80157	53	<input type="checkbox"/>	Railroad Protective Liability Insurance (5 and 10)	Jan. 1, 2006	
80306	54	<input type="checkbox"/>	Reclaimed Asphalt Pavement (RAP) and Reclaimed Asphalt Shingles (RAS)	Nov. 1, 2012	April 1, 2014
80350	55	<input type="checkbox"/>	Retroreflective Sheeting for Highway Signs	Nov. 1, 2014	
80327	56	<input type="checkbox"/>	Reinforcement Bars	Nov. 1, 2013	
80344	57	<input type="checkbox"/>	Rigid Metal Conduit	Aug. 1, 2014	
* 80354	58	<input type="checkbox"/>	Sidewalk, Corner, or Crosswalk Closure	Jan. 1, 2015	April 1, 2015
80340	59	<input type="checkbox"/>	Speed Display Trailer	April 2, 2014	
80127	60	<input type="checkbox"/>	Steel Cost Adjustment	April 2, 2004	April 1, 2009
80317	61	<input type="checkbox"/>	Surface Testing of Hot-Mix Asphalt Overlays	Jan. 1, 2013	
80355	62	<input type="checkbox"/>	Temporary Concrete Barrier	Jan. 1, 2015	
80301	63	<input type="checkbox"/>	Tracking the Use of Pesticides	Aug. 1, 2012	
80356	64	<input type="checkbox"/>	Traffic Barrier Terminals Type 6 or 6B	Jan. 1, 2015	
20338	65	<input type="checkbox"/>	Training Special Provisions	Oct. 15, 1975	
80318	66	<input type="checkbox"/>	Traversable Pipe Grate	Jan. 1, 2013	April 1, 2014
* 80345	67	<input type="checkbox"/>	Underpass Luminaire	Aug. 1, 2014	April 1, 2015
80357	68	<input type="checkbox"/>	Urban Half Road Closure with Mountable Median	Jan. 1, 2015	
* 80346	69	<input type="checkbox"/>	Waterway Obstruction Warning Luminaire	Aug. 1, 2014	April 1, 2015
80288	70	<input checked="" type="checkbox"/>	Warm Mix Asphalt	Jan. 1, 2012	Nov. 1, 2014
80302	71	<input type="checkbox"/>	Weekly DBE Trucking Reports	June 2, 2012	
80289	72	<input type="checkbox"/>	Wet Reflective Thermoplastic Pavement Marking	Jan. 1, 2012	
80071	73	<input type="checkbox"/>	Working Days	Jan. 1, 2002	

The following special provisions are in the 2015 Supplemental Specifications and Recurring Special Provisions:

<u>File Name</u>	<u>Special Provision Title</u>	<u>New Location</u>	<u>Effective</u>	<u>Revised</u>
80292	Coarse Aggregate in Bridge Approach Slabs/Footings	Articles 1004.01(b) and 1004.02(f)	April 1, 2012	April 1, 2013
80303	Granular Materials	Articles 1003.04, 1003.04(c), and 1004.05(c)	Nov. 1, 2012	
80330	Pavement Marking for Bike Symbol	Article 780.14	Jan. 1, 2014	
80331	Payrolls and Payroll Records	Recurring CS #1 and #5	Jan. 1, 2014	
80332	Portland Cement Concrete – Curing of Abutments and Piers	Article 1020.13	Jan. 1, 2014	
80326	Portland Cement Concrete Equipment	Article 1103.03(a)(5)	Nov. 1, 2013	
80281	Quality Control/Quality Assurance of Concrete Mixtures	Recurring CS #31	Jan. 1, 2012	Jan. 1, 2014
80283	Removal and Disposal of Regulated Substances	Articles 669.01, 669.08, 669.09, 669.14, and 669.16	Jan. 1, 2012	Nov. 2, 2012
80319	Removal and Disposal of Surplus Materials	Article 202.03	Nov. 2, 2012	
80307	Seeding	Article 250.07	Nov. 1, 2012	
80339	Stabilized Subbase	Article 312.06	April 1, 2014	
80333	Traffic Control Setup and Removal Freeway/Expressway	Articles 701.18(l) and 701.19(a)	Jan. 1, 2014	

The following special provisions require additional information from the designer. The additional information needs to be included in a separate document attached to this check sheet. The Project Development and Implementation section will then include the information in the applicable special provision. The Special Provisions are:

- Bridge Demolition Debris
- Building Removal-Case I
- Building Removal-Case II
- Building Removal-Case III
- Building Removal-Case IV
- Completion Date
- Completion Date Plus Working Days
- DBE Participation
- Material Transfer Device
- Railroad Protective Liability Insurance
- Training Special Provisions
- Working Days

NOT FOR BID

NOT FOR BID

**CONCRETE GUTTER, CURB, MEDIAN, AND PAVED DITCH (BDE)**

Effective: April 1, 2014

Revised: August 1, 2014

Add the following to Article 606.02 of the Standard Specifications:

“(i) Polyurethane Joint Sealant ..... 1050.04”

Revise the fifth paragraph of Article 606.07 of the Standard Specifications to read:

“Transverse contraction and longitudinal construction joints shall be sealed according to Article 420.12, except transverse joints in concrete curb and gutter shall be sealed with polysulfide or polyurethane joint sealant.”

Add the following to Section 1050 of the Standard Specifications:

“**1050.04 Polyurethane Joint Sealant.** The joint sealant shall be a polyurethane sealant, Type S, Grade NS, Class 25 or better, Use T (T<sub>1</sub> or T<sub>2</sub>), according to ASTM C 920.”

80334

## CONSTRUCTION AIR QUALITY – DIESEL RETROFIT (BDE)

Effective: June 1, 2010

Revised: November 1, 2014

The reduction of emissions of particulate matter (PM) for off-road equipment shall be accomplished by installing retrofit emission control devices. The term “equipment” refers to diesel fuel powered devices rated at 50 hp and above, to be used on the jobsite in excess of seven calendar days over the course of the construction period on the jobsite (including rental equipment).

Contractor and subcontractor diesel powered off-road equipment assigned to the contract shall be retrofitted using the phased in approach shown below. Equipment that is of a model year older than the year given for that equipment’s respective horsepower range shall be retrofitted:

Effective Dates	Horsepower Range	Model Year
June 1, 2010 <sup>1/</sup>	600-749	2002
	750 and up	2006
June 1, 2011 <sup>2/</sup>	100-299	2003
	300-599	2001
	600-749	2002
	750 and up	2006
June 1, 2012 <sup>2/</sup>	50-99	2004
	100-299	2003
	300-599	2001
	600-749	2002
	750 and up	2006

1/ Effective dates apply to Contractor diesel powered off-road equipment assigned to the contract.

2/ Effective dates apply to Contractor and subcontractor diesel powered off-road equipment assigned to the contract.

The retrofit emission control devices shall achieve a minimum PM emission reduction of 50 percent and shall be:

- a) Included on the U.S. Environmental Protection Agency (USEPA) *Verified Retrofit Technology List* (<http://www.epa.gov/cleandiesel/verification/verif-list.htm>), or verified by the California Air Resources Board (CARB) (<http://www.arb.ca.gov/diesel/verdev/vt/cvt.htm>); or
- b) Retrofitted with a non-verified diesel retrofit emission control device if verified retrofit emission control devices are not available for equipment proposed to be used on the project, and if the Contractor has obtained a performance certification from the retrofit

device manufacturer that the emission control device provides a minimum PM emission reduction of 50 percent.

Note: Large cranes (Crawler mounted cranes) which are responsible for critical lift operations are exempt from installing retrofit emission control devices if such devices adversely affect equipment operation.

Diesel powered off-road equipment with engine ratings of 50 hp and above, which are unable to be retrofitted with verified emission control devices or if performance certifications are not available which will achieve a minimum 50 percent PM reduction, may be granted a waiver by the Department if documentation is provided showing good faith efforts were made by the Contractor to retrofit the equipment.

Construction shall not proceed until the Contractor submits a certified list of the diesel powered off-road equipment that will be used, and as necessary, retrofitted with emission control devices. The list(s) shall include (1) the equipment number, type, make, Contractor/rental company name; and (2) the emission control devices make, model, USEPA or CARB verification number, or performance certification from the retrofit device manufacturer. Equipment reported as fitted with emissions control devices shall be made available to the Engineer for visual inspection of the device installation, prior to being used on the jobsite.

The Contractor shall submit an updated list of retrofitted off-road construction equipment as retrofitted equipment changes or comes on to the jobsite. The addition or deletion of any diesel powered equipment shall be included on the updated list.

If any diesel powered off-road equipment is found to be in non-compliance with any portion of this special provision, the Engineer will issue the Contractor a diesel retrofit deficiency deduction.

Any costs associated with retrofitting any diesel powered off-road equipment with emission control devices shall be considered as included in the contract unit prices bid for the various items of work involved and no additional compensation will be allowed. The Contractor's compliance with this notice and any associated regulations shall not be grounds for a claim.

### **Diesel Retrofit Deficiency Deduction**

When the Engineer determines that a diesel retrofit deficiency exists, a daily monetary deduction will be imposed for each calendar day or fraction thereof the deficiency continues to exist. The calendar day(s) will begin when the time period for correction is exceeded and end with the Engineer's written acceptance of the correction. The daily monetary deduction will be \$1,000.00 for each deficiency identified.

The deficiency will be based on lack of diesel retrofit emissions control.

If a Contractor accumulates three diesel retrofit deficiency deductions for the same piece of equipment in a contract period, the Contractor will be shutdown until the deficiency is corrected.

Such a shutdown will not be grounds for any extension of the contract time, waiver of penalties, or be grounds for any claim.

80261

NOT FOR BID

## FRICITION AGGREGATE (BDE)

Effective: January 1, 2011

Revised: November 1, 2014

Revise Article 1004.01(a)(4) of the Standard Specifications to read:

- “(4) Crushed Stone. Crushed stone shall be the angular fragments resulting from crushing undisturbed, consolidated deposits of rock by mechanical means. Crushed stone shall be divided into the following, when specified.
- a. Carbonate Crushed Stone. Carbonate crushed stone shall be either dolomite or limestone. Dolomite shall contain 11.0 percent or more magnesium oxide (MgO). Limestone shall contain less than 11.0 percent magnesium oxide (MgO).
  - b. Crystalline Crushed Stone. Crystalline crushed stone shall be either metamorphic or igneous stone, including but is not limited to, quartzite, granite, rhyolite and diabase.”

Revise Article 1004.03(a) of the Standard Specifications to read:

“**1004.03 Coarse Aggregate for Hot-Mix Asphalt (HMA).** The aggregate shall be according to Article 1004.01 and the following.

(a) Description. The coarse aggregate for HMA shall be according to the following table.

Use	Mixture	Aggregates Allowed
Class A	Seal or Cover	<u>Allowed Alone or in Combination</u> <sup>5/</sup> : Gravel Crushed Gravel Carbonate Crushed Stone Crystalline Crushed Stone Crushed Sandstone Crushed Slag (ACBF) Crushed Steel Slag Crushed Concrete

Use	Mixture	Aggregates Allowed		
HMA Low ESAL	Stabilized Subbase or Shoulders	<u>Allowed Alone or in Combination</u> <sup>5/</sup> : Gravel Crushed Gravel Carbonate Crushed Stone Crystalline Crushed Stone Crushed Sandstone Crushed Slag (ACBF) Crushed Steel Slag <sup>1/</sup> Crushed Concrete		
HMA High ESAL Low ESAL	Binder IL-19.0 or IL-19.0L  SMA Binder	<u>Allowed Alone or in Combination</u> <sup>5/</sup> : Crushed Gravel Carbonate Crushed Stone <sup>2/</sup> Crystalline Crushed Stone Crushed Sandstone Crushed Slag (ACBF) Crushed Concrete <sup>3/</sup>		
HMA High ESAL Low ESAL	C Surface and Leveling Binder IL-9.5 or IL-9.5L  SMA Ndesign 50 Surface	<u>Allowed Alone or in Combination</u> <sup>5/</sup> : Crushed Gravel Carbonate Crushed Stone <sup>2/</sup> Crystalline Crushed Stone Crushed Sandstone Crushed Slag (ACBF) Crushed Steel Slag <sup>4/</sup> Crushed Concrete <sup>3/</sup>		
HMA High ESAL	D Surface and Leveling Binder IL-9.5  SMA Ndesign 50 Surface	<u>Allowed Alone or in Combination</u> <sup>5/</sup> : Crushed Gravel Carbonate Crushed Stone (other than Limestone) <sup>2/</sup> Crystalline Crushed Stone Crushed Sandstone Crushed Slag (ACBF) Crushed Steel Slag <sup>4/</sup> Crushed Concrete <sup>3/</sup>		
		<u>Other Combinations Allowed:</u>		
		<table border="1"> <tr> <td><i>Up to...</i></td> <td><i>With...</i></td> </tr> <tr> <td>25% Limestone</td> <td>Dolomite</td> </tr> </table>	<i>Up to...</i>	<i>With...</i>
<i>Up to...</i>	<i>With...</i>			
25% Limestone	Dolomite			

Use	Mixture	Aggregates Allowed			
		50% Limestone	Any Mixture D aggregate other than Dolomite		
		75% Limestone	Crushed Slag (ACBF) or Crushed Sandstone		
HMA High ESAL	E Surface IL-9.5  SMA Ndesign 80 Surface	<u>Allowed Alone or in Combination</u> <sup>5/</sup> : Crushed Gravel Crystalline Crushed Stone Crushed Sandstone Crushed Slag (ACBF) Crushed Steel Slag Crushed Concrete <sup>3/</sup>  No Limestone.			
		<u>Other Combinations Allowed:</u> <table border="1" data-bbox="703 1052 1297 1094"> <tr> <td data-bbox="703 1052 1013 1094"><i>Up to...</i></td> <td data-bbox="1013 1052 1297 1094"><i>With...</i></td> </tr> </table>		<i>Up to...</i>	<i>With...</i>
<i>Up to...</i>	<i>With...</i>				
		50% Dolomite <sup>2/</sup>	Any Mixture E aggregate		
		75% Dolomite <sup>2/</sup>	Crushed Sandstone, Crushed Slag (ACBF), Crushed Steel Slag, or Crystalline Crushed Stone		
		75% Crushed Gravel or Crushed Concrete <sup>3/</sup>	Crushed Sandstone, Crystalline Crushed Stone, Crushed Slag (ACBF), or Crushed Steel Slag		
HMA High ESAL	F Surface IL-9.5  SMA Ndesign 80 Surface	<u>Allowed Alone or in Combination</u> <sup>5/</sup> : Crystalline Crushed Stone Crushed Sandstone Crushed Slag (ACBF) Crushed Steel Slag No Limestone.			
		<u>Other Combinations Allowed:</u>			

Use	Mixture	Aggregates Allowed	
		<i>Up to...</i>	<i>With...</i>
		50% Crushed Gravel, Crushed Concrete <sup>3/</sup> , or Dolomite <sup>2/</sup>	Crushed Sandstone, Crushed Slag (ACBF), Crushed Steel Slag, or Crystalline Crushed Stone

- 1/ Crushed steel slag allowed in shoulder surface only.
- 2/ Carbonate crushed stone shall not be used in SMA Ndesign 80. In SMA Ndesign 50, carbonate crushed stone shall not be blended with any of the other aggregates allowed alone in Ndesign 50 SMA binder or Ndesign 50 SMA surface.
- 3/ Crushed concrete will not be permitted in SMA mixes.
- 4/ Crushed steel slag shall not be used as leveling binder.
- 5/ When combinations of aggregates are used, the blend percent measurements shall be by volume."

80265

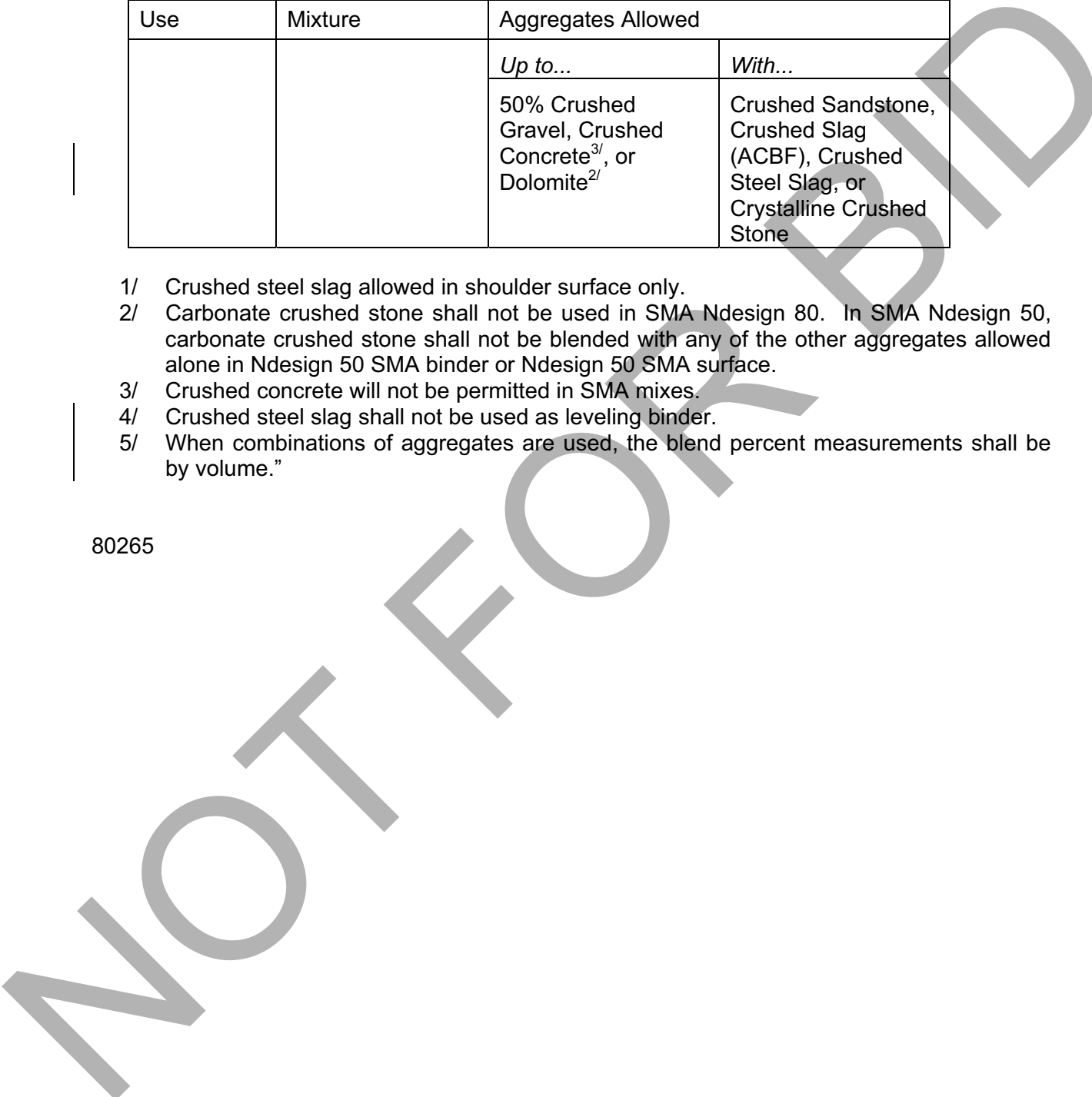

## HOT-MIX ASPHALT - DENSITY TESTING OF LONGITUDINAL JOINTS (BDE)

Effective: January 1, 2010

Revised: April 1, 2012

Description. This work shall consist of testing the density of longitudinal joints as part of the quality control/quality assurance (QC/QA) of hot-mix asphalt (HMA). Work shall be according to Section 1030 of the Standard Specifications except as follows.

Quality Control/Quality Assurance (QC/QA). Delete the second and third sentence of the third paragraph of Article 1030.05(d)(3) of the Standard Specifications.

Add the following paragraphs to the end of Article 1030.05(d)(3) of the Standard Specifications:

“Longitudinal joint density testing shall be performed at each random density test location. Longitudinal joint testing shall be located at a distance equal to the lift thickness or a minimum of 4 in. (100 mm), from each pavement edge. (i.e. for a 5 in. (125 mm) lift the near edge of the density gauge or core barrel shall be within 5 in. (125 mm) from the edge of pavement.) Longitudinal joint density testing shall be performed using either a correlated nuclear gauge or cores.

- a. Confined Edge. Each confined edge density shall be represented by a one-minute nuclear density reading or a core density and shall be included in the average of density readings or core densities taken across the mat which represents the Individual Test.
- b. Unconfined Edge. Each unconfined edge joint density shall be represented by an average of three one-minute density readings or a single core density at the given density test location and shall meet the density requirements specified herein. The three one-minute readings shall be spaced ten feet apart longitudinally along the unconfined pavement edge and centered at the random density test location.”

Revise the Density Control Limits table in Article 1030.05(d)(4) of the Standard Specifications to read:

“Mixture Composition	Parameter	Individual Test (includes confined edges)	Unconfined Edge Joint Density Minimum
IL-4.75	Ndesign = 50	93.0 – 97.4%	91.0%
IL-9.5, IL-12.5	Ndesign ≥ 90	92.0 – 96.0%	90.0%
IL-9.5, IL-9.5L, IL-12.5	Ndesign < 90	92.5 – 97.4%	90.0%
IL-19.0, IL-25.0	Ndesign ≥ 90	93.0 – 96.0%	90.0%
IL-19.0, IL-19.0L, IL-25.0	Ndesign < 90	93.0 – 97.4%	90.0%

SMA	Ndesign = 50 & 80	93.5 – 97.4%	91.0%
All Other	Ndesign = 30	93.0 - 97.4%	90.0%”

80246

NOT FOR BID

## HOT-MIX ASPHALT – MIXTURE DESIGN COMPOSITION AND VOLUMETRIC REQUIREMENTS (BDE)

Effective: November 1, 2013

Revised: November 1, 2014

Revise the last sentence of the first paragraph of Article 312.05 of the Standard Specifications to read:

“The minimum compacted thickness of each lift shall be according to Article 406.06(d).”

Delete the minimum compacted lift thickness table in Article 312.05 of the Standard Specifications.

Revise the second paragraph of Article 355.02 of the Standard Specifications to read:

“The mixture composition used shall be IL-19.0.”

Revise Article 355.05(a) of the Standard Specifications to read:

“(a) The top lift thickness shall be 2 1/4 in. (60 mm) for mixture composition IL-19.0.”

Revise the Leveling Binder table and second paragraph of Article 406.05(c) of the Standard Specifications to read:

“Leveling Binder	
Nominal, Compacted, Leveling Binder Thickness, in. (mm)	Mixture Composition
≤ 1 1/4 (32)	IL-4.75, IL-9.5, or IL-9.5L
> 1 1/4 to 2 (32 to 50)	IL-9.5 or IL-9.5L

The density requirements of Article 406.07(c) shall apply for leveling binder, machine method, when the nominal compacted thickness is: 3/4 in. (19 mm) or greater for IL-4.75 mixtures; and 1 1/4 in. (32 mm) or greater for IL-9.5 and IL-9.5L mixtures.”

Revise the table in Article 406.06(d) of the Standard Specifications to read:

“MINIMUM COMPACTED LIFT THICKNESS	
Mixture Composition	Thickness, in. (mm)
IL-4.75	3/4 (19)
IL-9.5, IL-9.5L	1 1/4 (32)
SMA-12.5	1 1/2 (38)
IL-19.0, IL-19.0L	2 1/4 (57)”

Revise the ninth paragraph of Article 406.14 of the Standard Specifications to read:

“Test strip mixture will be evaluated at the contract unit price according to the following.”

Revise Article 406.14(a) of the Standard Specifications to read:

“(a) If the HMA placed during the initial test strip is determined to be acceptable the mixture will be paid for at the contract unit price.”

Revise Article 406.14(b) of the Standard Specifications to read:

“(b) If the HMA placed during the initial test strip (1) is determined to be unacceptable to remain in place by the Engineer, and (2) was not produced within 2.0 to 6.0 percent air voids or within the individual control limits of the JMF according to the Department’s test results, the mixture will not be paid for and shall be removed at the Contractor’s expense. An additional test strip shall be constructed and the mixture will be paid for in full, if produced within 2.0 to 6.0 percent air voids and within the individual control limits of the JMF.”

Revise Article 406.14(c) of the Standard Specifications to read:

“(c) If the HMA placed during the initial test strip (1) is determined to be unacceptable to remain in place by the Engineer, and (2) was produced within 2.0 to 6.0 percent air voids and within the individual control limits of the JMF according to the Department’s test results, the mixture shall be removed. Removal will be paid according to Article 109.04. This initial mixture will be paid for at the contract unit price. An additional test strip shall be constructed and the mixture will be paid for in full, if produced within 2.0 to 6.0 percent air voids and within the individual control limits of the JMF.”

Delete Article 406.14(d) of the Standard Specifications.

Delete Article 406.14(e) of the Standard Specifications.

Delete the last sentence of Article 407.06(c) of the Standard Specifications.

Revise Note 2. of Article 442.02 of the Standard Specifications to read:

“Note 2. The mixture composition of the HMA used shall be IL-19.0 binder, designed with the same Ndesign as that specified for the mainline pavement.”

Delete the second paragraph of Article 482.02 of the Standard Specifications.

Revise the first sentence of the sixth paragraph of Article 482.05 of the Standard Specifications to read:

“When the mainline HMA binder and surface course mixture option is used on resurfacing projects, shoulder resurfacing widths of 6 ft (1.8 m) or less may be placed simultaneously with the adjacent traffic lane for both the binder and surface courses.”

Revise the second sentence of the fourth paragraph of Article 601.04 of the Standard Specifications to read:

“The top 5 in. (125 mm) of the trench shall be backfilled with an IL-19.0L Low ESAL mixture meeting the requirements of Section 1030 and compacted to a density of not less than 90 percent of the theoretical density.”

Revise the second sentence of the fifth paragraph of Article 601.04 of the Standard Specifications to read:

“The top 8 in. (200 mm) of the trench shall be backfilled with an IL-19.0L Low ESAL mixture meeting the requirements of Section 1030 and compacted to a density of not less than 90 percent of the theoretical density.”

Revise Article 1003.03(c) of the Standard Specifications to read:

“(c) Gradation. The fine aggregate gradation for all HMA shall be FA 1, FA 2, FA 20, FA 21, or FA 22. The fine aggregate gradation for SMA shall be FA/FM 20.

For mixture IL-4.75 and surface mixtures with an  $N_{design} = 90$ , at least 50 percent of the required fine aggregate fraction shall consist of either stone sand, slag sand, or steel slag meeting the FA 20 gradation.

For mixture IL-19.0,  $N_{design} = 90$  the fine aggregate fraction shall consist of at least 67 percent manufactured sand meeting FA 20 or FA 22 gradation. For mixture IL-19.0,  $N_{design} = 50$  or 70 the fine aggregate fraction shall consist of at least 50 percent manufactured sand meeting FA 20 or FA 22 gradation. The manufactured sand shall be stone sand, slag sand, steel slag sand, or combinations thereof.

Gradation FA 1, FA 2, or FA 3 shall be used when required for prime coat aggregate application for HMA.”

Remove footnote 3/ from the tables and at the end of the tables in Article 1004.01(c) of the Standard Specifications.

Delete the last sentence of the first paragraph of Article 1004.03(b) of the Standard Specifications.

Revise the table in Article 1004.03(c) of the Standard Specifications to read:

“Use	Size/Application	Gradation No.
Class A-1, 2, & 3	3/8 in. (10 mm) Seal	CA 16
Class A-1	1/2 in. (13 mm) Seal	CA 15
Class A-2 & 3	Cover	CA 14
HMA High ESAL	IL-19.0 IL-9.5	CA 11 <sup>1/</sup> CA 16 and/or CA 13 CA 16
HMA Low ESAL	IL-19.0L IL-9.5L Stabilized Subbase or Shoulders	CA 11 <sup>1/</sup> CA 16

1/ CA 16 or CA 13 may be blended with the gradations listed.”

Revise the nomenclature table in Article 1030.01 of the Standard Specifications to read:

“High ESAL	IL-19.0 binder; IL-9.5 surface
Low ESAL	IL-19.0L binder; IL-9.5L surface; Stabilized Subbase (HMA) <sup>1/</sup> ; HMA Shoulders <sup>2/</sup>

1/ Uses 19.0L binder mix.

2/ Uses 19.0L for lower lifts and 9.5L for surface lift.”

Revise Article 1030.02 of the Standard Specifications and Supplemental Specifications to read:

**“1030.02 Materials.** Materials shall be according to the following.

Item .....	Article/Section
(a) Coarse Aggregate .....	1004.03
(b) Fine Aggregate .....	1003.03
(c) RAP Material .....	1031
(d) Mineral Filler .....	1011
(e) Hydrated Lime .....	1012.01
(f) Slaked Quicklime (Note 1)	
(g) Performance Graded Asphalt Binder (Note 2) .....	1032
(h) Fibers (Note 3)	
(i) Warm Mix Asphalt (WMA) Technologies (Note 4)	

Note 1. Slaked quicklime shall be according to ASTM C 5.

Note 2. The asphalt binder shall be an SBS PG 76-28 when the SMA is used on a full-depth asphalt pavement and SBS PG 76-22 when used as an overlay.

Note 3. A stabilizing additive such as cellulose or mineral fiber shall be added to the SMA mixture according to Illinois Modified AASHTO M 325. The stabilizing additive shall meet the Fiber Quality Requirements listed in Illinois Modified AASHTO M 325. Prior to approval and use of fibers, the Contractor shall submit a notarized certification by the producer of these materials stating they meet these requirements.

Note 4. Warm mix additives or foaming processes shall be selected from the current Bureau of Materials and Physical Research Approved List, "Warm Mix Asphalt Technologies".

Revise Article 1030.04(a)(1) of the Standard Specifications and the Supplemental Specifications to read:

"(1) High ESAL Mixtures. The Job Mix Formula (JMF) shall fall within the following limits.

High ESAL, MIXTURE COMPOSITION (% PASSING) <sup>1/</sup>								
Sieve Size	IL-19.0 mm		SMA 12.5 <sup>4/</sup>		IL-9.5 mm		IL-4.75 mm	
	min	max	min	max	min	max	min	max
1 1/2 in. (37.5 mm)								
1 in. (25 mm)		100						
3/4 in. (19 mm)	90	100		100				
1/2 in. (12.5 mm)	75	89	90	99		100		100
3/8 in. (9.5 mm)			50	85	90	100		100
#4 (4.75 mm)	40	60	20	40	32	69	90	100
#8 (2.36 mm)	26	42	16	24 <sup>5/</sup>	32	52 <sup>2/</sup>	70	90
#16 (1.18 mm)	15	30			10	32	50	65
#50 (300 μm)	6	15			4	15	15	30
#100 (150 μm)	4	9			3	10	10	18
#200 (75 μm)	3	6	8.0	11.0 <sup>3/</sup>	4	6	7	9
Ratio Dust/Asphalt Binder		1.0				1.0		1.0 <sup>3/</sup>

1/ Based on percent of total aggregate weight.

2/ The mixture composition shall not exceed 44 percent passing the #8 (2.36 mm) sieve for surface courses with Ndesign = 90.

3/ Additional minus No. 200 (0.075 mm) material required by the mix design shall be mineral filler, unless otherwise approved by the Engineer.

- 4/ The maximum percent passing the #635 (20  $\mu$ m) sieve shall be  $\leq$  3 percent.
- 5/ When establishing the Adjusted Job Mix Formula (AJMF) the percent passing the #8 (2.36 mm) sieve shall not be adjusted above 24 percent.”

Delete Article 1030.04(a)(3) of the Standard Specifications.

Delete Article 1030.04(a)(4) of the Standard Specifications.

Revise the table in Article 1030.04(b)(1) of the Standard Specifications to read:

"VOLUMETRIC REQUIREMENTS High ESAL				
Ndesign	Voids in the Mineral Aggregate (VMA), % minimum			Voids Filled with Asphalt Binder (VFA), %
	IL-19.0	IL-9.5	IL-4.75 <sup>1/</sup>	
50	13.5	15.0	18.5	65 – 78 <sup>2/</sup>
70				
90				

1/ Maximum Draindown for IL-4.75 shall be 0.3 percent

2/ VFA for IL-4.75 shall be 76-83 percent”

Revise the table in Article 1030.04(b)(2) of the Standard Specifications to read:

"VOLUMETRIC REQUIREMENTS Low ESAL				
Mixture Composition	Design Compactive Effort	Design Air Voids Target %	VMA (Voids in the Mineral Aggregate), % min.	VFA (Voids Filled with Asphalt Binder), %
IL-9.5L	N <sub>DES</sub> =30	4.0	15.0	65-78
IL-19.0L	N <sub>DES</sub> =30	4.0	13.5	N/A”

Replace Article 1030.04(b)(3) of the Standard Specifications with the following:

“(3) SMA Mixtures.

ESALs (million)	Ndesign	Design Air Voids Target %	Voids in the Mineral Aggregate (VMA), % min.	Voids Filled with Asphalt (VFA), %
≤ 10	50	4.0	16.0	75 – 80
> 10	80	4.0	17.0	75 – 80”

Delete Article 1030.04(b)(4) of the Standard Specifications.

Delete Article 1030.04(b)(5) from the Supplemental Specifications.

Revise the table in Article 1030.05(d)(2)a. of the Standard Specifications to read:

"Parameter	Frequency of Tests		Test Method See Manual of Test Procedures for Materials
	High ESAL Mixture	Low ESAL Mixture	
Aggregate Gradation  % passing sieves: 1/2 in. (12.5 mm), No. 4 (4.75 mm), No. 8 (2.36 mm), No. 30 (600 μm) No. 200 (75 μm)	1 washed ignition oven test on the mix per half day of production	Note 3.	Illinois Procedure
Asphalt Binder Content by Ignition Oven  Note 1.	1 per half day of production		Illinois-Modified AASHTO T 308
VMA  Note 2.	Day's production ≥ 1200 tons:  1 per half day of production		Illinois-Modified AASHTO R 35
	Day's production < 1200 tons:  1 per half day of production for first 2 days and 1 per day thereafter (first sample of the day)		

"Parameter	Frequency of Tests		Test Method See Manual of Test Procedures for Materials
	High ESAL Mixture	Low ESAL Mixture	
Air Voids  Bulk Specific Gravity of Gyratory Sample  Note 4.	Day's production ≥ 1200 tons:	1 per half day of production	Illinois-Modified AASHTO T 312
	Day's production < 1200 tons:		
Maximum Specific Gravity of Mixture	Day's production ≥ 1200 tons:	1 per half day of production	Illinois-Modified AASHTO T 209
	Day's production < 1200 tons:		
	1 per half day of production for first 2 days and 1 per day thereafter (first sample of the day)		

Note 1. The Engineer may waive the ignition oven requirement for asphalt binder content if the aggregates to be used are known to have ignition asphalt binder content calibration factors which exceed 1.5 percent. If the ignition oven requirement is waived, other Department approved methods shall be used to determine the asphalt binder content.

Note 2. The  $G_{sb}$  used in the voids in the mineral aggregate (VMA) calculation shall be the same average  $G_{sb}$  value listed in the mix design.

Note 3. The Engineer reserves the right to require additional hot bin gradations for batch plants if control problems are evident.

Note 4. The WMA compaction temperature for mixture volumetric testing shall be  $270 \pm 5$  °F ( $132 \pm 3$  °C) for quality control testing. The WMA compaction temperature for quality assurance testing will be  $270 \pm 5$  °F ( $132 \pm 3$  °C) if the mixture is not allowed to cool to room temperature. If the mixture is allowed to cool to room temperature, it shall be reheated to standard HMA compaction temperatures."

Revise the table in Article 1030.05(d)(2)b. of the Standard Specifications to read:

“Parameter	High ESAL Mixture Low ESAL Mixture
Ratio Dust/Asphalt Binder	0.6 to 1.2
Moisture	0.3 %”

Revise the Article 1030.05(d)(4) of the Supplemental Specifications to read:

“(4) Control Limits. Target values shall be determined by applying adjustment factors to the AJMF where applicable. The target values shall be plotted on the control charts within the following control limits.

CONTROL LIMITS						
Parameter	High ESAL Low ESAL		SMA		IL-4.75	
	Individual Test	Moving Avg. of 4	Individual Test	Moving Avg. of 4	Individual Test	Moving Avg. of 4
% Passing: <sup>1/</sup>						
1/2 in. (12.5 mm)	± 6 %	± 4 %	± 6 %	± 4 %		
3/8 in. (9.5mm)			± 4 %	± 3 %		
No. 4 (4.75 mm)	± 5 %	± 4 %	± 5 %	± 4 %		
No. 8 (2.36 mm)	± 5 %	± 3 %	± 4 %	± 2 %		
No. 16 (1.18 mm)			± 4 %	± 2 %	± 4 %	± 3 %
No. 30 (600 µm)	± 4 %	± 2.5 %	± 4 %	± 2.5 %		
Total Dust Content No. 200 (75 µm)	± 1.5 %	± 1.0 %			± 1.5 %	± 1.0 %
Asphalt Binder Content	± 0.3 %	± 0.2 %	± 0.2 %	± 0.1 %	± 0.3 %	± 0.2 %
Voids	± 1.2 %	± 1.0 %	± 1.2 %	± 1.0 %	± 1.2 %	± 1.0 %
VMA	-0.7 % <sup>2/</sup>	-0.5 % <sup>2/</sup>	-0.7 % <sup>2/</sup>	-0.5 % <sup>2/</sup>	-0.7 % <sup>2/</sup>	-0.5 % <sup>2/</sup>

1/ Based on washed ignition oven

2/ Allowable limit below minimum design VMA requirement

DENSITY CONTROL LIMITS		
Mixture Composition	Parameter	Individual Test
IL-4.75	Ndesign = 50	93.0 - 97.4 % <sup>1/</sup>
IL-9.5	Ndesign = 90	92.0 - 96.0 %
IL-9.5, IL-9.5L	Ndesign < 90	92.5 - 97.4 %
IL-19.0	Ndesign = 90	93.0 - 96.0 %
IL-19.0, IL-19.0L	Ndesign < 90	93.0 <sup>2/</sup> - 97.4 %
SMA	Ndesign = 50 & 80	93.5 - 97.4 %

1/ Density shall be determined by cores or by correlated, approved thin lift nuclear gauge.

2/ 92.0 % when placed as first lift on an unimproved subgrade.”

Revise the table in Article 1030.05(d)(5) of the Supplemental Specifications to read:

“CONTROL CHART REQUIREMENTS	High ESAL, Low ESAL, SMA & IL-4.75
Gradation <sup>1/3/</sup>	% Passing Sieves: 1/2 in. (12.5 mm) <sup>2/</sup> No. 4 (4.75 mm) No. 8 (2.36 mm) No. 30 (600 µm)
Total Dust Content <sup>1/</sup>	No. 200 (75 µm)
	Asphalt Binder Content
	Bulk Specific Gravity
	Maximum Specific Gravity of Mixture
	Voids
	Density
	VMA

1/ Based on washed ignition oven.

2/ Does not apply to IL-4.75.

3/ SMA also requires the 3/8 in. (9.5 mm) sieve.”

Delete Article 1030.05(d)(6)a.1.(b.) of the Standard Specifications.

Delete Article 1030.06(b) of the Standard Specifications.

Delete Article 1102.01(e) of the Standard Specifications.

80322

NOT FOR BID

## HOT-MIX ASPHALT – MIXTURE DESIGN VERIFICATION AND PRODUCTION (BDE)

Effective: November 1, 2013

Revised: November 1, 2014

Description. This special provision provides the requirements for Hamburg Wheel and tensile strength testing for High ESAL, IL-4.75, and Stone Matrix Asphalt (SMA) hot-mix asphalt (HMA) mixes during mix design verification and production. This special provision also provides the plant requirements for hydrated lime addition systems used in the production of High ESAL, IL-4.75, and SMA mixes.

Mix Design Testing. Add the following below the referenced AASHTO standards in Article 1030.04 of the Standard Specifications:

AASHTO T 324	Hamburg Wheel Test
AASHTO T 283	Tensile Strength Test

Add the following to Article 1030.04 of the Standard Specifications:

“(d) Verification Testing. High ESAL, IL-4.75, and SMA mix designs submitted for verification will be tested to ensure that the resulting mix designs will pass the required criteria for the Hamburg Wheel Test (Illinois Modified AASHTO T 324) and the Tensile Strength Test (Illinois Modified AASHTO T 283). The Department will perform a verification test on gyratory specimens compacted by the Contractor. If the mix fails the Department’s verification test, the Contractor shall make necessary changes to the mix and provide passing Hamburg Wheel and tensile strength test results from a private lab. The Department will verify the passing results.

All new and renewal mix designs shall meet the following requirements for verification testing.

(1) Hamburg Wheel Test Criteria. The maximum allowable rut depth shall be 0.5 in. (12.5 mm). The minimum number of wheel passes at the 0.5 in. (12.5 mm) rut depth criteria shall be based on the high temperature binder grade of the mix as specified in the mix requirements table of the plans.

Illinois Modified AASHTO T 324 Requirements <sup>1/</sup>

PG Grade	Number of Passes
PG 58-xx (or lower)	5,000
PG 64-xx	7,500
PG 70-xx	15,000
PG 76-xx (or higher)	20,000

1/ When produced at temperatures of  $275 \pm 5$  °F ( $135 \pm 3$  °C) or less, loose Warm Mix Asphalt shall be oven aged at  $270 \pm 5$  °F ( $132 \pm 3$  °C) for two hours prior to gyratory compaction of Hamburg Wheel specimens.

(2) Tensile Strength Criteria. The minimum allowable conditioned tensile strength shall be 60 psi (415 kPa) for non-polymer modified performance graded (PG) asphalt binder and 550 kPa (80 psi) for polymer modified PG asphalt binder. The maximum allowable unconditioned tensile strength shall be 200 psi (1380 kPa).”

Production Testing. Revise Article 1030.06(a) of the Standard Specifications to read:

“(a) High ESAL, IL-4.75, WMA, and SMA Mixtures. For each contract, a 300 ton (275 metric tons) test strip will be required at the beginning of HMA production for each mixture with a quantity of 3000 tons (2750 metric tons) or more according to the Manual of Test Procedures for Materials “Hot Mix Asphalt Test Strip Procedures”.

Before start-up, target values shall be determined by applying gradation correction factors to the JMF when applicable. These correction factors shall be determined from previous experience. The target values, when approved by the Engineer, shall be used to control HMA production. Plant settings and control charts shall be set according to target values.

Before constructing the test strip, target values shall be determined by applying gradation correction factors to the JMF when applicable. After any JMF adjustment, the JMF shall become the Adjusted Job Mix Formula (AJMF). Upon completion of the first acceptable test strip, the JMF shall become the AJMF regardless of whether or not the JMF has been adjusted. If an adjustment/plant change is made, the Engineer may require a new test strip to be constructed. If the HMA placed during the initial test strip is determined to be unacceptable to remain in place by the Engineer, it shall be removed and replaced.

The limitations between the JMF and AJMF are as follows.

Parameter	Adjustment
1/2 in. (12.5 mm)	$\pm 5.0$ %
No. 4 (4.75 mm)	$\pm 4.0$ %
No. 8 (2.36 mm)	$\pm 3.0$ %
No. 30 (600 $\mu$ m)	*
No. 200 (75 $\mu$ m)	*
Asphalt Binder Content	$\pm 0.3$ %

\* In no case shall the target for the amount passing be greater than the JMF.

Any adjustments outside the above limitations will require a new mix design.

Mixture sampled to represent the test strip shall include additional material sufficient for the Department to conduct Hamburg Wheel testing according to Illinois Modified AASHTO T324 (approximately 60 lb (27 kg) total).

The Contractor shall immediately cease production upon notification by the Engineer of failing Hamburg Wheel test. All prior produced material may be paved out provided all other mixture criteria is being met. No additional mixture shall be produced until the Engineer receives passing Hamburg Wheel tests.

The Department may conduct additional Hamburg Wheel tests on production material as determined by the Engineer.”

Revise the title of Article 1030.06(b) of the Standard Specifications to read:

“(b) Low ESAL Mixtures.”

System for Hydrated Lime Addition. Revise the fourth sentence of the third paragraph of Article 1030.04(c) of the Standard Specifications to read:

“The method of application shall be according to Article 1102.01(a)(10).”

Replace the first three sentences of the second paragraph of Article 1102.01(a)(10) of the Standard Specifications to read:

“When hydrated lime is used as the anti-strip additive, a separate bin or tank and feeder system shall be provided to store and accurately proportion the lime onto the aggregate either as a slurry, as dry lime applied to damp aggregates, or as dry lime injected onto the hot aggregates prior to adding the liquid asphalt cement. If the hydrated lime is added either as a slurry or as dry lime on damp aggregates, the lime and aggregates shall be mixed by a power driven pugmill to provide a uniform coating of the lime prior to entering the dryer. If dry hydrated lime is added to the hot dry aggregates in a dryer-drum plant, the lime shall be added in such a manner that the lime will not become entrained into the air stream of the dryer-drum and that thorough dry mixing shall occur prior to the injection point of the liquid asphalt. When a batch plant is used, the hydrated lime shall be added to the mixture in the weigh hopper or as approved by the Engineer.”

Basis of Payment. Replace the seventh paragraph of Article 406.14 of the Standard Specifications with the following:

“For mixes designed and verified under the Hamburg Wheel criteria, the cost of furnishing and introducing anti-stripping additives in the HMA will not be paid for separately, but shall be considered as included in the contract unit price of the HMA item involved.

If an anti-stripping additive is required for any other HMA mix, the cost of the additive will be paid for according to Article 109.04. The cost incurred in introducing the additive into the

HMA will not be paid for separately, but shall be considered as included in the contract unit price of the HMA item involved.

No additional compensation will be awarded to the Contractor because of reduced production rates associated with the addition of the anti-stripping additive.”

80323

NOT FOR BID

**HOT MIX ASPHALT – PRIME COAT (BDE)**

Effective: November 1, 2014

Revise Note 1 of Article 406.02 of the Standard Specifications to read:

“Note 1. The bituminous material used for prime coat shall be one of the types listed in the following table.

When emulsified asphalts are used, any dilution with water shall be performed by the emulsion producer. The emulsified asphalt shall be thoroughly agitated within 24 hours of application and show no separation of water and emulsion.

Application	Bituminous Material Types
Prime Coat on Brick, Concrete, or HMA Bases	SS-1, SS-1h, SS-1hP, SS-1vh, RS-1, RS-2, CSS-1, CSS-1h, CSS-1hp, CRS-1, CRS-2, HFE-90, RC-70
Prime Coat on Aggregate Bases	MC-30, PEP”

Add the following to Article 406.03 of the Standard Specifications.

- “(i) Vacuum Sweeper ..... 1101.19
- “(j) Spray Paver ..... 1102.06”

Revise Article 406.05(b) of the Standard Specifications to read:

“(b) Prime Coat. The bituminous material shall be prepared according to Article 403.05 and applied according to Article 403.10. The use of RC-70 shall be limited to air temperatures less than 60 °F (15 °C).

(1) Brick, Concrete or HMA Bases. The base shall be cleaned of all dust, debris and any substance that will prevent the prime coat from adhering to the base. Cleaning shall be accomplished by sweeping to remove all large particles and air blasting to remove dust. As an alternative to air blasting, a vacuum sweeper may be used to accomplish the dust removal. The base shall be free of standing water at the time of application. The prime coat shall be applied uniformly and at a rate that will provide a residual asphalt rate on the prepared surface as specified in the following table.

Type of Surface to be Primed	Residual Asphalt Rate lb/sq ft (kg/sq m)
Milled HMA, Aged Non-Milled HMA, Milled Concrete, Non-Milled Concrete & Tined Concrete	0.05 (0.244)
Fog Coat between HMA Lifts, IL-4.75 & Brick	0.025 (0.122)

The bituminous material for the prime coat shall be placed one lane at a time. If a spray paver is not used, the primed lane shall remain closed until the prime coat is

fully cured and does not pickup under traffic. When placing prime coat through an intersection where it is not possible to keep the lane closed, the prime coat may be covered immediately following its application with fine aggregate mechanically spread at a uniform rate of 2 to 4 lb/sq yd (1 to 2 kg/sq m).

- (2) Aggregate Bases. The prime coat shall be applied uniformly and at a rate that will provide a residual asphalt rate on the prepared surface of 0.25 lb/sq ft  $\pm$  0.01 (1.21 kg/sq m  $\pm$ 0.05).

The prime coat shall be permitted to cure until the penetration has been approved by the Engineer, but at no time shall the curing period be less than 24 hours for MC-30 or four hours for PEP. Pools of prime occurring in the depressions shall be broomed or squeegeed over the surrounding surface the same day the prime coat is applied.

The base shall be primed 1/2 width at a time. The prime coat on the second half/width shall not be applied until the prime coat on the first half/width has cured so that it will not pickup under traffic.

The residual asphalt rate will be verified a minimum of once per type of surface to be primed as specified herein for which at least 2000 tons (1800 metric tons) of HMA will be placed. The test will be according to the "Determination of Residual Asphalt in Prime and Tack Coat Materials" test procedure.

Prime coat shall be fully cured prior to placement of HMA to prevent pickup by haul trucks or paving equipment. If pickup occurs, paving shall cease in order to provide additional cure time, and all areas where the pickup occurred shall be repaired.

If after five days, loss of prime coat is evident prior to covering with HMA, additional prime coat shall be placed as determined by the Engineer at no additional cost to the Department."

Revise the last sentence of the first paragraph of Article 406.13(b) of the Standard Specifications to read:

"Water added to emulsified asphalt, as allowed in Article 406.02, will not be included in the quantities measured for payment."

Revise the second paragraph of Article 406.13(b) of the Standard Specifications to read:

"Aggregate for covering prime coat will not be measured for payment."

Revise the first paragraph of Article 406.14 of the Standard Specifications to read:

**"406.14 Basis of Payment.** Prime Coat will be paid for at the contract unit price per pound (kilogram) of residual asphalt applied for BITUMINOUS MATERIALS (PRIME COAT), or POLYMERIZED BITUMINOUS MATERIALS (PRIME COAT)."

Revise Article 407.02 of the Standard Specifications to read:

**“407.02 Materials.** Materials shall be according to Article 406.02, except as follows.

Item	Article/Section
(a) Packaged Rapid Hardening Mortar or Concrete .....	1018”

Revise Article 407.06(b) of the Standard Specifications to read:

“(b) A bituminous prime coat shall be applied between each lift of HMA according to Article 406.05(b).”

Delete the second paragraph of Article 407.12 of the Standard Specifications.

Revise the first paragraph of Article 408.04 of the Standard Specifications to read:

**“408.04 Method of Measurement.** Bituminous priming material will be measured for payment according to Article 406.13.”

Revise the first paragraph of Article 408.05 of the Standard Specifications to read:

**“408.05 Basis of Payment.** This work will be paid for at the contract unit price per pound (kilogram) of residual asphalt applied for BITUMINOUS MATERIALS (PRIME COAT) or POLYMERIZED BITUMINOUS MATERIALS (PRIME COAT) and at the contract unit price per ton (metric ton) for INCIDENTAL HOT-MIX ASPHALT SURFACING.”

Revise Article 1032.02 of the Standard Specifications to read:

**“1032.02 Measurement.** Asphalt binders, emulsified asphalts, rapid curing liquid asphalt, medium curing liquid asphalts, slow curing liquid asphalts, asphalt fillers, and road oils will be measured by weight.

A weight ticket for each truck load shall be furnished to the inspector. The truck shall be weighed at a location approved by the Engineer. The ticket shall show the weight of the empty truck (the truck being weighed each time before it is loaded), the weight of the loaded truck, and the net weight of the bituminous material.

When an emulsion or cutback is used for prime coat, the percentage of asphalt residue of the actual certified product shall be shown on the producer’s bill of lading or attached certificate of analysis. If the producer adds extra water to an emulsion at the request of the purchaser, the amount of water shall also be shown on the bill of lading.

Payment will not be made for bituminous materials in excess of 105 percent of the amount specified by the Engineer.”

Add the following to the table in Article 1032.04 of the Standard Specifications.

"SS-1vh	160-180	70-80
RS-1, CRS-1	75-130	25-55"

Add the following to Article 1032.06 of the Standard Specifications.

"(g) Non Tracking Emulsified Asphalt SS-1vh shall be according to the following.

Requirements for SS-1vh			
Test		SPEC	AASHTO Test Method
Saybolt Viscosity @ 25C,	SFS	20-200	T 72
Storage Stability, 24hr.,	%	1 max.	T 59
Residue by Evaporation,	%	50 min.	T 59
Sieve Test,	%	0.3 max.	T 59
Tests on Residue from Evaporation			
Penetration @25°C, 100g., 5 sec.,	dmm	20 max.	T 49
Softening Point,	°C	65 min.	T 53
Solubility,	%	97.5 min.	T 44
Orig. DSR @ 82°C,	kPa	1.00 min.	T 315"

Revise the last table in Article 1032.06(f)(2)d. of the Standard Specifications to read:

"Grade	Use
SS-1, SS-1h, RS-1, RS-2, CSS-1, CRS-1, CRS-2, CSS-1h, HFE-90, SS-1hP, CSS-1hP, SS-1vh	Prime or fog seal
PEP	Bituminous surface treatment prime
RS-2, HFE-90, HFE-150, HFE- 300, CRSP, HFP, CRS-2, HFRS-2	Bituminous surface treatment
CSS-1h Latex Modified	Microsurfacing"

Add the following to Article 1101 of the Standard Specifications.

**"1101.19 Vacuum Sweeper.** The vacuum sweeper shall have a minimum sweeping path of 52 in. (1.3 m) and a minimum blower rating of 20,000 cu ft per minute (566 cu m per minute)."

Add the following to Article 1102 of the Standard Specifications:

**"1102.06 Spray Paver.** The spreading and finishing machine shall be capable of spraying a rapid setting emulsion tack coat, paving a layer of HMA, and providing a smooth HMA mat in one pass. The HMA shall be spread over the tack coat in less than five seconds after the

application of the tack coat during normal paving speeds. No wheel or other part of the paving machine shall come into contact with the tack coat before the HMA is applied. In addition to meeting the requirements of Article 1102.03, the spray paver shall also meet the requirements of Article 1102.05 for the tank, heating system, pump, thermometer, tachometer or synchronizer, and calibration. The spray bar shall be equipped with properly sized and spaced nozzles to apply a uniform application of tack coat at the specified rate for the full width of the mat being placed.”

80348

NOT FOR BIDD

## **PAVEMENT PATCHING (BDE)**

Effective: January 1, 2010

Revise the first sentence of the second paragraph of Article 701.17(e)(1) of the Standard Specifications to read:

“In addition to the traffic control and protection shown elsewhere in the contract for pavement, two devices shall be placed immediately in front of each open patch, open hole, and broken pavement where temporary concrete barriers are not used to separate traffic from the work area.”

80254

## WARM MIX ASPHALT (BDE)

Effective: January 1, 2012

Revised: November 1, 2014

Description. This work shall consist of designing, producing and constructing Warm Mix Asphalt (WMA) in lieu of Hot Mix Asphalt (HMA) at the Contractor's option. Work shall be according to Sections 406, 407, 408, 1030, and 1102 of the Standard Specifications, except as modified herein. In addition, any references to HMA in the Standard Specifications, or the special provisions shall be construed to include WMA.

WMA is an asphalt mixture which can be produced at temperatures lower than allowed for HMA utilizing approved WMA technologies. WMA technologies are defined as the use of additives or processes which allow a reduction in the temperatures at which HMA mixes are produced and placed. WMA is produced by the use of additives, a water foaming process, or combination of both. Additives include minerals, chemicals or organics incorporated into the asphalt binder stream in a dedicated delivery system. The process of foaming injects water into the asphalt binder stream, just prior to incorporation of the asphalt binder with the aggregate.

Approved WMA technologies may also be used in HMA provided all the requirements specified herein, with the exception of temperature, are met. However, asphalt mixtures produced at temperatures in excess of 275 °F (135 °C) will not be considered WMA when determining the grade reduction of the virgin asphalt binder grade.

### Equipment.

Revise the first paragraph of Article 1102.01 of the Standard Specifications to read:

**“1102.01 Hot-Mix Asphalt Plant.** The hot-mix asphalt (HMA) plant shall be the batch-type, continuous-type, or dryer drum plant. The plants shall be evaluated for prequalification rating and approval to produce HMA according to the current Bureau of Materials and Physical Research Policy Memorandum, “Approval of Hot-Mix Asphalt Plants and Equipment”. Once approved, the Contractor shall notify the Bureau of Materials and Physical Research to obtain approval of all plant modifications. The plants shall not be used to produce mixtures concurrently for more than one project or for private work unless permission is granted in writing by the Engineer. The plant units shall be so designed, coordinated and operated that they will function properly and produce HMA having uniform temperatures and compositions within the tolerances specified. The plant units shall meet the following requirements.”

Add the following to Article 1102.01(a) of the Standard Specifications.

“(13) Equipment for Warm Mix Technologies.

- a. Foaming. Metering equipment for foamed asphalt shall have an accuracy of  $\pm 2$  percent of the actual water metered. The foaming control system shall be electronically interfaced with the asphalt binder meter.

- b. Additives. Additives shall be introduced into the plant according to the supplier's recommendations and shall be approved by the Engineer. The system for introducing the WMA additive shall be interlocked with the aggregate feed or weigh system to maintain correct proportions for all rates of production and batch sizes."

Mix Design Verification.

Add the following to Article 1030.04 of the Standard Specifications.

"(e) Warm Mix Technologies.

- (1) Foaming. WMA mix design verification will not be required when foaming technology is used alone (without WMA additives). However, the foaming technology shall only be used on HMA designs previously approved by the Department.
- (2) Additives. WMA mix designs utilizing additives shall be submitted to the Engineer for mix design verification."

Construction Requirements.

Revise the second paragraph of Article 406.06(b)(1) of the Standard Specifications to read:

"The HMA shall be delivered at a temperature of 250 to 350 °F (120 to 175 °C).  
WMA shall be delivered at a minimum temperature of 215 °F (102 °C)."

Basis of Payment.

This work will be paid at the contract unit price bid for the HMA pay items involved. Anti-strip will not be paid for separately, but shall be considered as included in the cost of the work.

80288

NOT FOR BID

State of Illinois  
Department of Transportation  
Bureau of Local Roads and Streets

SPECIAL PROVISION  
FOR  
INSURANCE

Effective: February 1, 2007  
Revised: August 1, 2007

All references to Sections or Articles in this specification shall be construed to mean specific Section or Article of the Standard Specifications for Road and Bridge Construction, adopted by the Department of Transportation.

The Contractor shall name the following entities as additional insured under the Contractor's general liability insurance policy in accordance with Article 107.27:

Village of Villa Park, IL

---

Robinson Engineering, Ltd.

---

Clark Dietz, Inc.

---

---

---

---

---

---

The entities listed above and their officers, employees, and agents shall be indemnified and held harmless in accordance with Article 107.26.

NOT FOR BID

State of Illinois  
Department of Transportation  
Bureau of Local Roads and Streets

SPECIAL PROVISION  
FOR  
EQUIPMENT RENTAL RATES

Effective: January 1, 2012

All references to Sections or Articles in this specification shall be construed to mean a specific Section or Article of the Standard Specifications for Road and Bridge Construction, adopted by the Department of Transportation.

Replace Article 109.04(b)(4) with the following:

- "(4) Equipment. For any machinery or special equipment (other than small tools) the use of which has been authorized by the Engineer, the Contractor will be paid according to the latest revision of "SCHEDULE OF AVERAGE ANNUAL EQUIPMENT OWNERSHIP EXPENSE" and latest index factor as issued by the Illinois Department of Transportation. The equipment should be of a type and size reasonably required to complete the extra work."

NOT FOR BID

# Du Page County Prevailing Wage for June 2015

(See explanation of column headings at bottom of wages)

Trade Name	RG	TYP	C	Base	FRMAN	M-F>8	OSA	OSH	H/W	Pensn	Vac	Trng
=====	==	=	=	=====	=====	=====	=====	=====	=====	=====	=====	=====
ASBESTOS ABT-GEN		ALL		38.200	38.700	1.5	1.5	2.0	13.78	10.12	0.000	0.500
ASBESTOS ABT-MEC		BLD		35.100	37.600	1.5	1.5	2.0	11.17	10.76	0.000	0.720
BOILERMAKER		BLD		45.650	49.760	2.0	2.0	2.0	6.970	17.81	0.000	0.400
BRICK MASON		BLD		42.580	46.840	1.5	1.5	2.0	9.850	13.60	0.000	1.030
CARPENTER		ALL		43.350	45.350	1.5	1.5	2.0	13.29	13.75	0.000	0.630
CEMENT MASON		ALL		39.250	41.250	2.0	1.5	2.0	12.70	17.14	0.000	0.450
CERAMIC TILE FNSHER		BLD		35.810	0.000	1.5	1.5	2.0	10.55	8.440	0.000	0.710
COMMUNICATION TECH		BLD		32.650	34.750	1.5	1.5	2.0	9.550	15.16	1.250	0.610
ELECTRIC PWR EQMT OP		ALL		37.890	51.480	1.5	1.5	2.0	5.000	11.75	0.000	0.380
ELECTRIC PWR EQMT OP		HWY		39.220	53.290	1.5	1.5	2.0	5.000	12.17	0.000	0.390
ELECTRIC PWR GRNDMAN		ALL		29.300	51.480	1.5	1.5	2.0	5.000	9.090	0.000	0.290
ELECTRIC PWR GRNDMAN		HWY		30.330	53.290	1.5	1.5	2.0	5.000	9.400	0.000	0.300
ELECTRIC PWR LINEMAN		ALL		45.360	51.480	1.5	1.5	2.0	5.000	14.06	0.000	0.450
ELECTRIC PWR LINEMAN		HWY		46.950	53.290	1.5	1.5	2.0	5.000	14.56	0.000	0.470
ELECTRIC PWR TRK DRV		ALL		30.340	51.480	1.5	1.5	2.0	5.000	9.400	0.000	0.300
ELECTRIC PWR TRK DRV		HWY		31.400	53.290	1.5	1.5	2.0	5.000	9.730	0.000	0.310
ELECTRICIAN		BLD		38.160	41.980	1.5	1.5	2.0	9.550	18.29	4.680	0.680
ELEVATOR CONSTRUCTOR		BLD		50.800	57.150	2.0	2.0	2.0	13.57	14.21	4.060	0.600
FENCE ERECTOR	NE	ALL		35.840	37.840	1.5	1.5	2.0	13.01	11.51	0.000	0.300
FENCE ERECTOR	W	ALL		45.060	48.660	2.0	2.0	2.0	10.52	18.81	0.000	0.400
GLAZIER		BLD		40.000	41.500	1.5	2.0	2.0	12.49	15.99	0.000	0.940
HT/FROST INSULATOR		BLD		48.450	50.950	1.5	1.5	2.0	11.47	12.16	0.000	0.720
IRON WORKER	E	ALL		43.000	45.000	2.0	2.0	2.0	13.45	20.65	0.000	0.350
IRON WORKER	W	ALL		45.060	48.660	2.0	2.0	2.0	10.52	18.81	0.000	0.400
LABORER		ALL		38.000	38.750	1.5	1.5	2.0	13.78	10.12	0.000	0.500
LATHER		ALL		43.350	45.350	1.5	1.5	2.0	13.29	13.75	0.000	0.630
MACHINIST		BLD		44.350	46.850	1.5	1.5	2.0	6.760	8.950	1.850	0.000
MARBLE FINISHERS		ALL		31.400	32.970	1.5	1.5	2.0	9.850	13.10	0.000	0.600
MARBLE MASON		BLD		41.780	45.960	1.5	1.5	2.0	9.850	13.42	0.000	0.760
MATERIAL TESTER I		ALL		28.000	0.000	1.5	1.5	2.0	13.78	10.12	0.000	0.500
MATERIALS TESTER II		ALL		33.000	0.000	1.5	1.5	2.0	13.78	10.12	0.000	0.500
MILLWRIGHT		ALL		43.350	45.350	1.5	1.5	2.0	13.29	13.75	0.000	0.630
OPERATING ENGINEER		BLD 1		47.100	51.100	2.0	2.0	2.0	17.10	11.80	1.900	1.250
OPERATING ENGINEER		BLD 2		45.800	51.100	2.0	2.0	2.0	17.10	11.80	1.900	1.250
OPERATING ENGINEER		BLD 3		43.250	51.100	2.0	2.0	2.0	17.10	11.80	1.900	1.250
OPERATING ENGINEER		BLD 4		41.500	51.100	2.0	2.0	2.0	17.10	11.80	1.900	1.250
OPERATING ENGINEER		BLD 5		50.850	51.100	2.0	2.0	2.0	17.10	11.80	1.900	1.250
OPERATING ENGINEER		BLD 6		48.100	51.100	2.0	2.0	2.0	17.10	11.80	1.900	1.250
OPERATING ENGINEER		BLD 7		50.100	51.100	2.0	2.0	2.0	17.10	11.80	1.900	1.250
OPERATING ENGINEER		FLT		35.000	35.000	1.5	1.5	2.0	16.60	11.05	1.900	1.250
OPERATING ENGINEER		HWY 1		45.300	49.300	1.5	1.5	2.0	17.10	11.80	1.900	1.250
OPERATING ENGINEER		HWY 2		44.750	49.300	1.5	1.5	2.0	17.10	11.80	1.900	1.250
OPERATING ENGINEER		HWY 3		42.700	49.300	1.5	1.5	2.0	17.10	11.80	1.900	1.250
OPERATING ENGINEER		HWY 4		41.300	49.300	1.5	1.5	2.0	17.10	11.80	1.900	1.250
OPERATING ENGINEER		HWY 5		40.100	49.300	1.5	1.5	2.0	17.10	11.80	1.900	1.250
OPERATING ENGINEER		HWY 6		48.300	49.300	1.5	1.5	2.0	17.10	11.80	1.900	1.250
OPERATING ENGINEER		HWY 7		46.300	49.300	1.5	1.5	2.0	17.10	11.80	1.900	1.250
ORNAMNTL IRON WORKER E		ALL		43.900	46.400	2.0	2.0	2.0	13.36	17.24	0.000	0.650
ORNAMNTL IRON WORKER W		ALL		45.060	48.660	2.0	2.0	2.0	10.52	18.81	0.000	0.400
PAINTER		ALL		41.730	43.730	1.5	1.5	1.5	10.30	8.200	0.000	1.350
PAINTER SIGNS		BLD		33.920	38.090	1.5	1.5	1.5	2.600	2.710	0.000	0.000
PILEDRIVER		ALL		43.350	45.350	1.5	1.5	2.0	13.29	13.75	0.000	0.630
PIPEFITTER		BLD		46.000	49.000	1.5	1.5	2.0	9.000	15.85	0.000	1.780
PLASTERER		BLD		41.250	43.760	1.5	1.5	2.0	9.700	13.08	0.000	0.980
PLUMBER		BLD		46.650	48.650	1.5	1.5	2.0	13.18	11.46	0.000	0.880

ROOFER	BLD	40.100	43.100	1.5	1.5	2.0	8.280	10.54	0.000	0.530
SHEETMETAL WORKER	BLD	44.000	46.000	1.5	1.5	2.0	10.65	13.06	0.000	0.820
SPRINKLER FITTER	BLD	49.200	51.200	1.5	1.5	2.0	11.75	9.650	0.000	0.550
STEEL ERECTOR	E ALL	42.070	44.070	2.0	2.0	2.0	13.45	19.59	0.000	0.350
STEEL ERECTOR	W ALL	45.060	48.660	2.0	2.0	2.0	10.52	18.81	0.000	0.400
STONE MASON	BLD	42.580	46.840	1.5	1.5	2.0	9.850	13.60	0.000	1.030
<del>SURVEY WORKER</del>	-> NOT IN EFFECT			ALL	37.000	37.750	1.5	1.5	2.0	12.97
9.930	0.000	0.500								
TERRAZZO FINISHER	BLD	37.040	0.000	1.5	1.5	2.0	10.55	10.32	0.000	0.620
TERRAZZO MASON	BLD	40.880	43.880	1.5	1.5	2.0	10.55	11.63	0.000	0.820
TILE MASON	BLD	42.840	46.840	1.5	1.5	2.0	10.55	10.42	0.000	0.920
TRAFFIC SAFETY WRKR	HWY	32.750	34.350	1.5	1.5	2.0	6.550	6.450	0.000	0.500
TRUCK DRIVER	ALL 1	32.550	33.100	1.5	1.5	2.0	6.500	4.350	0.000	0.150
TRUCK DRIVER	ALL 2	32.700	33.100	1.5	1.5	2.0	6.500	4.350	0.000	0.150
TRUCK DRIVER	ALL 3	32.900	33.100	1.5	1.5	2.0	6.500	4.350	0.000	0.150
TRUCK DRIVER	ALL 4	33.100	33.100	1.5	1.5	2.0	6.500	4.350	0.000	0.150
TUCKPOINTER	BLD	41.620	42.620	1.5	1.5	2.0	9.850	12.61	0.000	0.650

Legend: RG (Region)

TYP (Trade Type - All, Highway, Building, Floating, Oil & Chip, Rivers)

C (Class)

Base (Base Wage Rate)

FRMAN (Foreman Rate)

M-F>8 (OT required for any hour greater than 8 worked each day, Mon through Fri.)

OSA (Overtime (OT) is required for every hour worked on Saturday)

OSH (Overtime is required for every hour worked on Sunday and Holidays)

H/W (Health & Welfare Insurance)

Pensn (Pension)

Vac (Vacation)

Trng (Training)

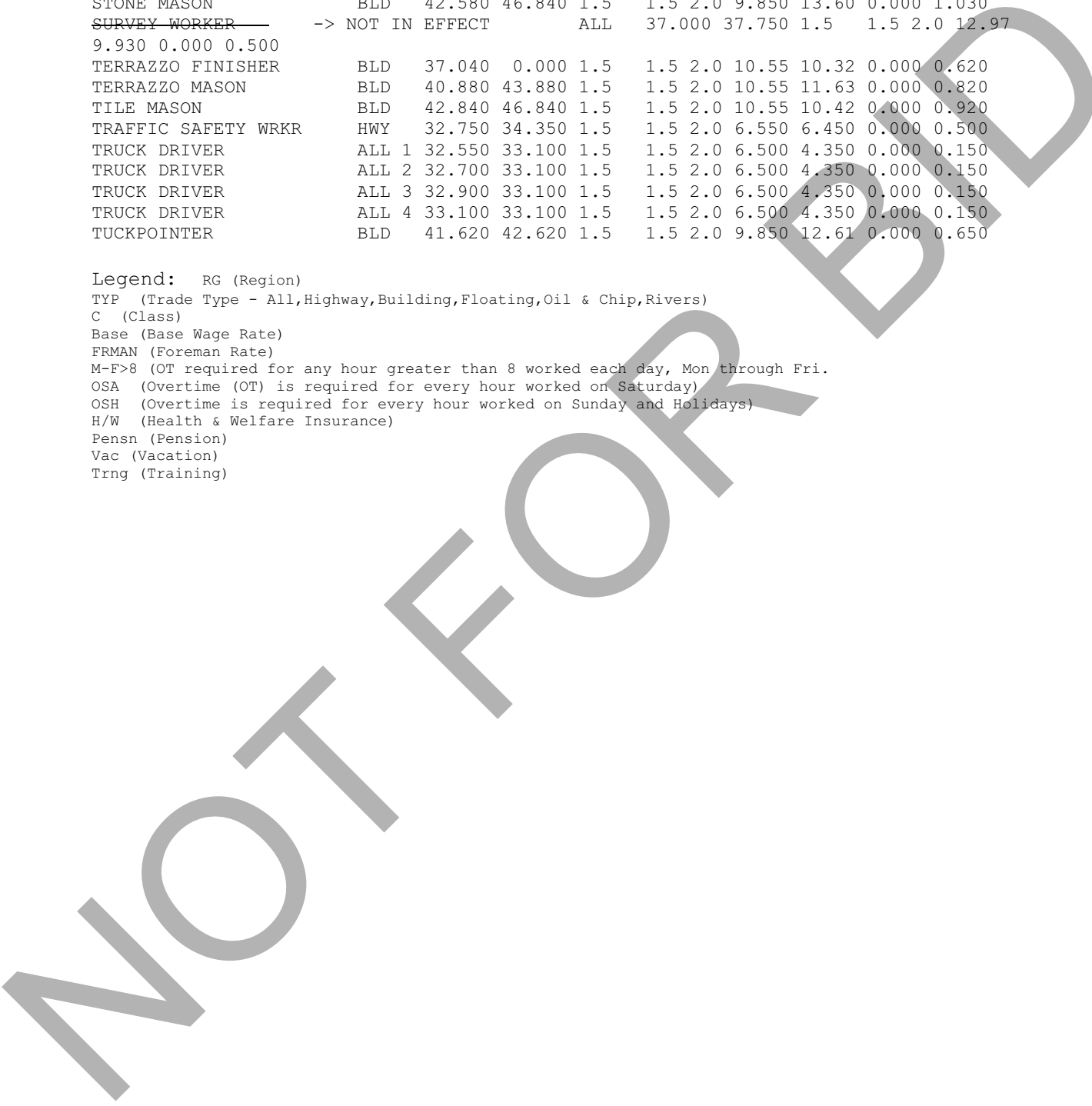

# Explanations

DUPAGE COUNTY

IRON WORKERS AND FENCE ERECTOR (WEST) - West of Route 53.

The following list is considered as those days for which holiday rates of wages for work performed apply: New Years Day, Memorial Day, Fourth of July, Labor Day, Thanksgiving Day, Christmas Day and Veterans Day in some classifications/counties. Generally, any of these holidays which fall on a Sunday is celebrated on the following Monday. This then makes work performed on that Monday payable at the appropriate overtime rate for holiday pay. Common practice in a given local may alter certain days of celebration. If in doubt, please check with IDOL.

## EXPLANATION OF CLASSES

ASBESTOS - GENERAL - removal of asbestos material/mold and hazardous materials from any place in a building, including mechanical systems where those mechanical systems are to be removed. This includes the removal of asbestos materials/mold and hazardous materials from ductwork or pipes in a building when the building is to be demolished at the time or at some close future date.

ASBESTOS - MECHANICAL - removal of asbestos material from mechanical systems, such as pipes, ducts, and boilers, where the mechanical systems are to remain.

TRAFFIC SAFETY - work associated with barricades, horses and drums used to reduce lane usage on highway work, the installation and removal of temporary lane markings, and the installation and removal of temporary road signs.

## CERAMIC TILE FINISHER

The grouting, cleaning, and polishing of all classes of tile, whether for interior or exterior purposes, all burned, glazed or unglazed products; all composition materials, granite tiles, warning detectable tiles, cement tiles, epoxy composite materials, pavers, glass, mosaics, fiberglass, and all substitute materials, for tile made in tile-like units; all mixtures in tile like form of cement, metals, and other materials that are for and intended for use as a finished floor surface, stair treads, promenade roofs, walks, walls, ceilings, swimming pools, and all other places where tile is to form a finished interior or exterior. The mixing of all setting mortars including but not limited to thin-set mortars, epoxies, wall mud, and any other sand and cement mixtures or adhesives when used in the preparation, installation, repair, or maintenance of tile and/or similar materials. The handling and unloading of all sand, cement, lime, tile, fixtures, equipment, adhesives, or any other materials to be used in the preparation, installation, repair, or maintenance of tile and/or similar materials. Ceramic Tile Finishers shall fill all joints and voids regardless of method on all tile work, particularly and especially after installation of said tile work. Application of any and all protective coverings to all types of tile installations

including, but not be limited to, all soap compounds, paper products, tapes, and all polyethylene coverings, plywood, masonite, cardboard, and any new type of products that may be used to protect tile installations, Blastrac equipment, and all floor scarifying equipment used in preparing floors to receive tile. The clean up and removal of all waste and materials. All demolition of existing tile floors and walls to be re-tiled.

#### COMMUNICATIONS TECHNICIAN

Low voltage installation, maintenance and removal of telecommunication facilities (voice, sound, data and video) including telephone and data inside wire, interconnect, terminal equipment, central offices, PABX, fiber optic cable and equipment, micro waves, V-SAT, bypass, CATV, WAN (wide area networks), LAN (local area networks), and ISDN (integrated system digital network), pulling of wire in raceways, but not the installation of raceways.

#### MARBLE FINISHER

Loading and unloading trucks, distribution of all materials (all stone, sand, etc.), stocking of floors with material, performing all rigging for heavy work, the handling of all material that may be needed for the installation of such materials, building of scaffolding, polishing if needed, patching, waxing of material if damaged, pointing up, caulking, grouting and cleaning of marble, holding water on diamond or Carborundum blade or saw for setters cutting, use of tub saw or any other saw needed for preparation of material, drilling of holes for wires that anchor material set by setters, mixing up of molding plaster for installation of material, mixing up thin set for the installation of material, mixing up of sand to cement for the installation of material and such other work as may be required in helping a Marble Setter in the handling of all material in the erection or installation of interior marble, slate, travertine, art marble, serpentine, alberene stone, blue stone, granite and other stones (meaning as to stone any foreign or domestic materials as are specified and used in building interiors and exteriors and customarily known as stone in the trade), carrara, sanionyx, vitrolite and similar opaque glass and the laying of all marble tile, terrazzo tile, slate tile and precast tile, steps, risers treads, base, or any other materials that may be used as substitutes for any of the aforementioned materials and which are used on interior and exterior which are installed in a similar manner.

MATERIAL TESTER I: Hand coring and drilling for testing of materials; field inspection of uncured concrete and asphalt.

MATERIAL TESTER II: Field inspection of welds, structural steel, fireproofing, masonry, soil, facade, reinforcing steel, formwork, cured concrete, and concrete and asphalt batch plants; adjusting proportions of bituminous mixtures.

#### OPERATING ENGINEER - BUILDING

Class 1. Asphalt Plant; Asphalt Spreader; Autograde; Backhoes with Caisson Attachment; Batch Plant; Benoto (requires Two Engineers); Boiler and Throttle Valve; Caisson Rigs; Central Redi-Mix Plant;

Combination Back Hoe Front End-loader Machine; Compressor and Throttle Valve; Concrete Breaker (Truck Mounted); Concrete Conveyor; Concrete Conveyor (Truck Mounted); Concrete Paver Over 27E cu. ft; Concrete Paver 27E cu. ft. and Under; Concrete Placer; Concrete Placing Boom; Concrete Pump (Truck Mounted); Concrete Tower; Cranes, All; Cranes, Hammerhead; Cranes, (GCI and similar Type); Creter Crane; Spider Crane; Crusher, Stone, etc.; Derricks, All; Derricks, Traveling; Formless Curb and Gutter Machine; Grader, Elevating; Grouting Machines; Heavy Duty Self-Propelled Transporter or Prime Mover; Highlift Shovels or Front Endloader 2-1/4 yd. and over; Hoists, Elevators, outside type rack and pinion and similar machines; Hoists, One, Two and Three Drum; Hoists, Two Tugger One Floor; Hydraulic Backhoes; Hydraulic Boom Trucks; Hydro Vac (and similar equipment); Locomotives, All; Motor Patrol; Lubrication Technician; Manipulators; Pile Drivers and Skid Rig; Post Hole Digger; Pre-Stress Machine; Pump Cretes Dual Ram; Pump Cretes: Squeeze Cretes-Screw Type Pumps; Gypsum Bulker and Pump; Raised and Blind Hole Drill; Roto Mill Grinder; Scoops - Tractor Drawn; Slip-Form Paver; Straddle Buggies; Operation of Tie Back Machine; Tournapull; Tractor with Boom and Side Boom; Trenching Machines.

Class 2. Boilers; Broom, All Power Propelled; Bulldozers; Concrete Mixer (Two Bag and Over); Conveyor, Portable; Forklift Trucks; Highlift Shovels or Front Endloaders under 2-1/4 yd.; Hoists, Automatic; Hoists, Inside Elevators; Hoists, Sewer Dragging Machine; Hoists, Tugger Single Drum; Laser Screed; Rock Drill (Self-Propelled); Rock Drill (Truck Mounted); Rollers, All; Steam Generators; Tractors, All; Tractor Drawn Vibratory Roller; Winch Trucks with "A" Frame.

Class 3. Air Compressor; Combination Small Equipment Operator; Generators; Heaters, Mechanical; Hoists, Inside Elevators (remodeling or renovation work); Hydraulic Power Units (Pile Driving, Extracting, and Drilling); Pumps, over 3" (1 to 3 not to exceed a total of 300 ft.); Low Boys; Pumps, Well Points; Welding Machines (2 through 5); Winches, 4 Small Electric Drill Winches.

Class 4. Bobcats and/or other Skid Steer Loaders; Oilers; and Brick Forklift.

Class 5. Assistant Craft Foreman.

Class 6. Gradall.

Class 7. Mechanics; Welders.

#### OPERATING ENGINEERS - HIGHWAY CONSTRUCTION

Class 1. Asphalt Plant; Asphalt Heater and Planer Combination; Asphalt Heater Scarfire; Asphalt Spreader; Autograder/GOMACO or other similar type machines: ABG Paver; Backhoes with Caisson Attachment; Ballast Regulator; Belt Loader; Caisson Rigs; Car Dumper; Central Redi-Mix Plant; Combination Backhoe Front Endloader Machine, (1 cu. yd. Backhoe Bucket or over or with attachments); Concrete Breaker (Truck Mounted); Concrete Conveyor; Concrete Paver over 27E cu. ft.; Concrete Placer; Concrete Tube Float; Cranes, all attachments; Cranes, Tower Cranes of all types: Creter Crane: Spider Crane; Crusher, Stone, etc.;

Derricks, All; Derrick Boats; Derricks, Traveling; Dredges; Elevators, Outside type Rack & Pinion and Similar Machines; Formless Curb and Gutter Machine; Grader, Elevating; Grader, Motor Grader, Motor Patrol, Auto Patrol, Form Grader, Pull Grader, Subgrader; Guard Rail Post Driver Truck Mounted; Hoists, One, Two and Three Drum; Heavy Duty Self-Propelled Transporter or Prime Mover; Hydraulic Backhoes; Backhoes with shear attachments up to 40' of boom reach; Lubrication Technician; Manipulators; Mucking Machine; Pile Drivers and Skid Rig; Pre-Stress Machine; Pump Cretes Dual Ram; Rock Drill - Crawler or Skid Rig; Rock Drill - Truck Mounted; Rock/Track Tamper; Roto Mill Grinder; Slip-Form Paver; Snow Melters; Soil Test Drill Rig (Truck Mounted); Straddle Buggies; Hydraulic Telescoping Form (Tunnel); Operation of Tieback Machine; Tractor Drawn Belt Loader; Tractor Drawn Belt Loader (with attached pusher - two engineers); Tractor with Boom; Tractaire with Attachments; Traffic Barrier Transfer Machine; Trenching; Truck Mounted Concrete Pump with Boom; Raised or Blind Hole Drills (Tunnel Shaft); Underground Boring and/or Mining Machines 5 ft. in diameter and over tunnel, etc; Underground Boring and/or Mining Machines under 5 ft. in diameter; Wheel Excavator; Widener (APSCO).

Class 2. Batch Plant; Bituminous Mixer; Boiler and Throttle Valve; Bulldozers; Car Loader Trailing Conveyors; Combination Backhoe Front Endloader Machine (Less than 1 cu. yd. Backhoe Bucket or over or with attachments); Compressor and Throttle Valve; Compressor, Common Receiver (3); Concrete Breaker or Hydro Hammer; Concrete Grinding Machine; Concrete Mixer or Paver 7S Series to and including 27 cu. ft.; Concrete Spreader; Concrete Curing Machine, Burlap Machine, Belting Machine and Sealing Machine; Concrete Wheel Saw; Conveyor Muck Cars (Haglund or Similar Type); Drills, All; Finishing Machine - Concrete; Highlift Shovels or Front Endloader; Hoist - Sewer Dragging Machine; Hydraulic Boom Trucks (All Attachments); Hydro-Blaster; Hydro Excavating (excluding hose work); Laser Screed; All Locomotives, Dinky; Off-Road Hauling Units (including articulating) Non Self-Loading Ejection Dump; Pump Cretes: Squeeze Cretes - Screw Type Pumps, Gypsum Bulker and Pump; Roller, Asphalt; Rotary Snow Plows; Rototiller, Seaman, etc., self-propelled; Self-Propelled Compactor; Spreader - Chip - Stone, etc.; Scraper - Single/Twin Engine/Push and Pull; Scraper - Prime Mover in Tandem (Regardless of Size); Tractors pulling attachments, Sheeps Foot, Disc, Compactor, etc.; Tug Boats.

Class 3. Boilers; Brooms, All Power Propelled; Cement Supply Tender; Compressor, Common Receiver (2); Concrete Mixer (Two Bag and Over); Conveyor, Portable; Farm-Type Tractors Used for Mowing, Seeding, etc.; Forklift Trucks; Grouting Machine; Hoists, Automatic; Hoists, All Elevators; Hoists, Tugger Single Drum; Jeep Diggers; Low Boys; Pipe Jacking Machines; Post-Hole Digger; Power Saw, Concrete Power Driven; Pug Mills; Rollers, other than Asphalt; Seed and Straw Blower; Steam Generators; Stump Machine; Winch Trucks with "A" Frame; Work Boats; Tamper-Form-Motor Driven.

Class 4. Air Compressor; Combination - Small Equipment Operator; Directional Boring Machine; Generators; Heaters, Mechanical; Hydraulic Power Unit (Pile Driving, Extracting, or Drilling); Light Plants, All (1 through 5); Pumps, over 3" (1 to 3 not to exceed a total of 300 ft.); Pumps, Well Points; Vacuum Trucks (excluding hose work); Welding Machines (2 through 5); Winches, 4 Small Electric Drill Winches.

Class 5. SkidSteer Loader (all); Brick Forklifts; Oilers.

Class 6. Field Mechanics and Field Welders

Class 7. Dowell Machine with Air Compressor; Gradall and machines of like nature.

OPERATING ENGINEER - FLOATING

Diver. Diver Wet Tender, Diver Tender, ROV Pilot, ROV Tender

SURVEY WORKER - Operated survey equipment including data collectors, G.P.S. and robotic instruments, as well as conventional levels and transits.

TRUCK DRIVER - BUILDING, HEAVY AND HIGHWAY CONSTRUCTION

Class 1. Two or three Axle Trucks. A-frame Truck when used for transportation purposes; Air Compressors and Welding Machines, including those pulled by cars, pick-up trucks and tractors; Ambulances; Batch Gate Lockers; Batch Hopperman; Car and Truck Washers; Carry-alls; Fork Lifts and Hoisters; Helpers; Mechanics Helpers and Greasers; Oil Distributors 2-man operation; Pavement Breakers; Pole Trailer, up to 40 feet; Power Mower Tractors; Self-propelled Chip Spreader; Skipman; Slurry Trucks, 2-man operation; Slurry Truck Conveyor Operation, 2 or 3 man; Teamsters; Unskilled Dumpman; and Truck Drivers hauling warning lights, barricades, and portable toilets on the job site.

Class 2. Four axle trucks; Dump Crets and Adgetors under 7 yards; Dumpsters, Track Trucks, Euclids, Hug Bottom Dump Turnapulls or Turnatrailers when pulling other than self-loading equipment or similar equipment under 16 cubic yards; Mixer Trucks under 7 yards; Ready-mix Plant Hopper Operator, and Winch Trucks, 2 Axles.

Class 3. Five axle trucks; Dump Crets and Adgetors 7 yards and over; Dumpsters, Track Trucks, Euclids, Hug Bottom Dump Turnatrailers or turnapulls when pulling other than self-loading equipment or similar equipment over 16 cubic yards; Explosives and/or Fission Material Trucks; Mixer Trucks 7 yards or over; Mobile Cranes while in transit; Oil Distributors, 1-man operation; Pole Trailer, over 40 feet; Pole and Expandable Trailers hauling material over 50 feet long; Slurry trucks, 1-man operation; Winch trucks, 3 axles or more; Mechanic--Truck Welder and Truck Painter.

Class 4. Six axle trucks; Dual-purpose vehicles, such as mounted crane trucks with hoist and accessories; Foreman; Master Mechanic; Self-loading equipment like P.B. and trucks with scoops on the front.

TERRAZZO FINISHER

The handling of sand, cement, marble chips, and all other materials that may be used by the Mosaic Terrazzo Mechanic, and the mixing, grinding, grouting, cleaning and sealing of all Marble, Mosaic, and

Terrazzo work, floors, base, stairs, and wainscoting by hand or machine, and in addition, assisting and aiding Marble, Masonic, and Terrazzo Mechanics.

Other Classifications of Work:

For definitions of classifications not otherwise set out, the Department generally has on file such definitions which are available. If a task to be performed is not subject to one of the classifications of pay set out, the Department will upon being contacted state which neighboring county has such a classification and provide such rate, such rate being deemed to exist by reference in this document. If no neighboring county rate applies to the task, the Department shall undertake a special determination, such special determination being then deemed to have existed under this determination. If a project requires these, or any classification not listed, please contact IDOL at 217-782-1710 for wage rates or clarifications.

LANDSCAPING

Landscaping work falls under the existing classifications for laborer, operating engineer and truck driver. The work performed by landscape plantsman and landscape laborer is covered by the existing classification of laborer. The work performed by landscape operators (regardless of equipment used or its size) is covered by the classifications of operating engineer. The work performed by landscape truck drivers (regardless of size of truck driven) is covered by the classifications of truck driver.

MATERIAL TESTER & MATERIAL TESTER/INSPECTOR I AND II

Notwithstanding the difference in the classification title, the classification entitled "Material Tester I" involves the same job duties as the classification entitled "Material Tester/Inspector I". Likewise, the classification entitled "Material Tester II" involves the same job duties as the classification entitled "Material Tester/Inspector II".

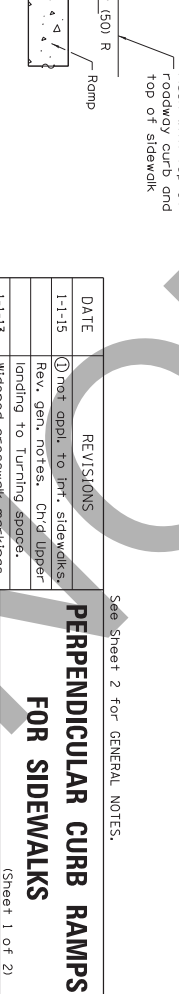
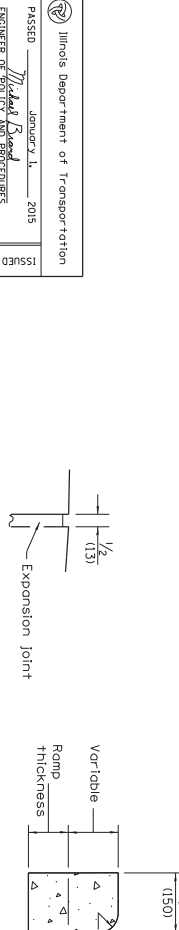
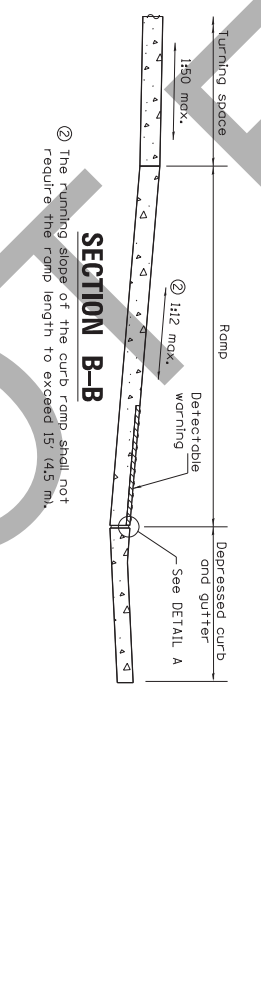
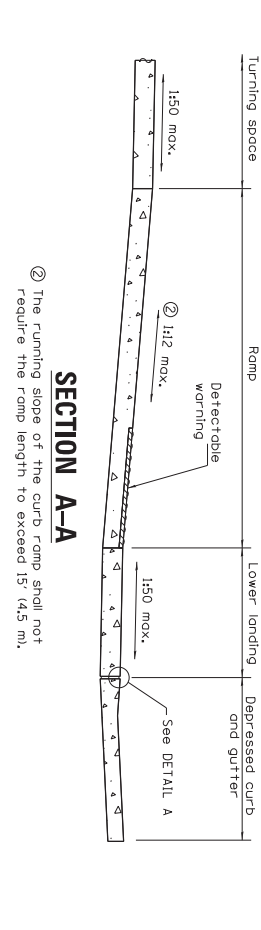
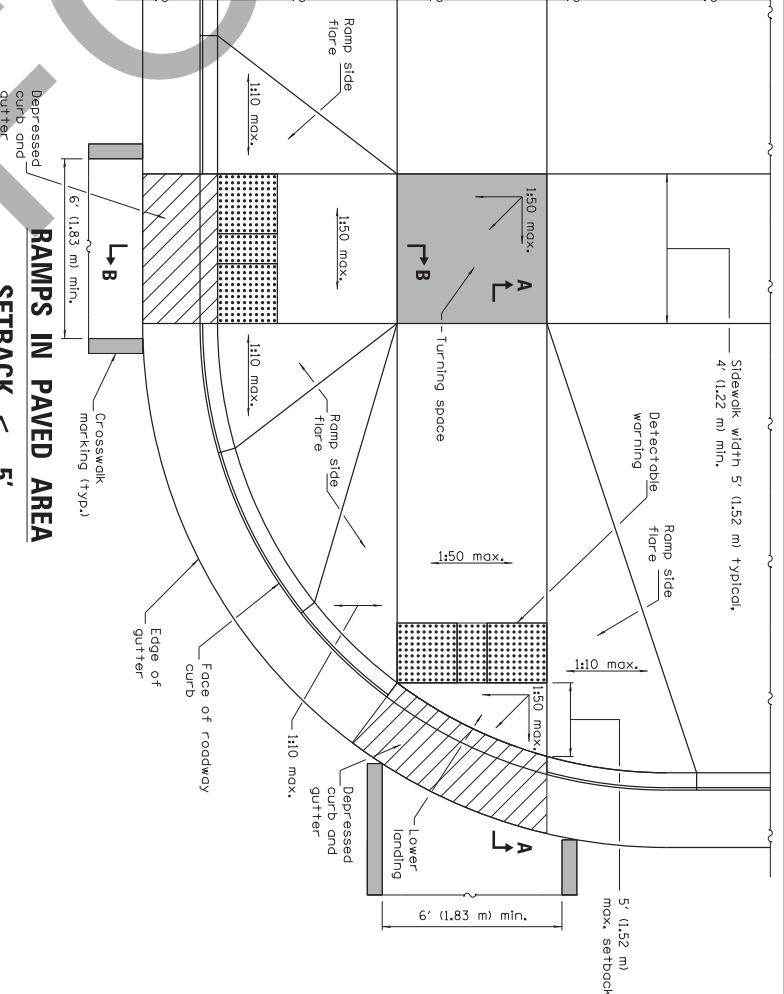
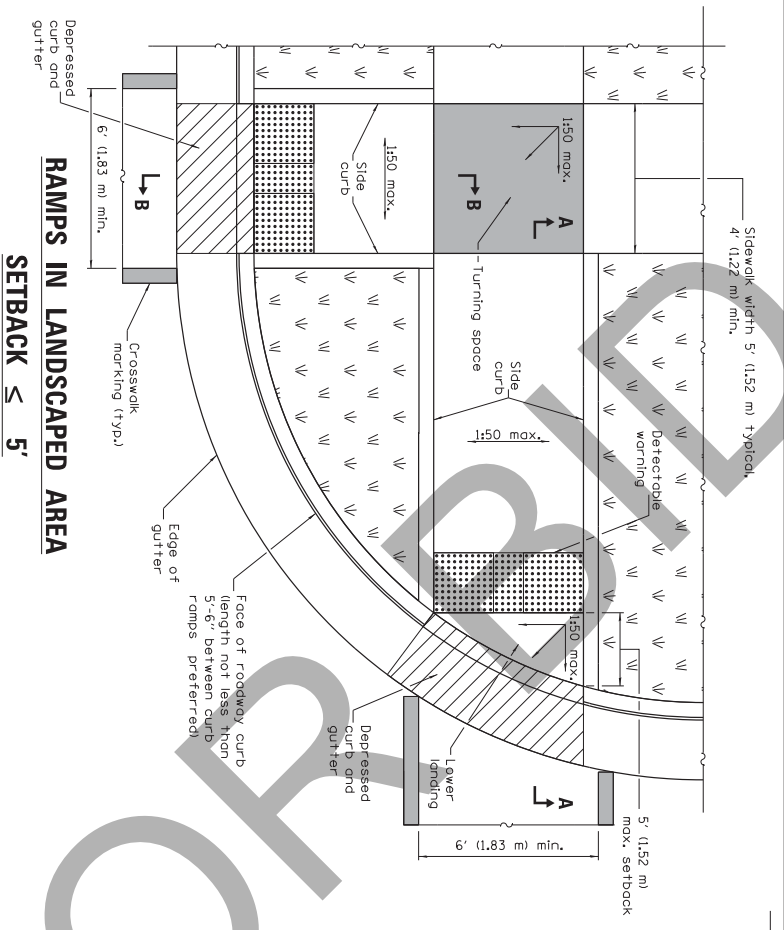

Illinois Department of Transportation  
 PASSED January 1, 2015  
 ENGINEER OF PRACTICE AND PROCEDURES  
 APPROVED January 1, 2015  
 ENGINEER OF DESIGN AND ENVIRONMENT

ISSUED 1-1-97

**PERPENDICULAR CURB RAMPS FOR SIDEWALKS**

DATE	REVISIONS
1-1-15	① not appl. to Int. sidewalks, Rev. gen. notes, Ch'd Upper landing to Turning space.
1-1-13	Widened crosswalk markings to 6' (1.83 m) min. inside dimension, Rev. gen. Notes.

See Sheet 2 for GENERAL NOTES.  
 (Sheet 1 of 2)

**STANDARD 424001-08**

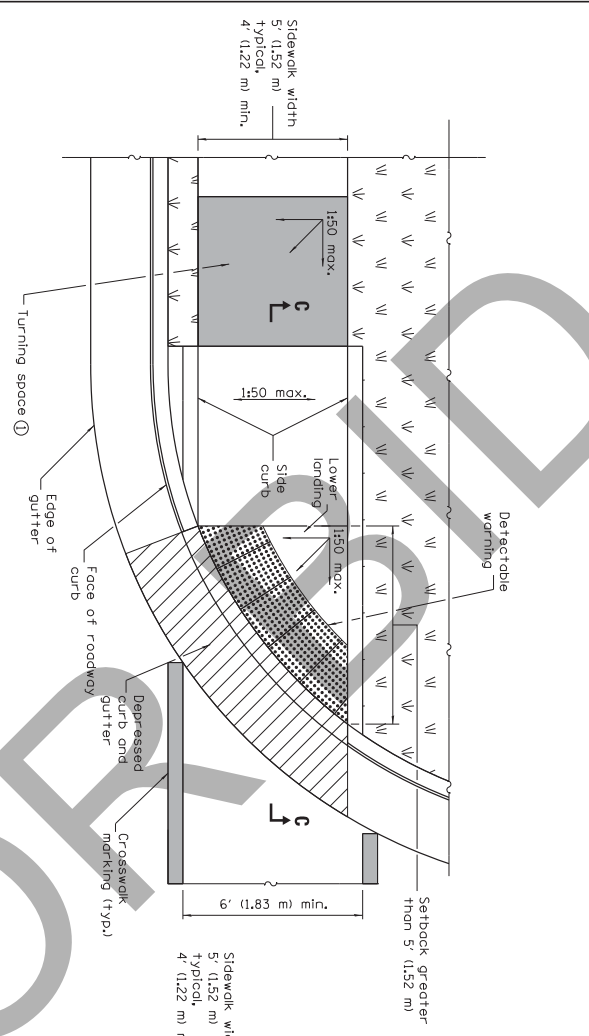

**RAMP IN LANDSCAPED AREA**  
**SETBACK > 5'**

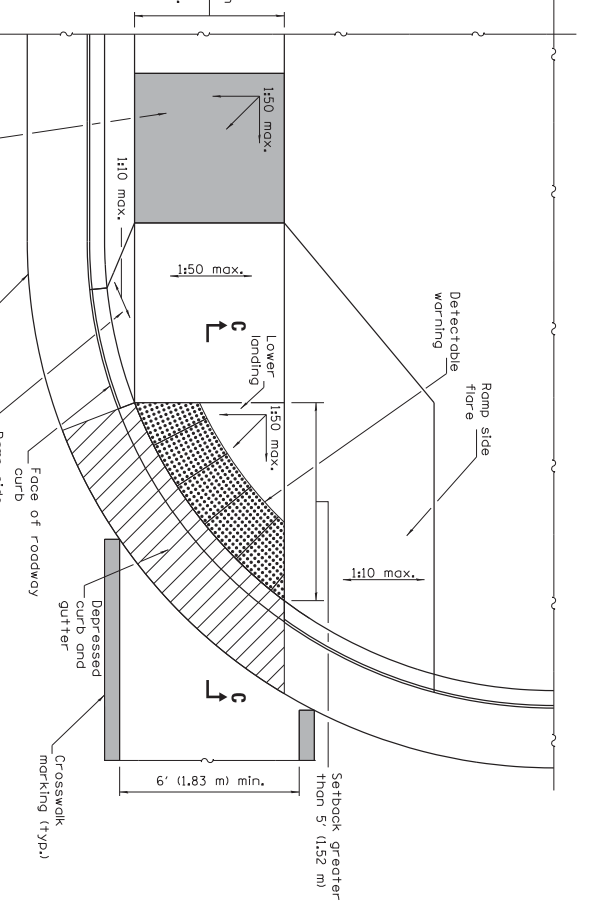

**RAMP IN PAVED AREA**  
**SETBACK > 5'**

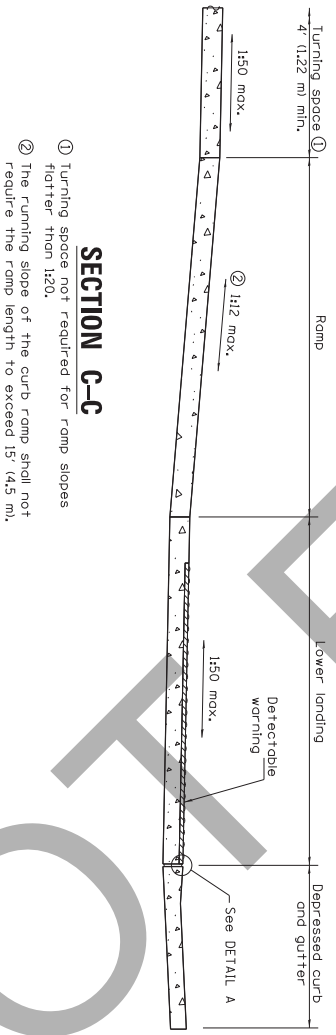

**SECTION C-C**

- ① Turning space not required for ramp slopes flatter than 1:20.
- ② The turning slope of the curb ramp shall not require the ramp length to exceed 15' (4.5 m).

**GENERAL NOTES**

All slope ratios are expressed as units of vertical displacement to units of horizontal displacement (V/H).

Where the turning space is constrained on a side opposite a ramp, the minimum length of the turning space in the direction of the ramp-run shall be 5' (1.52 m).

Where 1:50 maximum slope is shown, 1:64 is preferred.

See Standard 606001 for details of depressed curb adjacent to curb ramp.

All dimensions are in inches (millimeters) unless otherwise shown.

**PERPENDICULAR CURB RAMPS FOR SIDEWALKS**

STANDARD 424001-08

(Sheet 2 of 2)

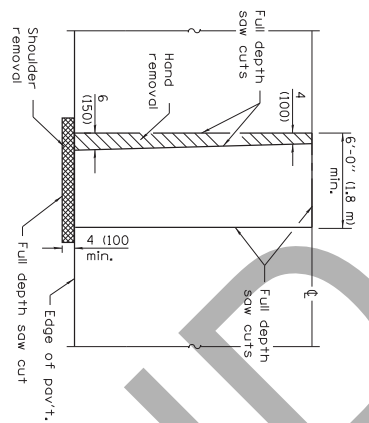

**PAVEMENT SAWING DETAIL**  
(HMA SHOULDER)

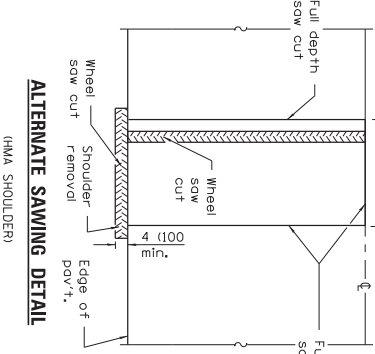

**ALTERNATE PAVEMENT SAWING DETAIL**  
(HMA SHOULDER)

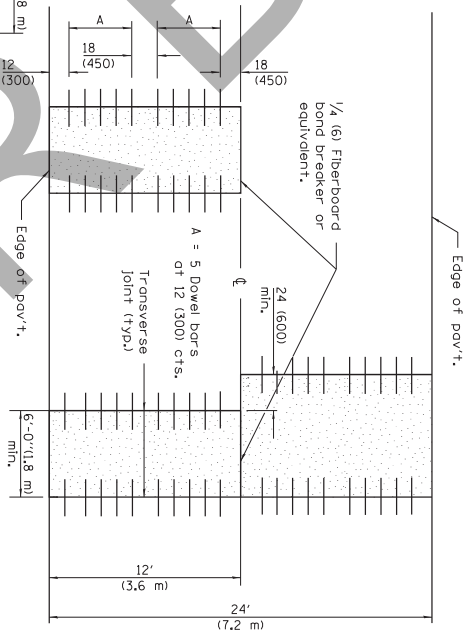

**12' (3.6 m) WIDE LANES**

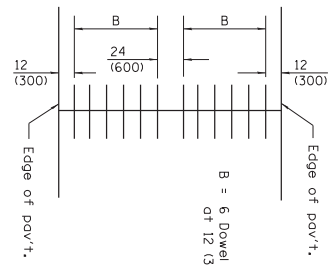

**14' (4.2 m) WIDE RAMP**

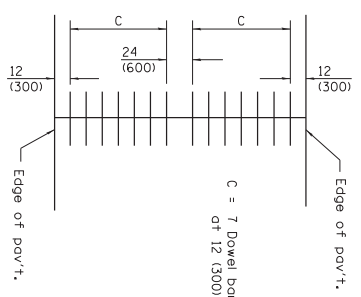

**16' (4.8 m) WIDE RAMP**

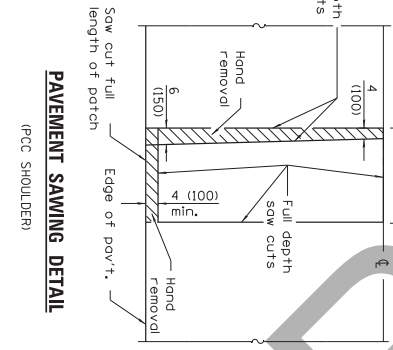

**PAVEMENT SAWING DETAIL**  
(PCC SHOULDER)

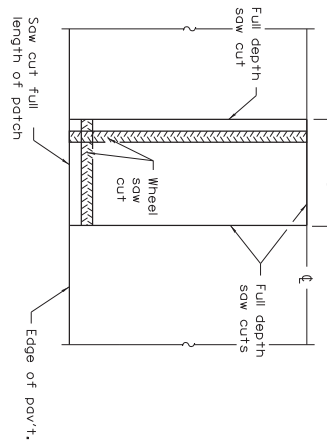

**ALTERNATE PAVEMENT SAWING DETAIL**  
(PCC SHOULDER)

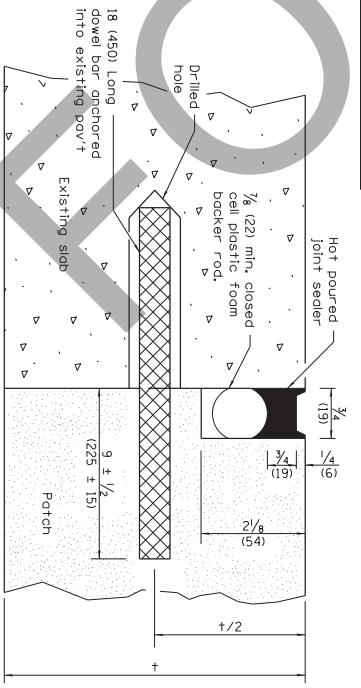

**TRANSVERSE JOINT**

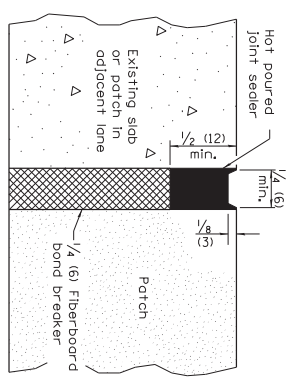

**CENTERLINE JOINT**

DOWEL BAR TABLE			
PAVEMENT THICKNESS	DOWEL BAR DIAMETER	HOLE DIAMETER	
8 (200) or greater	1 1/2 (38)	1 3/4 (41)	
7 (180) thru 7.99 (199)	1 1/4 (32)	1 3/8 (35)	
Less than 7 (180)	1 (25)	1 1/8 (29)	

**GENERAL NOTES**

The transverse joints for Class B patches shall align with joints or cracks in the adjacent lane whenever possible.  
See Standard 420701 for details of pavement fabric.  
All dimensions are in inches (millimeters) unless otherwise shown.

**CLASS B PATCHES**

STANDARD 442101-07  
(Sheet 1 of 2)

Illinois Department of Transportation  
 PASSED: January 1, 2008  
 ENGINEER OF POLICY AND PROCEDURES: [Signature]  
 APPROVED: January 1, 2008  
 ENGINEER OF DESIGN AND ENVIRONMENT: [Signature]

**TRANSVERSE EXPANSION JOINTS**

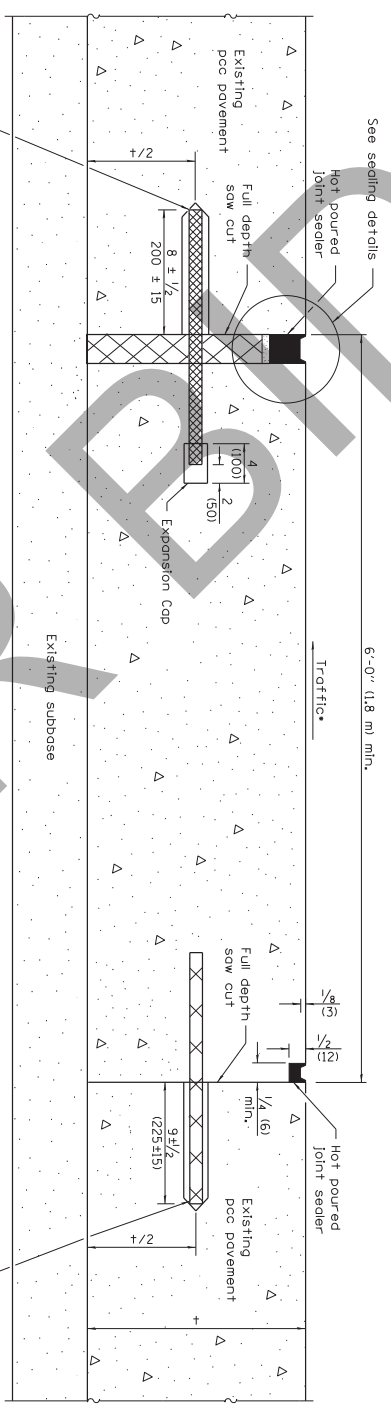

18 (450) Long dowel bars anchored into existing pavement at 12 (300) cts.

**METHOD I**  
(Without Resurfacing)

No. 10x18 (No. 32x450) The bars anchored into existing pavement at 12 (300) cts.

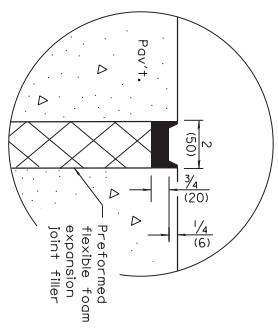

**SEALING DETAIL**

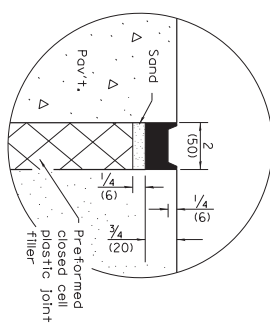

**SEALING DETAIL**

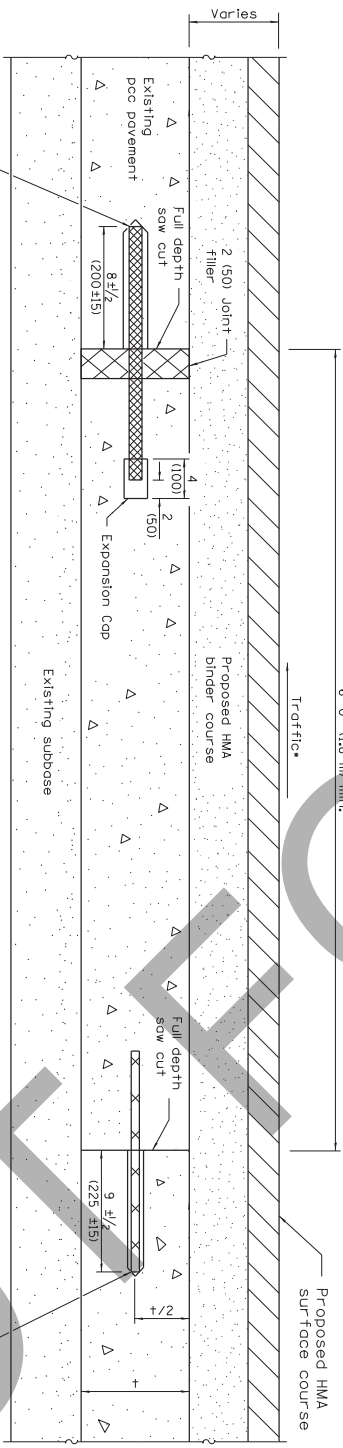

18 (450) Long dowel bars anchored into existing pavement at 12 (300) cts.

**METHOD II**  
(With Resurfacing)

**NOTE**

- When re-establishing a transverse expansion joint on a two-lane, two-way road, reverse the orientation of the dowel bars with respect to traffic for one of the patches such that the joint will be continuous across both lanes.

**CLASS B PATCHES**

STANDARD 442101-07

(Sheet 2 of 2)

Illinois Department of Transportation  
 PASSED: January 1, 2008  
 ENGINEER OF POLICY AND PROCEDURES: John S. Mo  
 APPROVED: January 1, 2008  
 ENGINEER OF DESIGN AND ENVIRONMENT: John S. Mo  
 ISSUED: 1-1-97

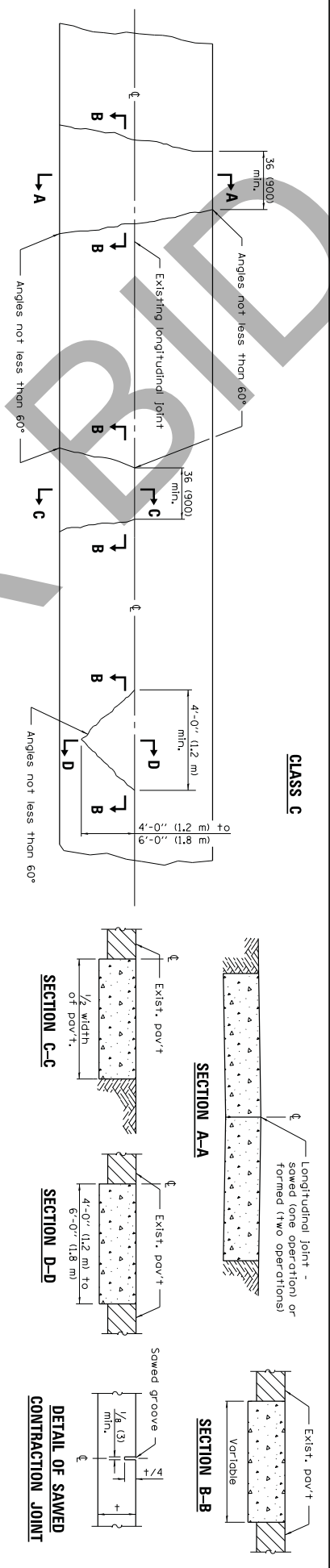

Notes:  
 Longitudinal joints shall be as detailed on Standard 422001, except the bars are not required for patches 20'-0" (6.0 m) or less in length.

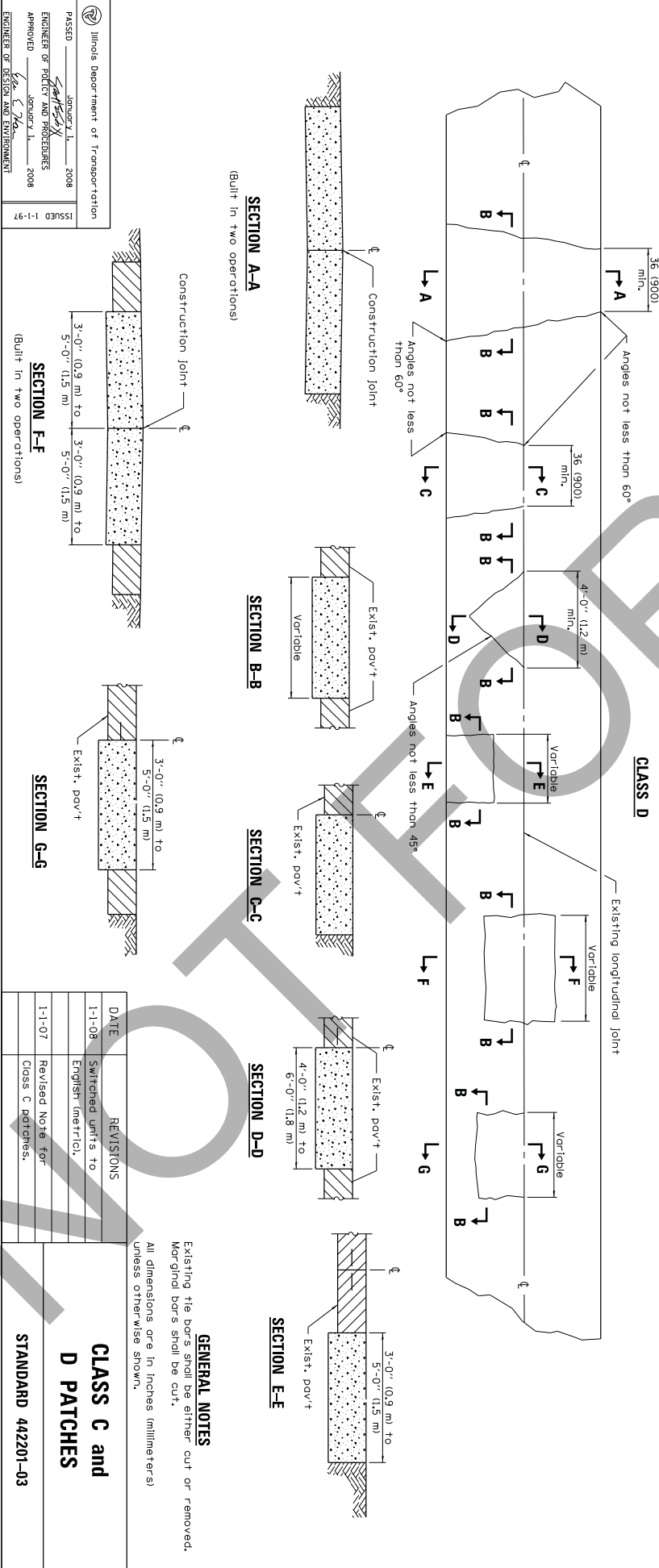

**GENERAL NOTES**  
 Existing the bars shall be either cut or removed. Marginal bars shall be cut.  
 All dimensions are in inches (millimeters) unless otherwise shown.

Illinois Department of Transportation  
 PASSED January 1, 2008  
 ENGINEER OF POLICY AND PROCEDURES  
 APPROVED January 1, 2008  
 ENGINEER OF DESIGN AND ENVIRONMENT  
 ISSUED 1-1-97

DATE	REVISIONS
1-1-08	Switched units to English (metric).
1-1-07	Revised Note for Class C patches.

**CLASS C and D PATCHES**  
 STANDARD 442201-03

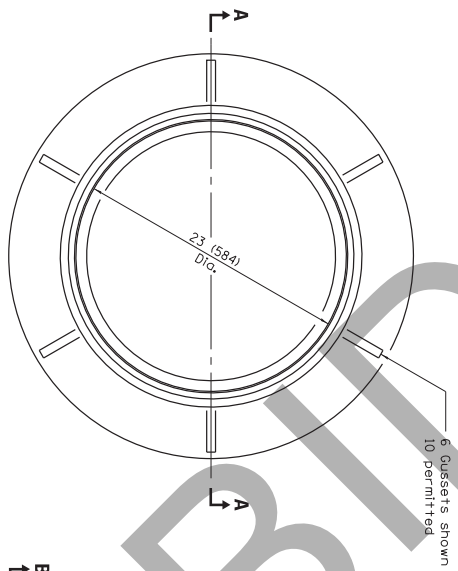

**CAST FRAME**

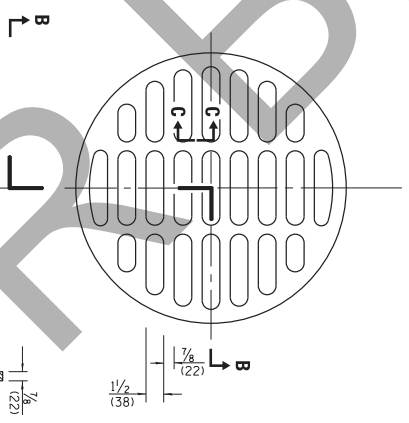

**SECTION C-C**

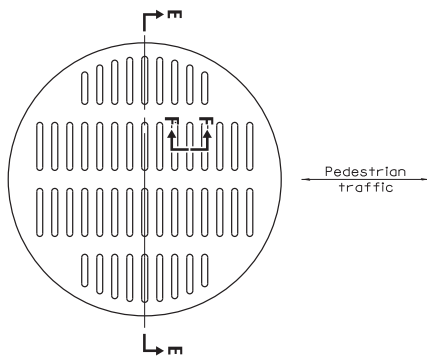

**SECTION E-E**

← Pedestrian traffic →

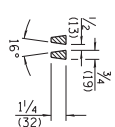

**SECTION F-F**

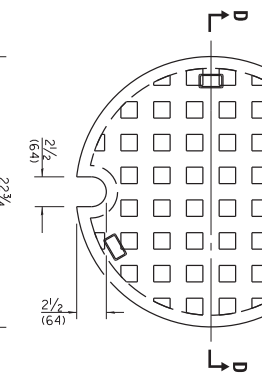

**SECTION D-D**

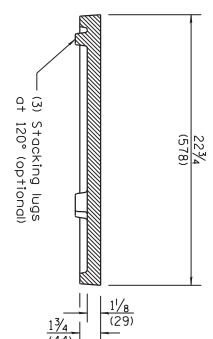

**SECTION B-B**

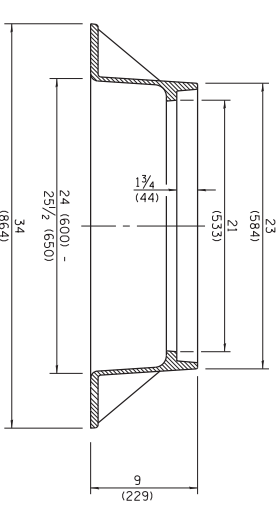

**SECTION A-A**

**CAST CLOSED LID**

**CAST OPEN LID**

**ADA COMPLIANT CAST OPEN LID**

All dimensions are in inches (millimeters) unless otherwise shown.

Illinois Department of Transportation  
 PASSED: *Michael Reed* January 1, 2015  
 ENGINEER OF PRACTICE AND PROCEDURES  
 APPROVED: *Michael Reed* January 1, 2015  
 ENGINEER OF DESIGN AND ENVIRONMENT  
 ISSUED: 1-1-97

DATE	REVISIONS
1-1-15	Revised dimensioning of frame. Added ADA compliance.
1-1-09	Switched units to English (metric).

**FRAME AND LIDS**  
**TYPE 1**  
**STANDARD 604001-04**

$\phi 5/8$  (10) Dia. hole and  $5/8 \times 5/2$  (16x140)  
 slotted hole for galvanized  $1/2$  (M12)  
 bolt, nut, and washer.  
 Curb box adjustable  
 from  $4 1/2$  (115) to  $9$  (225)

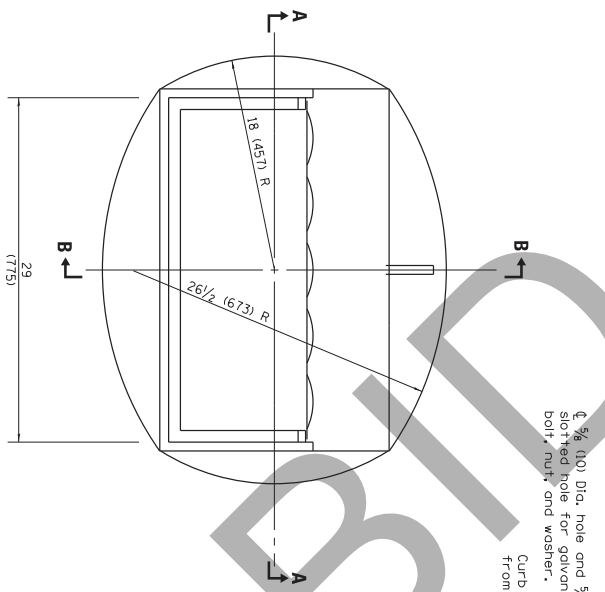

**CAST FRAME**

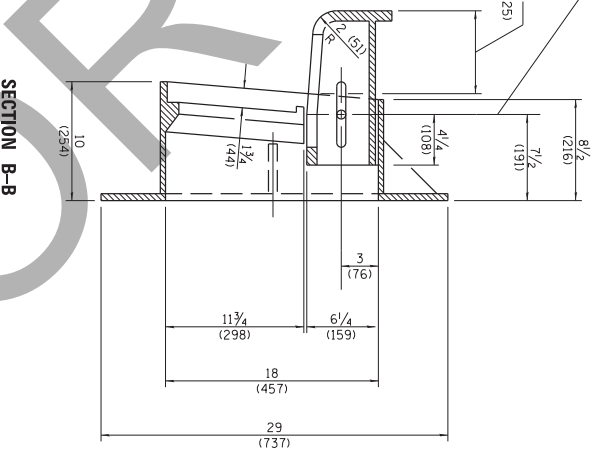

**SECTION B-B**

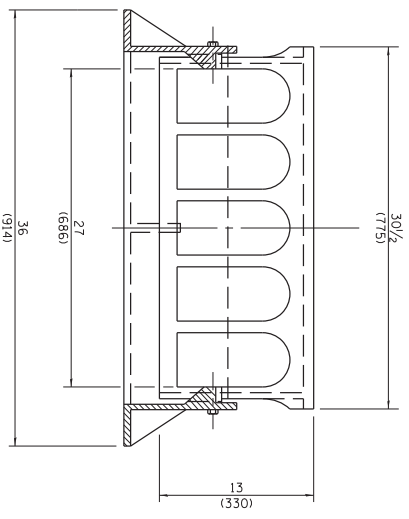

**SECTION A-A**

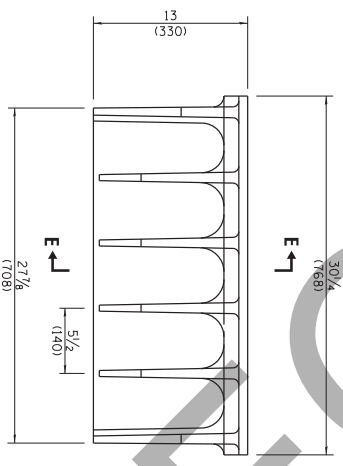

**ALTERNATE CURB BOX**

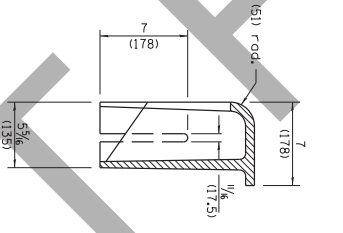

**SECTION E-E**

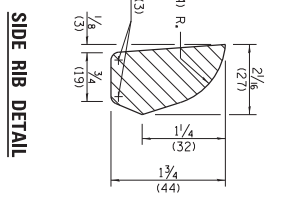

**SIDE RIB DETAIL**

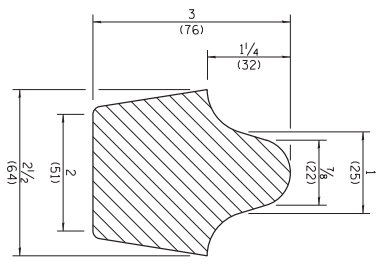

**MIDDLE RIB DETAIL**

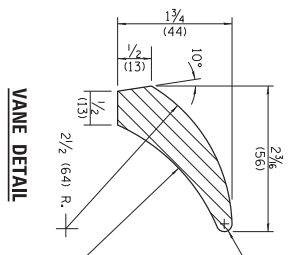

**VANE DETAIL**

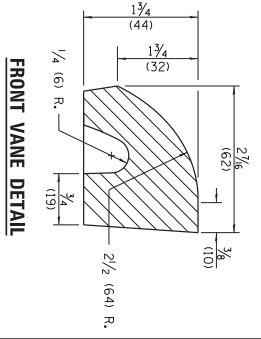

**FRONT VANE DETAIL**

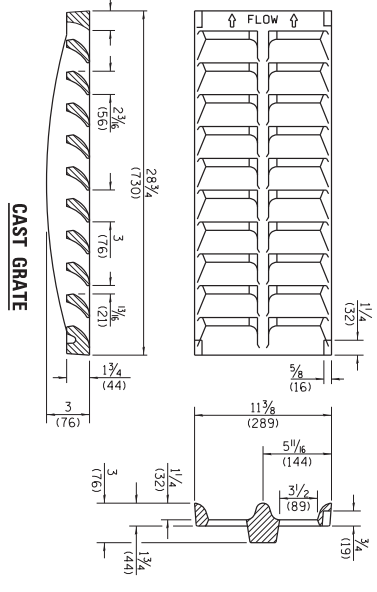

**CAST GRATE**

Illinois Department of Transportation  
 PASSED Michael Bond JANUARY 1, 2015  
 ENGINEER OF PORTICE AND PROCEEDURES  
 APPROVED [Signature] JANUARY 1, 2015  
 ENGINEER OF DESIGN AND ENVIRONMENT  
 ISSUED 1-1-97

DATE	REVISIONS
1-1-15	Revised dimensions of frame and alternate curb box.
1-1-09	Switched units to English metric.

**FRAME AND GRATE**  
**TYPE 11V**  
**STANDARD 60405-04**

All dimensions are in inches (millimeters) unless otherwise shown.

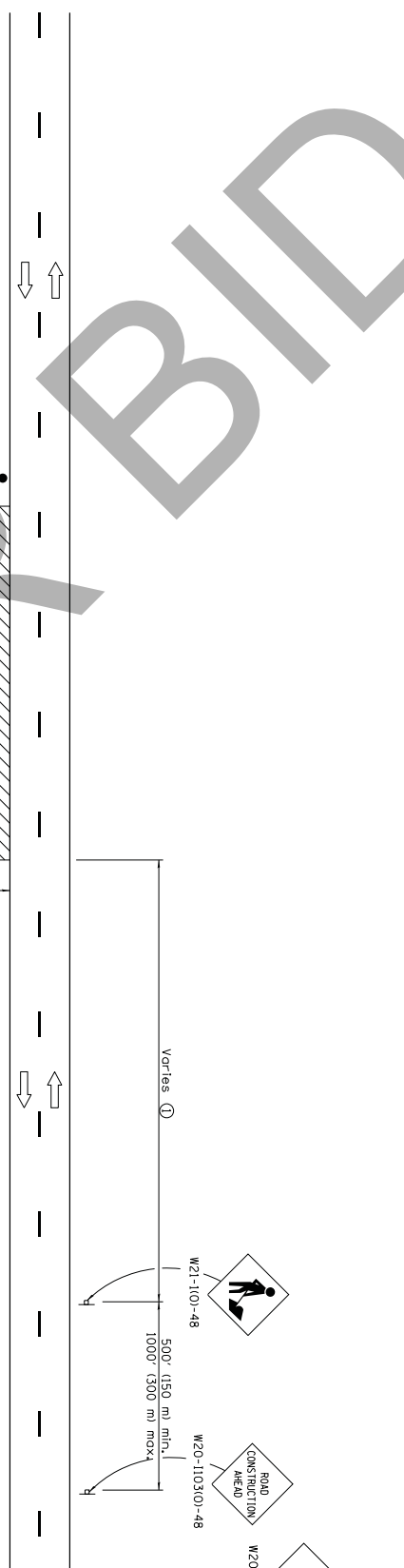

**TYPICAL APPLICATIONS**

Shoulder work  
Utility operations

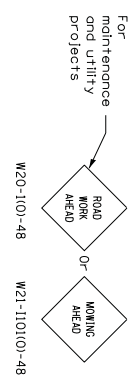

**SYMBOLS**



Work Area

- Sign
- Flagger with traffic control sign when required

① Minimum distance is 200'. (60 m). Maximum distance to be determined by the Engineer but should not exceed 1/2 the length required for one normal working day's operation, or 4 miles (6.4 km) whichever is less.

**GENERAL NOTES**

This Standard is used where at any time, any vehicle, equipment, workers or their activities require an intermittent or continuous moving operation on the shoulder, where the average speed is 1 mph (2 km/h) or less.

When the work operation does not exceed 60 minutes, traffic control may be according to Standard 701301.

All dimensions are in inches (millimeters) unless otherwise shown.

Illinois Department of Transportation

Approved: *Jonathan L. ...* January 1, 2014  
 ENGINEER OF SAFETY ENGINEERING

APPROVED: *Jonathan L. ...* January 1, 2014  
 ENGINEER OF DESIGN AND ENVIRONMENT

ISSUED 1-1-97

DATE	REVISIONS
1-1-14	Revised worker's sign number to agree with current MUTCD.
1-1-13	Omitted text "WORKERS" sign.

**OFF-RD MOVING OPERATIONS,  
21, 2W, DAY ONLY**

**STANDARD 701011-04**

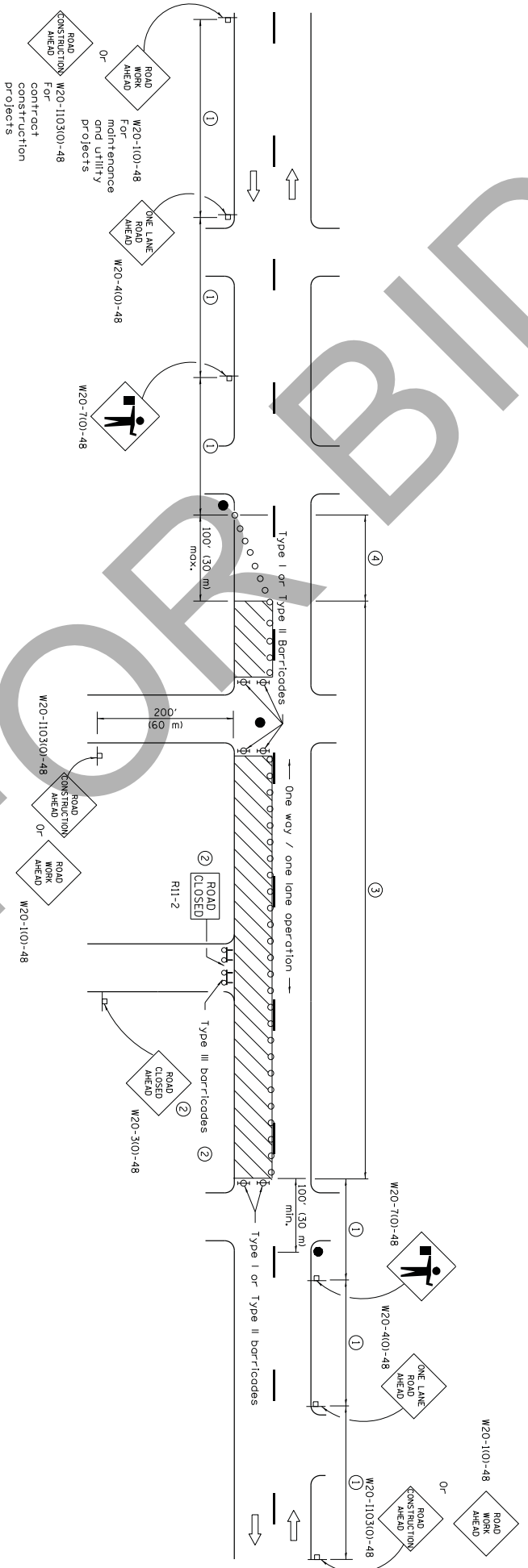

Posted Speed	Sign Spacing
55	500' (150 m)
50-45	350' (100 m)
<45	200' (60 m)

**SYMBOLS**

- Work area
- Cone, drum or barricade (not required for moving operations)
- Sign on portable or permanent support
- Flagger with traffic control sign
- Barricade or drum with flashing light
- Type III barricade with flashing lights

- 1 Refer to SIGN SPACING TABLE for distances.
- 2 For approved sideroad closures.
- 3 Cones of 25' (8 m) centers for 250' (75 m). Additional cones may be placed at 50' (15 m). Type I or Type II barricades are used. The interval between devices may be doubled.
- 4 Cones, drums or barricades of 20' (6 m) centers.

**GENERAL NOTES**

This Standard is used where at any time, day or night, any vehicle, equipment, workers or their activities on the pavement requiring the closure of one traffic lane in an urban area. All dimensions are in inches (millimeters) unless otherwise shown.

Illinois Department of Transportation  
 APPROVED January 1, 2011  
 ENGINEER OF SAFETY ENGINEERING  
 APPROVED January 1, 2011  
 ENGINEER OF DESIGN AND ENVIRONMENT

DATE	REVISIONS
1-1-11	Revised flagger sign.
1-1-09	Switched units to English (metric).
	Corrected sign No.s.

**URBAN LANE CLOSURE,  
 2L, 2W, UNDIVIDED**  
 STANDARD 701501-06

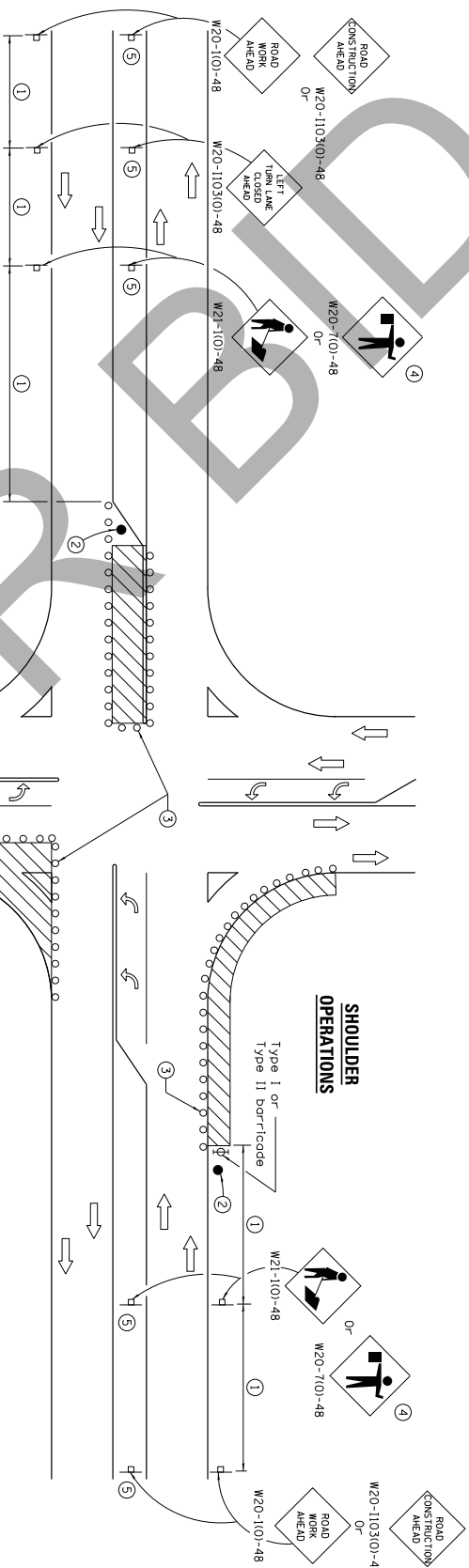

**LEFT TURN LANE OR CENTER MEDIAN OPERATIONS**

1 Refer to SIGN SPACING TABLE for distance.

2 Required for speed > 40 mph.

3 Cones at 25' (8 m) centers for 250' (75.50' (15 m) centers. When drums or Type II barricodes are used, the interval between devices may be doubled.

4 Use flagger sign only when flagger is present.

5 omit this sign when median is less than 10' (3 m) or for bi-directional turn lanes.

6 Cones, drums or barricodes at 20' (6 m) centers in taper.

7 Advanced arrow board required for speeds > 45 mph.

8 Three Type II barricodes, drums or vertical barricodes at 50' (15 m) centers.

SIGN SPACING			
Posted Speed	Sign Spacing	Sign Spacing	Sign Spacing
55	500' (150 m)	350' (100 m)	200' (60 m)
50-45			
<45			

**CORNER ISLAND OPERATIONS**

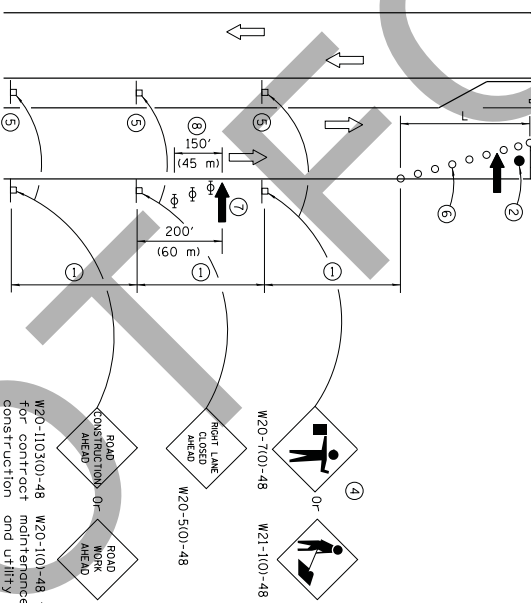

**SHOULDER OPERATIONS**

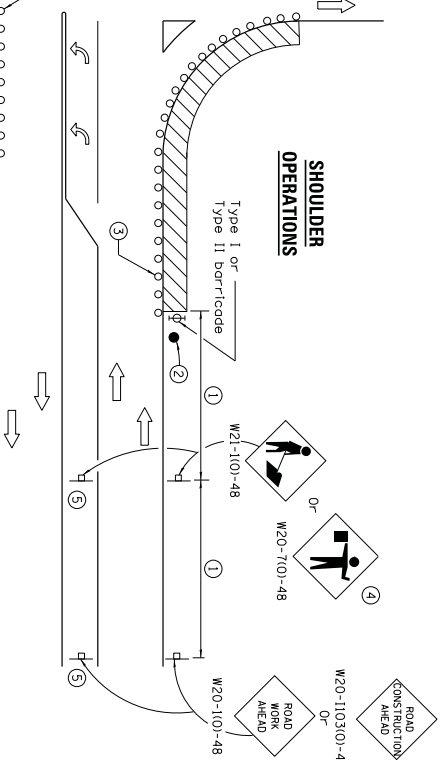

**SYMBOLS**

- Work area
- Cone, drum or barricode
- Sign on portable or permanent support
- Arrow board
- Barricade or drum with flashing light
- Flagger with traffic control sign

**GENERAL NOTES**

This Standard is used where at any time, day or night, any vehicle, equipment, workers or their activities encroach on the pavement during shoulder operations or where construction requires lane closures in an urban area.

Calculate L as follows:

**SPEED LIMIT**

English (Metric)  
40 mph (70 km/h) L = WS<sup>2</sup>  
or less: L = 150

45 mph (80 km/h) L=(WS)  
or greater:

W = Width of offset  
In feet (meters).

S = Normal posted speed  
mph (km/h).

All dimensions are in inches (millimeters) unless otherwise shown.

Illinois Department of Transportation  
 Approved: January 1, 2014  
 ENGINEER OF SAFETY ENGINEERING  
 APPROVED: January 1, 2014  
 ENGINEER OF DESIGN AND ENVIRONMENT  
 ISSUED 1-1-97

DATE	REVISIONS
1-1-14	Added devices at arrow board upstream from taper.
1-1-12	Rev. worker's sign number. Revised flagger sign. Omitted W21-1101 sign.

**URBAN LANE CLOSURE, MULTILANE INTERSECTION**  
**STANDARD 707101-09**

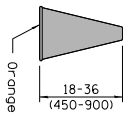

**CONE**

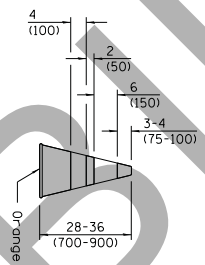

**REFLECTORIZED CONE**

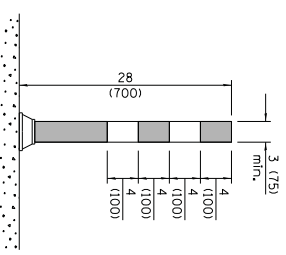

**FLEXIBLE DELINEATOR**

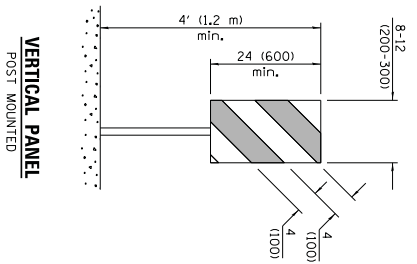

**VERTICAL PANEL  
POST MOUNTED**

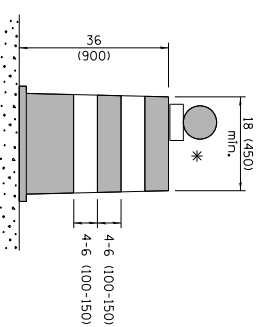

**DRUM**

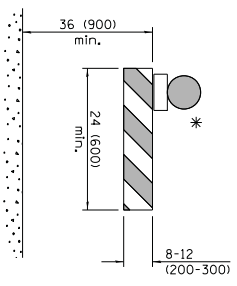

**TYPE I BARRICADE**

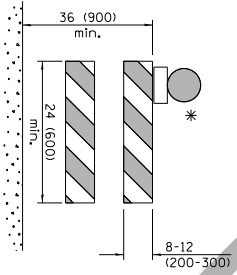

**TYPE II BARRICADE**

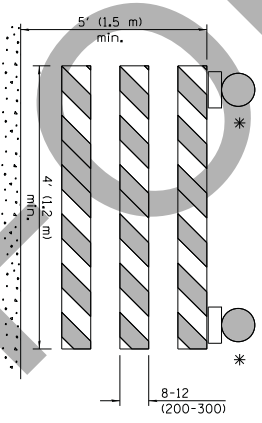

**TYPE III BARRICADE**

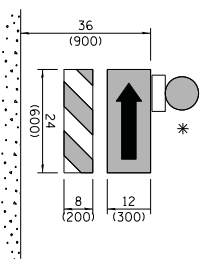

**DIRECTION INDICATOR  
BARRICADE**

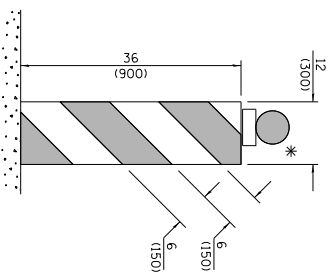

**VERTICAL BARRICADE**

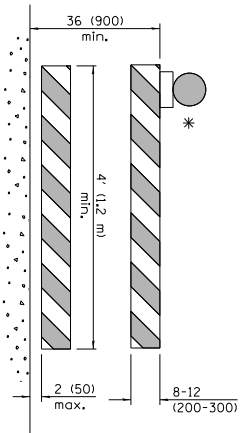

**DETECTABLE PEDESTRIAN  
CHANNELIZING BARRICADE**

\* Warning lights (if required)

**GENERAL NOTES**  
All heights shown shall be measured above the pavement surface.  
All dimensions are in inches (millimeters) unless otherwise shown.

Illinois Department of Transportation  
 Approved: [Signature] January 1, 2014  
 Engineer of Operations  
 Approved: [Signature] January 1, 2014  
 Engineer of Design and Environment  
 ISSUED 1-1-97

DATE	REVISIONS
1-1-14	Modified flagger sign height.
	Added highway construction speed zone signs.
1-1-12	Added detectable pedestrian channelizing barricade.

**TRAFFIC CONTROL DEVICES**  
 STANDARD 701901-03  
 (Sheet 1 of 3)

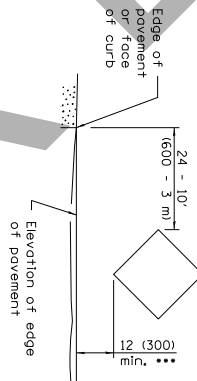
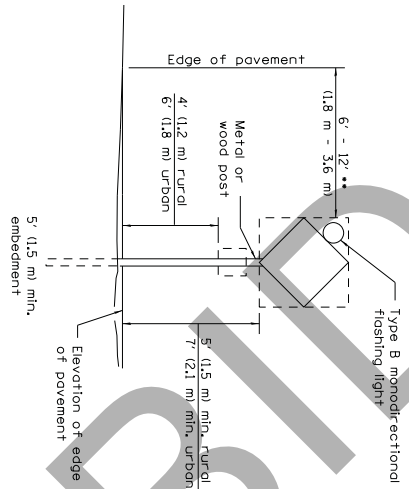

**SIGNS ON TEMPORARY SUPPORTS**

•• When work operations exceed four days, this dimension shall be 5' (1.5 m) min. If located behind other devices, the height shall be sufficient to be seen completely above the devices.

**POST MOUNTED SIGNS**

•• When curb or paved shoulder are present this dimension shall be 24 (600) to the face of curb or 6' (1.8 m) to the outside edge of the paved shoulder.

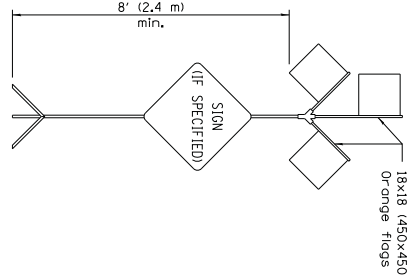

**HIGH LEVEL WARNING DEVICE**

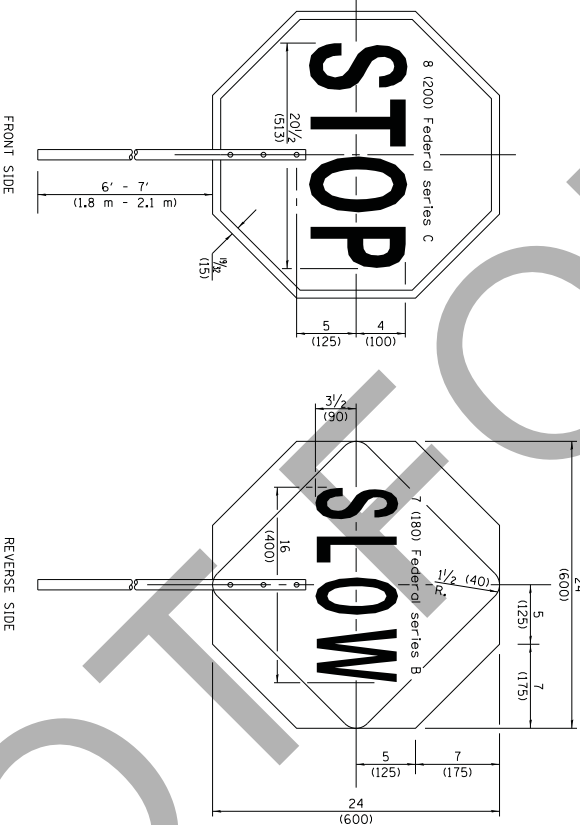

**FLAGGER TRAFFIC CONTROL SIGN**

Illinois Department of Transportation  
 APPROVED January 1, 2014  
 ENGINEER OF OPERATIONS  
 APPROVED January 1, 2014  
 ENGINEER OF DESIGN AND ENVIRONMENT  
 ISSUED 1-1-97

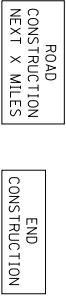

G20-1(0)-6036



G20-2d(0)-6024

This signing is required for all projects 2 miles (3200 m) or more in length. ROAD CONSTRUCTION NEXT X MILES sign shall be placed 500' (150 m) in advance of project limits. END CONSTRUCTION sign shall be erected at the end of the job unless another job is within 2 miles (3200 m). Dual sign displays shall be utilized on multi-lane highways.

**WORK LIMIT SIGNING**

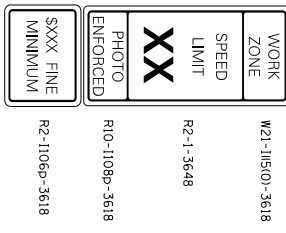

Sign assembly as shown on Standards or as allowed by District Operations.

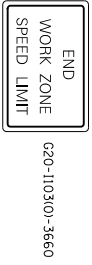

This sign shall be used when the above sign assembly is used.

**HIGHWAY CONSTRUCTION SPEED ZONE SIGNS**

**TRAFFIC CONTROL DEVICES**

STANDARD 701901-03

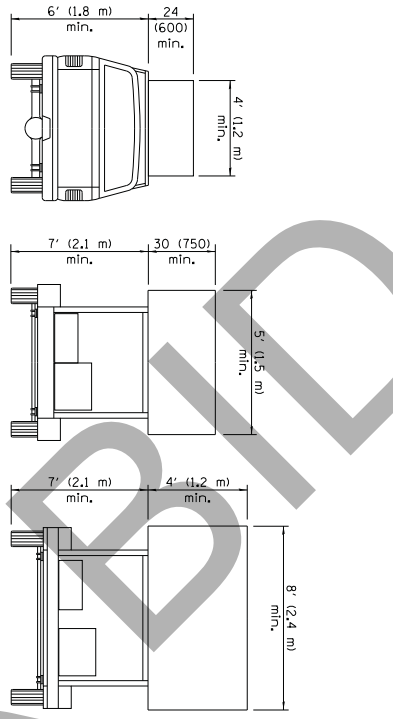

**TYPE A  
ROOF  
MOUNTED**

**TYPE B  
ROOF OR TRAILER  
MOUNTED**

**TYPE C  
TRAILER  
MOUNTED**

**ARROW BOARDS**

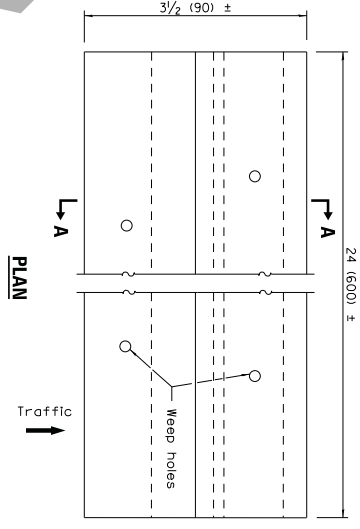

**PLAN**

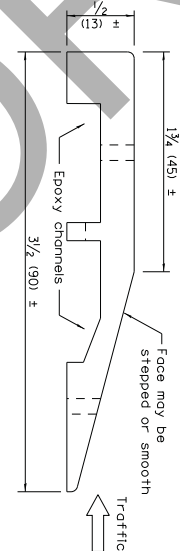

**SECTION A-A**

**TEMPORARY RUMBLE STRIPS**

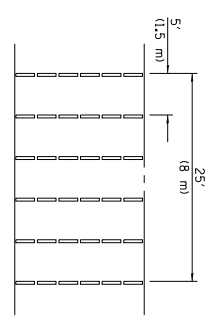
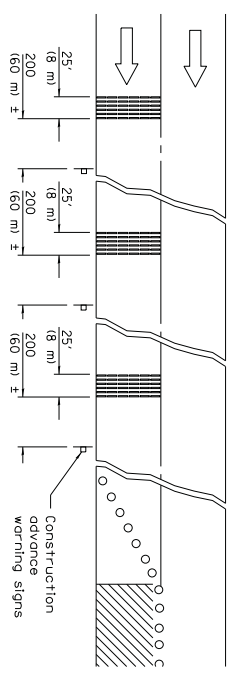

**TYPICAL INSTALLATION**

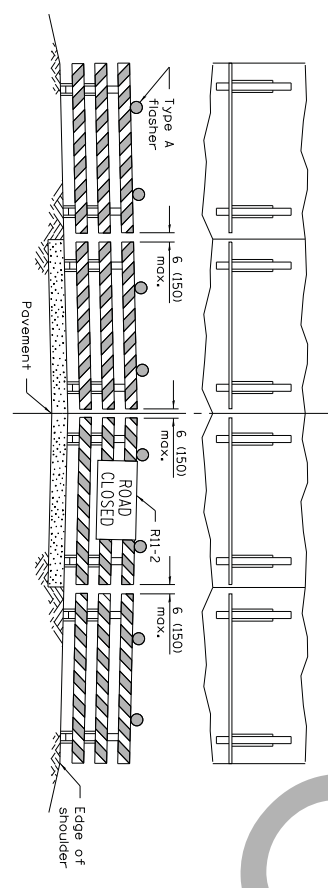

**ROAD CLOSED TO ALL TRAFFIC**

Reflectorized striping may be omitted on the back side of the barricades. If a Type III barricade with an attached sign panel which meets NCHRP 350 is not available, the sign may be mounted on an NCHRP 350 temporary sign support directly in front of the barricade.

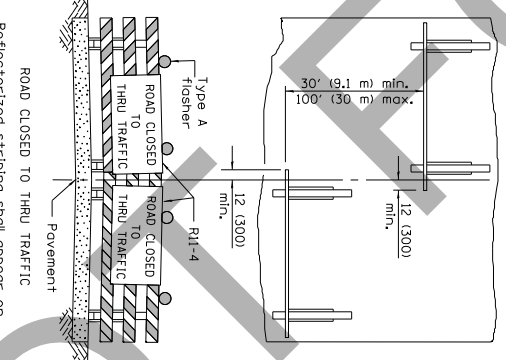

**ROAD CLOSED TO THRU TRAFFIC**

Reflectorized striping shall appear on both sides of the barricades. If a Type III barricade with an attached sign panel which meets NCHRP 350 is not available, the signs may be mounted on NCHRP 350 temporary sign supports directly in front of the barricade.

**TYPICAL APPLICATIONS OF  
TYPE III BARRICADES CLOSING A ROAD**

**TRAFFIC CONTROL  
DEVICES**

STANDARD 701901-03

(Sheet 3 of 3)

Illinois Department of Transportation  
 APPROVED: [Signature] January 1, 2014  
 ENGINEER/OF OPERATIONS  
 APPROVED: [Signature] January 1, 2014  
 ENGINEER OF DESIGN AND ENVIRONMENT  
 ISSUED 1-1-97

FOR BID

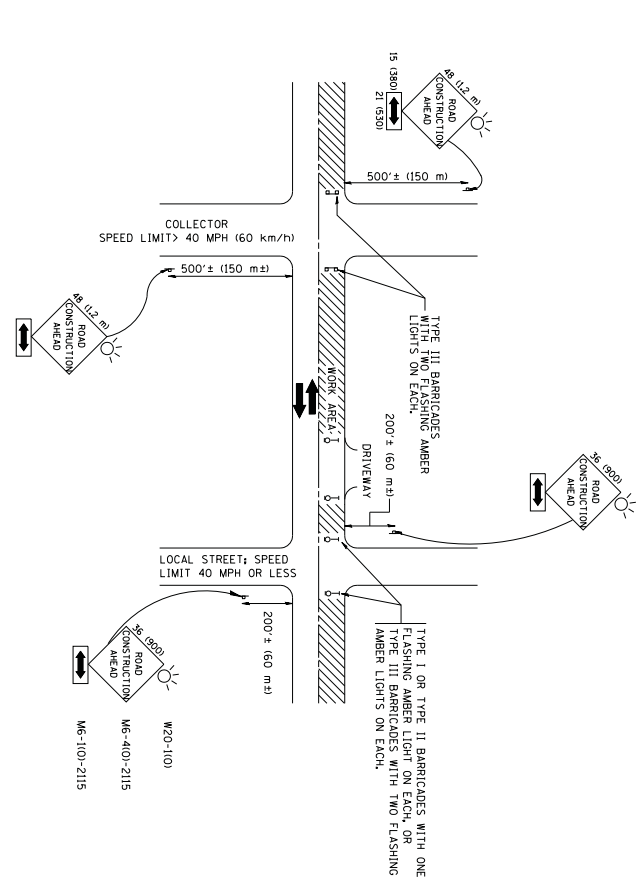

**TRAFFIC CONTROL AND PROTECTION FOR SIDE ROADS, INTERSECTIONS, AND DRIVEWAYS**

**NOTES:**

- A. FOR NO LANE RESTRICTION ON THE SIDE ROAD OR DRIVEWAYS
  - 1. SIDE ROAD WITH A SPEED LIMIT OF 40 MPH (60 km/h) OR LESS AS SHOWN ON THE DRAWING AND AS DIRECTED BY THE ENGINEER
  - o ONE **ROAD CONSTRUCTION AHEAD** SIGN, 36" x 56" (900x900) WITH A FLASHER AND FLAG MOUNTED ON IT APPROXIMATELY 200' (60 m) IN ADVANCE OF THE MAIN ROUTE.
  - b) THE CLOSED PORTION OF THE MAIN ROUTE SHALL BE PROTECTED BY BLOCKING WITH TYPE I, TYPE II OR TYPE III BARRICADES, 1/3 OF THE CROSS SECTION OF THE CLOSED PORTION.
  - 2. SIDE ROAD WITH A SPEED LIMIT GREATER THAN 40 MPH (60 km/h) AS SHOWN ON THE DRAWING AND AS DIRECTED BY THE ENGINEER
    - o ONE **ROAD CONSTRUCTION AHEAD** SIGN, 48" x 48" (122 cm x 122 cm) WITH A FLASHER AND FLAG MOUNTED ON IT APPROXIMATELY 200' (60 m) IN ADVANCE OF THE MAIN ROUTE.
    - b) THE CLOSED PORTION OF THE MAIN ROUTE SHALL BE PROTECTED BY BLOCKING WITH TYPE III BARRICADES, 1/2 OF THE CROSS SECTION OF THE CLOSED PORTION.
    - 3. WHEN THE SIDE ROAD LIES BETWEEN THE BEGINNING OF THE MAINLINE SLOPING AND THE WORK ZONE, A SINGLE HEADED ARROW (M6-11) SHALL BE USED IN LIEU OF THE DOUBLE HEADED ARROW (M6-9).
- B. FOR A LANE CLOSURE ON A SIDE ROAD OR DRIVEWAY
  - USE APPLICABLE PORTIONS OF THE TYPICAL APPLICATION OF TRAFFIC CONTROL DEVICES (STD. 709.01, STD. 709.02, OR THE APPROPRIATE STANDARD) AS DIRECTED BY THE ENGINEER. THE DIRECTIONAL ARROW SHALL BE COVERED OR REMOVED WHEN NO LONGER CONSISTENT WITH THE SIDE ROAD LANE CLOSURE.
  - C. ADVANCE WARNING SIGNS ARE TO BE OMITTED ON DRIVEWAY UNLESS OTHERWISE NOTED.
  - D. THE TRAFFIC CONTROL AND PROTECTION FOR SIDE ROADS, INTERSECTIONS, AND DRIVEWAYS SHALL BE SUBJECT TO THE COST OF SPECIFIED TRAFFIC CONTROL STANDARDS OF ITEMS.

FILE NAME *	K:\work\12-24\12\12.dgn		
USER NAME *	sgajdos	DESIGNED -	LJA
PLOT SCALE *	8.0000 / IN	DRAWN -	
PLOT DATE *	1/14/2008	CHECKED -	
		DATE -	06-03
		REVISED -	J. OBERNIE 10-18-95
		REVISED -	A. HOUSER 03-06-96
		REVISED -	A. HOUSER 10-16-96
		REVISED -	T. RAMMACHER 01-06-00

**STATE OF ILLINOIS  
DEPARTMENT OF TRANSPORTATION**

<b>TRAFFIC CONTROL AND PROTECTION FOR SIDE ROADS, INTERSECTIONS, AND DRIVEWAYS</b>	SCALE: NONE	SHEET NO. 1 OF 1 SHEETS, 11A TO 11A
DATE: 1/14/2008	SECTION: TE-10	COUNTY: [ ] SHEETS: [ ]
CONTRACT NO.:	CONTRACT NO.:	CONTRACT NO.:

All dimensions are in millimeter's (Inches) unless otherwise shown.

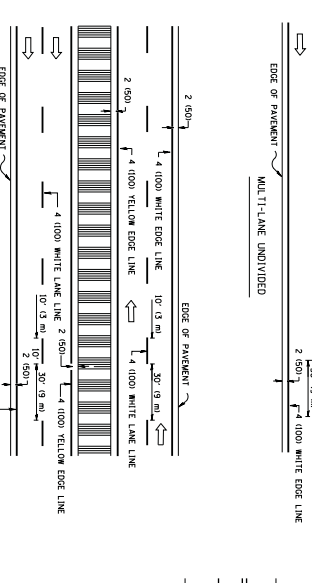
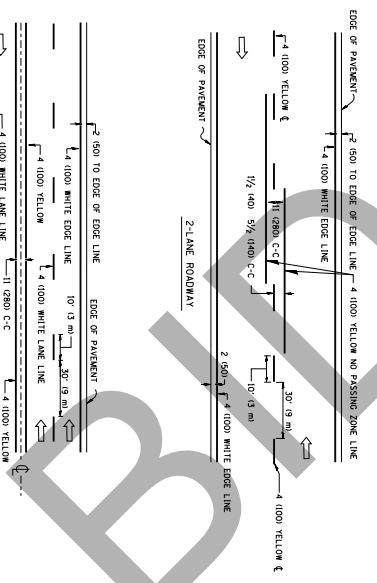

TYPICAL LANE AND EDGE LINE MARKING

NOTE: MEDIANS WITH BARRIER CURBS DO NOT REQUIRE AN EDGE LINE

TYPICAL CROSSWALK MARKING

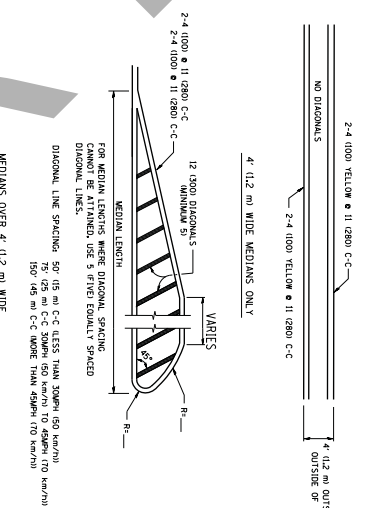
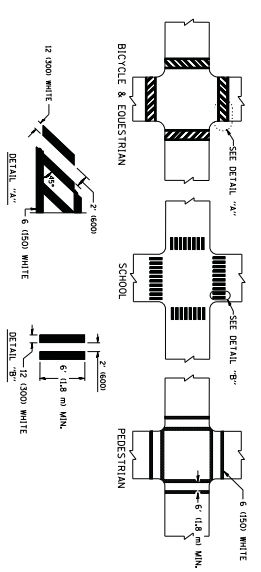

TYPICAL PAINTED MEDIAN MARKING

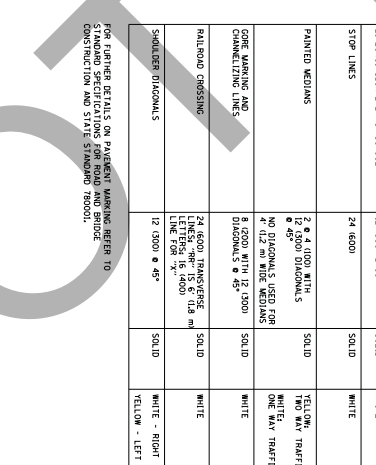
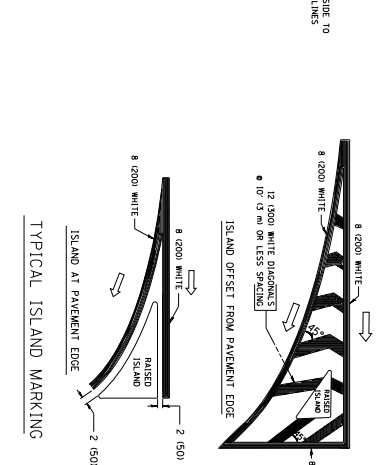
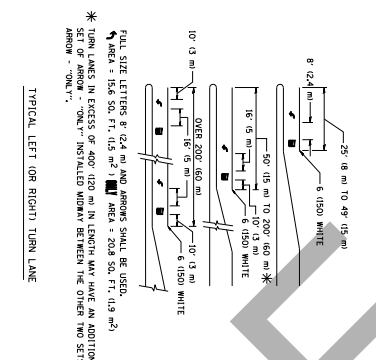

TYPICAL TURN LANE MARKING

FILE NAME	USER NAME	DESIGNED	REVISIONS
PROJECT	LOT SCALE	DRAWN	CHECKED
DATE	DATE	DATE	DATE

STATE OF ILLINOIS  
DEPARTMENT OF TRANSPORTATION

DISTRICT ONE  
TYPICAL PAVEMENT MARKINGS

SCALE NONE	SHEET NO. 1 OF 1	SHEETS MARKINGS	TO STA.
FILE	SECTION	COUNTY	TOTAL SHEETS
TE-13			

TYPE OF MARKING	METHOD OF LINE	PATTERN	COLOR	SPACING / REMARKS
CENTERLINE ON 2-LANE PAVEMENT	4 (1000)	SPR-DASH	YELLOW	10' (3 m) LINE WITH 30' (9 m) SPACE
CENTERLINE ON MULTI-LANE UNDIVIDED PAVEMENT	2 (4 (1000)	SOLID	YELLOW	11 (280) C-C
NO PASSING ZONE LINES	4 (1000)	SOLID	YELLOW	5 (120) C-C FROM SPR-DASH CENTERLINE
NO PASSING ZONE LINES FOR ONE DIRECTION	4 (1000)	SPR-DASH	YELLOW	10' (3 m) LINE WITH 30' (9 m) SPACE
LANE LINES	4 (1000) OR INTERMITS	SPR-DASH	WHITE	10' (3 m) LINE WITH 30' (9 m) SPACE
GOITTED LINES FOR CENTER, LANE OR TURN LANE MARKINGS	4 (1000)	SPR-DASH	WHITE	2' (600) LINE WITH 6' (1.8 m) SPACE
TURN LANE MARKINGS	6 (150) LINE FULL SIZE LETTERS 6 (150)	SOLID	WHITE	SEE TYPICAL TURN LANE MARKING DETAIL
TWO WAY LEFT TURN MARKING	2 (4 (1000) EACH DIRECTION	SPR-DASH AND SOLID	YELLOW	10' (3 m) LINE WITH 30' (9 m) SPACE FOR SOLID AND SPR-DASH CENTERLINE
PROGRESSIVE LINES (PEDESTRIAN & BICYCLE) WITH 12 (3000) C-C	2 (6 (1500) SOLID	SOLID	WHITE	NOT LESS THAN 6' (1.8 m) APART
PROGRESSIVE LINES (PEDESTRIAN & BICYCLE) WITH 12 (3000) C-C	2 (6 (1500) SOLID	SOLID	WHITE	NOT LESS THAN 6' (1.8 m) APART
PROGRESSIVE LINES (PEDESTRIAN & BICYCLE) WITH 12 (3000) C-C	2 (6 (1500) SOLID	SOLID	WHITE	NOT LESS THAN 6' (1.8 m) APART
PAINTED MEDIANS	2 (4 (1000) WITH NO DIAGONALS	SOLID	YELLOW	SEE TYPICAL PAINTED MEDIAN MARKING.
CROSSWALK MARKING	NO DIAGONALS USED FOR CROSSWALKS	SOLID	WHITE	SEE TYPICAL CROSSWALK MARKING DETAIL.
RAILROAD CROSSING	24 (600) TRANSVERSE LINES WITH 15 (375) C-C	SOLID	WHITE	SEE TYPICAL RAILROAD CROSSING DETAIL.
SCHOOLER DIAGONALS	12 (3000) & 45'	SOLID	YELLOW - LEFT	SEE TYPICAL SCHOOLER DETAIL.

FOR LARGER DETAILS ON PAVEMENT MARKING REFER TO STANDARD SPECIFICATIONS FOR ROAD AND BRIDGE CONSTRUCTION AND STATE STANDARD TR80001.

At discretion of the Illinois Department of Transportation, unless otherwise shown.

NOT FOR BID

**APPENDIX**

**A**

NOT FOR BID

NOT FOR BID

# IRMA CONTRACTUAL INSURANCE GUIDELINES

## I. INSURANCE REQUIREMENTS

Contractor shall procure and maintain, for the duration of the contract, insurance against claims for injuries to persons or damages to property, which may arise from or in connection with the performance of the work hereunder by the Contractor, his agents, representatives, employees or subcontractors.

### MINIMUM SCOPE OF INSURANCE

Coverage shall be at least as broad as:

- A. Insurance Services Office Commercial General Liability occurrence form CG 0001 with the member named as additional insured, on a form at least as broad as the attached sample endorsement including ISO Additional Insured Endorsement CG 2010 (Exhibit A), CG 2026 (Exhibit B).

**CG2037 - Completed Operations – (Exhibit C)**

**Required if box is checked**  ; and

- B. Owners and Contractors Protective Liability (OCP) policy with the member as insured

**Required if box is checked**  ; and

- C. Insurance Service Office Business Auto Liability coverage form number CA 0001, Symbol 01 "Any Auto."

- D. Workers' Compensation as required by the Workers' Compensation Act of the State of Illinois and Employers' Liability insurance.

**Coverage required for employee exposure to lead, if box is checked**

- E. Builder Risk Property Coverage with member as loss payee

**Required if box is checked** .

- F. Environmental Impairment/Pollution Liability Coverage for pollution incidents as a result of a claim for bodily injury, property damage or remediation costs from an incident at, on or migrating beyond the contracted work site. Coverage shall be extended to Non-Owned Disposal sites resulting from a pollution incident at, on or mitigating beyond the site; and also provide coverage for incidents occurring during transportation of pollutants.

**Required if box is checked** .

### MINIMUM LIMITS OF INSURANCE

Contractor shall maintain limits no less than the following, **if required under above scope**:

- A. Commercial General Liability: \$1,000,000 combined single limit per occurrence for bodily injury, and property damage and \$1,000,000 per occurrence for personal injury. The general aggregate shall be twice the required occurrence limit. Minimum General Aggregate shall be no less than \$2,000,000 or a project/contract

specific aggregate of \$1,000,000.

- B. Owners and Contractors Protective Liability (OCP): \$1,000,000 combined single limit per occurrence for bodily injury and property damage.
- C. Business Automobile Liability: \$1,000,000 combined single limit per accident for bodily injury and property damage.
- D. Workers' Compensation and Employers' Liability: Workers' Compensation coverage with statutory limits and Employers' Liability limits of \$500,000 per accident.
- E. Builder's Risk: Shall insure against "All Risk" of physical damage, including water damage (flood and hydrostatic pressure not excluded), on a completed replacement cost basis.
- F. Environmental Impairment/Pollution Liability: \$1,000,000 combined single limit per occurrence for bodily injury, property damage and remediation costs.

### **DEDUCTIBLES AND SELF-INSURED RETENTIONS**

Any deductibles or self-insured retentions must be declared to and approved by the member. At the option of the member, either: the insurer shall reduce or eliminate such deductibles or self-insured retentions as respects the member, its officials, employees, agents and volunteers; or the Contractor shall procure a bond guaranteeing payment of losses and related investigation, claim administration and defense expenses.

### **OTHER INSURANCE PROVISIONS**

The policies are to contain, or be endorsed to contain, the following provisions:

#### **A. General Liability and Automobile Liability Coverages**

1. The member, its officials, agents, employees and volunteers are to be covered as additional insureds as respects: liability arising out of the Contractor's work, including activities performed by or on behalf of the Contractor; products and completed operations of the Contractor; premises owned, leased or used by the Contractor; or automobiles owned, leased, hired or borrowed by the Contractor. The coverage shall contain no special limitations on the scope of protection afforded to the member, its officials, agents, employees and volunteers.
2. The Contractor's insurance coverage shall be primary as respects the member, its officials, employees, agents and volunteers. Any insurance or self-insurance maintained by the member, its officials, agents, employees and volunteers shall be excess of Contractor's insurance and shall not contribute with it.
3. Any failure to comply with reporting provisions of the policies shall not affect coverage provided to the member, its officials, employees, agents and volunteers.
4. The Contractor's insurance shall contain a Severability of Interests/Cross Liability clause or language stating that Contractor's insurance shall apply

separately to each insured against whom claim is made or suit is brought, except with respect to the limits of the insurer's liability.

5. If any commercial general liability insurance is being provided under an excess or umbrella liability policy that does not "follow form," then the Contractor shall be required to name the member, its officials, employees, agents and volunteers as additional insureds.
6. All general liability coverages shall be provided on an occurrence policy form. Claims-made general liability policies will not be accepted.
7. The contractor and all subcontractors hereby agree to waive any limitation as to the amount of contribution recoverable against them by member. This specifically includes any limitation imposed by any state statute, regulation, or case law including any Workers' Compensation Act provision that applies a limitation to the amount recoverable in contribution such as Kotecki v. Cyclops Welding.

**B. Workers' Compensation and Employers' Liability Coverage**

The insurer shall agree to waive all rights of subrogation against the member, its officials, employees, agents and volunteers for losses arising from work performed by Contractor for the municipality.

1. NCCI Alternate Employer Endorsement (WC 000301) in place to insure that workers' compensation coverage applies under contractor's coverage rather than member's if the member is borrowing, leasing or in day to day control of contractors employee.

**Required if box is checked** .

**C. Professional Liability (Required if box is checked  )**

1. Professional liability insurance with limits not less than \$1,000,00 each claim with respect to negligent acts, errors and omissions in connection with professional services to be provided under the contract, with a deductible not-to-exceed \$50,000 without prior written approval.
2. If the policy is written on a claims-made form, the retroactive date must be equal to or preceding the effective date of the contract. In the event the policy is cancelled, non-renewed or switched to an occurrence form, the Contractor shall be required to purchase supplemental extending reporting period coverage for a period of not less than three (3) years.
3. Provide a certified copy of actual policy for review.
4. Recommended Required Coverage (architect, engineer, surveyor, consultant): Professional liability insurance that provides indemnification and defense for injury or damage arising out of acts, errors, or omissions in providing the following professional services, but not limited to the following:
  - a. Preparing, approving or failure to prepare or approve maps, drawings, opinions, report, surveys, change orders, designs or specifications;
  - b. Providing direction, instruction, supervision, inspection, engineering

services or failing to provide them, if that is the primary cause of injury or damage.

**D. All Coverages**

Each insurance policy required shall have the member expressly endorsed onto the policy as a Cancellation Notice Recipient. Should any of the policies be cancelled before the expiration date thereof, notice will be delivered in accordance with the policy provisions.

**ACCEPTABILITY OF INSURERS**

Insurance is to be placed with insurers with a Best's rating of no less than A-, VII and licensed to do business in the State of Illinois.

**VERIFICATION OF COVERAGE**

Contractor shall furnish the member with certificates of insurance naming the member, its officials, employees, agents and volunteers as additional insureds (Exhibit D), and with original endorsements affecting coverage required by this clause. The certificates and endorsements for each insurance policy are to be signed by a person authorized by that insurer to bind coverage on its behalf. The certificates and endorsements are to be received and approved by the member before any work commences. The following additional insured endorsements may be utilized: ISO Additional Insured Endorsements CG 2010 (Exhibit A) or CG 2026 (Exhibit B), and CG 2037 (Exhibit C) – Completed Operations, where required. The member reserves the right to request full certified copies of the insurance policies and endorsements.

**SUBCONTRACTORS**

Contractor shall include all subcontractors as insureds under its policies or shall furnish separate certificates and endorsements for each subcontractor. All coverages for subcontractors shall be subject to all of the requirements stated herein.

**ASSUMPTION OF LIABILITY**

The contractor assumes liability for all injury to or death of any person or persons including employees of the contractor, any sub-contractor, any supplier or any other person and assumes liability for all damage to property sustained by any person or persons occasioned by or in any way arising out of any work performed pursuant to this agreement.

**II. INDEMNITY/HOLD HARMLESS PROVISION**

To the fullest extent permitted by law, the Contractor hereby agrees to defend, indemnify and hold harmless the member, its officials, employees and agents against all injuries, deaths, loss, damages, claims, patent claims, suits, liabilities, judgments, cost and expenses, which may in anywise accrue against the member, its officials, agents and employees, arising in whole or in part or in consequence of the performance of this work by the Contractor, its employees, or subcontractors, or which may in anywise result therefore, except that arising out of the sole legal cause of the member, its employees or agents, the Contractor shall, at its own expense, appear, defend and pay all charges of attorneys and all costs and other expenses arising therefore or incurred in connections

therewith, and, if any judgment shall be rendered against the member, its officials, employees and agents, in any such action, the Contractor shall, at its own expense, satisfy and discharge the same.

Contractor expressly understands and agrees that any performance bond or insurance policies required by this contract, or otherwise provided by the Contractor, shall in no way limit the responsibility to indemnify, keep and save harmless and defend the member, its officials, employees and agents as herein provided.

The Contractor further agrees that to the extent that money is due the Contractor by virtue of this contract as shall be considered necessary in the judgment of the member, may be retained by the member to protect itself against said loss until such claims, suits, or judgments shall have been settled or discharged and/or evidence to that effect shall have been furnished to the satisfaction of the member.

### III. **SAFETY/LOSS PREVENTION**

#### **Safety/Loss Prevention Program Requirements**

- Successful bidder will provide written confirmation that a safety/loss prevention program was in place at least 90 days prior to submitting the bid proposal.
- Evidence of completed employee safety training can be provided.

#### **Regulatory Requirements**

- Successful bidder must comply with all applicable laws, regulations, and rules promulgated by any Federal, State, County, Municipal and/or other governmental unit or regulatory body now in effect or which may be in effect during the performance of the work. Included within the scope of the laws, regulations, and rules referred to in this paragraph but in no way to operate as a limitation, are Occupational Safety & Health Act (OSHA), Illinois Department of Labor (IDOL), Department of Transportation, all forms of traffic regulations, public utility, Intrastate and Interstate Commerce Commission regulations, Workers' Compensation Laws, Prevailing Wage Laws, the Social Security Act of the Federal Government and any of its titles, the Illinois Department of Human Rights, Human Rights Commission, or EEOC statutory provisions and rules and regulations.
- Evidence of specific regulatory compliance will be provided by bidder, if required by owner.

NOT FOR BID

EXHIBIT A

POLICY NUMBER:

COMMERCIAL GENERAL LIABILITY  
CG 20 10 07 04

THIS ENDORSEMENT CHANGES THE POLICY. PLEASE READ IT CAREFULLY.

**ADDITIONAL INSURED – OWNERS, LESSEES OR  
CONTRACTORS – SCHEDULED PERSON OR  
ORGANIZATION**

This endorsement modifies insurance provided under the following:

COMMERCIAL GENERAL LIABILITY COVERAGE PART

SCHEDULE

Name Of Additional Insured Person(s) Or Organization(s):	Location(s) Of Covered Operations

Information required to complete this Schedule, if not shown above, will be shown in the Declarations.

A. Section II – Who Is An Insured is amended to include as an additional insured the person(s) or organization(s) shown in the Schedule, but only with respect to liability for "bodily injury", "property damage" or "personal and advertising injury" caused, in whole or in part, by:

1. Your acts or omissions; or
2. The acts or omissions of those acting on your behalf;

in the performance of your ongoing operations for the additional insured(s) at the location(s) designated above.

B. With respect to the insurance afforded to these additional insureds, the following additional exclusions apply:

This insurance does not apply to "bodily injury" or "property damage" occurring after:

1. All work, including materials, parts or equipment furnished in connection with such work, on the project (other than service, maintenance or repairs) to be performed by or on behalf of the additional insured(s) at the location of the covered operations has been completed; or
2. That portion of "your work" out of which the injury or damage arises has been put to its intended use by any person or organization other than another contractor or subcontractor engaged in performing operations for a principal as a part of the same project.

NOT FOR BID

**EXHIBIT B**

POLICY NUMBER:

**COMMERCIAL GENERAL LIABILITY  
CG 20 26 07 04**

**THIS ENDORSEMENT CHANGES THE POLICY. PLEASE READ IT CAREFULLY.**

**ADDITIONAL INSURED – DESIGNATED  
PERSON OR ORGANIZATION**

This endorsement modifies insurance provided under the following:

COMMERCIAL GENERAL LIABILITY COVERAGE PART

**SCHEDULE**

Name Of Additional Insured Person(s) Or Organization(s)
<p style="text-align: center; font-size: 2em; opacity: 0.5;">SAMPLE</p>
Information required to complete this Schedule, if not shown above, will be shown in the Declarations.

**Section II – Who Is An Insured** is amended to include as an additional insured the person(s) or organization(s) shown in the Schedule, but only with respect to liability for "bodily injury", "property damage" or "personal and advertising injury" caused, in whole or in part, by your acts or omissions or the acts or omissions of those acting on your behalf:

- A. In the performance of your ongoing operations; or
- B. In connection with your premises owned by or rented to you.

NOT FOR BID

**EXHIBIT**

**C**

POLICY NUMBER:

**COMMERCIAL GENERAL LIABILITY**  
CG 20 37 07 04

**THIS ENDORSEMENT CHANGES THE POLICY. PLEASE READ IT CAREFULLY.**

**ADDITIONAL INSURED – OWNERS, LESSEES OR  
CONTRACTORS – COMPLETED OPERATIONS**

This endorsement modifies insurance provided under the following:

COMMERCIAL GENERAL LIABILITY COVERAGE PART

**SCHEDULE**

Name Of Additional Insured Person(s) Or Organization(s):	Location And Description Of Completed Operations
<b>EXAMPLE</b>	
Information required to complete this Schedule, if not shown above, will be shown in the Declarations.	

**Section II – Who Is An Insured** is amended to include as an additional insured the person(s) or organization(s) shown in the Schedule, but only with respect to liability for "bodily injury" or "property damage" caused, in whole or in part, by "your work" at the location designated and described in the schedule of this endorsement performed for that additional insured and included in the "products-completed operations hazard".

NOT FOR BID



NOT FOR BID

**APPENDIX**

**B**

NOT FOR BID

NOT FOR BID

**Ordinance No. 3733**

**AN ORDINANCE OF THE VILLAGE OF VILLA PARK, DUPAGE COUNTY, ILLINOIS AMENDING THE REQUIREMENTS OF BIDDERS FOR CONSTRUCTION PROJECTS**

**WHEREAS**, the Village of Villa Park (the “*Village*”) is a duly organized and validly existing non home-rule municipality created in accordance with the Constitution of the State of Illinois of 1970 and the laws of the State; and,

**WHEREAS**, section 8-9-1 of the Illinois Municipal Code (65 ILCS 5/8-9-2) allows the Village to require competitive bidding after advertising for bids in the manner prescribed by ordinance; and,

**WHEREAS**, the President and Board of Trustees desire to adopt purchasing procedures to provide for additional requirements of bidders for construction projects to have active apprenticeship and training programs approved and registered with the United States Department of Labor’s Bureau of Apprenticeship and Training and to have bidders show three similar projects they constructed within the last five years.

**NOW, THEREFORE, BE IT ORDAINED** by the President and Board of Trustees of the Village of Villa Park, DuPage County, Illinois, as follows:

**Section 1.** That Section 2-219 of the Villa Park Municipal Code, as amended, be and is hereby amended by placing the existing text as subsection A. and adding a new subsection B. to read as follows:

“B. A responsible bidder for the construction of public works projects shall meet and submit evidence of compliance with the following requirements:

- (1) All applicable laws prerequisite to doing business in the State of Illinois,
- (2) A federal employer tax identification number or social security number,
- (3) Provision of Section 2000(e) of Chapter 21, Title 42 of the United States Code and Federal Executive Order No. 11246 as amended by Executive Order No. 11375 (known as the Equal Opportunity Employer provisions),
- (4) Certificates of insurance indicating the following coverage’s: general liability, worker’s compensation, completed operations, automobile, hazardous occupation and product liability
- (5) Compliance with all provisions of the Illinois Prevailing Wage Act, including wages, medical and hospitalization insurance and retirement for those trades covered in the Act,
- (6) The bidder and all bidder’s sub-contractors must participate in active apprenticeship and training programs approved and registered with the United States Department of Labor’s Bureau of Apprenticeship and Training for each of the trades of work contemplated under the proposed contract,
- (7) All contractors and sub-contractors are required to file certified payrolls as specified in Illinois Pubic Act 94-0515, and follow all provisions of the Employee Classification Act (820 ILCS 185/1 et seq.), and

(8) All bidders must provide three (3) projects of a similar nature constructed in the immediate past five (5) years with the name, address and telephone number of the contact person having knowledge of the project along with three (3) references (name, address, and telephone number) with knowledge of the integrity and business practices of the bidder.”

**Section 2.** This Ordinance shall be in full force and effect upon its passage, approval, and publication as provided by law.

Passed this 11 day of February, 2013.

AYES: ALL

NAYS: Aiello Bulthuis

ABSENT: \_\_\_\_\_

Approved this 11 day of February, 2013.

  
Village President

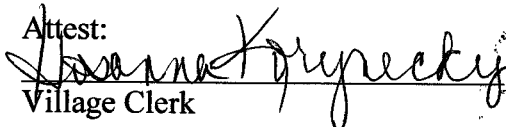
Attest:  
  
Village Clerk



Published in pamphlet form:

2-11, 2013

**APPENDIX**

**C**

NOT FOR BID

NOT FOR BID

# **Subsurface Investigation Report**

**For the**

## **Village of Villa Park Road Improvements**

**Villa Park, Illinois**

**Prepared for**

Mr. Kevin L. Mantels, EIT  
**Village of Villa Park**  
Public Works Department  
Villa Park, Illinois

**Prepared by**

***Applied GeoScience, Inc.***

2385 Hammond Dr., Suite 6  
Schaumburg, Illinois 60173  
847-303-0300

**February 12, 2015**

---

NOT FOR BID



# Applied GeoScience, Inc.

Geotechnical, Environmental & Materials Engineering

February 12, 2015

Mr. Kevin L. Mantels, EIT  
**Village of Villa Park**  
Public Works Department  
Villa Park, Illinois 60181

**Reference: Geotechnical Engineering Services**  
Village of Villa Park Road Improvements  
Adel Court, Cornell Avenue, Division Street, Ellsworth Avenue, Grant Avenue,  
Home Avenue Alley, Sidney Court, and Yale Avenue  
AGI Job No. 14-345

Dear Mr. Mantels:

The subsurface exploration at the above-referenced site has been completed. The attached report represents the findings of the subsurface exploration.

We appreciate the opportunity to be of service to you on this project. If you have any questions concerning the contents of this report, or if we may be of further service to you in any way, please do not hesitate to contact us.

**APPLIED GEOSCIENCE, INC.**

Adam M. Moghamis, P.E.  
Principal Engineer

enc.

## **INTRODUCTION**

Applied GeoScience, Inc. (AGI) has completed the subsurface exploration for the proposed road improvements for the Village of Villa Park. The subject streets and alleys included in this report are Adel Court, Cornell Avenue, Division Street, Ellsworth Avenue, Grant Avenue, Home Avenue Alley, Sidney Court, and Yale Avenue.

It is our understanding that the proposed improvements will include milling and resurfacing of the existing street and alley pavement. The purpose of this investigation is to provide information regarding the pavement thickness, subbase type, subbase thickness, and subgrade type at each core hole and borehole location.

## **SUBSURFACE EXPLORATION PROCEDURES**

### **Soil Borings**

Thirty-four (34) soil borings were performed during the investigation between January 21 and January 30, 2015. The borings were performed using a truck-mounted drill rig with continuous flight augers and were extended to a depths of 10.25 inches to 7.0 feet. Representative samples were obtained employing split spoon sampling procedures in accordance with ASTM Specification D-1586. Samples obtained in the field were returned to our laboratory for further examination and testing. Split spoon sampling involves driving a 2.0-inch outside diameter split-barrel sampler into the soil with a 140-pound weight falling freely through a distance of 30 inches. The number of blows required to advance the sampler the last 12 inches is termed the Standard Penetration Resistance (N) and is included on the boring logs. The N value is an indication of the relative density of the soil and, to a lesser degree of accuracy, the consistency of cohesive soil. All split spoon soil samples obtained from the drilling operation were visually classified in the field. Cohesive soils were tested for unconfined compressive strength using a calibrated penetrometer test device. Due to the low temperatures during the boring process, the soil in the first split spoon sample was often frozen. The frozen soil results in Standard Penetration Resistance (N) and unconfined compressive strength values that are higher than what would be observed in unfrozen conditions. Results for relative density and a qualitative description of compressive strengths are included in the soil boring logs, which can be found in Attachment B.

Samples were sealed and returned to AGI's laboratory for further examination, classification and testing. Field logs of each boring were prepared by our field engineer. These logs include visual classifications of the materials encountered during drilling as well as the engineer's interpretation of the subsurface conditions between samples. Final boring logs included with this report represent an interpretation of the field logs and include modifications based on the laboratory testing of the samples.

### **Pavement Cores**

Thirty-four (34) pavement cores were performed between January 21 and January 30, 2015, using a diamond bit core barrel. Water was used as a coolant. Upon completion of the cores, the core holes were patched to match the existing grade. Pavement cores were measured and visually inspected in the field. A summary and photographs of the cores is included in the coring diagrams, which can be found in Appendix C.

### **SOIL CONDITIONS**

The subsurface exploration and testing program for the soil borings revealed that subgrade soils in the areas of the proposed improvements generally consisted of asphalt or concrete over a crushed stone or recycled stone subbase and underlain by silty clay fill materials or natural silty clay. Organic clay was encountered in Borings B-7, B-8, B-10, B-13, B-15, B-25, B-27, and B-28.

Detailed descriptions of the subgrade soil conditions beneath the pavement materials are provided below and shown in the borings logs in Appendix B. The stratification lines shown on the boring logs represent the approximate boundary between soil types. The actual transition may be more gradual.

#### Adele Court: Soil Borings B-1 through B-2

The existing pavement consisted of 8.00 to 8.25 inches of concrete at the ground surface over approximately 21.75 to 22.00 inches of crushed limestone. In Boring B-1, the crushed limestone was underlain by silty clay fill materials extending to a depth of 5.5 feet below ground surface. The fill materials were followed by silty clay in a stiff condition extending to the boring termination depth of 7.0 feet. In Boring B-2, the crushed limestone was underlain by silty clay in a very stiff condition extending to the boring termination depth of 7.0 feet.

#### Cornell Avenue: Soil Borings B-3 through B-10

The existing pavement consisted of 5.50 to 7.25 inches of asphalt at the ground surface over 4.00 to 17.00 inches of crushed limestone. In general, the crushed limestone was underlain by silty clay in a stiff condition extending to the boring termination depth of 7.0 feet below ground surface. In Borings B-4, B-5, and B-6 the crushed limestone was underlain by silty clay fill materials extending to depths of 2.0 to 2.5 feet. The fill materials were followed by silty clay in a very stiff condition extending to the boring termination depth of 7.0 feet. In Borings B-7 and B-8, the crushed limestone was underlain by a layer of organic clay approximately 6.00 to 7.50 inches thick. The organic clay was underlain by silty clay fill materials extending to depths of 3.5 to 4.0 feet. The fill materials were followed by silty clay in a very stiff and stiff condition extending to the boring termination depth of 7.0 feet. In Boring B-10, the crushed stone was underlain by silty clay fill materials extending to a depth of 1.8 feet. The fill materials were followed by a layer of organic clay approximately 8.50 inches thick. The organic clay was underlain by silty clay in a very stiff condition extending to the boring termination depth of 7.0 feet.

Division Street: Soil Borings B-11 through B-15

The existing pavement consisted of 6.00 to 7.25 inches of asphalt at the ground surface over 5.00 to 10.00 inches of crushed limestone. In Borings B-11 and B-12, the crushed limestone was underlain by silty clay in a very stiff condition extending to the boring termination depth of 7.0 feet below ground surface. In Borings B-13 and B-15, the crushed limestone was underlain by a layer of organic clay approximately 8.50 to 19.25 inches thick. The organic clay was followed by silty clay in a stiff condition extending to the boring termination depth of 7.0 feet. In Boring B-14, the crushed limestone was underlain by silty clay fill materials extending to the boring termination depth of 3.5 feet. Boring B-14 was terminated at 3.5 feet below ground surface due to a possible utility conflict.

Ellsworth Avenue: Soil Borings B-16 through B-24

The existing pavement consisted of 7.75 to 10.25 inches of concrete at the ground surface over approximately 4.00 to 22.25 inches of crushed limestone. In general, the crushed limestone was underlain by silty clay fill materials extending to depths of 2.5 to 5.0 feet below ground surface. The fill materials were followed by silty clay in a stiff condition extending to the boring termination depth of 7.0 feet. In Boring B-18, the crushed limestone was underlain by silty clay in a stiff to soft condition extending to the boring termination depth of 7.0 feet. Boring B-24 was terminated at a depth of 10.25 inches due to auger refusal on steel rebar.

Grant Avenue: Soil Borings B-25 through B-26

The existing pavement consisted of 2.25 to 3.00 inches of asphalt at the ground surface over 9.75 to 19.00 inches of crushed limestone. In Boring B-25, the crushed limestone was underlain by a layer of organic clay approximately 1.5 feet thick. The organic clay was followed by silty clay in a stiff condition extending to the boring termination depth of 7.0 feet below ground surface. In Boring B-26, the crushed limestone was underlain by silty clay in a very stiff condition extending to the boring termination depth of 7.0 feet.

Home Avenue Alley: Soil Borings B-27 through B-31

In general, the existing pavement consisted of 3.00 to 5.50 inches of asphalt at the ground surface over 7.75 to 15.50 inches of recycled stone. In Borings B-27 and B-28, the recycled stone was underlain by a layer of organic clay approximately 1.4 to 1.5 feet thick. The organic clay was followed by silty clay in a very stiff and stiff condition extending to the boring termination depth of 7.0 feet below ground surface. In Boring B-29, the recycled stone was underlain by silty clay in a stiff condition extending to the boring termination depth of 7.0 feet. In Boring B-30, the recycled stone was underlain by silty clay fill materials extending to a depth of 2.5 feet. The fill materials were followed by silty clay in a very stiff condition extending to the boring termination depth of 7.0 feet. In Boring B-31, the existing pavement consisted of asphalt over 15.50 inches of crushed limestone. The crushed limestone was underlain by silty clay fill materials extending to a depth of 3.0 feet. The fill materials were underlain by silty clay in a very stiff condition extending to the boring termination depth of 7.0 feet.

Sidney Court: Soil Borings B-32 through B-33

The existing pavement consisted of 8.00 to 8.50 inches of concrete at the ground surface over approximately 15.50 to 28.00 inches of crushed limestone. The crushed limestone was underlain by silty clay in a very stiff and stiff condition extending to the boring termination depth of 7.0 feet.

Yale Avenue: Soil Boring B-34

The existing pavement consisted of 3.50 inches of asphalt at the ground surface over 11.50 inches of crushed limestone. Boring B-34 was terminated at 1.3 feet due to a possible utility conflict.

**LABORATORY TESTING PROGRAM**

The testing program consisted of performing water content tests on selected soil samples according to ASTM D-2216 and organic content determination in accordance with ASTM D-2974. The cohesive soils were tested for unconfined compressive strength using both a calibrated penetrometer and/or RIMAC testing device. These tests were performed upon representative portions of the samples obtained in the field. The results of all testing performed, along with a visual classification of the material based upon both a textural analysis and the Unified Soil Classification System, are indicated on the boring logs, Appendix B.

**GROUNDWATER CONDITIONS**

Water level observations were recorded while drilling and immediately after completion of the borings. No groundwater was encountered in any of the borings. The borings were backfilled after drilling for safety reasons.

Groundwater observations in the borings provide an approximate indication of the groundwater conditions at the time the borings were drilled. Since the soils encountered were predominately cohesive, which have a low coefficient of permeability, much time is required for the groundwater to seep into the boreholes and attain an equilibrium level. Longer-term observations in cased holes or piezometers would be necessary for a more accurate evaluation of the groundwater conditions at this site.

Fluctuations in the groundwater level and the possible development of perched water table should be anticipated throughout the year depending on variations in climatological conditions and other factors not apparent at the time the borings were performed. The possibility of groundwater level fluctuation should be considered when developing the design and construction plans for the project.

## **ANALYSIS AND GUIDELINE RECOMMENDATIONS**

The attached boring logs describe subsurface conditions only at the specified locations on the site. With these limitations, the following general geotechnical guideline recommendations are provided for the proposed road improvements.

Based on field and laboratory analysis, it was determined that the silty clay fill materials and natural silty clay soil encountered in the borings is relatively impermeable. Borings also indicated the presence of shallow, very moist base materials below the pavement, presumably due to the low infiltration rate of the clay soils. It is our engineering opinion that any pavement failure is due to the cyclical freezing and thawing of the trapped water. A lack of periodic maintenance may have resulted in pavement deterioration and additional infiltration of surface water. Our remedial recommendations are described below.

### **Option One: Short Term Remedial Treatment**

Consideration may be given to patching, sealing, milling/grinding, and overlay procedures for temporary remediation of the existing pavement. If this option is chosen, 1.00 to 1.50 inches of existing pavement should be milled/grinded and resurfaced. Full depth patching may be required after milling/grinding, and an underdrainage system should be installed. Underdrains furnish an outlet for any surface water and/or groundwater that would otherwise build up in the silty clay soils. The drains should be installed at appropriate intervals between low points as determined by the site's topography. All underdrains and slope drains should be tied into storm sewers or ditches. IDOT gradation FA-1 or CA-7 backfill, or equivalent, should be used.

**Short term remedial treatment such as patching, sealing, and in some areas, deep patching is recommended for the following street sections:**

1. Adele Court from Ellsworth Avenue to the East End
2. Cornell Avenue from Metra Parking to Division Street
3. Cornell Avenue from Oak Street to Elm Street
4. Division Street from Harvard Avenue to Yale Avenue
5. Division Street from Yale Avenue to Princeton Avenue
6. Division Street from Princeton Avenue to Ardmore Avenue
7. Ellsworth Avenue from Armitage Avenue to 660 feet
8. Ellsworth Avenue from 660 feet to Sidney Court
9. Ellsworth Avenue from Sidney Court to Adele Court
10. Ellsworth Avenue from 660 feet to North Avenue
11. Sidney Court from Ellsworth Avenue to East End
12. Yale Avenue from North End to Division Street

**Short term remedial treatment such as milling/grinding and resurfacing, with possible deep patching, is recommended for the following street sections:**

1. Cornell Avenue from Division Street to Oak Street
2. Cornell Avenue from Elm Street to St. Charles Road
3. Ellsworth Avenue from Adele Court to 660 feet

**Option Two: Long Term Remedial Treatment (Failed Pavement)**

If economically feasible, the ideal remedial treatment for failed pavement involves removal and replacement of the existing pavement at all locations and the installation of an underdrainage system. The observed very stiff silty clay subgrade encountered below the pavement appears to be in a stable condition.

Following the removal of the existing pavement, the exposed subgrade should be proofrolled. Proofrolling aids in providing a firm subgrade and for delineating soft or disturbed areas that may exist at or slightly below subgrade level. Proofrolling will also identify any areas of soft or loose fill materials at areas where fill extend to depths of up to 2.5 to 3.5 feet at the site. If no deflection is observed at areas of fill materials, no remedial treatment is required. If deflection is observed, AGI recommends that a minimum of 1 foot of the fill materials be removed and replaced with properly compacted engineered fill materials. Loose or disturbed soils may only require scarification and recompaction in-place. Proofrolling may be accomplished with a fully loaded, tandem-axle dump truck or other equipment providing an equivalent subgrade loading. A minimum gross weight of 25 tons is recommended for the proofrolling equipment. Proofrolling should be done in dry weather conditions only as a wet subgrade will not allow detection of buried weak soils.

Any new fill or existing stockpiled gravel fill placed in the upper 12 inches below the pavement section should consist of approved granular material that is free of organic matter and debris. The fill should be placed and compacted in lifts not exceeding 9 inches in loose thickness. Each fill lift should be compacted to a minimum of 95% of the maximum dry density of the material as determined by ASTM Specification D-1557.

To prevent future pavement failure, an underdrainage system is recommended at the site. Underdrains furnish an outlet for any surface and/or groundwater that would otherwise build up in the granular material and should be installed at the lowest point of the granular subgrade replacement. The underdrains should be placed at the low points of the profile grade and at approximately 30 feet intervals between low points. All underdrains and slope drains should be tied into storm sewers or ditches. FA-1 or CA-7 backfill, or equivalent, should be used.

**Long term remedial treatment is recommended for the following street sections:**

1. Grant Avenue from Washington Boulevard to the South End
2. Home Avenue Alley from Harvard Avenue to the pavement change
3. Home Avenue Alley from the pavement change to Ardmore Avenue

**CONSTRUCTION CONSIDERATIONS**

Depending upon weather conditions during and prior to construction, some groundwater could be encountered in the anticipated construction excavations on the site. It is anticipated that any seepage into the construction excavation could be controlled with drainage ditches or by pumping from sump pits.

All excavation should be performed in accordance with the latest Occupational Safety and Health Administration requirements.

New requirements of the Illinois Environmental Protection Agency mandate that all uncontaminated soil that is to be removed from the site, including soil mixed with other clean construction or demolition debris (CCDD), sent to either a CCDD or an uncontaminated soil fill operation must be certified to be uncontaminated soil in accordance with Section 22.52(f)(2)(B) or Section 22.51a(d)(2)(B), respectively, of the Environmental Protection Act [415 ILCS 5]. Certifications for commercial/industrial properties must be made by a licensed professional engineer. Certifications for uncontaminated soil removed from a site that has not been used for commercial or industrial purposes may be made by either the site owner/operator or by a licensed professional engineer on the IEPA's forms. These forms, along with the analytical results, must be submitted to the fill operation prior to disposal of any soils excavated from the site. AGI's environmental professionals are qualified to perform testing and certifications in accordance with the IEPA's regulations.

Continuous observation by a geotechnical engineer or his representative should be maintained during site preparation and compaction of all fill and backfill material.

The soils at this site will be susceptible to disturbance from construction activities, particularly if water is present near the subgrade level. Care should be taken during excavation and construction of footings to minimize disturbance of the bearing soils. The base of all foundation excavations should be free of water and loose soil prior to placing concrete. Concrete should be placed as soon as possible after excavation to minimize bearing soil disturbance. Should the soils at bearing level become saturated, desiccated, or disturbed, the affected soils should be removed prior to placing concrete.

**GENERAL COMMENTS**

The analysis and guideline recommendations presented in this report are based upon the data obtained from the soil borings performed at the indicated locations and from any other information discussed in this report. This report does not reflect any variations which may occur

between borings or across the site. The nature and extent of such variations may not become evident until construction. If variations become evident, it will be necessary to reevaluate the recommendations of this report.

Boring locations were spaced as closely as economically feasible for this project. Unanticipated subsurface conditions are sometimes encountered between borings.

It is further recommended that Applied GeoScience, Inc. be retained for testing and observation during earthwork construction phases to help ensure that design requirements are met.

This report has been prepared for the exclusive use of our client for specific application to the project discussed and has been prepared in accordance with generally accepted geotechnical engineering practices. No other warranties, either expressed or implied, are intended or made. In the event that any changes in the nature, design, or location of the project as outlined in this report are planned, the conclusions and recommendations contained in this report shall not be considered valid unless the changes are reviewed and the conclusions of this report modified or verified in writing by the geotechnical engineer.

NOT FOR BIDD

NOT FOR BID

**APPENDIX A**

**Soil Boring Location Diagram**

NOT FOR BID

NOT FOR BID

2015 Village of Villa Park Road Improvements - Boring Diagrams

Adele Court (B-1 to B-2)

**BORING B-1: 226 East Adele Court**

**BORING B-2: 235 East Adele Court**

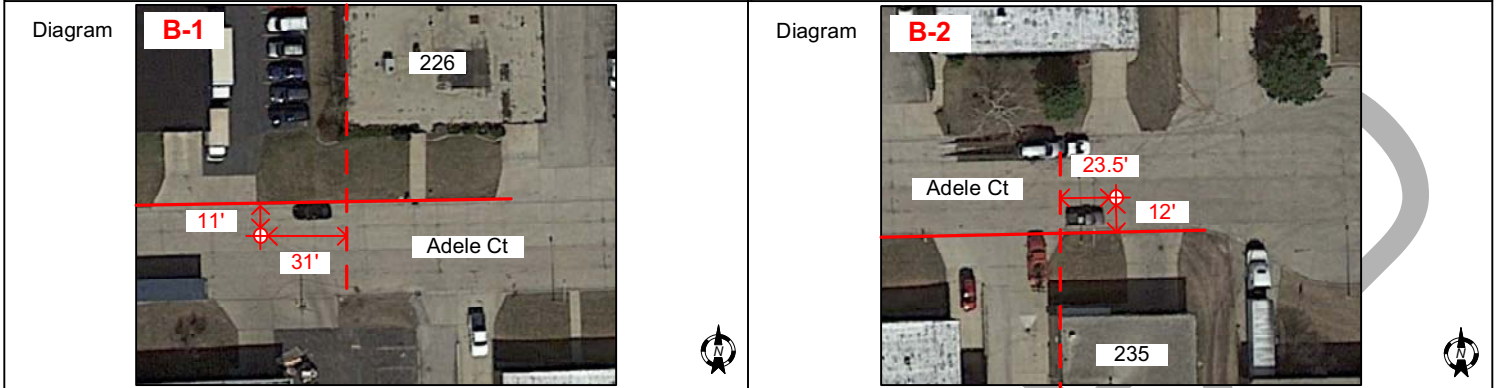

NOT FOR

# 2015 Village of Villa Park Road Improvements - Boring Diagrams

## North Cornell Avenue (B-3 to B-10)

### BORING B-3: 328 North Cornell Avenue

### BORING B-4: 239 North Cornell Avenue

Diagram

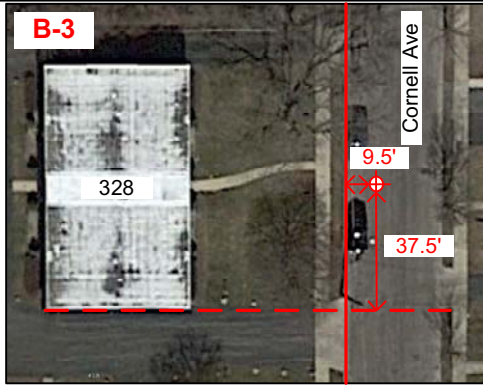

Diagram

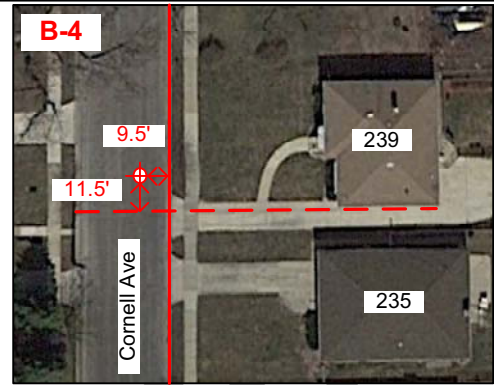

### BORING B-5: 222 North Cornell Avenue

### BORING B-6: 206 North Cornell Avenue

Diagram

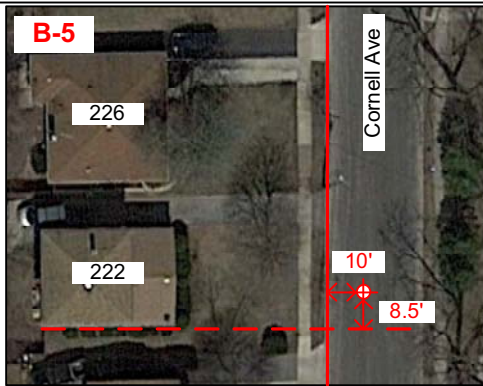

Diagram

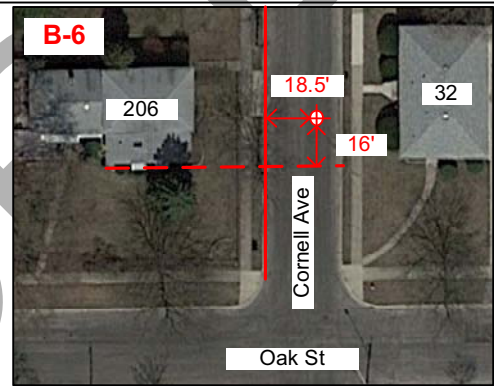

### BORING B-7: 134 North Cornell Avenue

### BORING B-8: 110 North Cornell Avenue

Diagram

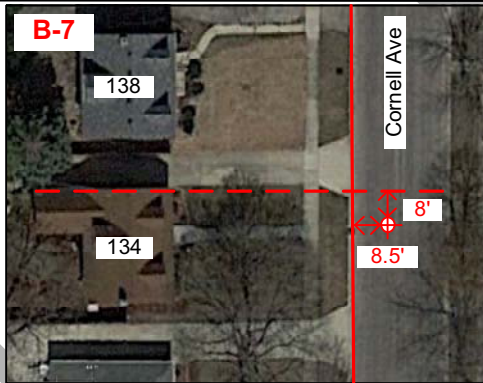

Diagram

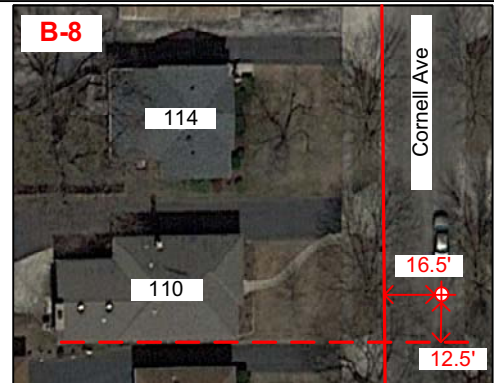

### BORING B-9: 44 North Cornell Avenue

### BORING B-10: 18 North Cornell Avenue

Diagram



Diagram

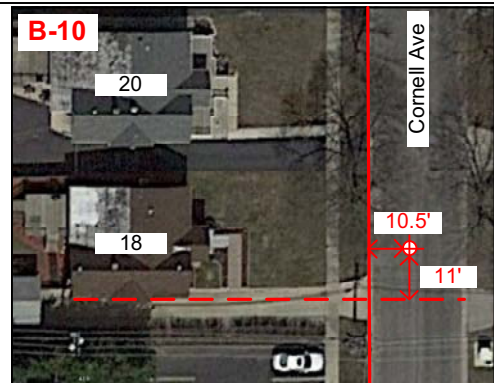

## 2015 Village of Villa Park Road Improvements - Boring Diagrams

### West Division Street (B-11 to B-15)

#### BORING B-11: 148 West Division Street

#### BORING B-12: 126 West Division Street

Diagram

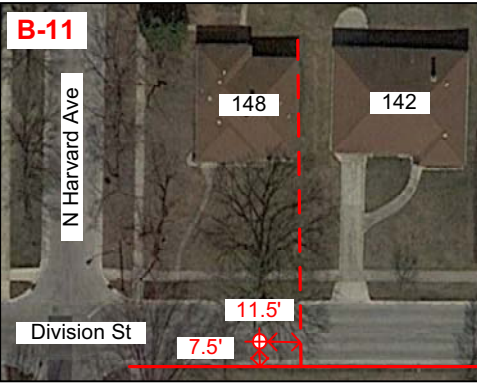

Diagram

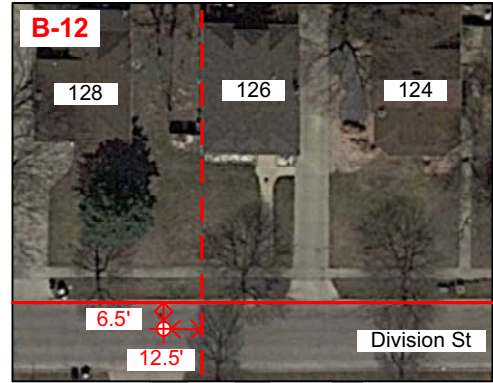

#### BORING B-13: 111 West Division Street

#### BORING B-14: 35 West Division Street

Diagram

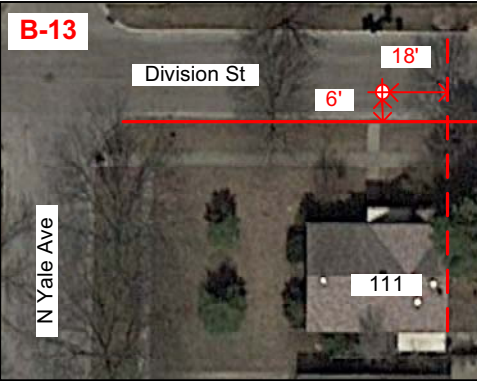

Diagram



#### BORING B-15: 20 West Division Street

Diagram



# 2015 Village of Villa Park Road Improvements - Boring Diagrams

## Ellsworth Avenue (B-16 to B-24)

### BORING B-16: 824 Ellsworth Avenue

Diagram

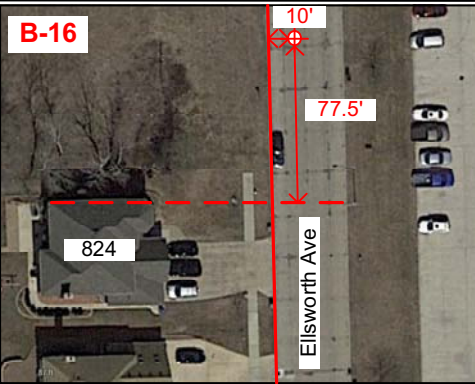

### BORING B-17: 854 Ellsworth Avenue

Diagram

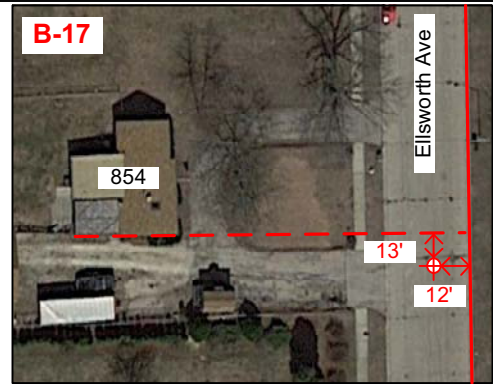

### BORING B-18: 904 Ellsworth Avenue

Diagram



### BORING B-19: 932 Ellsworth Avenue

Diagram

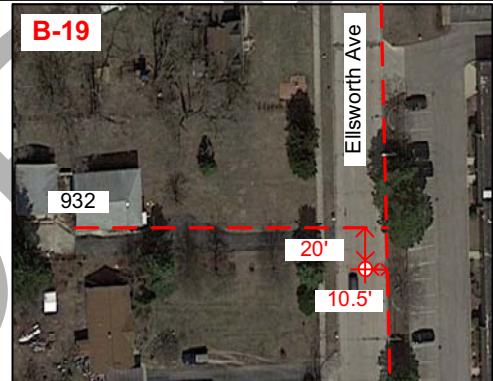

### BORING B-20: 995 Ellsworth Avenue

Diagram

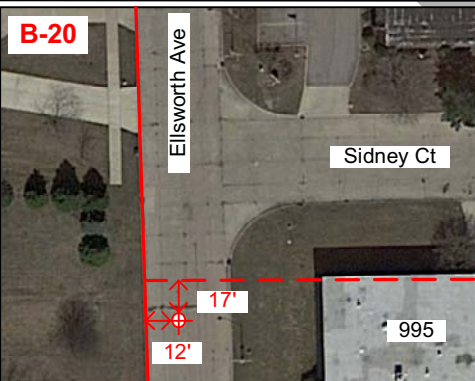

### BORING B-21: 1022 Ellsworth Avenue

Diagram

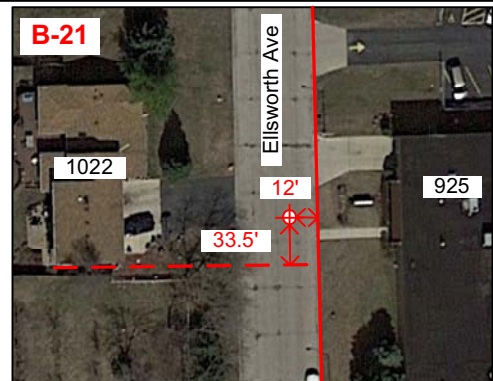

### BORING B-22: 875 Ellsworth Avenue

Diagram



### BORING B-23: 865 Ellsworth Avenue

Diagram

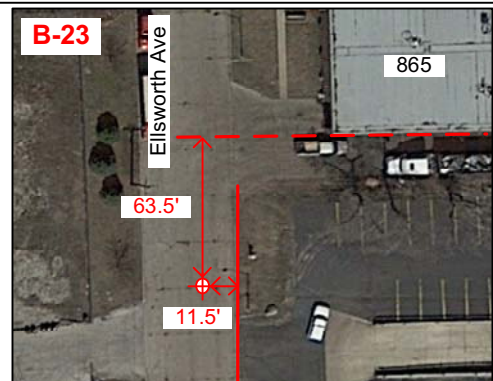

2015 Village of Villa Park Road Improvements - Boring Diagrams

Ellsworth Avenue (B16 to B-24)

BORING B-24: 150 North Avenue

Diagram



NOT FOR BID

2015 Village of Villa Park Road Improvements - Boring Diagrams

Grant Avenue (B-25 to B-26)

BORING B-25: 609 Grant Avenue

BORING B-26: 630 Grant Avenue

Diagram

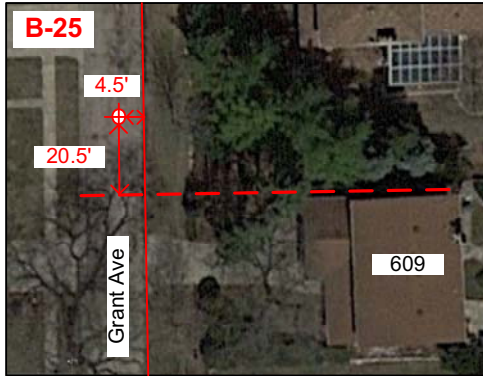

Diagram



NOT FOR

## 2015 Village of Villa Park Road Improvements - Boring Diagrams

### Home Avenue Alley (B-27 to B-31)

#### BORING B-27: 149 West St Charles Road

Diagram



#### BORING B-28: 125 West St Charles Road

Diagram

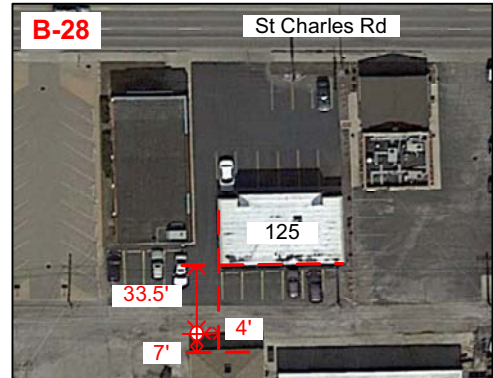

#### BORING B-29: 55-A West St Charles Road

Diagram

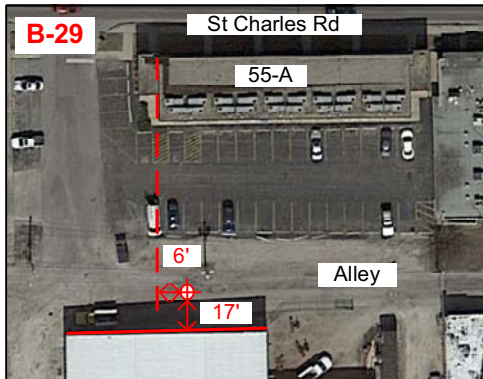

#### BORING B-30: 28 Home Avenue

Diagram



#### BORING B-31: 20 South Ardmore Avenue

Diagram

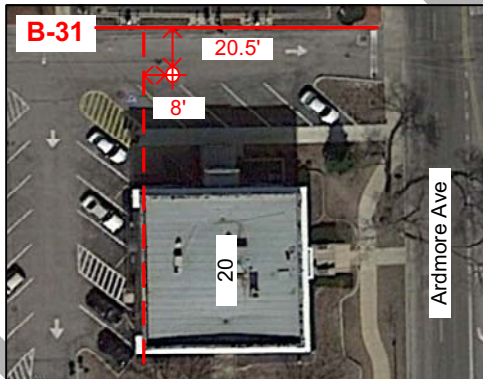

2015 Village of Villa Park Road Improvements - Boring Diagrams

East Sidney Court (B-32 to B-33)

BORING B-32: 995 Ellsworth Avenue

BORING B-33: 236 East Sidney Court

Diagram

**B-32**

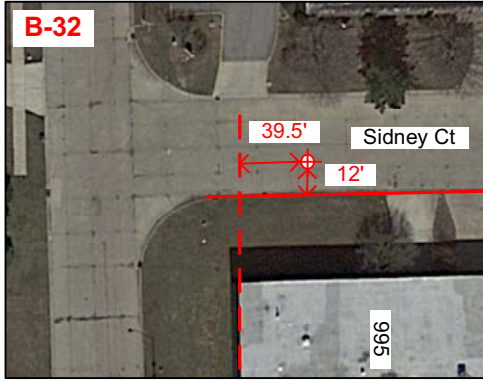

Diagram

**B-33**

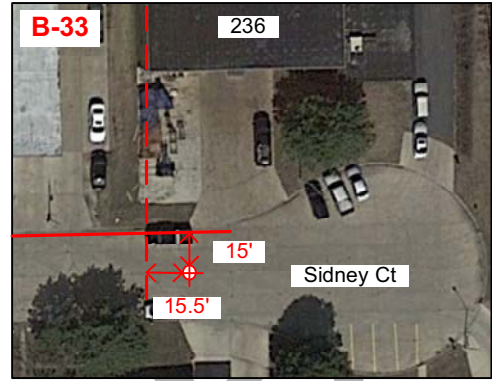

NOT FOR

2015 Village of Villa Park Road Improvements - Boring Diagrams

North Yale Avenue (B-34)

**BORING B-34: 112 West Division Street**

Diagram

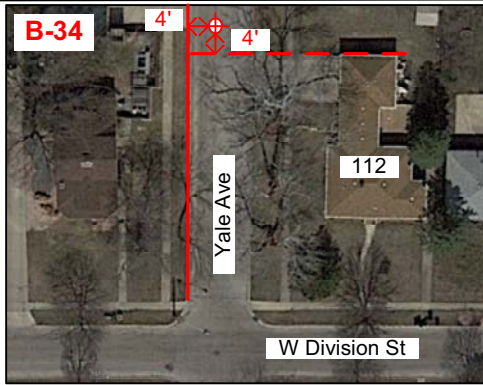

NOT FOR BID

NOT FOR BID

**APPENDIX B**

**Soil Boring Logs**

NOT FOR BID

NOT FOR BID

CLIENT: Village of Villa Park	PROJECT: 2015 Village of Villa Park Road Improvements
-------------------------------	---

ADDRESS: 226 E Adele Ct (from Ellsworth Ave to East End)	LOCATION: Various Streets
--	---------------------------

COUNTY: DuPage	GRAPHIC LOG	SAMPLES				TESTS				
		DEPTH (FT.)	SPT-N BLOWS / FT.	NUMBER	TYPE	% RECOVERY	MOISTURE, %	HNu Units ppm	Qu tsf Failure Type	DRY DENSITY PCF
SURFACE ELEVATION Datum:										
8.25 inches of concrete 0.7	▽▽▽									
~21.75 inches of crushed limestone 2.5	●●●	36	1	SS	94					
FILL, silty clay, trace sand, gravel & organics, brown, gray & black, stiff 5.5	▨▨▨	8	2	SS	94	25		1.8		
SILTY CLAY, trace sand & gravel, brown & gray, stiff, (CL) 7.0	▨▨▨	4	3	SS	100	27		1.1		
End Of Boring										

WATER LEVEL OBSERVATIONS	
WL	▽ Dry
WL	▼
WL	▼

**Applied GeoScience, Inc.**  
 2385 Hammond Drive, Suite 6  
 Schaumburg, Illinois 60173  
 Tel: (847) 303-0300  
 Fax: (847) 303-0900

STARTED	1-29-15	FINISHED	1-29-15
DRILL CO.	GBE	DRILL RIG	CME-75
DRILLER	Gabe	ASS'T DRILLER	
ENG/GEOL.	JG	APPROVED	AM

CLIENT: Village of Villa Park	PROJECT: 2015 Village of Villa Park Road Improvements
-------------------------------	---

ADDRESS: 235 E Adele Ct (from Ellsworth Ave to East End)	LOCATION: Various Streets
--	---------------------------

COUNTY: DuPage	GRAPHIC LOG	SAMPLES				TESTS						
		DEPTH (FT.)	SPT-N BLOWS / FT.	NUMBER	TYPE	% RECOVERY	MOISTURE, %	HNu Units ppm	Qu tsf	Failure Type	DRY DENSITY PCF	Est. Coefficient of Permeability k <sub>v</sub> (cm/sec)
SURFACE ELEVATION Datum:												
8 inches of concrete 0.7	[Symbol]											
~22 inches of crushed limestone 2.5	[Symbol]	51	1	SS	61							
SILTY CLAY, trace sand & gravel, brown & gray, very stiff, (CL) 7.0	[Symbol]	11	2	SS	11	20		2				
End Of Boring		14	3	SS	11	17		2.5				

WATER LEVEL OBSERVATIONS	
WL	▽ Dry
WL	▼
WL	▼

**Applied GeoScience, Inc.**  
 2385 Hammond Drive, Suite 6  
 Schaumburg, Illinois 60173  
 Tel: (847) 303-0300  
 Fax: (847) 303-0900

STARTED	1-29-15	FINISHED	1-29-15
DRILL CO.	GBE	DRILL RIG	CME-75
DRILLER	Gabe	ASS'T DRILLER	
ENG/GEOL.	JG	APPROVED	AM

CLIENT: Village of Villa Park	PROJECT: 2015 Village of Villa Park Road Improvements
-------------------------------	---

ADDRESS: 328 N Cornell Ave (from Metra Parking to Division)	LOCATION: Various Streets
---	---------------------------

COUNTY: DuPage	CITY & STATE: Villa Park, Illinois	SURFACE ELEVATION	Datum:	GRAPHIC LOG	SAMPLES				TESTS						
					DEPTH (FT.)	SPT-N BLOWS / FT.	NUMBER	TYPE	% RECOVERY	MOISTURE, %	HNu Units ppm	Qu tsf	Failure Type	DRY DENSITY PCF	Est. Coefficient of Permeability k <sub>v</sub> (cm/sec)
5.5 inches of asphalt															
0.5															
7.5 inches of crushed limestone															
1.1															
SILTY CLAY, trace sand & gravel, brown, frozen soil, (CL)															
2.5															
SILTY CLAY, trace sand & gravel, brown, very stiff, (CL)															
7.0															
End Of Boring															

WATER LEVEL OBSERVATIONS	
WL	▽ Dry
WL	▼
WL	▼

**Applied GeoScience, Inc.**  
 2385 Hammond Drive, Suite 6  
 Schaumburg, Illinois 60173  
 Tel: (847) 303-0300  
 Fax: (847) 303-0900

STARTED	1-30-15	FINISHED	1-30-15
DRILL CO.	Williams	DRILL RIG	45-C
DRILLER	Pecka	ASS'T DRILLER	
ENG/GEOL.	JG	APPROVED	AM

CLIENT: Village of Villa Park	PROJECT: 2015 Village of Villa Park Road Improvements
-------------------------------	---

ADDRESS: 239 N Cornell Ave (from Metra Parking to Division)	LOCATION: Various Streets
---	---------------------------

COUNTY: DuPage	CITY & STATE: Villa Park, Illinois	SURFACE ELEVATION Datum:	GRAPHIC LOG	SAMPLES				TESTS						
				DEPTH (FT.)	SPT-N BLOWS / FT.	NUMBER	TYPE	% RECOVERY	MOISTURE, %	HNu Units ppm	Qu tsf	Failure Type	DRY DENSITY PCF	Est. Coefficient of Permeability k <sub>v</sub> (cm/sec)
6 inches of asphalt														
0.5 15 inches of crushed limestone														
1.8 FILL, silty clay, trace sand & gravel, brown & gray, frozen soil														
2.5 SILTY CLAY, trace sand & gravel, brown & gray, very stiff, (CL)														
7.0 End Of Boring														
				26	1	SS	89	23						
				9	2	SS	78	18		2.75				
				7	3	SS	100	19		2.5				

WATER LEVEL OBSERVATIONS	
WL	▽ Dry
WL	▼
WL	▼

**Applied GeoScience, Inc.**  
 2385 Hammond Drive, Suite 6  
 Schaumburg, Illinois 60173  
 Tel: (847) 303-0300  
 Fax: (847) 303-0900

STARTED	1-30-15	FINISHED	1-30-15
DRILL CO.	Williams	DRILL RIG	45-C
DRILLER	Pecka	ASS'T DRILLER	
ENG/GEOL.	JG	APPROVED	AM

CLIENT: Village of Villa Park	PROJECT: 2015 Village of Villa Park Road Improvements
-------------------------------	---

ADDRESS: 222 N Cornell Ave (from Division St to Oak St)	LOCATION: Various Streets
---	---------------------------

COUNTY: DuPage	CITY & STATE: Villa Park, Illinois	SURFACE ELEVATION	Datum:	GRAPHIC LOG	SAMPLES				TESTS						
					DEPTH (FT.)	SPT-N BLOWS / FT.	NUMBER	TYPE	% RECOVERY	MOISTURE, %	HNu Units ppm	Qu tsf	Failure Type	DRY DENSITY PCF	Est. Coefficient of Permeability k <sub>v</sub> (cm/sec)
5.75 inches of asphalt															
0.5															
11 inches of crushed limestone															
1.4															
FILL, silty clay, trace sand & gravel, brown & gray, frozen soil															
2.5															
SILTY CLAY, trace sand & gravel, brown, very stiff, (CL)															
7.0															
End Of Boring															

WATER LEVEL OBSERVATIONS	
WL	▽ Dry
WL	▼
WL	▼

**Applied GeoScience, Inc.**  
 2385 Hammond Drive, Suite 6  
 Schaumburg, Illinois 60173  
 Tel: (847) 303-0300  
 Fax: (847) 303-0900

STARTED	1-30-15	FINISHED	1-30-15
DRILL CO.	Williams	DRILL RIG	45-C
DRILLER	Pecka	ASS'T DRILLER	
ENG/GEOL.	JG	APPROVED	AM

CLIENT: Village of Villa Park	PROJECT: 2015 Village of Villa Park Road Improvements
-------------------------------	---

ADDRESS: 206 N Cornell Ave (from Division St to Oak St)	LOCATION: Various Streets
---	---------------------------

COUNTY: DuPage	CITY & STATE: Villa Park, Illinois	SURFACE ELEVATION	Datum:	GRAPHIC LOG	SAMPLES				TESTS						
					DEPTH (FT.)	SPT-N BLOWS / FT.	NUMBER	TYPE	% RECOVERY	MOISTURE, %	HNu Units ppm	Qu tsf	Failure Type	DRY DENSITY PCF	Est. Coefficient of Permeability k <sub>v</sub> (cm/sec)
6.5 inches of asphalt															
0.9 4 inches of crushed limestone															
FILL, silty clay, trace sand & gravel, black gray & brown, frozen soil															
2.0 SILTY CLAY, trace sand & gravel, brown & gray, very stiff, (CL)															
End Of Boring				5	10	1	SS	78	25						
				13	2	SS	50	19		2.75					
				10	3	SS	100	21		3					
				5	10	3	SS	100	21			2.5			

WATER LEVEL OBSERVATIONS		<b>Applied GeoScience, Inc.</b> 2385 Hammond Drive, Suite 6 Schaumburg, Illinois 60173 Tel: (847) 303-0300 Fax: (847) 303-0900	STARTED	1-30-15	FINISHED	1-30-15	
WL	▽		Dry	DRILL CO.	Williams	DRILL RIG	45-C
WL	▼			DRILLER	Pecka	ASS'T DRILLER	
WL	▼			ENG/GEOL.	JG	APPROVED	AM

CLIENT: Village of Villa Park	PROJECT: 2015 Village of Villa Park Road Improvements
-------------------------------	---

ADDRESS: 134 N Cornell Ave (from Oak St to Elm St)	LOCATION: Various Streets
--	---------------------------

COUNTY: DuPage	CITY & STATE: Villa Park, Illinois	SURFACE ELEVATION	Datum:	GRAPHIC LOG	SAMPLES				TESTS						
					DEPTH (FT.)	SPT-N BLOWS / FT.	NUMBER	TYPE	% RECOVERY	MOISTURE, %	HNu Units ppm	Qu tsf	Failure Type	DRY DENSITY PCF	Est. Coefficient of Permeability k <sub>v</sub> (cm/sec)
0.5 6 inches of asphalt															
1.4 10.5 inches of crushed limestone															
2.0 ORGANIC CLAY, black Organic Content = 2.4%					10	1	SS	61	27						
3.5 FILL, silty clay, trace sand & gravel, brown & gray, stiff									17			2.25			
7.0 SILTY CLAY, trace sand & gravel, brown, very stiff, (CL)					7	2	SS	67	14			3			
					5										
					8	3	SS	44	22			2.5			
7.0 End Of Boring															

WATER LEVEL OBSERVATIONS	
WL	▽ Dry
WL	▼
WL	▼

**Applied GeoScience, Inc.**  
 2385 Hammond Drive, Suite 6  
 Schaumburg, Illinois 60173  
 Tel: (847) 303-0300  
 Fax: (847) 303-0900

STARTED	1-30-15	FINISHED	1-30-15
DRILLER	Pecka	ASS'T DRILLER	
ENG/GEOL.	JG	APPROVED	AM

CLIENT: Village of Villa Park	PROJECT: 2015 Village of Villa Park Road Improvements
-------------------------------	---

ADDRESS: 110 N Cornell Ave (from Oak St to Elm St)	LOCATION: Various Streets
--	---------------------------

COUNTY: DuPage	CITY & STATE: Villa Park, Illinois	SURFACE ELEVATION	Datum:	GRAPHIC LOG	SAMPLES				TESTS						
					DEPTH (FT.)	SPT-N BLOWS / FT.	NUMBER	TYPE	% RECOVERY	MOISTURE, %	HNu Units ppm	Qu tsf	Failure Type	DRY DENSITY PCF	Est. Coefficient of Permeability k <sub>v</sub> (cm/sec)
7.25 inches of asphalt															
0.6															
17 inches of crushed limestone															
2.0					34	1	SS	33							
2.5									24		1.75				
ORGANIC CLAY, black Organic Content = 5.9%															
4.0															
FILL, silty clay, trace sand & gravel, black, gray & brown, stiff															
5.0					5	2	SS	50	23		1.5				
7.0					5										
SILTY CLAY, trace sand & gravel, brown, stiff, (CL)															
7.0					3	3	SS	89	25		1.25				
End Of Boring															

WATER LEVEL OBSERVATIONS	
WL	▽ Dry
WL	▼
WL	▼

**Applied GeoScience, Inc.**  
 2385 Hammond Drive, Suite 6  
 Schaumburg, Illinois 60173  
 Tel: (847) 303-0300  
 Fax: (847) 303-0900

STARTED	1-30-15	FINISHED	1-30-15
DRILL CO.	Williams	DRILL RIG	45-C
DRILLER	Pecka	ASS'T DRILLER	
ENG/GEOL.	JG	APPROVED	AM

CLIENT: Village of Villa Park	PROJECT: 2015 Village of Villa Park Road Improvements
-------------------------------	---

ADDRESS: 44 N Cornell Ave (from Elm St to St Charles Rd)	LOCATION: Various Streets
--	---------------------------

COUNTY: DuPage	GRAPHIC LOG	SAMPLES				TESTS				
		DEPTH (FT.)	SPT-N BLOWS / FT.	NUMBER	TYPE	% RECOVERY	MOISTURE, %	HNu Units ppm	Qu tsf Failure Type	DRY DENSITY PCF
SURFACE ELEVATION Datum:										
6.25 inches of asphalt										
0.5										
14.75 inches of crushed limestone										
1.8										
SILTY CLAY, trace sand & gravel, brown & gray, frozen soil, (CL)										
2.5										
SILTY CLAY, trace sand & gravel, brown & gray, very stiff, (CL)										
5.3										
SILTY CLAY, trace sand & gravel, brown & gray, hard, (CL)										
7.0										
End Of Boring										

WATER LEVEL OBSERVATIONS	<b>Applied GeoScience, Inc.</b> 2385 Hammond Drive, Suite 6 Schaumburg, Illinois 60173 Tel: (847) 303-0300 Fax: (847) 303-0900	STARTED	1-30-15	FINISHED	1-30-15
WL ▽ Dry		DRILL CO.	Williams	DRILL RIG	45-C
WL ▼		DRILLER	Pecka	ASS'T DRILLER	
WL ▼		ENG/GEOL.	JG	APPROVED	AM

CLIENT: Village of Villa Park	PROJECT: 2015 Village of Villa Park Road Improvements
-------------------------------	---

ADDRESS: 18 N Cornell Ave (from Elm St to St Charles Rd)	LOCATION: Various Streets
--	---------------------------

COUNTY: DuPage	CITY & STATE: Villa Park, Illinois	SURFACE ELEVATION Datum:	GRAPHIC LOG	SAMPLES				TESTS							
				DEPTH (FT.)	SPT-N BLOWS / FT.	NUMBER	TYPE	% RECOVERY	MOISTURE, %	HNu Units ppm	Qu tsf	Failure Type	DRY DENSITY PCF	Est. Coefficient of Permeability k <sub>v</sub> (cm/sec)	
6 inches of asphalt			0.5												
8.75 inches of crushed limestone			1.2												
FILL, silty clay, trace sand & gravel, brown, frozen soil			1.8												
ORGANIC CLAY, black Organic Content = 7.5%			2.5	8	1	SS	50	21							
SILTY CLAY, trace sand & gravel, brown & gray, very stiff, (CL)			5.0	5	2	SS	50	19			2.6				
End Of Boring			7.0	9	3	SS	78	17			3.7				

WATER LEVEL OBSERVATIONS	
WL	▽ Dry
WL	▼
WL	▼

**Applied GeoScience, Inc.**  
 2385 Hammond Drive, Suite 6  
 Schaumburg, Illinois 60173  
 Tel: (847) 303-0300  
 Fax: (847) 303-0900

STARTED	1-30-15	FINISHED	1-30-15
DRILL CO.	Williams	DRILL RIG	45-C
DRILLER	Pecka	ASS'T DRILLER	
ENG/GEOL.	JG	APPROVED	AM

CLIENT: Village of Villa Park	PROJECT: 2015 Village of Villa Park Road Improvements
-------------------------------	---

ADDRESS: 148 W Division St (from Harvard Ave to Yale Ave)	LOCATION: Various Streets
---	---------------------------

COUNTY: DuPage	CITY & STATE: Villa Park, Illinois	SURFACE ELEVATION Datum:	GRAPHIC LOG	SAMPLES				TESTS						
				DEPTH (FT.)	SPT-N BLOWS / FT.	NUMBER	TYPE	% RECOVERY	MOISTURE, %	HNu Units ppm	Qu tsf	Failure Type	DRY DENSITY PCF	Est. Coefficient of Permeability k <sub>v</sub> (cm/sec)
7.25 inches of asphalt														
0.6														
10 inches of crushed limestone														
1.4														
SILTY CLAY, trace sand & gravel, brown & gray, frozen soil, (CL)														
2.5														
SILTY CLAY, trace sand & gravel, brown & gray, very stiff, (CL)														
7.0														
End Of Boring														

WATER LEVEL OBSERVATIONS	<b>Applied GeoScience, Inc.</b> 2385 Hammond Drive, Suite 6 Schaumburg, Illinois 60173 Tel: (847) 303-0300 Fax: (847) 303-0900	STARTED	1-30-15	FINISHED	1-30-15
WL ▽ Dry		DRILL CO.	Williams	DRILL RIG	45-C
WL ▼		DRILLER	Pecka	ASS'T DRILLER	
WL ▼		ENG/GEOL.	JG	APPROVED	AM

CLIENT: Village of Villa Park	PROJECT: 2015 Village of Villa Park Road Improvements
-------------------------------	---

ADDRESS: 126 W Division St (from Harvard Ave to Yale Ave)	LOCATION: Various Streets
---	---------------------------

COUNTY: DuPage	CITY & STATE: Villa Park, Illinois	SURFACE ELEVATION	Datum:	GRAPHIC LOG	SAMPLES				TESTS						
					DEPTH (FT.)	SPT-N BLOWS / FT.	NUMBER	TYPE	% RECOVERY	MOISTURE, %	HNu Units ppm	Qu tsf	Failure Type	DRY DENSITY PCF	Est. Coefficient of Permeability k <sub>v</sub> (cm/sec)
6 inches of asphalt				0.5											
7 inches of crushed limestone				1.1											
SILTY CLAY, trace sand & gravel, black & gray to brown & gray, frozen soil, (CL)				2.5		11	1	SS	78	22					
SILTY CLAY, trace sand & gravel, brown & gray, very stiff, (CL)				5.0		10	2	SS	67	21		2.3			
End Of Boring				7.0		13	3	SS	94	19		3			

WATER LEVEL OBSERVATIONS	
WL	▽ Dry
WL	▼
WL	▼

**Applied GeoScience, Inc.**  
 2385 Hammond Drive, Suite 6  
 Schaumburg, Illinois 60173  
 Tel: (847) 303-0300  
 Fax: (847) 303-0900

STARTED	1-30-15	FINISHED	1-30-15
DRILL CO.	Williams	DRILL RIG	45-C
DRILLER	Pecka	ASS'T DRILLER	
ENG/GEOL.	JG	APPROVED	AM

CLIENT: Village of Villa Park	PROJECT: 2015 Village of Villa Park Road Improvements
-------------------------------	---

ADDRESS: 111 W Division St (from Yale Ave to Princeton Ave)	LOCATION: Various Streets
---	---------------------------

COUNTY: DuPage	CITY & STATE: Villa Park, Illinois	SURFACE ELEVATION	Datum:	GRAPHIC LOG	SAMPLES				TESTS					
					DEPTH (FT.)	SPT-N BLOWS / FT.	NUMBER	TYPE	% RECOVERY	MOISTURE, %	HNu Units ppm	Qu tsf	Failure Type	DRY DENSITY PCF
6 inches of asphalt				0.5	8	1	SS	72	48					
5 inches of crushed limestone				0.9										
ORGANIC CLAY, black Organic Content = 7.4%				2.5										
SILTY CLAY, trace sand & gravel, brown & gray, stiff, (CL)				5.5	6	2	SS	67	24		1.7			
SILTY CLAY, trace sand & gravel, brown & gray, very stiff, (CL)				7.0	10	3	SS	100	20		3			
End Of Boring														

WATER LEVEL OBSERVATIONS	
WL	▽ Dry
WL	▼
WL	▼

**Applied GeoScience, Inc.**  
 2385 Hammond Drive, Suite 6  
 Schaumburg, Illinois 60173  
 Tel: (847) 303-0300  
 Fax: (847) 303-0900

STARTED	1-30-15	FINISHED	1-30-15
DRILL CO.	Williams	DRILL RIG	45-C
DRILLER	Pecka	ASS'T DRILLER	
ENG/GEOL.	JG	APPROVED	AM

CLIENT: Village of Villa Park	PROJECT: 2015 Village of Villa Park Road Improvements
-------------------------------	---

ADDRESS: 35 W Division St (from Yale Ave to Princeton Ave)	LOCATION: Various Streets
--	---------------------------

COUNTY: DuPage	GRAPHIC LOG	SAMPLES				TESTS				
		DEPTH (FT.)	SPT-N BLOWS / FT.	NUMBER	TYPE	% RECOVERY	MOISTURE, %	HNu Units ppm	Qu tsf Failure Type	DRY DENSITY PCF
SURFACE ELEVATION Datum:										
0.5 6.5 inches of asphalt										
1.0 5 inches of crushed limestone										
FILL, silty clay, with crushed stone										
Boring terminated at 3.5 ft due to possible utility conflict		19	1	SS	67	22		2.2		
3.5										
End Of Boring										

WATER LEVEL OBSERVATIONS	
WL	▽ Dry
WL	▼
WL	▼

**Applied GeoScience, Inc.**  
 2385 Hammond Drive, Suite 6  
 Schaumburg, Illinois 60173  
 Tel: (847) 303-0300  
 Fax: (847) 303-0900

STARTED	1-30-15	FINISHED	1-30-15
DRILL CO.	Williams	DRILL RIG	45-C
DRILLER	Pecka	ASS'T DRILLER	
ENG/GEOL.	JG	APPROVED	AM

CLIENT: Village of Villa Park	PROJECT: 2015 Village of Villa Park Road Improvements
-------------------------------	---

ADDRESS: 20 W Division St (from Princeton to Ardmore)	LOCATION: Various Streets
---	---------------------------

COUNTY: DuPage	GRAPHIC LOG	SAMPLES				TESTS					
		DEPTH (FT.)	SPT-N BLOWS / FT.	NUMBER	TYPE	% RECOVERY	MOISTURE, %	HNu Units ppm	Qu tsf	Failure Type	DRY DENSITY PCF
SURFACE ELEVATION Datum:											
6 inches of asphalt 0.5											
9 inches of crushed limestone 1.3											
ORGANIC CLAY, black Organic Content = 4.3% 2.0		9	1	SS	72	30					
SILTY CLAY, trace sand & gravel, brown & gray, stiff, (CL) 5.5		5	2	SS	67	26		1			
SILTY CLAY, trace sand & gravel, brown & gray, medium stiff, (CL) 7.0		3	3	SS	83	26		0.5			
End Of Boring											

WATER LEVEL OBSERVATIONS	
WL	▽ Dry
WL	▼
WL	▼

**Applied GeoScience, Inc.**  
 2385 Hammond Drive, Suite 6  
 Schaumburg, Illinois 60173  
 Tel: (847) 303-0300  
 Fax: (847) 303-0900

STARTED	1-30-15	FINISHED	1-30-15
DRILL CO.	Williams	DRILL RIG	45-C
DRILLER	Pecka	ASS'T DRILLER	
ENG/GEOL.	JG	APPROVED	AM

CLIENT: Village of Villa Park	PROJECT: 2015 Village of Villa Park Road Improvements
-------------------------------	---

ADDRESS: 824 Ellsworth Ave (from Armitage Ave to 660 ft)	LOCATION: Various Streets
--	---------------------------

COUNTY: DuPage	GRAPHIC LOG	SAMPLES				TESTS						
		DEPTH (FT.)	SPT-N BLOWS / FT.	NUMBER	TYPE	% RECOVERY	MOISTURE, %	HNu Units ppm	Qu tsf	Failure Type	DRY DENSITY PCF	Est. Coefficient of Permeability k <sub>v</sub> (cm/sec)
SURFACE ELEVATION Datum:												
8 inches of concrete 0.7	▽▽▽▽											
1.0 4 inches of crushed limestone	□□□□											
FILL, silty clay, trace sand & gravel, brown & gray, frozen soil	▨▨▨▨	10	1	SS	83	19						
3.0	▨▨▨▨	14	2	SS	100	19		3.1				
SILTY CLAY, trace sand & gravel, brown & gray, very stiff, (CL)	▨▨▨▨	17	3	SS	94	18		3.5				
7.0	▨▨▨▨											
End Of Boring												

WATER LEVEL OBSERVATIONS	
WL	▽ Dry
WL	▼
WL	▼

**Applied GeoScience, Inc.**  
 2385 Hammond Drive, Suite 6  
 Schaumburg, Illinois 60173  
 Tel: (847) 303-0300  
 Fax: (847) 303-0900

STARTED	1-29-15	FINISHED	1-29-15
DRILL CO.	GBE	DRILL RIG	CME-75
DRILLER	Gabe	ASS'T DRILLER	
ENG/GEOL.	JG	APPROVED	AM

CLIENT: Village of Villa Park	PROJECT: 2015 Village of Villa Park Road Improvements
-------------------------------	---

ADDRESS: 854 Ellsworth Ave (from Armitage Ave to 660 ft)	LOCATION: Various Streets
--	---------------------------

COUNTY: DuPage  CITY & STATE: Villa Park, Illinois  SURFACE ELEVATION Datum:	GRAPHIC LOG	SAMPLES				TESTS				
		DEPTH (FT.)	SPT-N BLOWS / FT.	NUMBER	TYPE	% RECOVERY	MOISTURE, %	HNu Units ppm	Qu tsf Failure Type	DRY DENSITY PCF
7.75 inches of concrete 0.6										
7 inches of crushed limestone 1.2										
FILL, silty clay, trace sand & gravel, brown & gray, frozen soil  3.0		12	1	SS	72	18				
SILTY CLAY, trace sand & gravel, brown, very stiff, (CL)  5.0		11	2	SS	10	19		2.4		
7.0		14	3	SS	100	16		3.3		
End Of Boring										

WATER LEVEL OBSERVATIONS	<b>Applied GeoScience, Inc.</b> 2385 Hammond Drive, Suite 6 Schaumburg, Illinois 60173 Tel: (847) 303-0300 Fax: (847) 303-0900	STARTED	1-29-15	FINISHED	1-29-15
WL ▽ Dry		DRILL CO.	GBE	DRILL RIG	CME-75
WL ▼		DRILLER	Gabe	ASS'T DRILLER	
WL ▼		ENG/GEOL.	JG	APPROVED	AM

CLIENT: Village of Villa Park	PROJECT: 2015 Village of Villa Park Road Improvements
-------------------------------	---

ADDRESS: 904 Ellsworth Ave (from 660 ft to Sidney Ct)	LOCATION: Various Streets
---	---------------------------

COUNTY: DuPage  CITY & STATE: Villa Park, Illinois  SURFACE ELEVATION Datum:	GRAPHIC LOG	DEPTH (FT.)	SAMPLES				TESTS				
			SPT-N BLOWS / FT.	NUMBER	TYPE	% RECOVERY	MOISTURE, %	HNu Units ppm	Qu tsf	Failure Type	DRY DENSITY PCF
7.75 inches of concrete 0.6	▽▽▽										
~22.25 inches of crushed limestone  2.5	●●●		25	1	SS	72					
SILTY CLAY, trace sand & gravel, brown & gray, stiff, (CL)  5.5	▨▨▨		6	2	SS	56	28		1		
SILTY CLAY, trace sand & gravel, brown & gray, soft, (CL)  7.0	▨▨▨		3	3	SS	67	32		0.2		
End Of Boring											

WATER LEVEL OBSERVATIONS	<b>Applied GeoScience, Inc.</b> 2385 Hammond Drive, Suite 6 Schaumburg, Illinois 60173 Tel: (847) 303-0300 Fax: (847) 303-0900	STARTED 1-29-15	FINISHED 1-29-15
WL ▽ Dry		DRILL CO. GBE	DRILL RIG CME-75
WL ▼		DRILLER Gabe	ASS'T DRILLER
WL ▼		ENG/GEOL. JG	APPROVED AM

CLIENT: Village of Villa Park	PROJECT: 2015 Village of Villa Park Road Improvements
-------------------------------	---

ADDRESS: 932 Ellsworth Ave (from 660 ft to Sidney Ct)	LOCATION: Various Streets
---	---------------------------

COUNTY: DuPage  CITY & STATE: Villa Park, Illinois  SURFACE ELEVATION Datum:	GRAPHIC LOG	SAMPLES				TESTS					
		DEPTH (FT.)	SPT-N BLOWS / FT.	NUMBER	TYPE	% RECOVERY	MOISTURE, %	HNu Units ppm	Qu tsf	Failure Type	DRY DENSITY PCF
7.75 inches of concrete 0.6											
13 inches of crushed limestone 1.7											
FILL, silty clay, trace sand & gravel, dark brown, frozen soil 3.0		44	1	SS	100	26					
SILTY CLAY, trace sand & gravel, brown, very stiff, (CL) 5.0		10	2	SS	67	21		2.3			
7.0		9	3	SS	83	23		2.1			
End Of Boring											

WATER LEVEL OBSERVATIONS	
WL	▽ Dry
WL	▼
WL	▼

**Applied GeoScience, Inc.**  
 2385 Hammond Drive, Suite 6  
 Schaumburg, Illinois 60173  
 Tel: (847) 303-0300  
 Fax: (847) 303-0900

STARTED	1-29-15	FINISHED	1-29-15
DRILL CO.	GBE	DRILL RIG	CME-75
DRILLER	Gabe	ASS'T DRILLER	
ENG/GEOL.	JG	APPROVED	AM

CLIENT: Village of Villa Park	PROJECT: 2015 Village of Villa Park Road Improvements
-------------------------------	---

ADDRESS: 995 Ellsworth Ave (from Sidney Ct to Adele Ct)	LOCATION: Various Streets
---	---------------------------

COUNTY: DuPage	GRAPHIC LOG	SAMPLES				TESTS						
		DEPTH (FT.)	SPT-N BLOWS / FT.	NUMBER	TYPE	% RECOVERY	MOISTURE, %	HNu Units ppm	Qu tsf	Failure Type	DRY DENSITY PCF	Est. Coefficient of Permeability k <sub>v</sub> (cm/sec)
7.75 inches of concrete	▽▽▽											
0.6												
15.25 inches of crushed limestone	●●●											
1.9												
FILL, silty clay, trace sand & gravel, brown & black, frozen soil	▨▨▨											
3.0												
SILTY CLAY, trace sand & gravel, brown & gray, stiff, (CL)	▨▨▨											
5												
7.0												
End Of Boring												

WATER LEVEL OBSERVATIONS	<b>Applied GeoScience, Inc.</b>	STARTED	1-29-15	FINISHED	1-29-15
WL ▽ Dry	2385 Hammond Drive, Suite 6 Schaumburg, Illinois 60173 Tel: (847) 303-0300 Fax: (847) 303-0900	DRILL CO.	GBE	DRILL RIG	CME-75
WL ▼		DRILLER	Gabe	ASS'T DRILLER	
WL ▼		ENG/GEOL.	JG	APPROVED	AM

CLIENT: Village of Villa Park	PROJECT: 2015 Village of Villa Park Road Improvements
-------------------------------	---

ADDRESS: 1022 Ellsworth Ave (from Sidney Ct to Adele Ct)	LOCATION: Various Streets
--	---------------------------

COUNTY: DuPage	GRAPHIC LOG	SAMPLES				TESTS				
		DEPTH (FT.)	SPT-N BLOWS / FT.	NUMBER	TYPE	% RECOVERY	MOISTURE, %	HNu Units ppm	Qu tsf Failure Type	DRY DENSITY PCF
SURFACE ELEVATION Datum:										
8 inches of concrete 0.7	▽									
1.0 4 inches of crushed limestone	▴									
FILL, silty clay, trace sand & gravel, brown, frozen soil 2.5	▨	8	1	SS	94	25				
SILTY CLAY, trace sand & gravel, brown, very stiff, (CL) 5	▧	12	2	SS	83	18		3.2		
7.0	▩	10	3	SS	89	21		2.3		
End Of Boring										

WATER LEVEL OBSERVATIONS	
WL	▽ Dry
WL	▼
WL	▼

**Applied GeoScience, Inc.**  
 2385 Hammond Drive, Suite 6  
 Schaumburg, Illinois 60173  
 Tel: (847) 303-0300  
 Fax: (847) 303-0900

STARTED	1-29-15	FINISHED	1-29-15
DRILL CO.	GBE	DRILL RIG	CME-75
DRILLER	Gabe	ASS'T DRILLER	
ENG/GEOL.	JG	APPROVED	AM

CLIENT: Village of Villa Park	PROJECT: 2015 Village of Villa Park Road Improvements
-------------------------------	---

ADDRESS: 875 Ellsworth Ave (from Adele Ct to 660 ft)	LOCATION: Various Streets
--	---------------------------

COUNTY: DuPage	GRAPHIC LOG	SAMPLES				TESTS					
		DEPTH (FT.)	SPT-N BLOWS / FT.	NUMBER	TYPE	% RECOVERY	MOISTURE, %	HNu Units ppm	Qu tsf	Failure Type	DRY DENSITY PCF
SURFACE ELEVATION Datum:											
8 inches of concrete 0.7	▽▽▽▽										
~22 inches of crushed limestone 2.5	●●●●										
FILL, silty clay, trace sand & gravel, brown & gray 3.0	▨▨▨▨										
SILTY CLAY, trace sand & gravel, brown, stiff, (CL)	▨▨▨▨										
5		5	2	SS	94	26		1.3			
7.0		6	3	SS	89	27		1			
End Of Boring											

WATER LEVEL OBSERVATIONS	
WL	▽ Dry
WL	▼
WL	▼

**Applied GeoScience, Inc.**  
 2385 Hammond Drive, Suite 6  
 Schaumburg, Illinois 60173  
 Tel: (847) 303-0300  
 Fax: (847) 303-0900

STARTED	1-29-15	FINISHED	1-29-15
DRILL CO.	GBE	DRILL RIG	CME-75
DRILLER	Gabe	ASS'T DRILLER	
ENG/GEOL.	JG	APPROVED	AM

CLIENT: Village of Villa Park	PROJECT: 2015 Village of Villa Park Road Improvements
-------------------------------	---

ADDRESS: 865 Ellsworth Ave (from Adele Ct to 660 ft)	LOCATION: Various Streets
--	---------------------------

COUNTY: DuPage  CITY & STATE: Villa Park, Illinois  SURFACE ELEVATION Datum:	GRAPHIC LOG	SAMPLES				TESTS					
		DEPTH (FT.)	SPT-N BLOWS / FT.	NUMBER	TYPE	% RECOVERY	MOISTURE, %	HNu Units ppm	Qu tsf	Failure Type	DRY DENSITY PCF
7.75 inches of concrete 0.6											
~22.25 inches of crushed limestone  2.5		41	1	SS	83						
FILL, silty clay, trace sand & gravel, brown & black, stiff  5.0		9	2	SS	44	29		1.3			
SILTY CLAY, trace sand & gravel, brown & gray, medium stiff, (CL)  7.0		5	3	SS	78	31		0.7			
End Of Boring											

WATER LEVEL OBSERVATIONS	
WL	▽ Dry
WL	▼
WL	▼

**Applied GeoScience, Inc.**  
 2385 Hammond Drive, Suite 6  
 Schaumburg, Illinois 60173  
 Tel: (847) 303-0300  
 Fax: (847) 303-0900

STARTED	1-29-15	FINISHED	1-29-15
DRILL CO.	GBE	DRILL RIG	CME-75
DRILLER	Gabe	ASS'T DRILLER	
ENG/GEOL.	JG	APPROVED	AM

CLIENT: Village of Villa Park	PROJECT: 2015 Village of Villa Park Road Improvements
-------------------------------	---

ADDRESS: 150 North Ave (from 660 ft to North Ave)	LOCATION: Various Streets
---	---------------------------

COUNTY: DuPage	GRAPHIC LOG	SAMPLES					TESTS				
		DEPTH (FT.)	SPT-N BLOWS / FT.	NUMBER	TYPE	% RECOVERY	MOISTURE, %	HNu Units ppm	Qu tsf	Failure Type	DRY DENSITY PCF
SURFACE ELEVATION Datum: 10.25 inches concrete over crushed limestone 0.9 Boring terminated. Auger refusal due to steel rebar. End Of Boring											

WATER LEVEL OBSERVATIONS	<b>Applied GeoScience, Inc.</b> 2385 Hammond Drive, Suite 6 Schaumburg, Illinois 60173 Tel: (847) 303-0300 Fax: (847) 303-0900	STARTED	1-29-15	FINISHED	1-29-15
WL ▽ Dry		DRILL CO.	GBE	DRILL RIG	CME-75
WL ▼		DRILLER	Gabe	ASS'T DRILLER	
WL ▼		ENG/GEOL.	JG	APPROVED	AM

CLIENT: Village of Villa Park	PROJECT: 2015 Village of Villa Park Road Improvements
-------------------------------	---

ADDRESS: 609 Grant Ave (from Washington Blvd to South End)	LOCATION: Various Streets
--	---------------------------

COUNTY: DuPage	CITY & STATE: Villa Park, Illinois	SURFACE ELEVATION Datum:	GRAPHIC LOG	SAMPLES				TESTS					
				DEPTH (FT.)	SPT-N BLOWS / FT.	NUMBER	TYPE	% RECOVERY	MOISTURE, %	HNu Units ppm	Qu tsf	Failure Type	DRY DENSITY PCF
0.2 2.25 inches of asphalt													
9.75 inches of crushed limestone													
1.0 ORGANIC CLAY, black Organic Content = 3.1%				10	1	SS	83	29					
2.5 SILTY CLAY, trace sand & gravel, brown, stiff, (CL)				6	2	SS	78	27		1.3			
7.0				6	3	SS	56	28		1			
End Of Boring													

WATER LEVEL OBSERVATIONS	<b>Applied GeoScience, Inc.</b> 2385 Hammond Drive, Suite 6 Schaumburg, Illinois 60173 Tel: (847) 303-0300 Fax: (847) 303-0900	STARTED	1-30-15	FINISHED	1-30-15
WL ▽ Dry		DRILL CO.	GBE	DRILL RIG	CME-75
WL ▼		DRILLER	Gabe	ASS'T DRILLER	
WL ▼		ENG/GEOL.	JG	APPROVED	AM

CLIENT: Village of Villa Park	PROJECT: 2015 Village of Villa Park Road Improvements
-------------------------------	---

ADDRESS: 630 Grant Ave (from Washington Blvd to South End)	LOCATION: Various Streets
--	---------------------------

COUNTY: DuPage	GRAPHIC LOG	SAMPLES				TESTS					
		DEPTH (FT.)	SPT-N BLOWS / FT.	NUMBER	TYPE	% RECOVERY	MOISTURE, %	HNu Units ppm	Qu tsf	Failure Type	DRY DENSITY PCF
SURFACE ELEVATION Datum: 0.3 3 inches of asphalt 19 inches of crushed limestone		0.3 1.8 2.5 5 7.0		1 2 3	SS SS SS	50 72 100	18 16 23	3.1 2			
CITY & STATE: Villa Park, Illinois  SILTY CLAY, trace sand & gravel, brown, frozen soil, (CL) SILTY CLAY, trace sand & gravel, brown, very stiff, (CL)											
End Of Boring											

WATER LEVEL OBSERVATIONS	<b>Applied GeoScience, Inc.</b>	STARTED	1-30-15	FINISHED	1-30-15
WL ▽ Dry	2385 Hammond Drive, Suite 6	DRILL CO.	GBE	DRILL RIG	CME-75
WL ▼	Schaumburg, Illinois 60173	DRILLER	Gabe	ASS'T DRILLER	
WL ▼	Tel: (847) 303-0300 Fax: (847) 303-0900	ENG/GEOL.	JG	APPROVED	AM

CLIENT: Village of Villa Park	PROJECT: 2015 Village of Villa Park Road Improvements
-------------------------------	---

ADDRESS: 149 W St Charles Rd (Harvard to Pvmt Change)	LOCATION: Various Streets
---	---------------------------

COUNTY: DuPage	CITY & STATE: Villa Park, Illinois	SURFACE ELEVATION	Datum:	GRAPHIC LOG	SAMPLES				TESTS						
					DEPTH (FT.)	SPT-N BLOWS / FT.	NUMBER	TYPE	% RECOVERY	MOISTURE, %	HNu Units ppm	Qu tsf	Failure Type	DRY DENSITY PCF	Est. Coefficient of Permeability k <sub>v</sub> (cm/sec)
0.4 5.25 inches of asphalt				█											
7.75 inches of recycled stone				█											
1.1 ORGANIC CLAY, black Organic Content = 6.6%				█	12	1	SS	83	37						
2.5 SILTY CLAY, trace sand & gravel, brown, very stiff, (CL)				█	12	2	SS	67	21		2.2				
7.0 End Of Boring				█	10	3	SS	78	19		2.5				

WATER LEVEL OBSERVATIONS		<b>Applied GeoScience, Inc.</b> 2385 Hammond Drive, Suite 6 Schaumburg, Illinois 60173 Tel: (847) 303-0300 Fax: (847) 303-0900	STARTED	1-30-15	FINISHED	1-30-15
WL	▽ Dry		DRILL CO.	GBE	DRILL RIG	CME-75
WL	▼		DRILLER	Gabe	ASS'T DRILLER	
WL	▼		ENG/GEOL.	JG	APPROVED	AM

CLIENT: Village of Villa Park	PROJECT: 2015 Village of Villa Park Road Improvements
-------------------------------	---

ADDRESS: 125 W St Charles Rd (Harvard to Pvmt Change)	LOCATION: Various Streets
---	---------------------------

COUNTY: DuPage	CITY & STATE: Villa Park, Illinois	SURFACE ELEVATION	Datum:	GRAPHIC LOG	SAMPLES				TESTS					
					DEPTH (FT.)	SPT-N BLOWS / FT.	NUMBER	TYPE	% RECOVERY	MOISTURE, %	HNu Units ppm	Qu tsf	Failure Type	DRY DENSITY PCF
0.3 4 inches of asphalt														
8 inches of recycled stone														
1.0														
ORGANIC CLAY, black Organic Content = 9.5%														
2.5														
SILTY CLAY, trace sand & gravel, brown, stiff, (CL)														
7.0				19	1	SS	78	39						
End Of Boring				6	2	SS	78	23			1.3			
				9	3	SS	67	25			1.5			

WATER LEVEL OBSERVATIONS	<b>Applied GeoScience, Inc.</b> 2385 Hammond Drive, Suite 6 Schaumburg, Illinois 60173 Tel: (847) 303-0300 Fax: (847) 303-0900	STARTED	1-30-15	FINISHED	1-30-15
WL ▽ Dry		DRILL CO.	GBE	DRILL RIG	CME-75
WL ▼		DRILLER	Gabe	ASS'T DRILLER	
WL ▼		ENG/GEOL.	JG	APPROVED	AM

CLIENT: Village of Villa Park	PROJECT: 2015 Village of Villa Park Road Improvements
-------------------------------	---

ADDRESS: 55A W St Charles Rd (Harvard to Pvmnt Change)	LOCATION: Various Streets
--	---------------------------

COUNTY: DuPage	CITY & STATE: Villa Park, Illinois	SURFACE ELEVATION Datum:	GRAPHIC LOG	SAMPLES				TESTS							
				DEPTH (FT.)	SPT-N BLOWS / FT.	NUMBER	TYPE	% RECOVERY	MOISTURE, %	HNu Units ppm	Qu tsf	Failure Type	DRY DENSITY PCF	Est. Coefficient of Permeability k <sub>v</sub> (cm/sec)	
0.3 3 inches of asphalt															
9 inches of recycled stone															
1.0 SILTY CLAY, trace sand & gravel, brown, frozen soil, (CL)				17	1	SS	89	23							
2.5 SILTY CLAY, trace sand & gravel, brown, stiff, (CL)				5	2	SS	78	24			1.3				
7.0 End Of Boring				5	3	SS	100	26			1				

WATER LEVEL OBSERVATIONS	
WL	▽ Dry
WL	▼
WL	▼

**Applied GeoScience, Inc.**  
 2385 Hammond Drive, Suite 6  
 Schaumburg, Illinois 60173  
 Tel: (847) 303-0300  
 Fax: (847) 303-0900

STARTED	1-30-15	FINISHED	1-30-15
DRILL CO.	GBE	DRILL RIG	CME-75
DRILLER	Gabe	ASS'T DRILLER	
ENG/GEOL.	JG	APPROVED	AM

CLIENT: Village of Villa Park	PROJECT: 2015 Village of Villa Park Road Improvements
-------------------------------	---

ADDRESS: 28 Home Ave (from Pvmt Change to Ardmore)	LOCATION: Various Streets
--	---------------------------

COUNTY: DuPage	CITY & STATE: Villa Park, Illinois	SURFACE ELEVATION Datum:	GRAPHIC LOG	SAMPLES				TESTS						
				DEPTH (FT.)	SPT-N BLOWS / FT.	NUMBER	TYPE	% RECOVERY	MOISTURE, %	HNu Units ppm	Qu tsf	Failure Type	DRY DENSITY PCF	Est. Coefficient of Permeability k <sub>v</sub> (cm/sec)
0.4 4.75 inches of asphalt			█											
9.75 inches of recycled stone			█											
1.2 FILL, silty clay, trace sand & gravel, brown & black, frozen soil			█	20	1	SS	39	21						
2.5 SILTY CLAY, trace sand & gravel, brown, very stiff, (CL)			█	11	2	SS	94	17		3.1				
7.0 End Of Boring			█	11	3	SS	89	24		2				

WATER LEVEL OBSERVATIONS	
WL	▽ Dry
WL	▼
WL	▼

**Applied GeoScience, Inc.**  
 2385 Hammond Drive, Suite 6  
 Schaumburg, Illinois 60173  
 Tel: (847) 303-0300  
 Fax: (847) 303-0900

STARTED	1-30-15	FINISHED	1-30-15
DRILL CO.	GBE	DRILL RIG	CME-75
DRILLER	Gabe	ASS'T DRILLER	
ENG/GEOL.	JG	APPROVED	AM

CLIENT: Village of Villa Park	PROJECT: 2015 Village of Villa Park Road Improvements
-------------------------------	---

ADDRESS: 20 S Ardmore Ave (from Pvmt Change to Ardmore)	LOCATION: Various Streets
---	---------------------------

COUNTY: DuPage	GRAPHIC LOG	SAMPLES				TESTS					
		DEPTH (FT.)	SPT-N BLOWS / FT.	NUMBER	TYPE	% RECOVERY	MOISTURE, %	HNu Units ppm	Qu tsf	Failure Type	DRY DENSITY PCF
SURFACE ELEVATION Datum:											
5.5 inches of asphalt 0.5											
15.5 inches of crushed limestone 1.8											
FILL, silty clay, trace sand & gravel, brown & black, frozen soil 3.0		34	1	SS	94	24					
SILTY CLAY, trace sand & gravel, brown, very stiff, (CL) 5.0		8	2	SS	78	19		2.4			
7.0		12	3	SS	78	21		2.5			
End Of Boring											

WATER LEVEL OBSERVATIONS	
WL	▽ Dry
WL	▼
WL	▼

**Applied GeoScience, Inc.**  
 2385 Hammond Drive, Suite 6  
 Schaumburg, Illinois 60173  
 Tel: (847) 303-0300  
 Fax: (847) 303-0900

STARTED	1-30-15	FINISHED	1-30-15
DRILL CO.	GBE	DRILL RIG	CME-75
DRILLER	Gabe	ASS'T DRILLER	
ENG/GEOL.	JG	APPROVED	AM

AGI Job No. 14-345

**BORING LOG NO. B-32**

Sheet 1 of 1

CLIENT: Village of Villa Park

PROJECT: 2015 Village of Villa Park Road Improvements

ADDRESS: 995 Ellsworth Ave (from Ellsworth Ave to East End)

LOCATION: Various Streets

COUNTY: DuPage

CITY & STATE: Villa Park, Illinois

SURFACE ELEVATION Datum:

GRAPHIC LOG

DEPTH (FT.)	SAMPLES				TESTS				
	SPT-N BLOWS / FT.	NUMBER	TYPE	% RECOVERY	MOISTURE, %	HNu Units ppm	Qu tsf Failure Type	DRY DENSITY PCF	Est. Coefficient of Permeability k <sub>v</sub> (cm/sec)
0.7									
2.0	18	1	SS	89	24				
5.0	8	2	SS	83	17		2.5		
7.0	18	3	SS	100	17		3.3		

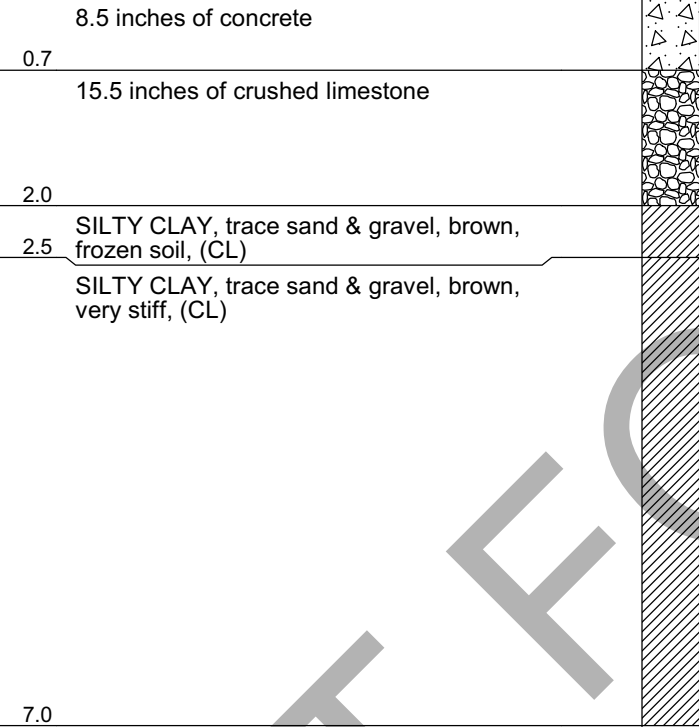

WATER LEVEL OBSERVATIONS

WL	∇	Dry
WL	▼	
WL	▼	

**Applied GeoScience, Inc.**

2385 Hammond Drive, Suite 6  
 Schaumburg, Illinois 60173  
 Tel: (847) 303-0300  
 Fax: (847) 303-0900

STARTED	1-29-15	FINISHED	1-29-15
DRILL CO.	GBE	DRILL RIG	CME-75
DRILLER	Gabe	ASS'T DRILLER	
ENG/GEOL.	JG	APPROVED	AM

CLIENT: Village of Villa Park	PROJECT: 2015 Village of Villa Park Road Improvements
-------------------------------	---

ADDRESS: 236 E Sidney Ct (from Ellsworth Ave to East End)	LOCATION: Various Streets
---	---------------------------

COUNTY: DuPage	GRAPHIC LOG	SAMPLES				TESTS				
		DEPTH (FT.)	SPT-N BLOWS / FT.	NUMBER	TYPE	% RECOVERY	MOISTURE, %	HNu Units ppm	Qu tsf Failure Type	DRY DENSITY PCF
SURFACE ELEVATION Datum:										
8 inches of concrete 0.7										
~28 inches of crushed limestone										
3.0		50	1	SS	89					
SILTY CLAY, trace sand & gravel, brown & gray, stiff, (CL)										
5.0		11	2	SS	22	26		1.5		
7.0		7	3	SS	78	27		1		
End Of Boring										

WATER LEVEL OBSERVATIONS	
WL	▽ Dry
WL	▼
WL	▼

**Applied GeoScience, Inc.**  
 2385 Hammond Drive, Suite 6  
 Schaumburg, Illinois 60173  
 Tel: (847) 303-0300  
 Fax: (847) 303-0900

STARTED	1-29-15	FINISHED	1-29-15
DRILL CO.	GBE	DRILL RIG	CME-75
DRILLER	Gabe	ASS'T DRILLER	
ENG/GEOL.	JG	APPROVED	AM

CLIENT: Village of Villa Park	PROJECT: 2015 Village of Villa Park Road Improvements
-------------------------------	---

ADDRESS: 112 W Division St (from North End to Division St)	LOCATION: Various Streets
--	---------------------------

COUNTY: DuPage	CITY & STATE: Villa Park, Illinois	SURFACE ELEVATION	Datum:	GRAPHIC LOG	DEPTH (FT.)	SAMPLES				TESTS								
						SPT-N BLOWS / FT.	NUMBER	TYPE	% RECOVERY	MOISTURE, %	H <sub>Nu</sub> Units ppm	Q <sub>u</sub> tsf	Failure Type	DRY DENSITY PCF	Est. Coefficient of Permeability k <sub>v</sub> (cm/sec)			
0.3	3.25 inches of asphalt																	
	11.5 inches of crushed limestone																	
1.3	Boring terminated due to possible utility conflict																	
	End Of Boring																	

WATER LEVEL OBSERVATIONS	<b>Applied GeoScience, Inc.</b> 2385 Hammond Drive, Suite 6 Schaumburg, Illinois 60173 Tel: (847) 303-0300 Fax: (847) 303-0900	STARTED	1-30-15	FINISHED	1-30-15
WL ▽ Dry		DRILL CO.	Williams	DRILL RIG	45-C
WL ▼		DRILLER	Pecka	ASS'T DRILLER	
WL ▼		ENG/GEOL.	JG	APPROVED	AM

**APPENDIX C**

**Pavement Coring Diagrams**

NOT FOR BID

NOT FOR BID

**2015 Village of Villa Park Road Improvements - Pavement Corings**

**Adele Court from Ellsworth Avenue to the East End (C-1 to C-2)**

CORE C-1 226 East Adele Court			Diagram
	Thickness (in)	Condition	
Total Pavement (Concrete)	8.25	Fair to Good	
Subbase	~ 21.75	Crushed Limestone	

CORE C-2 235 East Adele Court			Diagram
	Thickness (in)	Condition	
Total Pavement (Concrete)	8.00	Fair	
Subbase	~ 22.00	Crushed Limestone	

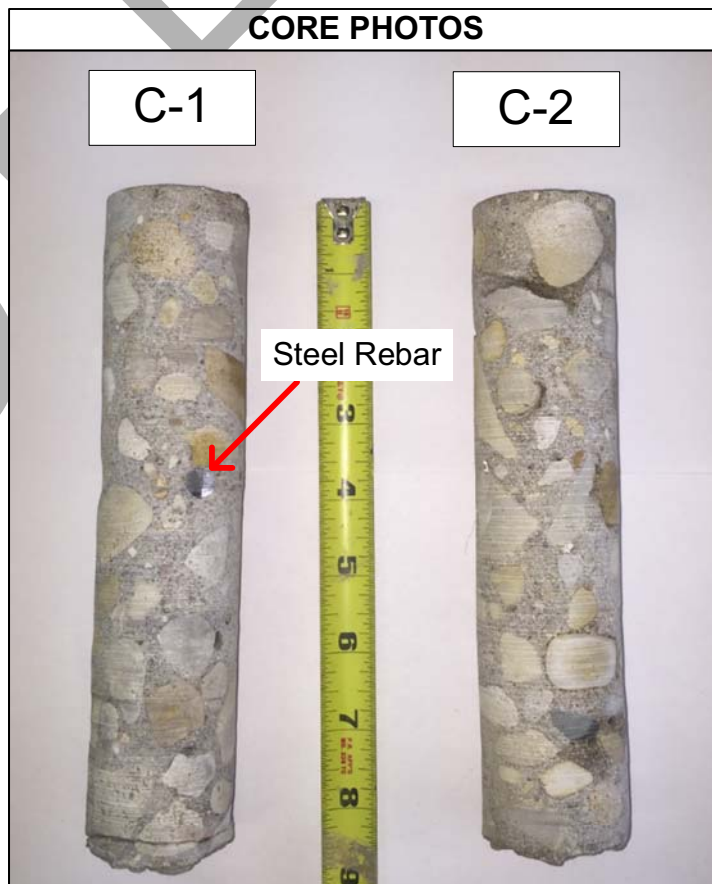

**2015 Village of Villa Park Road Improvements - Pavement Corings**

**North Cornell Avenue from the Metra Parking Lot to Division Street (C-3 to C-4)**

<b>CORE C-3</b> <b>328 North Cornell Avenue</b>			Diagram
	Thickness (in)	Condition	
Surface	2.25	Fair	
Binder	3.25	Fair	
<b>Total Pavement</b>	<b>5.50</b>		
Subbase	7.50	Crushed Limestone	

<b>CORE C-4</b> <b>239 North Cornell Avenue</b>			Diagram
	Thickness (in)	Condition	
Surface	1.75	Fair	
Binder	4.25	Fair	
<b>Total Pavement</b>	<b>6.00</b>		
Subbase	15.00	Crushed Limestone	

**CORE PHOTOS**



**2015 Village of Villa Park Road Improvements - Pavement Corings**

**North Cornell Avenue from Division Street to Oak Street (C-5 to C-6)**

<b>CORE C-5</b> <b>222 North Cornell Avenue</b>		
	Thickness (in)	Condition
Surface	2.00	Fair to Good
Binder	3.75	Fair
<b>Total Pavement</b>	<b>5.75</b>	
Subbase	11.00	Crushed Limestone

Diagram

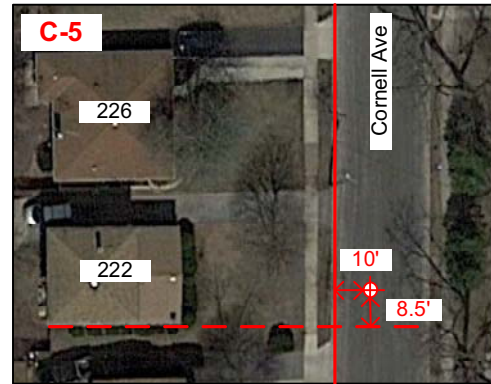

<b>CORE C-6</b> <b>206 North Cornell Avenue</b>		
	Thickness (in)	Condition
Surface	2.00	Fair to Good
Binder	4.50	Fair
<b>Total Pavement</b>	<b>6.50</b>	
Subbase	4.00	Crushed Limestone

Diagram

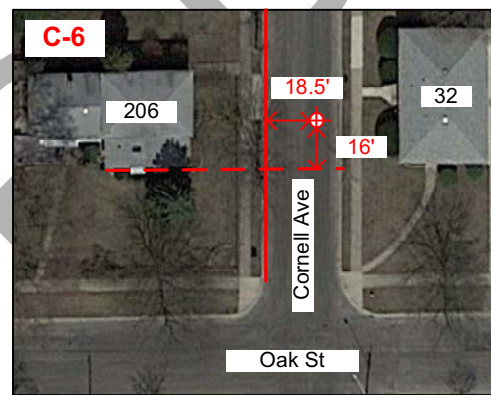

**CORE PHOTOS**



**2015 Village of Villa Park Road Improvements - Pavement Corings**

**North Cornell Avenue from Oak Street to Elm Street (C-7 to C-8)**

CORE C-7 134 North Cornell Avenue			Diagram
	Thickness (in)	Condition	
Surface	2.00	Good	
Binder	4.00	Fair	
<b>Total Pavement</b>	<b>6.00</b>		
Subbase	10.50	Crushed Limestone	

CORE C-8 110 North Cornell Avenue			Diagram
	Thickness (in)	Condition	
Surface	3.25	Fair to Good	
Binder	4.00	Fair	
<b>Total Pavement</b>	<b>7.25</b>		
Subbase	17.00	Crushed Limestone	

**CORE PHOTOS**

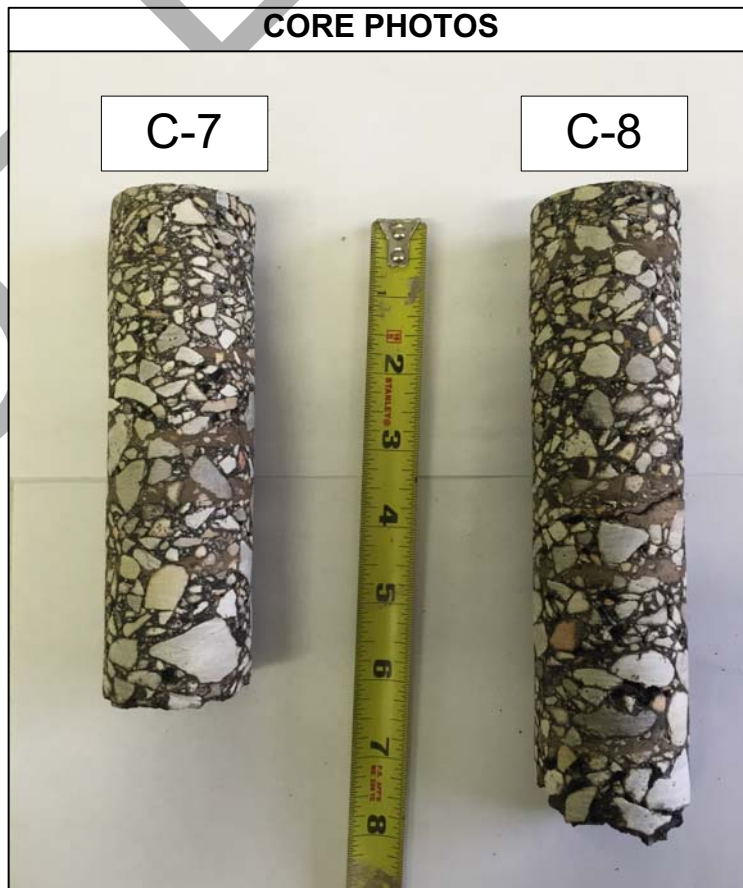

**2015 Village of Villa Park Road Improvements - Pavement Corings**

**North Cornell Avenue from Elm Street to St. Charles Road (C-9 to C-10)**

<b>CORE C-9</b> <b>44 North Cornell Avenue</b>		
	Thickness (in)	Condition
Surface	2.00	Fair to Good
Binder	4.25	Fair
<b>Total Pavement</b>	<b>6.25</b>	
Subbase	14.75	Crushed Limestone

Diagram

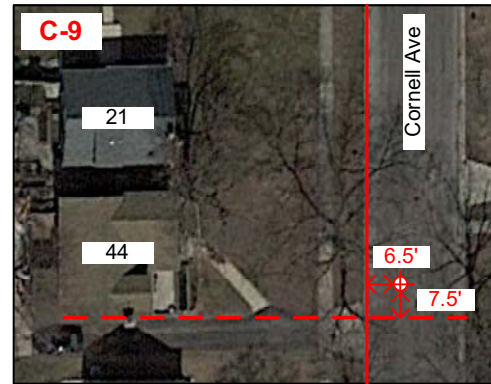

<b>CORE C-10</b> <b>18 North Cornell Avenue</b>		
	Thickness (in)	Condition
Surface	2.00	Fair
Binder	4.00	Poor
<b>Total Pavement</b>	<b>6.00</b>	
Subbase	8.75	Crushed Limestone

Diagram



**CORE PHOTOS**



**2015 Village of Villa Park Road Improvements - Pavement Corings**

**West Division Street from Harvard Avenue to Yale Avenue (C-11 to C-12)**

**CORE C-11  
148 West Division Street**

	Thickness (in)	Condition
Surface	2.75	Fair to Good
Binder	4.50	Fair
<b>Total Pavement</b>	<b>7.25</b>	
Subbase	10.00	Crushed Limestone

Diagram

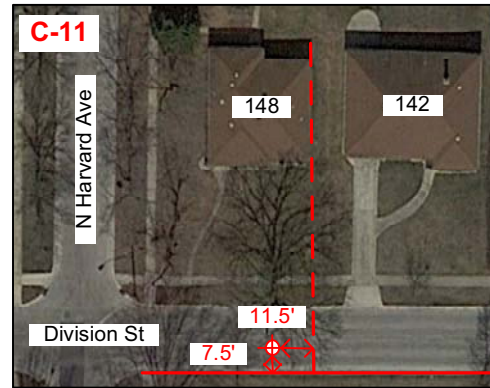

**CORE C-12  
126 West Division Street**

	Thickness (in)	Condition
Surface	2.00	Good
Binder	4.00	Fair to Good
<b>Total Pavement</b>	<b>6.00</b>	
Subbase	7.00	Crushed Limestone

Diagram

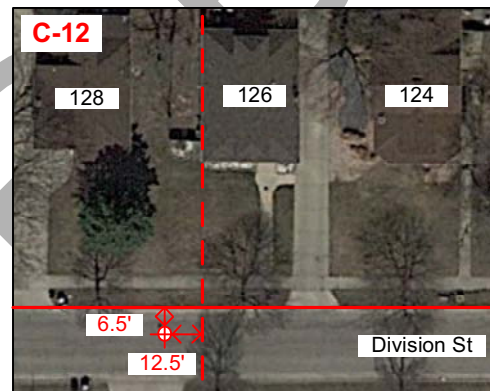

**CORE PHOTOS**



**2015 Village of Villa Park Road Improvements - Pavement Corings**

**West Division Street from Yale Avenue to Princeton Avenue (C-13 to C-14)**

**CORE C-13  
111 West Division Street**

	Thickness (in)	Condition
Surface	2.75	Fair to Good
Binder	3.25	Fair to Good
<b>Total Pavement</b>	<b>6.00</b>	
Subbase	5.00	Crushed Limestone

Diagram



**CORE C-14  
35 West Division Street**

	Thickness (in)	Condition
Surface	2.75	Good
Binder	3.75	Fair to Good
<b>Total Pavement</b>	<b>6.50</b>	
Subbase	5.00	Crushed Limestone

Diagram



**CORE PHOTOS**

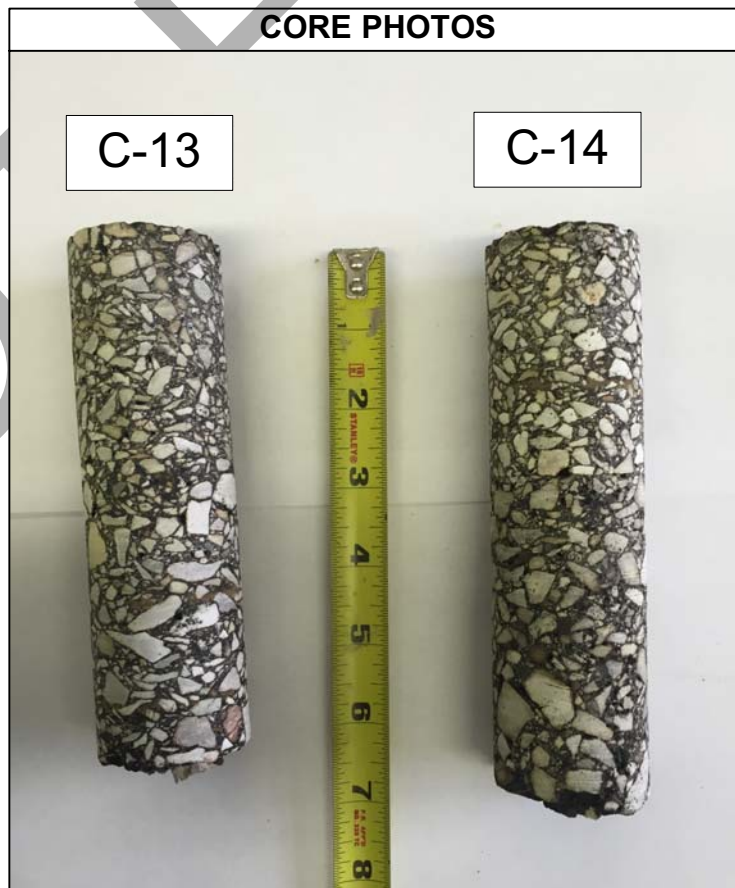

**2015 Village of Villa Park Road Improvements - Pavement Corings**

**West Division Street from Princeton Avenue to Ardmore Avenue (C-15)**

**CORE C-15  
20 West Division Street**

	Thickness (in)	Condition
Surface	2.00	Fair to Good
Binder	4.00	Fair to Good
<b>Total Pavement</b>	<b>6.00</b>	
Subbase	9.00	Crushed Limestone

Diagram



**CORE PHOTOS**



NOT

**2015 Village of Villa Park Road Improvements - Pavement Corings**

**Ellsworth Avenue from Armitage Avenue to 660 ft South (C-16 to C-17)**

<b>CORE C-16 824 Ellsworth Avenue</b>			Diagram
	Thickness (in)	Condition	
<b>Total Pavement (Concrete)</b>	8.00	Fair to Good	
Subbase	4.00	Crushed Limestone	

<b>CORE C-17 854 Ellsworth Avenue</b>			Diagram
	Thickness (in)	Condition	
<b>Total Pavement (Concrete)</b>	7.75	Fair to Good	
Subbase	7.00	Crushed Limestone	

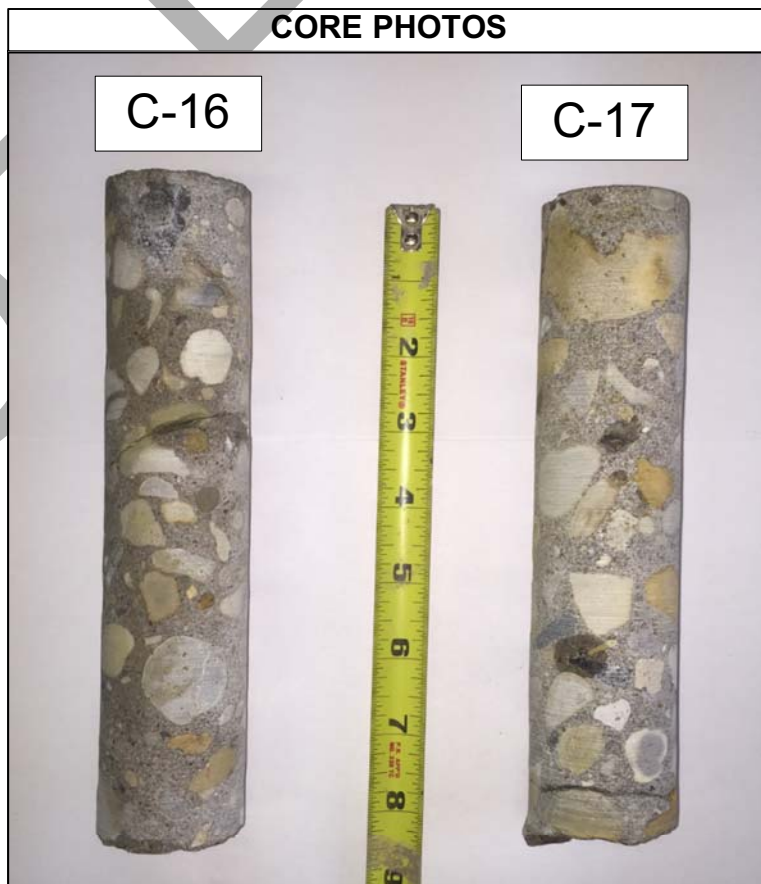

**2015 Village of Villa Park Road Improvements - Pavement Corings**

**Ellsworth Avenue from 660 ft South to Sidney Court (C-18 to C-19)**

<b>CORE C-18 904 Ellsworth Avenue</b>			Diagram
	Thickness (in)	Condition	
<b>Total Pavement</b>	7.75	Good	
Subbase	~ 22.25	Crushed Limestone	

<b>CORE C-19 932 Ellsworth Avenue</b>			Diagram
	Thickness (in)	Condition	
<b>Total Pavement (Concrete)</b>	7.75	Good	
Subbase	13.00	Crushed Limestone	

**CORE PHOTOS**

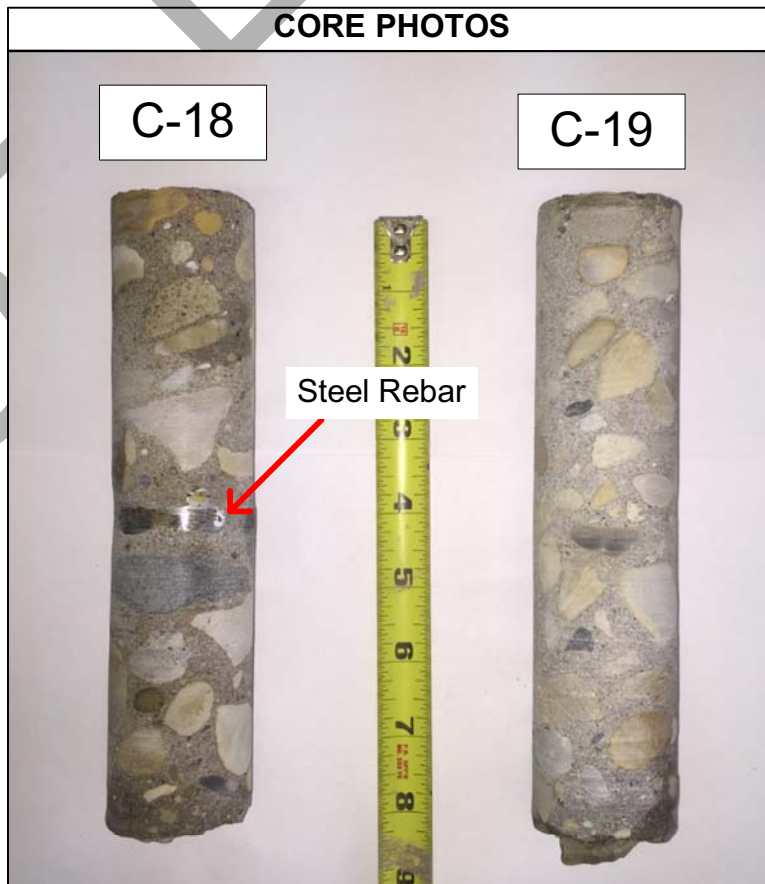

**2015 Village of Villa Park Road Improvements - Pavement Corings**

**Ellsworth Avenue from Sidney Court to Adele Court (C-20 to C-21)**

<b>CORE C-20 995 Ellsworth Avenue</b>			Diagram
	Thickness (in)	Condition	
<b>Total Pavement (Concrete)</b>	7.75	Fair to Good	
Subbase	15.25	Crushed Limestone	

<b>CORE C-21 1022 Ellsworth Avenue</b>			Diagram
	Thickness (in)	Condition	
<b>Total Pavement (Concrete)</b>	8.00	Good	
Subbase	4.00	Crushed Limestone	

**CORE PHOTOS**



**2015 Village of Villa Park Road Improvements - Pavement Corings**

**Ellsworth Avenue from Adele Court to 660 ft South (C-22 to C-23)**

<b>CORE C-22 875 Ellsworth Avenue</b>			Diagram
	Thickness (in)	Condition	
<b>Total Pavement (Concrete)</b>	8.00	Fair to Good	
Subbase	~ 22.00	Crushed Limestone	

<b>CORE C-23 865 Ellsworth Avenue</b>			Diagram
	Thickness (in)	Condition	
<b>Total Pavement (Concrete)</b>	7.75	Fair to Good	
Subbase	~ 22.25	Crushed Limestone	

**CORE PHOTOS**

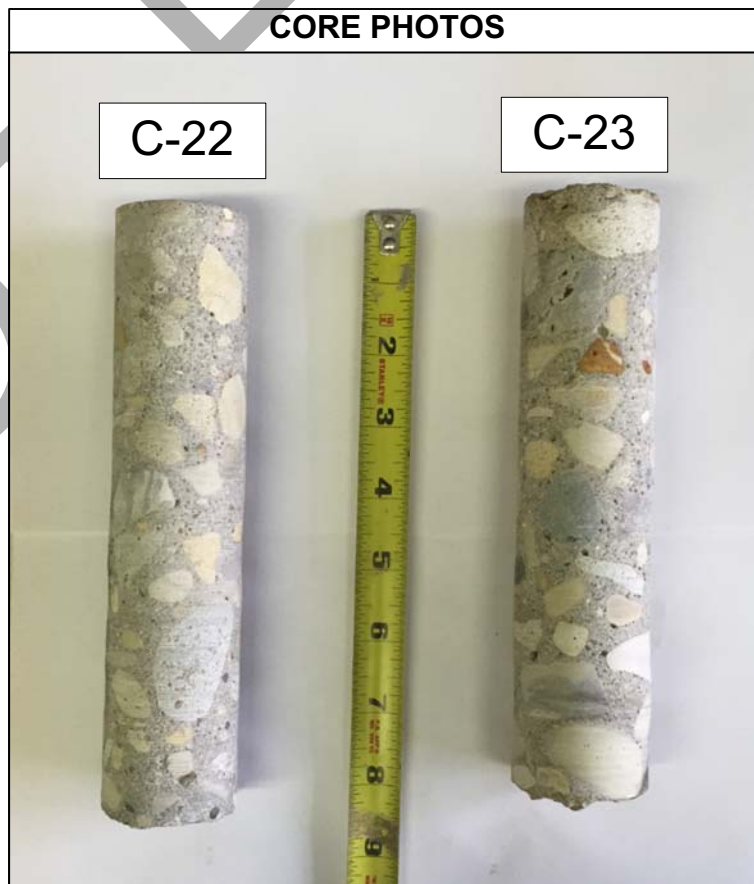

**2015 Village of Villa Park Road Improvements - Pavement Corings**

**Ellsworth Avenue from 660 ft South to North Avenue (C-24)**

CORE C-24 150 North Avenue			Diagram
	Thickness (in)	Condition	
Total Pavement (Concrete)	10.25	Fair	
Subbase	<b>**SEE BELOW**</b>	Crushed Limestone	

**\*\* The thickness of crushed limestone was not obtained due to boring refusal from the presence of steel rebar \*\***

**CORE PHOTOS**



**2015 Village of Villa Park Road Improvements - Pavement Corings**

**Grant Avenue from Washington Boulevard to the South End (C-25 to C-26)**

<b>CORE C-25 609 Grant Avenue</b>			Diagram
	Thickness (in)	Condition	
Surface	2.25	Poor	
Binder	0.00		
<b>Total Pavement</b>	<b>2.25</b>		
Subbase	9.75	Crushed Limestone	

<b>CORE C-26 630 Grant Avenue</b>			Diagram
	Thickness (in)	Condition	
Surface	0.00		
Binder	3.00	Poor	
<b>Total Pavement</b>	<b>3.00</b>		
Subbase	19.00	Crushed Limestone	

**CORE PHOTOS**

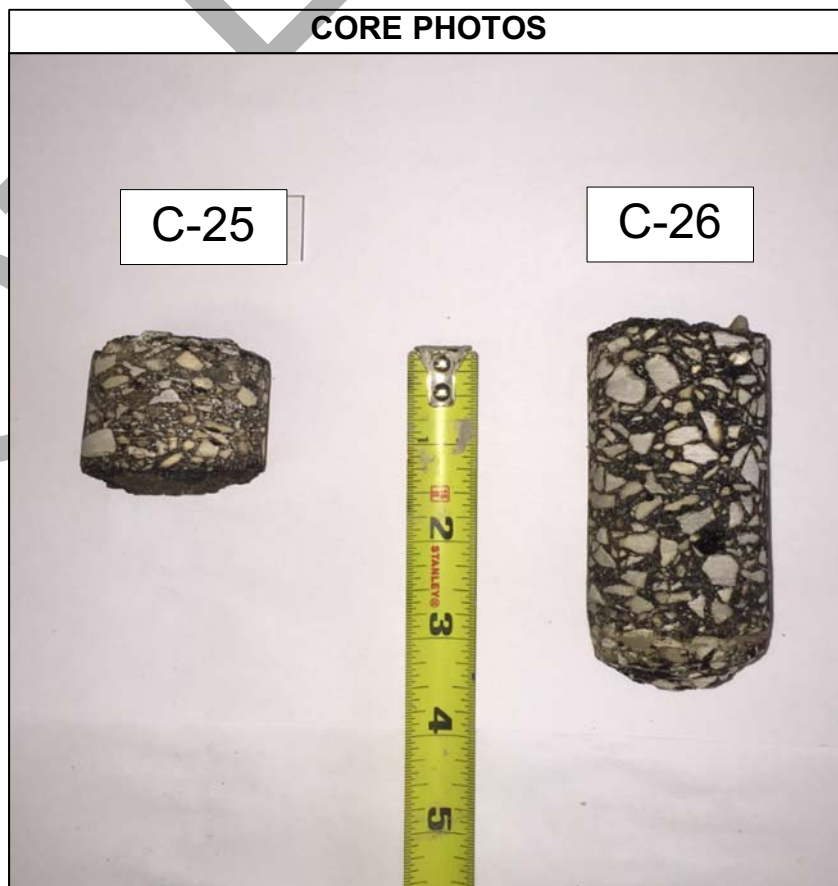

**2015 Village of Villa Park Road Improvements - Pavement Corings**

**Home Alley from Harvard Avenue to the Pavement Change (C-27 to C-29)**

<b>CORE C-27</b> <b>149 West St Charles Road (alley)</b>			Diagram
	Thickness (in)	Condition	
Surface	3.00	Poor	
Binder	2.25	Poor	
<b>Total Pavement</b>	<b>5.25</b>		
Subbase	7.75	Recycled Stone	

<b>CORE C-28</b> <b>125 West St Charles Road (alley)</b>			Diagram
	Thickness (in)	Condition	
Surface	2.25	Poor	
Binder	1.75	Poor	
<b>Total Pavement</b>	<b>4.00</b>		
Subbase	8.00	Recycled Stone	

<b>CORE C-29</b> <b>55-A West St Charles Road (alley)</b>			Diagram
	Thickness (in)	Condition	
Surface	0.00		
Binder	3.00	Poor	
<b>Total Pavement</b>	<b>3.00</b>		
Subbase	9.00	Recycled Stone	

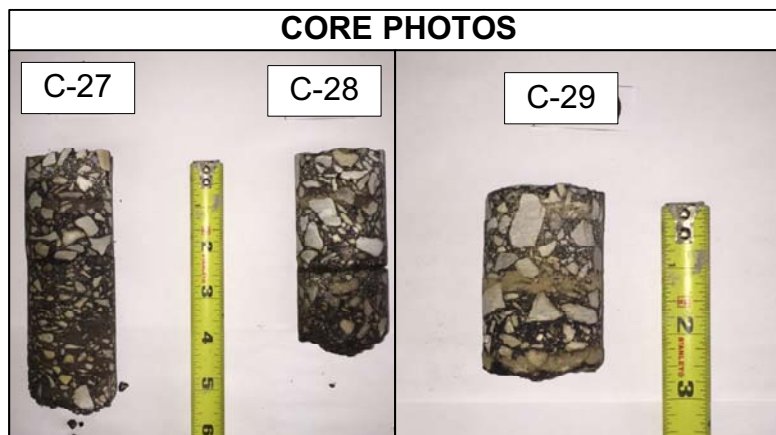

**2015 Village of Villa Park Road Improvements - Pavement Corings**

**Home Alley from the Pavement Change to Ardmore Avenue (C-30 to C-31)**

<b>CORE C-30</b> <b>28 Home Avenue (alley)</b>		
	Thickness (in)	Condition
Surface	1.75	Poor to Fair
Binder	3.00	Poor to Fair
<b>Total Pavement</b>	<b>4.75</b>	
Subbase	9.75	Recycled Stone

Diagram



<b>CORE C-31</b> <b>20 South Ardmore Avenue (alley)</b>		
	Thickness (in)	Condition
Surface	2.25	Fair
Binder	3.25	Fair
<b>Total Pavement</b>	<b>5.50</b>	
Subbase	15.50	Crushed Limestone

Diagram

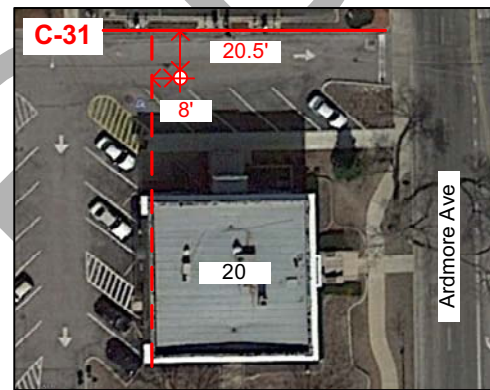

**CORE PHOTOS**

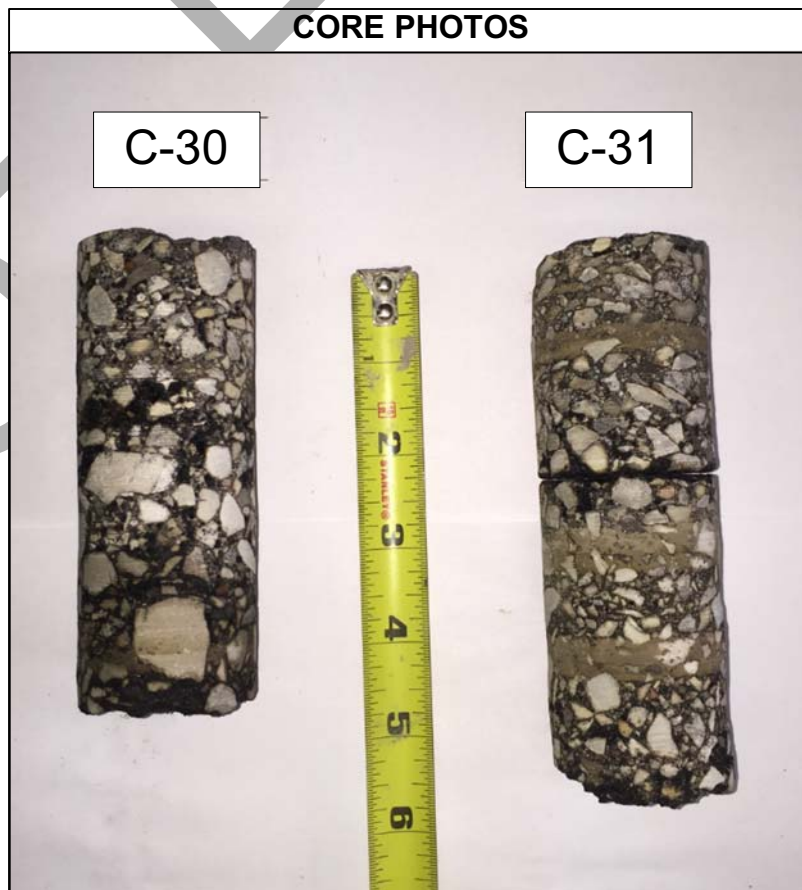

**2015 Village of Villa Park Road Improvements - Pavement Corings**

**East Sidney Court from Ellsworth Avenue to the East End (C-32 to C-33)**

<b>CORE C-32 995 Ellsworth Avenue</b>			Diagram
	Thickness (in)	Condition	
<b>Total Pavement (Concrete)</b>	8.50	Fair to Good	
Subbase	15.50	Crushed Limestone	

<b>CORE C-33 236 East Sidney Court</b>			Diagram
	Thickness (in)	Condition	
<b>Total Pavement (Concrete)</b>	8.00	Fair	
Subbase	~ 28.00	Crushed Limestone	

**CORE PHOTOS**



**2015 Village of Villa Park Road Improvements - Pavement Corings**

**North Yale Avenue from the North End to Division Street (C-34)**

CORE C-34 112 West Division Street		
	Thickness (in)	Condition
Surface	2.25	Fair to Good
Binder	1.00	Fair
<b>Total Pavement</b>	<b>3.25</b>	
Subbase	11.50	Crushed Limestone

Diagram

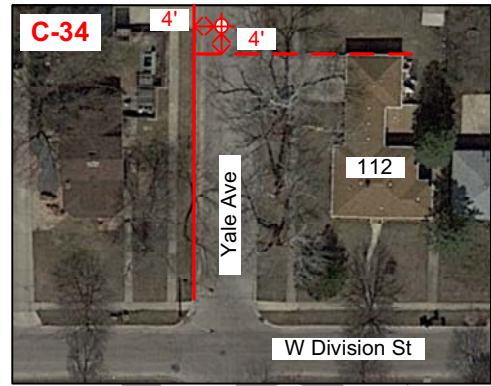

# **Report of Pavement Core Exploration**

**Biermann Second and Third  
Avenues**

**Villa Park, Illinois**

**Village of Villa Park**

NOT FOR BIDD

NOT FOR BID



TESTING SERVICE CORPORATION

*Corporate Office:*

360 S. Main Place, Carol Stream, IL 60188-2404  
630.462.2600 • Fax 630.653.2988

*Local Office:*

457 E. Gundersen Drive, Carol Stream, IL 60188-2492  
630.653.3920 • Fax 630.653.2726

Local Office  
March 6, 2015

Mr. Kevin L. Mantels  
Village of Villa Park  
20 South Ardmore Avenue  
Villa Park, IL 60181

Re: L-82,755  
Pavement Cores  
Biermann, Second and Third Avenues  
Villa Park, Illinois

Dear Mr. Mantels:

This report presents results of pavement cores taken along Biermann, Second and Third Avenues in Villa Park, Illinois. These geotechnical engineering services are being provided in accordance with TSC Proposal No. 54,018 dated December 17, 2014 and the attached General Conditions, incorporated herein by reference.

The project site consists of Biermann, Second and Third Avenues located in the northwest corner of Villa Park. They are situated just south of North Avenue (Illinois Route 64) and extend south all the way to West Terrace Street. The roadways were noted to be in fair to poor condition with isolated areas of spalling along with bituminous patches, as well as longitudinal and transverse joint cracks, corner cracks and meander cracks. These pavement failures may be due to poor drainage, frost action and/or weak subgrade. Current plans call for rehabilitation and/or reconstruction of the three residential streets.

### **Summary of Work Performed**

Work performed for this project included performing a total of thirty-two (32) pavement cores. The core locations were selected and marked on the pavement by TSC. Reference is made to the Core Location Plan included with this report. Once they were marked, JULIE (Joint Utility Locating for Excavators) was contacted so that the various underground utility lines could be cleared. Reference is made to the Core Location Plans attached.

The pavement cores were obtained using a 4" diameter core barrel with an impregnated diamond matrix bit. Granular base course materials were also obtained using a geo-probe at the core locations to determine their thicknesses, with split-spoon samples then taken of the upper subgrade to a depth of approximately 3 feet below the top of pavement. The core holes were immediately backfilled and patched to preclude possible hazards to the public.

The pavement cores and aggregate samples were examined by a construction materials technician in the laboratory. These detailed results are shown on the attached sheets titled "Pavement Core Results". Bituminous layers are listed individually, including their average thickness and condition comments. Total asphalt and base course thicknesses are also given, rounded to the nearest ¼" and 1", respectively.



Subgrade soil samples were examined in the laboratory to verify field descriptions and to classify them in accordance with the Unified Soil Classification System. Laboratory testing included water content determinations for all cohesive and intermediate (silt or loamy) soil types along with dry unit weight determinations on cohesive fill. An estimate of unconfined compressive strength was obtained for all cohesive soils using a calibrated pocket penetrometer. The soil descriptions at the core locations are summarized on the attached sheets titled "Subgrade Test Results". The depth of the samples are referenced to the top of the pavement (in feet).

**Pavement Core Results**

Results of the thirty-two (32) pavement cores are summarized in the following table, i.e. P.C. Concrete and Base Course total thicknesses given.

**SUMMARY OF CORE RESULTS**

Core No.	P.C. Concrete Thickness* (in)	Base Course Thickness** (in)
1	6½	30+
2	6½	2
3	5½	9
4	6½	22
5	6¼	30+
6	6¼	1
7	6¼	1
8	6	-
9	6½	30+
10	6¾	3
11	10	26+
12	5½	4
13	7	7
14	6½	8
15	6½	8
16	6¼	10
17	7	14
18	5¾	2



Core No.	P.C. Concrete Thickness* (in)	Base Course Thickness** (in)
19	6½	2
20	6¾	-
21	6¾	4
22	6¼	2
23	5¾	-
24	5¼	7 #
25	7	2
26	6¼	4
27	6½	-
28	6¾	1
29	7	10
30	6½	2
31	6¼	2
32	6¼	1

\* Total P.C. Concrete thicknesses rounded to the nearest ¼ inch.

\*\* Base Course thicknesses rounded to the nearest 1 inch.

# Pavement Core terminated within base course materials

Cores 1 - 32 were taken in order to determine an accurate thickness and composition of the pavement and base course materials. They typically revealed 5½ to 7 inches P.C. concrete with up to 10 inches at C-11. They usually were found overlying 1 to 10 inches crushed stone base course materials with 22 to 30+ inches at Cores 1, 4, 5, 9 and 11. Base course materials were apparently absent from Cores 8, 20, 23 and 27. The size of the crushed stone ranged ½" to 1" with fines. It was noted the crushed stone base course in Core 1 was layered with clay, and that the crushed stone base course extended to core completion depths in Cores 1, 5, 9 and 11. Core 24 was terminated within the granular base course materials approximately 12 inches below the top of pavement due to a rock obstruction. It should also noted that there was no steel observed in the P.C. concrete.

Silty clay fill was encountered beneath the granular section in Cores 2, 19 and 22 being in a soft to tough condition. The fill exhibited pocket penetrometer readings ranging from 0.5 to 1.5 tons per square foot (tsf). Moisture contents varied from 15 to 27 percent at dry unit weights on the order of 98 pounds per cubic foot (pcf).

Tough to very tough native silty clay soils otherwise predominated in the cores, extending to completion depths (3 feet deep). They had pocket penetrometer values typically ranging from 1.5 to 4.0 tsf at

moisture contents usually varying from 15 to 26 percent, and as high as 28 percent in Cores 13 and 19. Soft to stiff native silty clay soils were present in Cores 10, 12, 14, 21, 22, 25, 26, 27, 28, 29, 30 and 31 (11 total). They exhibited pocket penetrometer readings of 1.0 tsf or less at moisture contents generally varying from 15 to 26 percent, with moisture contents as high as 31 to 38 percent in Cores 10, 14, 22, 27 and 29 (5 total).

### **Analysis and Recommendations**

It is understood rehabilitation and/or reconstruction is planned for Biermann, Second and Third Avenues. Cores 1 - 32 typically revealed 5½ to 7 inches of P.C. concrete considered suitable for milling and resurfacing. As long as reflective cracking can be tolerated Biermann, Second and Third Avenues may be milled and resurfaced. It should be understood that milling and overlay is a temporary fix with a limited life span and will not have the same results as total pavement reconstruction.

However, in areas where the pavement is in poor condition the concrete pavement may be too deteriorated to save. It should be noted that the milling process may cause the concrete pavement to break apart. The exposed pavement section may get to the point where it becomes unsuitable for overlaying with removal and replacement of the P.C. concrete being required as part of pavement rehabilitation.

In order to reduce reflective cracking, repairs to the P.C. concrete should be preformed once milling operations have completed. These repairs may include full depth patching at the slab joints, full depth patching along the cracks at the edge of pavement, at the corners of the slab, and anywhere else where cracks are present. In some severe cases full slab replacement may be required where most of the slab has failed. A 4.75 mm Sand Mix layer may then be applied to further help reduce reflective cracking. It is recommended that a tack coat also be used to create a strong adhesive bond without slippage.

It should finally be understood that the existing subgrade soils at about half the core locations provide a marginal to deficient base for pavement support. They consisted of clay soils having relatively low unconfined compressive strengths (<1.5 tsf) and/or relatively high moisture contents (25-40 percent). These soils have the potential to pump and roll beneath the weight of existing traffic as well as the heavy construction equipment associated with milling and overlaying.

If the existing subgrade is exposed as part of pavement reconstruction it should be anticipated that the subgrade soils will in most cases have to be reduced in moisture content and recompacted in order to provide a stable subgrade prior to paving. Compaction to 95 percent of Modified Proctor density is recommended to create a stable base for proof-rolling and paving. If paving construction is performed when drying of surficial soils cannot be accomplished, removal of unstable subgrade and replacement with approximately 1 foot of granular materials may be required.

It is recommended that a nominal Illinois Bearing Ratio (IBR) value of 2.5 be used for the design of the new pavements. Use of this value assumes that any soft or unstable areas will be remediated, i.e. subgrade stabilized until passing a proof-roll. Base course materials for any widened areas should conform to IDOT gradation specification CA-6 and be compacted to 95 percent Modified Proctor density (ASTM D 1557) or 100 percent of the Standard Proctor (ASTM D 698) maximum density value.



Bituminous materials should conform to an approved IDOT Superpave mix design (N50 typical for residential streets), as well as Standard Specifications for Road and Bridge Construction, Sections 406 and 1032. They should be compacted to between 93 and 97 percent of their theoretical maximum density, as determined by the supplier.

**Closure**

The analyses and recommendations submitted in this report are based upon the data obtained from the thirty-two (32) pavement cores performed at the locations indicated on the Core Location Plans. This report does not reflect any variations which may occur between core locations, the nature and extent of which may not become evident until during the course of construction. If variations are then identified, recommendations contained in this report should be re-evaluated after performing on-site observations.

Please call if there are any questions in regard to this matter or if we may be of further service.

Respectfully submitted,

TESTING SERVICE CORPORATION

A handwritten signature in blue ink that reads "Erik A. Dunn".

Erik A. Dunn  
Engineering Intern

A handwritten signature in blue ink that reads "Timothy R. Peceniak".

Timothy R. Peceniak, P.E.  
Project Engineer  
Registered Professional Engineer  
Illinois No. 062-061269

EAD:TRP



## TESTING SERVICE CORPORATION

# GENERAL CONDITIONS

## Geotechnical and Construction Services

**1. PARTIES AND SCOPE OF WORK:** If Client is ordering the services on behalf of another, Client represents and warrants that Client is the duly authorized agent of said party for the purpose of ordering and directing said services, and in such case the term "Client" shall also include the principal for whom the services are being performed. Prices quoted and charged by TSC for its services are predicated on the conditions and the allocations of risks and obligations expressed in these General Conditions. Unless otherwise stated in writing, Client assumes sole responsibility for determining whether the quantity and the nature of the services ordered by Client are adequate and sufficient for Client's intended purpose. Unless otherwise expressly assumed in writing, TSC's services are provided exclusively for client. TSC shall have no duty or obligation other than those duties and obligations expressly set forth in this Agreement. TSC shall have no duty to any third party. Client shall communicate these General Conditions to each and every party to whom the Client transmits any report prepared by TSC. Ordering services from TSC shall constitute acceptance of TSC's proposal and these General Conditions.

**2. SCHEDULING OF SERVICES:** The services set forth in this Agreement will be accomplished in a timely and workmanlike manner. If TSC is required to delay any part of its services to accommodate the requests or requirements of Client, regulatory agencies, or third parties, or due to any cause beyond its reasonable control, Client agrees to pay such additional charges, if any, as may be applicable.

**3. ACCESS TO SITE:** TSC shall take reasonable measures and precautions to minimize damage to the site and any improvements located thereon as a result of its services or the use of its equipment; however, TSC has not included in its fee the cost of restoration of damage which may occur. If Client desires or requires TSC to restore the site to its former condition, TSC will, upon written request, perform such additional work as is necessary to do so and Client agrees to pay to TSC the cost thereof plus TSC's normal markup for overhead and profit.

**4. CLIENT'S DUTY TO NOTIFY ENGINEER:** Client represents and warrants that Client has advised TSC of any known or suspected hazardous materials, utility lines and underground structures at any site at which TSC is to perform services under this agreement.

**5. DISCOVERY OF POLLUTANTS:** TSC's services shall not include investigation for hazardous materials as defined by the Resource Conservation Recovery Act, 42 U.S.C. § 6901, et seq., as amended ("RCRA") or by any state or Federal statute or regulation. In the event that hazardous materials are discovered and identified by TSC, TSC's sole duty shall be to notify Client.

**6. MONITORING:** If this Agreement includes testing construction materials or observing any aspect of construction of improvements, Client's construction personnel will verify that the pad is properly located and sized to meet Client's projected building loads. Client shall cause all tests and inspections of the site, materials and work to be timely and properly performed in accordance with the plans, specifications, contract documents, and TSC's recommendations. No claims for loss, damage or injury shall be brought against TSC unless all tests and inspections have been so performed and unless TSC's recommendations have been followed.

TSC's services shall not include determining or implementing the means, methods, techniques or procedures of work done by the contractor(s) being monitored or whose work is being tested. TSC's services shall not include the authority to accept or reject work or to in any manner supervise the work of any contractor. TSC's services or failure to perform same shall not in any way operate or excuse any contractor from the performance of its work in accordance

with its contract. "Contractor" as used herein shall include subcontractors, suppliers, architects, engineers and construction managers.

Information obtained from borings, observations and analyses of sample materials shall be reported in formats considered appropriate by TSC unless directed otherwise by Client. Such information is considered evidence, but any inference or conclusion based thereon is, necessarily, an opinion also based on engineering judgment and shall not be construed as a representation of fact. Subsurface conditions may not be uniform throughout an entire site and ground water levels may fluctuate due to climatic and other variations. Construction materials may vary from the samples taken. Unless otherwise agreed in writing, the procedures employed by TSC are not designed to detect intentional concealment or misrepresentation of facts by others.

**7. DOCUMENTS AND SAMPLES:** Client is granted an exclusive license to use findings and reports prepared and issued by TSC and any sub-consultants pursuant to this Agreement for the purpose set forth in TSC's proposal provided that TSC has received payment in full for its services. TSC and, if applicable, its sub-consultant, retain all copyright and ownership interests in the reports, boring logs, maps, field data, field notes, laboratory test data and similar documents, and the ownership and freedom to use all data generated by it for any purpose. Unless otherwise agreed in writing, test specimens or samples will be disposed immediately upon completion of the test. All drilling samples or specimens will be disposed sixty (60) days after submission of TSC's report.

**8. TERMINATION:** TSC's obligation to provide services may be terminated by either party upon (7) seven days prior written notice. In the event of termination of TSC's services, TSC shall be compensated by Client for all services performed up to and including the termination date, including reimbursable expenses. The terms and conditions of these General Conditions shall survive the termination of TSC's obligation to provide services.

**9. PAYMENT:** Client shall be invoiced periodically for services performed. Client agrees to pay each invoice within thirty (30) days of its receipt. Client further agrees to pay interest on all amounts invoiced and not paid or objected to in writing for valid cause within sixty (60) days at the rate of twelve (12%) per annum (or the maximum interest rate permitted by applicable law, whichever is the lesser) until paid and TSC's costs of collection of such accounts, including court costs and reasonable attorney's fees.

**10. WARRANTY:** TSC's professional services will be performed, its findings obtained and its reports prepared in accordance with these General Conditions and with generally accepted principles and practices. In performing its professional services, TSC will use that degree of care and skill ordinarily exercised under similar circumstances by members of its profession. In performing physical work in pursuit of its professional services, TSC will use that degree of care and skill ordinarily used under similar circumstances. This warranty is in lieu of all other warranties or representations, either express or implied. Statements made in TSC reports are opinions based upon engineering judgment and are not to be construed as representations of fact.

Should TSC or any of its employees be found to have been negligent in performing professional services or to have made and breached any express or implied warranty, representation or contract, Client, all parties claiming through Client and all parties claiming to have in any way relied upon TSC's services or work agree that the maximum aggregate amount of damages for which TSC, its officers, employees and agents shall be liable is limited to \$50,000 or the total amount of the fee paid to TSC for its services performed with respect to the project, whichever amount is greater.

In the event Client is unwilling or unable to limit the damages for which TSC may be liable in accordance with the provisions set forth in the preceding paragraph, upon written request of Client received within five days of Client's acceptance of TSC's proposal together with payment of an additional fee in the amount of 5% of TSC's estimated cost for its services (to be adjusted to 5% of the amount actually billed by TSC for its services on the project at time of completion), the limit on damages shall be increased to \$500,000 or the amount of TSC's fee, whichever is the greater. This charge is not to be construed as being a charge for insurance of any type, but is increased consideration for the exposure to an award of greater damages.

**11. INDEMNITY:** Subject to the provisions set forth herein, TSC and Client hereby agree to indemnify and hold harmless each other and their respective shareholders, directors, officers, partners, employees, agents, subsidiaries and division (and each of their heirs, successors, and assigns) from any and all claims, demands, liabilities, suits, causes of action, judgments, costs and expenses, including reasonable attorneys' fees, arising, or allegedly arising, from personal injury, including death, property damage, including loss of use thereof, due in any manner to the negligence of either of them or their agents or employees or independent contractors. In the event both TSC and Client are found to be negligent or at fault, then any liability shall be apportioned between them pursuant to their pro rata share of negligence or fault. TSC and Client further agree that their liability to any third party shall, to the extent permitted by law, be several and not joint. The liability of TSC under this provision shall not exceed the policy limits of insurance carried by TSC. Neither TSC nor Client shall be bound under this indemnity agreement to liability determined in a proceeding in which it did not participate represented by its own independent counsel. The indemnities provided hereunder shall not terminate upon the termination or expiration of this Agreement, but may be modified to the extent of any waiver of subrogation agreed to by TSC and paid for by Client.

**12. SUBPOENAS:** TSC's employees shall not be retained as expert witnesses except by separate, written agreement. Client agrees to pay TSC pursuant to TSC's then current fee schedule for any TSC employee(s) subpoenaed by any party as an occurrence witness as a result of TSC's services.

**13. OTHER AGREEMENTS:** TSC shall not be bound by any provision or agreement (i) requiring or providing for arbitration of disputes or controversies arising out of this Agreement or its performance, (ii) wherein TSC waives any rights to a mechanics lien or surety bond claim; (iii) that conditions TSC's right to receive payment for its services upon payment to Client by any third party or (iv) that requires TSC to indemnify any party beyond its own negligence. These General Conditions are notice, where required, that TSC shall file a lien whenever necessary to collect past due amounts. This Agreement contains the entire understanding between the parties. Unless expressly accepted by TSC in writing prior to delivery of TSC's services, Client shall not add any conditions or impose conditions which are in conflict with those contained herein, and no such additional or conflicting terms shall be binding upon TSC. The unenforceability or invalidity of any provision or provisions shall not render any other provision or provisions unenforceable or invalid. This Agreement shall be construed and enforced in accordance with the laws of the State of Illinois. In the event of a dispute arising out of or relating to the performance of this Agreement, the breach thereof or TSC's services, the parties agree to try in good faith to settle the dispute by mediation under the Construction Industry Mediation Rules of the American Arbitration Association as a condition precedent to filing any demand for arbitration, or any petition or complaint with any court. Paragraph headings are for convenience only and shall not be construed as limiting the meaning of the provisions contained in these General Conditions.

## PAVEMENT CORE RESULTS

(Each component of pavement section listed from top down.)

### Biermann Avenue (Cores 1 - 8)

<b>Core 1:</b>	<u>6.6"</u>	<u>P.C. Concrete</u>	
	<b>6½"</b>	<b>Total P.C. Concrete Thickness</b>	
	3"	Crushed Stone Base Course	(1" Max with fines, Layered with clay)
	27+"	Crushed Stone Base Course	(1" Max with fines)
<b>Core 2:</b>	<u>6.4"</u>	<u>P.C. Concrete</u>	
	<b>6½"</b>	<b>Total P.C. Concrete Thickness</b>	
	2"	Crushed Stone Base Course	(1" Max with fines)
<b>Core 3:</b>	<u>5.4"</u>	<u>P.C. Concrete</u>	
	<b>5½"</b>	<b>Total P.C. Concrete Thickness</b>	
	9"	Crushed Stone Base Course	(1" Max with fines)
<b>Core 4:</b>	<u>6.6"</u>	<u>P.C. Concrete</u>	
	<b>6½"</b>	<b>Total P.C. Concrete Thickness</b>	
	22"	Crushed Stone Base Course	(1" Max with fines)
<b>Core 5:</b>	<u>6.3"</u>	<u>P.C. Concrete</u>	
	<b>6¼"</b>	<b>Total P.C. Concrete Thickness</b>	
	30+"	Crushed Stone Base Course	(1" Max with fines)
<b>Core 6:</b>	<u>6.3"</u>	<u>P.C. Concrete</u>	
	<b>6¼"</b>	<b>Total P.C. Concrete Thickness</b>	
	1"	Crushed Stone Base Course	(½" Max with fines)
<b>Core 7:</b>	<u>6.3"</u>	<u>P.C. Concrete</u>	
	<b>6¼"</b>	<b>Total P.C. Concrete Thickness</b>	
	1"	Crushed Stone Base Course	(½" Max with fines)
<b>Core 8:</b>	<u>6.1"</u>	<u>P.C. Concrete</u>	
	<b>6"</b>	<b>Total P.C. Concrete Thickness</b>	
		No Granular Base Course Present	

**Second Avenue (Cores 9 - 20)**

<b>Core 9:</b>	<u>6.4"</u> <b>6½"</b> 30+"	<u>P.C. Concrete</u> <b>Total P.C. Concrete Thickness</b> Crushed Stone Base Course	(1" Max with fines)
<b>Core 10:</b>	<u>6.7"</u> <b>6¾"</b> 3"	<u>P.C. Concrete</u> <b>Total P.C. Concrete Thickness</b> Crushed Stone Base Course	(¾" Max with fines)
<b>Core 11:</b>	<u>10.1"</u> <b>10"</b> 26+"	<u>P.C. Concrete</u> <b>Total P.C. Concrete Thickness</b> Crushed Stone Base Course	(¾" Max with fines)
<b>Core 12:</b>	<u>5.5"</u> <b>5½"</b> 4"	<u>P.C. Concrete</u> <b>Total P.C. Concrete Thickness</b> Crushed Stone Base Course	(1" Max with fines)
<b>Core 13:</b>	<u>7.1"</u> <b>7"</b> 7"	<u>P.C. Concrete</u> <b>Total P.C. Concrete Thickness</b> Crushed Stone Base Course	(½" Max with fines)
<b>Core 14:</b>	<u>6.4"</u> <b>6½"</b> 8"	<u>P.C. Concrete</u> <b>Total P.C. Concrete Thickness</b> Crushed Stone Base Course	(½" Max with fines)
<b>Core 15:</b>	<u>6.5"</u> <b>6½"</b> 8"	<u>P.C. Concrete</u> <b>Total P.C. Concrete Thickness</b> Crushed Stone Base Course	(½" Max with fines)
<b>Core 16:</b>	<u>6.3"</u> <b>6¼"</b> 10"	<u>P.C. Concrete</u> <b>Total P.C. Concrete Thickness</b> Crushed Stone Base Course	(½" Max with fines)
<b>Core 17:</b>	<u>6.9"</u> <b>7"</b> 14"	<u>P.C. Concrete</u> <b>Total P.C. Concrete Thickness</b> Crushed Stone Base Course	(1" Max with fines)





<b>Core 27:</b>	<u>6.4"</u> <b>6½"</b>	<u>P.C. Concrete</u> <b>Total P.C. Concrete Thickness</b> No Granular Base Course Present	
<b>Core 28:</b>	<u>6.8"</u> <b>6¾"</b> 1"	<u>P.C. Concrete</u> <b>Total P.C. Concrete Thickness</b> Crushed Stone Base Course	(½" Max with fines)
<b>Core 29:</b>	<u>6.9"</u> <b>7"</b> 10"	<u>P.C. Concrete</u> <b>Total P.C. Concrete Thickness</b> Crushed Stone Base Course	(½" Max with fines)
<b>Core 30:</b>	<u>6.6"</u> <b>6½"</b> 2"	<u>P.C. Concrete</u> <b>Total P.C. Concrete Thickness</b> Crushed Stone Base Course	(¾" Max with fines)
<b>Core 31:</b>	<u>6.2"</u> <b>6¼"</b> 2"	<u>P.C. Concrete</u> <b>Total P.C. Concrete Thickness</b> Crushed Stone Base Course	(½" Max with fines)
<b>Core 32:</b>	<u>6.2"</u> <b>6¼"</b> 1"	<u>P.C. Concrete</u> <b>Total P.C. Concrete Thickness</b> Crushed Stone Base Course	(¾" Max with fines)



# Subgrade Test Results

## TESTING SERVICE CORPORATION

457 EAST GUNDERSEN DR. · CAROL STREAM, ILLINOIS 60188-2492 · FAX: (630) 653-2726 · TEL: (630) 653-3920

Client: **Village of Villa Park**  
**20 South Ardmore Avenue**  
**Villa Park, IL 60181**

Date Tested	03/06/15
Job Number	L-82,755
Page Number	1 of 3

Project: **Pavement Cores**  
**Biermann, Second & Third Avenues**  
**Villa Park, IL**

Test Data					
Location	Depth	Moisture (%)	Qp (tsf)	γ Dry (pcf)	Soil Description
Core 1 Biermann Avenue	0.5' - 0.8'	17.2	---	---	Fill - Crushed stone (layered with clay)
	0.8' - 3.0'	5.6	---	---	Fill - Crushed stone
Core 2 Biermann Avenue	0.7' - 2.3'	26.5	1.5	98	Fill - Black brown and gray silty CLAY, little sand, trace gravel, trace organic, very moist (CL)
	2.3' - 3.0'	19.9	4.0	---	Brown and gray silty CLAY, little sand, trace gravel, moist (CL)
Core 3 Biermann Avenue	1.2' - 3.0'	21.1	3.0	107	Brown and gray silty CLAY, little sand, trace gravel, moist (CL)
Core 4 Biermann Avenue	2.4' - 3.0'	25.6	2.5	100	Black silty CLAY, little sand, trace gravel, trace organic, moist (CL-CH)
Core 5 Biermann Avenue	0.5' - 3.0'	---	---	---	Fill - Crushed Stone
Core 6 Biermann Avenue	0.6' - 3.0'	21.3	2.75	107	Brown and gray silty CLAY, little sand, trace gravel, moist (CL-ML)
Core 7 Biermann Avenue	0.6' - 3.0'	14.7	2.75	120	Brown and gray silty CLAY, little sand, trace gravel, moist (CL)
Core 8 Biermann Avenue	0.5' - 3.0'	19.4	2.75	111	Brown and gray silty CLAY, little sand, trace gravel, moist (CL)

Depth = Feet below top of pavement

Qp = Unconfined compressive strength in tons per square foot based on readings with a calibrated pocket penetrometer

### Comments

Subgrade samples taken to approximately 3 feet below top of pavement.

Field Technician(s)	Lab Technician	Reviewed By
J.J.M.	L.L./K.R./M.Q.	E.A.D.

Test Data					
Location	Depth	Moisture (%)	Qp (tsf)	$\gamma$ Dry (pcf)	Soil Description
Core 9 Second Avenue	0.5' - 3.0'	---	---	---	Fill - Crushed Stone
Core 10 Second Avenue	0.8' - 3.0'	31.8	0.5	91	Brown and gray silty CLAY, little sand, trace gravel, very moist (CL)
Core 11 Second Avenue	0.8' - 3.0'	---	---	---	Fill - Crushed Stone
Core 12 Second Avenue	0.8' - 3.0'	20.0	1.0	109	Brown and gray silty CLAY, little sand, trace gravel, very moist (CL)
Core 13 Second Avenue	1.2' - 2.3'	28.0	1.5	94	Brown gray and black silty CLAY, little sand, trace gravel, trace organic, very moist (CL)
	2.3' - 3.0'	23.3	2.0	100	Brown and gray silty CLAY, little sand, trace gravel, moist (CL)
Core 14 Second Avenue	1.2' - 3.0'	31.6	1.0	91	Brown gray and black silty CLAY, little sand, trace gravel, trace organic, very moist (CL)
Core 15 Second Avenue	1.2' - 3.0'	17.9	1.5	109	Brown and gray silty CLAY, little sand and gravel, very moist (CL)
Core 16 Second Avenue	1.4' - 3.0'	18.6	2.0	112	Brown and gray silty CLAY, little sand and gravel, moist (CL)
Core 17 Second Avenue	1.8' - 3.0'	22.3	2.0	105	Brown and gray silty CLAY, little sand, trace gravel, moist (CL)
Core 18 Second Avenue	0.6' - 3.0'	22.3	1.75	105	Brown gray and black silty CLAY, little sand, trace gravel, moist (CL)
Core 19 Second Avenue	0.7' - 2.0'	26.4	0.5	98	Fill - Black silty CLAY, little sand, trace gravel, trace organic, very moist (CL-CH) [Frost Cracks]
	2.0' - 3.0'	28.8	1.75	92	Black clayey silty CLAY, little sand, trace gravel, trace organic, moist (CL-CH)
Core 20 Second Avenue	0.6' - 3.0'	21.6	2.5	106	Dark Brown and gray silty CLAY, little sand, trace gravel, very moist (CL) [Frost Cracks]
Core 21 Third Avenue	0.9' - 3.0'	16.9	0.5	---	Black silty CLAY, little sand, trace gravel, very moist (CL-CH)
Core 22 Third Avenue	0.7' - 1.5'	14.9	0.5	---	Fill - Dark brown silty CLAY, little sand and gravel, very moist (CL)
	1.5' - 3.0'	32.2	0.25	82	Black silty CLAY, little sand, trace gravel, trace organic, very moist (CL-CH)
Depth = Feet below top of pavement					
Qp = Unconfined compressive strength in tons per square foot based on readings with a calibrated pocket penetrometer					
Comments					
Subgrade samples taken to approximately 3 feet below top of pavement.					
Field Technician(s)		Lab Technician		Reviewed By	
J.J.M.		L.L./K.R./M.Q.		E.A.D.	

Test Data					
Location	Depth	Moisture (%)	Qp (tsf)	$\gamma$ Dry (pcf)	Soil Description
Core 23 Third Avenue	0.5' - 3.0'	19.3	3.0	110	Brown and gray silty CLAY, little sand, trace gravel, moist (CL)
Core 24 Third Avenue	---	---	---	---	---
Core 25 Third Avenue	0.7' - 3.0'	15.2	0.5	---	Brown and gray silty CLAY, little sand and gravel, very moist (CL)
Core 26 Third Avenue	0.9' - 3.0'	21.3	0.5	106	Brown and gray silty CLAY, little sand, trace gravel, very moist (CL)
Core 27 Third Avenue	0.5' - 1.8'	32.7	0.5	---	Black silty CLAY, little sand, trace gravel, trace organic, very moist (CL)
	1.8' - 3.0'	25.1	2.0	100	Brown and gray silty CLAY, little sand, trace gravel, moist (CL)
Core 28 Third Avenue	0.6' - 3.0'	25.8	0.75	93	Brown and gray silty CLAY, little sand, trace gravel, very moist (CL)
Core 29 Third Avenue	1.4' - 2.3'	37.7	---	---	Black silty CLAY, little sand, trace gravel, very moist (CL)
	2.3' - 3.0'	29.4	1.75	94	Brown and gray silty CLAY, little sand, trace gravel, moist (CL)
Core 30 Third Avenue	0.7' - 3.0'	20.8	0.75	106	Brown and gray silty CLAY, little sand, trace gravel, very moist (CL)
Core 31 Third Avenue	0.7' - 3.0'	24.7	0.5	98	Brown and gray silty CLAY, little sand, trace gravel, very moist (CL)
Core 32 Third Avenue	0.6' - 3.0'	25.0	1.75	97	Brown and gray silty CLAY, little sand, trace gravel, moist (CL)
Depth = Feet below top of pavement					
Qp = Unconfined compressive strength in tons per square foot based on readings with a calibrated pocket penetrometer					
Comments					
Subgrade samples taken to approximately 3 feet below top of pavement.					
Field Technician(s)		Lab Technician		Reviewed By	
J.J.M.		L.L./K.R./M.Q.		E.A.D.	



**BORING LOCATION PLAN  
BIERMAN, SECOND & THIRD STREETS  
VILLA PARK, ILLINOIS**



TESTING SERVICE CORPORATION  
457 EAST GUNDERSEN DRIVE  
CAROL STREAM, ILLINOIS 60188

DRAWN BY: EAD  
CHECKED BY: EAD  
JOB NO. : L-82,755  
DATE: 01-13-15

PAGE NO.  
1 OF 2



**BORING LOCATION PLAN  
BIERMAN, SECOND & THIRD STREETS  
VILLA PARK, ILLINOIS**



TESTING SERVICE CORPORATION  
457 EAST GUNDERSEN DRIVE  
CAROL STREAM, ILLINOIS 60188

DRAWN BY: EAD  
CHECKED BY: EAD  
JOB NO. : L-82,755  
DATE: 01-13-15

PAGE NO.  
2 OF 2

NOT FOR BID



office: 1-847-870-0544  
fax: 1-847-870-0661  
www.soilandmaterialconsultants.com  
us@soilandmaterialconsultants.com

January 30, 2015  
File No. 21873

Mr. Kevin Mantels  
Village of Villa Park  
20 South Ardmore Avenue  
Villa Park, IL 60181

Re: Pavement Investigation  
Geotechnical Year 1 – Group 2  
Villa Park, Illinois

Dear Mr. Mantels:

We are submitting our report for the pavement investigation completed on various streets for the Geotechnical Year 1 - Group 2 Road Program located in the Village of Villa Park, Illinois.

The investigation was requested to determine existing pavement sections and subgrade soil support conditions. The information is intended to assist in planning, design and construction of the proposed road program.

#### SCOPE OF THE INVESTIGATION

The field investigation included a total of 32 test locations as shown on the enclosed sketches. The pavement section was cored to determine material types and thicknesses. The supporting soils were visually and texturally classified in the field to depths of 7.0 feet. Soil samples were obtained using a split barrel sampler advanced utilizing an automatic SPT hammer.

Pavement materials and soil samples obtained during the field investigation were returned to our laboratory for review and testing. Soil testing included determination of moisture content. Cohesive soils obtained by split barrel sampling were further tested to determine dry unit weight and unconfined compressive strength. The results of all field and laboratory testing are included in summary with this report.

#### RESULTS

The pavement cores determined the existing pavement section at the selected locations. Our findings are presented on the enclosed logs and are summarized as follows:

8 WEST COLLEGE DRIVE • ARLINGTON HEIGHTS, IL 60004

SOIL BORINGS • SITE INVESTIGATIONS • PAVEMENT INVESTIGATIONS • GEOTECHNICAL ENGINEERING  
TESTING OF • SOIL • ASPHALT • CONCRETE • MORTAR • STEEL

Location	HMA Surf. (in.)	HMA Bind. (in.)	Granular Base (in.)	Emulsified Soil & Agg. Mix (in.)	Total HMA (in.)	Total Pvmnt. (in.)
<b>Armitage Avenue – Harvard Drive to Ardmore Avenue</b>						
C/B-1	5.00		8.50		5.00	13.50
C/B-2	4.00**		4.50	5.75	4.00	14.25
C/B-3	2.50**	4.00	4.50		6.50	11.00
C/B-4	7.75**			3.75	7.75	11.50
C/B-5	5.25**			4.75	5.25	10.00

Location	Concrete (in.)	Granular Base (in.)	Total Pavement (in.)
<b>Armitage Avenue – Ellsworth Avenue to Villa Avenue</b>			
C/B-6	8.00	3.50	11.50
C/B-7	7.50	6.25	13.75
C/B-8	8.50	15.50	24.00

Location	HMA Surf. (in.)	HMA Bind. (in.)	Granular Base (in.)	Emulsified Soil & Agg. Mix (in.)	Total HMA (in.)	Total Pvmnt. (in.)
<b>W. Belden Avenue</b>						
C/B-9		2.00	5.00		2.00	7.00
C/B-10	0.75	1.50	9.50		2.25	11.75
C/B-11		3.50		4.00	3.50	7.50
C/B-12		3.75	6.50	4.00	3.75	14.25
C/B-13		3.75	4.75		3.75	8.50
<b>W. Sidney Avenue</b>						
C/B-14		2.75	10.75		2.75	13.50
C/B-15		2.50	57.50		2.50	60.00
C/B-16		1.75	21.25		1.75	23.00

Location	HMA Surf. (in.)	HMA Bind. (in.)	Granular Base (in.)	Bituminous Treated Agg. (in.)	Total HMA (in.)	Total Pvmnt. (in.)
<b>Yale Avenue</b>						
C/B-17	2.00	2.00	6.50	3.00	4.00	13.50
C/B-18	1.75	1.25*	3.25	2.75	3.00	9.00
C/B-19	1.75	2.00	2.00	3.75*	3.75	9.50
C/B-20	2.25		4.75	5.00	2.25	12.00
C/B-21	2.00		3.25	9.50*	2.00	14.75
C/B-22	2.25		5.25	3.50	2.25	11.00
C/B-23	2.00	1.75	6.75		3.75	10.50
C/B-24	2.00		4.00	6.00	2.00	12.00

\*Failures noted.

\*\*Petromat was noted beneath the most recent overlay.  
 Please refer to the core logs for more detailed information

Location	HMA Surf. (in.)	HMA Bind. (in.)	Granular Base (in.)	Emulsified Soil & Agg. Mix (in.)	Total HMA (in.)	Total Pvmnt. (in.)
<b><u>Princeton Avenue</u></b>						
C/B-25		4.00	2.50		4.00	6.50
C/B-26		3.25	3.00		3.25	6.25
C/B-27	1.25	2.00	32.75		3.25	36.00
C/B-28	2.25	3.50	4.25		5.75	10.00
C/B-29	1.75		82.25		1.75	84.00
<b><u>Ardmore Avenue</u></b>						
C/B-30	2.25**	3.00	4.75		5.25	10.00
C/B 31	7.50**			1.75	7.50	9.25
C/B 32	6.00**			5.25	6.00	11.25

\*Failures noted.

\*\*Petromat was noted beneath the most recent overlay.  
 Please refer to the core logs for more detailed information

**EXISTING CONDITIONS**

**Armitage Avenue**

Pavement cores and borings C/B-1 to C/B-5 were performed on Armitage Avenue between North Harvard Avenue and Ardmore Avenue. Visual examination of the pavement reveals areas with distress and failures but was generally in fair condition. Alligatoring, cold joint cracking, and meandering cracks were observed. Patching of previous distressed areas was also noted.

The pavement cores show the existing pavement sections at these locations include 4.0 inches to 7.75 inches of bituminous concrete over 4.5 inches to 8.5 inches of granular base and/or 3.75 inches to 5.75 inches of emulsified soil and aggregate mix. Petromat was noted at all locations except C/B-1. The total pavement section is found to range in thickness from 10.0 inches to 14.25 inches.

Directly beneath the pavement is the presence of topsoil which extended to depths of 2.0 to 3.0 feet. Cohesive soils were encountered underlying the topsoil at these locations and are classified as soft to hard clay/silt mixtures with lesser portions of sand and gravel. Cobbles and boulders may be present within the soil at any elevation, although none were encountered while drilling.

Locations C/B-6 to C/B-8 were performed on Armitage Avenue between Ellsworth Avenue and Villa Avenue. The existing concrete pavement revealed areas of distress and failures but was generally in fair condition. Bituminous concrete patches in previously distressed areas was noted.

The pavement cores show the existing pavement sections at these locations include 7.5 inches to 8.5 inches of concrete over 3.5 inches to 15.5 inches of granular base. The total pavement section is found to range in thickness from 11.5 inches to 24.0 inches.

Cohesive soils were encountered beneath the pavement materials at these locations. These are classified as very tough to hard clay/silt mixtures with lesser portions of sand and gravel. Cobbles and boulders may be present within the soil at any elevation, although none were encountered while drilling.

#### W. Belden Avenue

Locations C/B-9 through C/B-13 were performed on W. Belden Avenue from the west end to Ardmore Avenue. Visual examination of the pavement reveals areas with significant distress and was in a poor to extremely poor condition. Alligating, cold joint cracking, meandering cracks, raveling, and settlement were observed. Patching of previously distressed areas west of Yale Avenue was noted.

The pavement cores show the existing pavement sections at these locations include 2.0 inches to 3.75 inches of bituminous concrete over 4.75 inches to 9.5 inches of granular base and/or 4.0 inches of emulsified soil and aggregate mix. The total pavement section is found to range in thickness from 7.0 inches to 14.25 inches.

High moisture content topsoil was present directly beneath the pavement and extended to depths of 1.0 to 2.5 feet. Cohesive soils were encountered underlying the topsoil and are classified as stiff to hard clay/silt mixtures with lesser portions of sand and gravel. Cobbles and boulders may be present within the soil at any elevation, although none were encountered while drilling.

#### Sidney Avenue

Pavement cores and borings C/B-14 through C/B-16 were drilled to the scheduled depth of 7.0 feet. Boring C/B-14 was extended to a depth of 10.0 feet due to the presence of underlying organic silt. Visual examination of the pavement reveals areas with distress and was generally in fair to poor condition. Cold joint cracks, meandering cracking, and settlement were observed. Patching of previously distressed areas was also noted.

The pavement cores show the existing pavement sections at these locations include 1.75 inches to 2.75 inches of bituminous concrete over 10.75 inches to 57.5 inches of granular base. The total pavement section is found to range in thickness from 13.5 inches to 60.0 inches. The deep granular base at location C/B-15 is likely due to the presence of a utility trench.

Buried topsoil was present directly underlying the pavement at locations C/B-14 and C/B-16. The topsoil was found extending to depths of 3.5 to 5.5 feet. Cohesive soils were also encountered and are classified as soft to very tough clay/silt mixtures with lesser amounts of sand and gravel.

A deposit with significant high moisture content and low-strength organic clay and silt was encountered at C/B-14. These soils are highly compressible due to their high moisture contents and are likely present in other areas of the site but were not discovered within the scope of this investigation.

### Yale Avenue

Locations C/B-17 to C/B-24 were performed on Yale Avenue between West Armitage Avenue and Wildfire Drive. Visual examination of the pavement reveals areas with meandering cracks and settlement along the pavement edges. The roadway was generally in fair condition.

The pavement cores show the existing pavement sections at these locations include 2.0 inches to 4.0 inches of bituminous concrete over 2.75 inches to 9.5 inches of bituminous treated aggregate and 4.0 inches to 12.0 inches of granular base with the exception of C/B-23 which only contains granular base. The total pavement section is found to range in thickness from 9.0 inches to 15.75 inches.

Fill soils were encountered directly underlying the pavement materials at locations C/B-21 and C/B-22. Composition of the fill includes the presence of clay/silt mixtures extending to depths of 1.5 feet to 2.0 feet at these locations. The limits of fill placement were not determined within the scope of this investigation.

Buried topsoil was noted beneath the pavement material and/or fill soils at locations C/B-17 through C/B-23. The topsoil extended to depths of 2.0 feet to 4.0 feet.

Underlying natural soil conditions consist of cohesive soils. These are classified as soft to hard clay/silt mixtures with lesser portions of sand and gravel. Portions of these soils are sometimes high in moisture content with values in excess of 30% determined.

Non-cohesive soils were also encountered as indicated at the bottom of boring C/B-24. These include medium dense sand/silt mixtures. Cobbles and boulders may be present within the site soils at any elevation, although none were encountered while drilling.

Significant deposits of high moisture content and low-strength organic silts and clays are indicated at borings C/B-21 and C/B-22. These conditions are likely present in other areas of the site but were not discovered within the scope of this investigation.

### Princeton Avenue

Pavement cores and borings C/B-25 to C/B-29 were performed on Princeton Avenue south of West Armitage Avenue. Visual examination of the pavement reveals areas with significant distress between Armitage Avenue and West Belden Avenue. These include cold joint cracking, meandering cracks, alligating, material raveling, potholes, and settlement. The poor surface condition prevents effective water run-off.

C/B-27 and C/B-28 were located between Belden Avenue and the south end of Princeton with location C/B-29 on the section of Princeton Avenue north of Wildfire Drive. Visual examination of the pavement reveals areas of some distress. These include cold joint cracking, meandering cracks, alligating, potholes, and settlement. Patching of previously distressed areas was noted. The poor surface condition prevents effective water run-off in some areas.

The pavement cores show the existing pavement sections at these locations include 1.75 inches to 5.75 inches of bituminous concrete over 2.75 inches to 82.25 inches of granular base. The total pavement section is found to range in thickness from 6.25 inches to 84.0 inches. The

deep granular base indicated at locations C/B-27 and C/B-29 is likely due to the presence of utility trenches.

Topsoil was present directly beneath the pavement materials at locations C/B-25 through C/B-28 and was found extending to depths of 2.0 to 4.5 feet. Cohesive soils were encountered underlying the topsoil at these locations. These are classified as very soft to hard clay/silt mixtures with lesser portions of sand and gravel. Cobbles and boulders may be present within the site soils at any elevation, although none were encountered while drilling.

A significant deposit of high moisture content and low-strength organic silt is indicated at boring C/B-27. These conditions are likely present in other areas of the site but were not discovered within the scope of this investigation.

#### Ardmore Avenue

Locations C/B-30 to C/B-32 were performed on Ardmore Avenue between East Armitage Avenue and West Belden Avenue. Visual examination of the pavement reveals areas of some distress. These include edge cracking, meandering cracks, and alligating.

The pavement cores show the existing pavement sections at these locations include 5.25 inches to 7.5 inches of bituminous concrete over 4.5 inches of granular base or 1.75 inches to 5.25 inches of emulsified soil and aggregate mix. Petromat was noted beneath the most recent surface overlay at each of the locations. The total pavement section ranges in thickness from 9.25 inches to 11.25 inches.

Topsoil was present directly beneath the pavement at each of the locations and extended to depths of 1.5 to 2.0 feet. Cohesive soils, classified as tough to hard clay/silt mixtures with lesser portions of sand and gravel are present beneath the topsoil. A layer of loose silt/clay was also encountered as indicated at location C/B-32. Cobbles and boulders may be present within the soil at any elevation, although none were encountered while drilling.

#### DISCUSSION

##### Grind and Overlay

Some of the streets included in this investigation could be considered for a grind and overlay form of pavement rehabilitation. Generally this would include milling of the existing bituminous surface as needed for overlaying. A thin mill or thicker overlay could be considered if the profile of the road allows for the surface of the pavement to be elevated. Deeper milling may be needed in areas where failures were noted in the original bituminous materials. Surface areas with extensive pavement deterioration will likely require full depth patching with either bituminous concrete binder, portland cement concrete (on Armitage east of Ellsworth), or a combination of crushed aggregate (CA06) and binder. A leveling binder should then be placed as needed. The use of a reflective crack control fabric can also be considered. The new design thickness of HMA surface overlay would then be placed.

Some streets that could be considered for a typical grind and overlay procedure are Armitage Avenue, Yale Avenue, and Ardmore Avenue.

### Partial Reconstruction

Some of the other streets included in the investigation could be considered for a partial reconstruction form of rehabilitation. This would include the removal of all the existing bituminous materials. The underlying original granular base would then be re-graded, compacted and proof rolled. Areas that are found to be unstable would then be removed and replaced with a minimum of 12.0 inches of crushed aggregate, CA06, over a woven geotextile fabric. Any new aggregate base, if needed, would then be placed and compacted. A new bituminous pavement section that includes a minimum of 2.25 inches of HMA binder and 1.5 inches of HMA surface would then be placed.

Some streets that could be considered for partial reconstruction are as follows: West Belden Avenue west of Yale Avenue, Sidney Avenue, Princeton Avenue between Belden Avenue and the south end, and Princeton Avenue north of Wildfire Drive to the north end.

### Total Reconstruction

Total reconstruction of some streets will be necessary due to the extensive amount of pavement deterioration that has occurred combined with the amount of patching that may be needed. The complete reconstruction of the pavement would include the removal of all the existing pavement materials and high organic topsoil. The presence of buried topsoil extending to approximate depths of 1.5 feet to 2.5 feet should be considered in the design. The subgrade would then be excavated to the design elevation, compacted and proof rolled. Any areas of unstable soils will most likely require removal and replacement with large crushed aggregate, possibly in conjunction with the use of an appropriate geotextile fabric. The new aggregate base would then be placed and compacted followed by the placement of the designed thickness of bituminous concrete binder and bituminous concrete surface courses.

Streets that should be considered for a total reconstruction are West Belden Avenue between Yale Avenue and Ardmore Avenue and Princeton Avenue between Armitage Avenue and Belden Avenue. Any of the other streets could also be considered for a total reconstruction but may not be economically feasible.

### CONCLUSION

This report has been prepared to assist in initial determination of existing pavement sections and supporting soil conditions. Locally varying conditions may be present between test locations.

Any questions concerning the information presented in this report should be directed to our office.

Very truly yours,

SOIL AND MATERIAL CONSULTANTS, INC.



Reid T. Steinbach, E.I.T  
Project Engineer

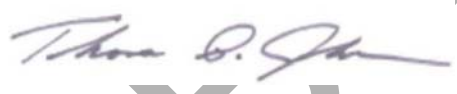

Thomas P. Johnson, P.E.  
President

Enc.RTS/TPJ

NOT FOR REVIEW

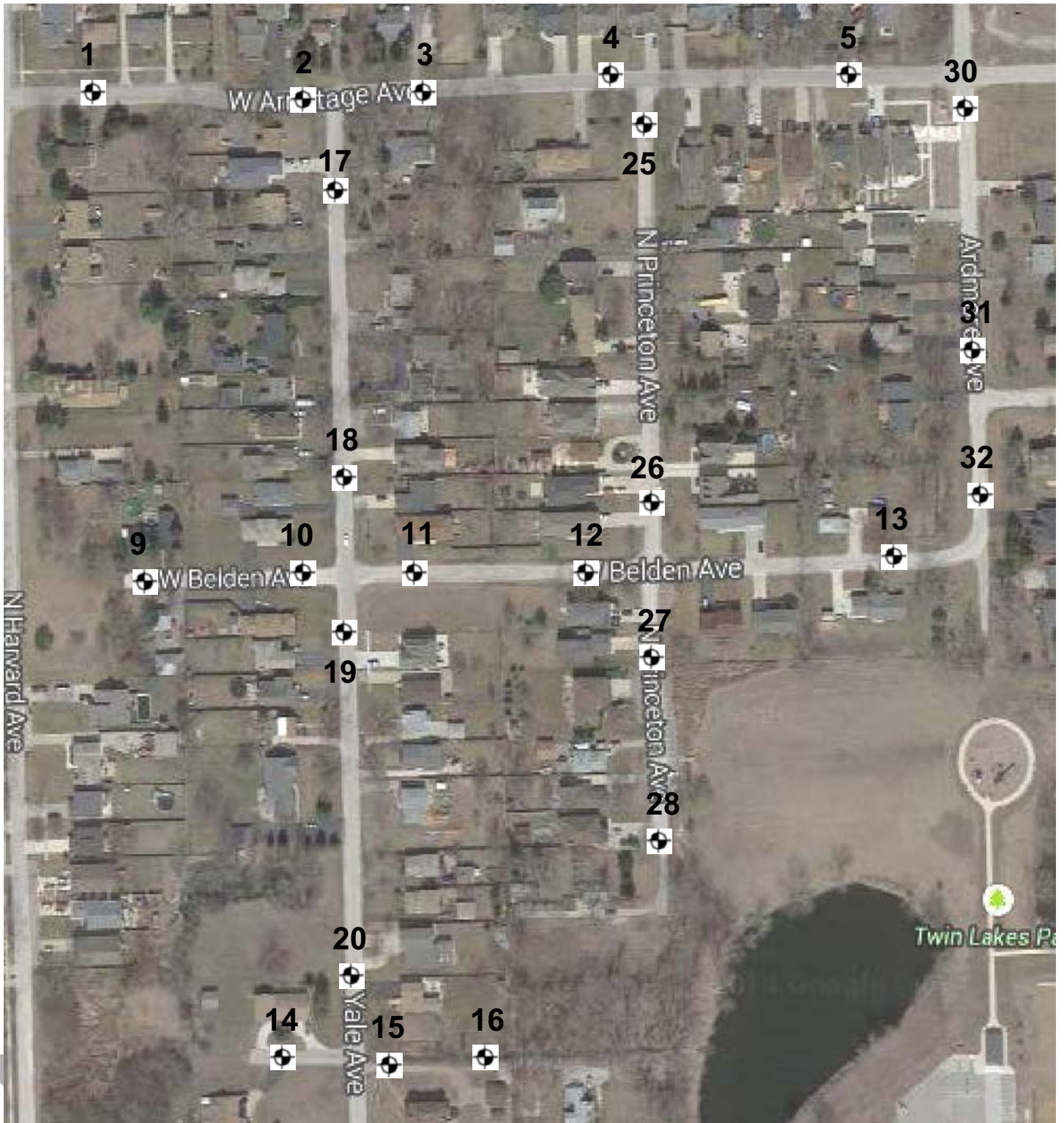

<b>SMC</b>		SOIL AND MATERIAL CONSULTANTS, INC.	<b>LOCATION SKETCH</b>
Client:	VILLAGE OF VILLA PARK		
Project:	GEOTECHNICAL YEAR 1 – GROUP 2		
Location:	VILLA PARK, ILLINOIS		
File No.	21873	Date: 01-19-15	Scale: NONE



NC



<b>SMC</b>		SOIL AND MATERIAL CONSULTANTS, INC.	<b>LOCATION SKETCH</b>
Client:	VILLAGE OF VILLA PARK		
Project:	GEOTECHNICAL YEAR 1 – GROUP 2		
Location:	VILLA PARK, ILLINOIS		
File No.	21873	Date: 01-19-15	Scale: NONE



<b>SMC</b>		SOIL AND MATERIAL CONSULTANTS, INC.	<b>LOCATION SKETCH</b>
Client:	VILLAGE OF VILLA PARK		
Project:	GEOTECHNICAL YEAR 1 – GROUP 2		
Location:	VILLA PARK, ILLINOIS		
File No.	21873	Date: 01-19-15	Scale: NONE

NOT FOR BID

**SOIL AND MATERIAL CONSULTANTS, INC.**

Date: 12/29/14

File No.: 21873

8 WEST COLLEGE DRIVE OFFICE: (847) 870-0544  
ARLINGTON HEIGHTS, IL 60004 FAX: (847) 870-0661

**CORE LOG**

Client: Village of Villa Park Reference Geotechnical Year 1 - Group 2

Core No: 1 Work Done By: DB & JL

Location of Core: 210 W. Armitage Avenue, 10' S. of CL

Comments:

(Depth, In.)	Type of Material	Recovery
0 ---		
1 ---		
2 ---	3-3/4" Bituminous concrete - surface	Full
3 ---		
4 ---		
5 ---	1-1/4" Bituminous concrete - surface	Full
6 ---		
7 ---		
8 ---		
9 ---		
10 ---	8-1/2" Crushed limestone with fines	Partial
11 ---		
12 ---		
13 ---		
14 ---	Total 13-1/2"	
15 ---	E.O.C.	
16 ---		
17 ---		
18 ---		
19 ---		
20 ---		

**SOIL AND MATERIAL CONSULTANTS, INC.**

Date: 12/29/15

File No.: 21873

8 WEST COLLEGE DRIVE OFFICE: (847) 870-0544  
ARLINGTON HEIGHTS, IL 60004 FAX: (847) 870-0661

**CORE LOG**

Client: Village of Villa Park Reference Geotechnical Year 1 - Group 2

Core No: 2 Work Done By: DB & JL

Location of Core: 230 W. Armitage Avenue, 6' N. of CL

Comments:

(Depth, In.)	Type of Material	Recovery
0 ---	1-0" Bituminous concrete - surface	Full
1 ---	Petromat	
0-1/2"	Bituminous concrete - surface	Full
2 ---		
2-1/2"	Bituminous concrete - surface	Full
3 ---		
4 ---		
4-1/2"	Crushed limestone with fines	Partial
5 ---		
6 ---		
7 ---		
8 ---		
9 ---		
10 ---		
11 ---	5-3/4" Emulsified soil & aggregate mixture	Partial
12 ---		
13 ---		
14 ---	Total 14-1/4"	
15 ---	E.O.C.	
16 ---		
17 ---		
18 ---		
19 ---		
20 ---		

**SOIL AND MATERIAL CONSULTANTS, INC.**

Date: 12/29/14

File No.: 21873

8 WEST COLLEGE DRIVE OFFICE: (847) 870-0544  
ARLINGTON HEIGHTS, IL 60004 FAX: (847) 870-0661

**CORE LOG**

Client: Village of Villa Park Reference Geotechnical Year 1 - Group 2

Core No: 3 Work Done By: DB & JL

Location of Core: 250 W. Armitage Avenue, 5' S. of CL

Comments: \_\_\_\_\_

(Depth, In.)	Type of Material	Recovery
0 ---	1-1/4" Bituminous concrete - surface Petromat	Full
1 ---		
2 ---	1-1/4" Bituminous concrete - surface	Full
3 ---	4-0" Bituminous concrete - binder	Full
4 ---		
5 ---		
6 ---	4-1/2" Crushed gravel with fines some broken asphalt	Partial
7 ---		
8 ---		
9 ---		
10 ---		
11 ---	Total 11-0"	
12 ---	E.O.C.	
13 ---		
14 ---		
15 ---		
16 ---		
17 ---		
18 ---		
19 ---		
20 ---		

**SOIL AND MATERIAL CONSULTANTS, INC.**

Date: 12/29/14

File No.: 21873

8 WEST COLLEGE DRIVE OFFICE: (847) 870-0544  
ARLINGTON HEIGHTS, IL 60004 FAX: (847) 870-0661

**CORE LOG**

Client: Village of Villa Park Reference Geotechnical Year 1 - Group 2

Core No: 4 Work Done By: DB & JL

Location of Core: 286 W. Armitage Avenue, 5' N. of CL

Comments:

(Depth, In.)	Type of Material	Recovery
0 ---	1-1/2" Bituminous concrete - surface	Full
1 ---	Petromat	
2 ---	0-3/4" Bituminous concrete - surface	Full
3 ---	2-1/4" Bituminous concrete - surface	Full
4 ---		
5 ---		
6 ---	3-1/4" Bituminous concrete - surface	Full
7 ---		
8 ---		
9 ---	3-3/4" Emulsified soil & aggregate mixture	Partial
10 ---		
11 ---	Total 11-1/2"	
12 ---	E.O.C.	
13 ---		
14 ---		
15 ---		
16 ---		
17 ---		
18 ---		
19 ---		
20 ---		

**SOIL AND MATERIAL CONSULTANTS, INC.**

Date: 12/29/14

File No.: 21873

8 WEST COLLEGE DRIVE OFFICE: (847) 870-0544  
ARLINGTON HEIGHTS, IL 60004 FAX: (847) 870-0661

**CORE LOG**

Client: Village of Villa Park Reference Geotechnical Year 1 - Group 2

Core No: 5 Work Done By: DB & JL

Location of Core: 23 E. Armitage Avenue, 7' S. of CL

Comments:

(Depth, In.)	Type of Material	Recovery
0 ---	1-1/4" Bituminous concrete - surface	Full
1 ---	Petromat	
2 ---	0-1/4" Bituminous concrete - surface no bond	Full
3 ---	2-0" Bituminous concrete - surface	Full
4 ---	1-3/4" Bituminous concrete - surface	Full
5 ---		
6 ---		
7 ---	4-3/4" Emulsified soil & aggregate mixture	Partial
8 ---		
9 ---		
10 ---	Total 10-0"	
11 ---	E.O.C.	
12 ---		
13 ---		
14 ---		
15 ---		
16 ---		
17 ---		
18 ---		
19 ---		
20 ---		

**SOIL AND MATERIAL CONSULTANTS, INC.**

Date: 12/29/14

File No.: 21873

8 WEST COLLEGE DRIVE OFFICE: (847) 870-0544  
ARLINGTON HEIGHTS, IL 60004 FAX: (847) 870-0661

**CORE LOG**

Client: Village of Villa Park Reference Geotechnical Year 1 - Group 2

Core No: 6 Work Done By: DB & JL

Location of Core: 1199 E. Armitage Avenue, 11' N. of CL (Crown Battery Bldg.)

Comments:

(Depth, In.)	Type of Material	Recovery
0 ---		
1 ---		
2 ---		
3 ---		
4 ---	8-0" Concrete	Full
5 ---		
6 ---		
7 ---		
8 ---		
9 ---		
10 ---	3-1/2" Crushed limestone with fines	Partial
11 ---	Total 11-1/2"	
12 ---	E.O.C.	
13 ---		
14 ---		
15 ---		
16 ---		
17 ---		
18 ---		
19 ---		
20 ---		

**SOIL AND MATERIAL CONSULTANTS, INC.**

Date: 12/29/14

File No.: 21873

8 WEST COLLEGE DRIVE OFFICE: (847) 870-0544  
ARLINGTON HEIGHTS, IL 60004 FAX: (847) 870-0661

**CORE LOG**

Client: Village of Villa Park Reference Geotechnical Year 1 - Group 2

Core No: 7 Work Done By: DB & JL

Location of Core: 650 E. Armitage Avenue, 8' S. of CL

Comments: \_\_\_\_\_

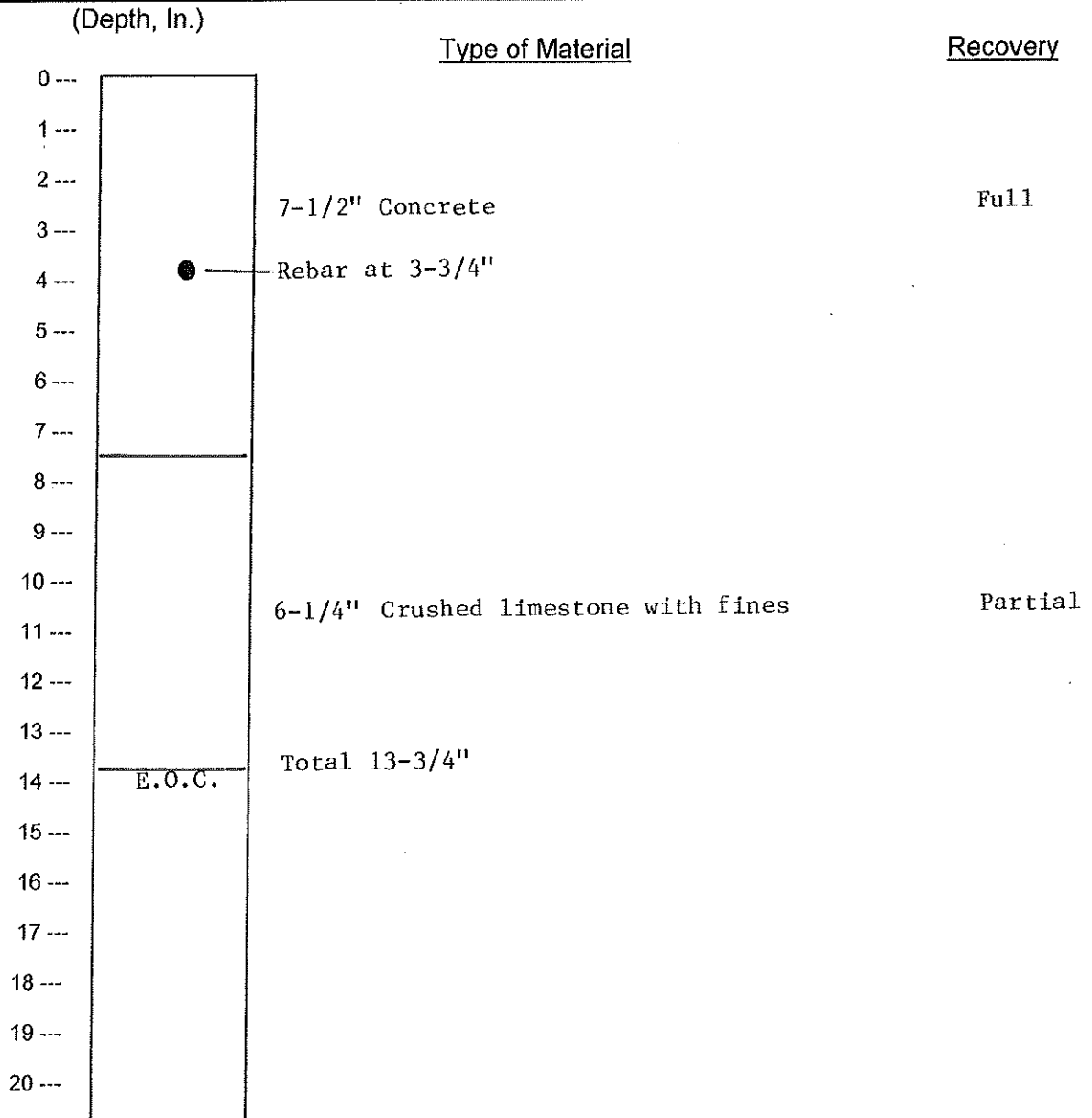

**SOIL AND MATERIAL CONSULTANTS, INC.**

Date: 12/29/14

File No.: 21873

8 WEST COLLEGE DRIVE OFFICE: (847) 870-0544  
ARLINGTON HEIGHTS, IL 60004 FAX: (847) 870-0661

**CORE LOG**

Client: Village of Villa Park Reference Geotechnical Year 1 - Group 2

Core No: 8 Work Done By: DB & JL

Location of Core: E. Armitage Avenue, 25' W. of Villa Avenue, 12' N. of CL

Comments: \_\_\_\_\_

(Depth, In.)	Type of Material	Recovery
0 ---		
1 ---		
2 ---		
3 ---		
4 ---	8-1/2" Concrete	Full
5 ---		
6 ---		
7 ---		
8 ---		
9 ---		
10 ---		
11 ---		
12 ---		
13 ---	15-1/2" Crushed limestone with fines	Partial
14 ---		
15 ---		
16 ---		
17 ---		
18 ---		
19 ---		
20 ---		
24 ---	Total 24-0"	

**SOIL AND MATERIAL CONSULTANTS, INC.**

Date: 12/29/14

File No.: 21873

8 WEST COLLEGE DRIVE OFFICE: (847) 870-0544  
ARLINGTON HEIGHTS, IL 60004 FAX: (847) 870-0661

**CORE LOG**

Client: Village of Villa Park Reference: Geotechnical Year 1 - Group 2

Core No: 9 Work Done By: DB & JL

Location of Core: 146 W. Belden Avenue, 5' S. of CL

Comments:

(Depth, In.)	Type of Material	Recovery
0 ---		
1 ---	2-0" Bituminous concrete - binder	Full
2 ---		
3 ---		
4 ---	5-0" Crushed gravel with fines	Partial
5 ---		
6 ---		
7 ---	Total 7-0"	
8 ---	E.O.C.	
9 ---		
10 ---		
11 ---		
12 ---		
13 ---		
14 ---		
15 ---		
16 ---		
17 ---		
18 ---		
19 ---		
20 ---		

**SOIL AND MATERIAL CONSULTANTS, INC.**

Date: 12/29/14

File No.: 21873

8 WEST COLLEGE DRIVE OFFICE: (847) 870-0544  
ARLINGTON HEIGHTS, IL 60004 FAX: (847) 870-0661

**CORE LOG**

Client: Village of Villa Park Reference Geotechnical Year 1 - Group 2

Core No: 10 Work Done By: DB & JL

Location of Core: 1044 W. Belden Avenue, 5' N. of CL

Comments: \_\_\_\_\_

(Depth, In.)	Type of Material	Recovery
0 ---	0-3/4" Bituminous concrete - surface	Full
1 ---	1-1/2" Bituminous concrete - binder	Full
2 ---		
3 ---		
4 ---		
5 ---		
6 ---		
7 ---	9-1/2" Crushed limestone with fines	Partial
8 ---		
9 ---		
10 ---		
11 ---		
12 ---	Total 11-3/4"	
13 ---	E.O.C.	
14 ---		
15 ---		
16 ---		
17 ---		
18 ---		
19 ---		
20 ---		

**SOIL AND MATERIAL CONSULTANTS, INC.**

Date: 12/29/14

File No.: 21873

8 WEST COLLEGE DRIVE OFFICE: (847) 870-0544  
ARLINGTON HEIGHTS, IL 60004 FAX: (847) 870-0661

**CORE LOG**

Client: Village of Villa Park Reference Geotechnical Year 1 - Group 2

Core No: 11 Work Done By: DB & JL

Location of Core: 1107 W. Belden Avenue, 4' S. of CL

Comments: \_\_\_\_\_

(Depth, In.)	Type of Material	Recovery
0 ---		
1 ---		
2 ---	3-1/2" Bituminous concrete - binder	Full
3 ---		
4 ---		
5 ---	4-0" Emulsified soil & aggregate mixture	Partial
6 ---		
7 ---	Total 7-1/2"	
8 ---	E.O.C.	
9 ---		
10 ---		
11 ---		
12 ---		
13 ---		
14 ---		
15 ---		
16 ---		
17 ---		
18 ---		
19 ---		
20 ---		

**SOIL AND MATERIAL CONSULTANTS, INC.**

Date: 12/29/14

File No.: 21873

8 WEST COLLEGE DRIVE OFFICE: (847) 870-0544  
ARLINGTON HEIGHTS, IL 60004 FAX: (847) 870-0661

**CORE LOG**

Client: Village of Villa Park Reference: Geotechnical Year 1 - Group 2

Core No: 12 Work Done By: DB & JL

Location of Core: W. Belden Avenue, 50' W. of Princeton Avenue, 6' N. of CL

Comments: \_\_\_\_\_

(Depth, In.)	Type of Material	Recovery
0 ---		
1 ---		
2 ---	3-3/4" Bituminous concrete - binder	Full
3 ---		
4 ---		
5 ---	4-0" Emulsified soil & aggregate mixture	Partial
6 ---		
7 ---		
8 ---		
9 ---		
10 ---		
11 ---	6-1/2" Crushed limestone with fines	Partial
12 ---		
13 ---		
14 ---	Total 14-1/4"	
15 ---	E.O.C.	
16 ---		
17 ---		
18 ---		
19 ---		
20 ---		

**SOIL AND MATERIAL CONSULTANTS, INC.**

Date: 12/29/14

File No.: 21873

8 WEST COLLEGE DRIVE OFFICE: (847) 870-0544  
ARLINGTON HEIGHTS, IL 60004 FAX: (847) 870-0661

**CORE LOG**

Client: Village of Villa Park Reference Geotechnical Year 1 - Group 2

Core No: 13 Work Done By: DB & JL

Location of Core: 41 W. Belden Avenue, 5' S. of CL

Comments: \_\_\_\_\_

(Depth, In.)	Type of Material	Recovery
0 ---		
1 ---		
2 ---	3-3/4" Bituminous concrete - binder	Full
3 ---		
4 ---		
5 ---		
6 ---	4-3/4" Crushed limestone with fines	Partial
7 ---		
8 ---		
9 ---	E.O.C. Total 8-1/2"	
10 ---		
11 ---		
12 ---		
13 ---		
14 ---		
15 ---		
16 ---		
17 ---		
18 ---		
19 ---		
20 ---		

**SOIL AND MATERIAL CONSULTANTS, INC.**

Date: 1/12/15

File No.: 21873

8 WEST COLLEGE DRIVE OFFICE: (847) 870-0544  
ARLINGTON HEIGHTS, IL 60004 FAX: (847) 870-0661

**CORE LOG**

Client: Village of Villa Park Reference Geotechnical Year 1 - Group 2

Core No.: 14 Work Done By: JL & BB

Location of Core: 150 W. Sidney Avenue, 4' N. of CL

Comments: \_\_\_\_\_

(Depth, In.)	Type of Material	Recovery
0 ---		
1 ---		
2 ---		
3 ---		
4 ---		
5 ---		
6 ---		
7 ---		
8 ---		
9 ---		
10 ---		
11 ---		
12 ---		
13 ---		
14 ---	E.O.C.	
15 ---		
16 ---		
17 ---		
18 ---		
19 ---		
20 ---		

2-3/4" Bituminous concrete - binder Full

10-3/4" Limestone/sand/asphalt mixture contaminated with clay Partial

Total 13-1/2"

**SOIL AND MATERIAL CONSULTANTS, INC.**

Date: 1/12/15

8 WEST COLLEGE DRIVE OFFICE: (847) 870-0544  
 ARLINGTON HEIGHTS, IL 60004 FAX: (847) 870-0661

File No.: 21873

**CORE LOG**

Client: Village of Villa Park Reference Geotechnical Year 1 - Group 2

Core No: 15 Work Done By: JL & BB

Location of Core: Sidney Avenue, 50' E. of Yale Avenue, 3' N. of CL

Comments: \_\_\_\_\_

(Depth, In.)	<u>Type of Material</u>	<u>Recovery</u>
0 ---		
1 ---	2-1/2" Bituminous concrete - binder	Full
2 ---		
3 ---		
4 ---		
5 ---		
6 ---		
7 ---		
8 ---		
9 ---		
10 ---	37-1/2" Crushed limestone with fines	Partial
11 ---		
12 ---		
13 ---		
14 ---		
15 ---		
16 ---		
17 ---		
18 ---		
19 ---		
20 ---		
60 ---	Total 60-0"	

**SOIL AND MATERIAL CONSULTANTS, INC.**

Date: 1/12/15

File No.: 21873

8 WEST COLLEGE DRIVE OFFICE: (847) 870-0544  
 ARLINGTON HEIGHTS, IL 60004 FAX: (847) 870-0661

**CORE LOG**

Client: Village of Villa Park Reference Geotechnical Year 1 - Group 2

Core No: 16 Work Done By: JL & BB

Location of Core: Sidney Avenue, 235' E. of Yale Avenue, 2' S. of CL

Comments: \_\_\_\_\_

(Depth, In.)	Type of Material	Recovery
0 ---		
1 ---	1-3/4" Bituminous concrete - binder	Full
2 ---		no bond
3 ---		
4 ---		
5 ---		
6 ---		
7 ---		
8 ---		
9 ---	21-1/4" Sand/grave/crushed asphalt mixture	Partial
10 ---		
11 ---		
12 ---		
13 ---		
14 ---		
15 ---		
16 ---		
17 ---		
18 ---		
19 ---		
20 ---		
23 --	Total 23-0+" E.O.C.	

**SOIL AND MATERIAL CONSULTANTS, INC.**

Date: 1/12/15

8 WEST COLLEGE DRIVE OFFICE: (847) 870-0544  
ARLINGTON HEIGHTS, IL 60004 FAX: (847) 870-0661

File No.: 21873

**CORE LOG**

Client: Village of Villa Park Reference: Geotechnical Year 1 - Group 2

Core No: 17 Work Done By: JL & BB

Location of Core: 1142 Yale Avenue, 7' W. of CL

Comments: \_\_\_\_\_

(Depth, In.)	Type of Material	Recovery
0 ---		
1 ---	2-0" Bituminous concrete - surface	Full
2 ---	no bond	
3 ---	2-0" Bituminous concrete - binder	Full
4 ---		
5 ---		
6 ---	3-0" Bituminous treated aggregate	Partial
7 ---		
8 ---		
9 ---	6-1/2" Crushed limestone with fines	Partial
10 ---		
11 ---		
12 ---		
13 ---		
14 ---	E.O.C. Total 13-1/2"	
15 ---		
16 ---		
17 ---		
18 ---		
19 ---		
20 ---		

**SOIL AND MATERIAL CONSULTANTS, INC.**

Date: 1/12/15

File No.: 21873

8 WEST COLLEGE DRIVE OFFICE: (847) 870-0544  
ARLINGTON HEIGHTS, IL 60004 FAX: (847) 870-0661

**CORE LOG**

Client: Village of Villa Park Reference Geotechnical Year 1 - Group 2

Core No: 18 Work Done By: JL & BB

Location of Core: 1115 Yale Avenue, 5' E. of CL

Comments: \_\_\_\_\_

(Depth, In.)	Type of Material	Recovery
0 ---		
1 ---	1-3/4" Bituminous concrete - surface	Full
2 ---	no bond	
3 ---	1-1/4" Bituminous concrete - binder (failed)	Partial
4 ---		
5 ---	2-3/4" Bituminous treated aggregate	Full
6 ---		
7 ---		
8 ---	3-1/4" Crushed limestone with fines	Partial
9 ---	Total 9-0"	
10 ---	E.O.C.	
11 ---		
12 ---		
13 ---		
14 ---		
15 ---		
16 ---		
17 ---		
18 ---		
19 ---		
20 ---		

**SOIL AND MATERIAL CONSULTANTS, INC.**

8 WEST COLLEGE DRIVE OFFICE: (847) 870-0544  
ARLINGTON HEIGHTS, IL 60004 FAX: (847) 870-0661

Date: 1/12/15

File No.: 21873

**CORE LOG**

Client: Village of Villa Park Reference Geotechnical Year 1 - Group 2  
Core No: 19 Work Done By: DB & JL  
Location of Core: 1043 Yale Avenue, 10' W. of CL

Comments:

(Depth, In.)	Type of Material	Recovery
0 ---		
1 ---	1-3/4" Bituminous concrete - surface	Full
2 ---		
3 ---	2-0" Bituminous concrete - binder	Full
4 ---		
5 ---	3-3/4" Bituminous treated aggregate (failed)	Partial
6 ---		
7 ---		
8 ---		
9 ---	2-0" Crushed limestone with fines	Partial
10 ---	Total 9-1/2"	
11 ---	E.O.C.	
12 ---		
13 ---		
14 ---		
15 ---		
16 ---		
17 ---		
18 ---		
19 ---		
20 ---		

**SOIL AND MATERIAL CONSULTANTS, INC.**

Date: 1/12/15

File No.: 21873

8 WEST COLLEGE DRIVE OFFICE: (847) 870-0544  
 ARLINGTON HEIGHTS, IL 60004 FAX: (847) 870-0661

**CORE LOG**

Client: Village of Villa Park Reference Geotechnical Year 1 - Group 2

Core No: 20 Work Done By: JL & BB

Location of Core: 1001 Yale Avenue, 5' E. of CL

Comments: \_\_\_\_\_

(Depth, In.)	Type of Material	Recovery
0 ---		
1 ---		
2 ---	2-1/4" Bituminous concrete - surface	Full
3 ---		
4 ---	5-0" Bituminous treated aggregate	Full
5 ---		
6 ---		
7 ---		
8 ---		
9 ---		
10 ---	4-3/4" Crushed limestone with fines	Partial
11 ---		
12 ---	Total 12-0"	
13 ---	E.O.C.	
14 ---		
15 ---		
16 ---		
17 ---		
18 ---		
19 ---		
20 ---		

**SOIL AND MATERIAL CONSULTANTS, INC.**

Date: 1/12/15

File No.: 21873

8 WEST COLLEGE DRIVE OFFICE: (847) 870-0544  
ARLINGTON HEIGHTS, IL 60004 FAX: (847) 870-0661

**CORE LOG**

Client: Village of Villa Park Reference Geotechnical Year 1 - Group 2

Core No: 21 Work Done By: JL & BB

Location of Core: 951 Yale Avenue, 6' W. of CL

Comments: \_\_\_\_\_

(Depth, In.)	Type of Material	Recovery
0 ---		
1 ---	2-0" Bituminous concrete - surface	Full
2 ---		
3 ---		
4 ---		
5 ---		
6 ---	8-0" Bituminous treated aggregate (failed)	Partial
7 ---		
8 ---		
9 ---		
10 ---		
11 ---	1-1/2" Built-up surface treatments (failed)	Partial
12 ---		
13 ---	3-1/4" Crushed limestone with fines, some large	Partial
14 ---		
15 ---	Total 14-3/4" E.O.C.	
16 ---		
17 ---		
18 ---		
19 ---		
20 ---		

**SOIL AND MATERIAL CONSULTANTS, INC.**

Date: 1/12/15

File No.: 21873

8 WEST COLLEGE DRIVE OFFICE: (847) 870-0544  
ARLINGTON HEIGHTS, IL 60004 FAX: (847) 870-0661

**CORE LOG**

Client: Village of Villa Park Reference Geotechnical Year 1 - Group 2

Core No: 22 Work Done By: JL & BB

Location of Core: 932 Yale Avenue, 6' E. of CL

Comments: \_\_\_\_\_

(Depth, In.)	Type of Material	Recovery
0 ---		
1 ---	2-1/4" Bituminous concrete - surface	Full
2 ---		
3 ---		
4 ---	5-1/4" Bituminous treated aggregate	Full
5 ---		
6 ---		
7 ---		
8 ---		
9 ---	3-1/2" Crushed limestone with fines	Partial
10 ---		
11 ---	Total 11-0"	
12 ---	E.O.C.	
13 ---		
14 ---		
15 ---		
16 ---		
17 ---		
18 ---		
19 ---		
20 ---		

**SOIL AND MATERIAL CONSULTANTS, INC.**

Date: 1/12/15

File No.: 21873

8 WEST COLLEGE DRIVE OFFICE: (847) 870-0544  
ARLINGTON HEIGHTS, IL 60004 FAX: (847) 870-0661

**CORE LOG**

Client: Village of Villa Park Reference Geotechnical Year 1 - Group 2

Core No: 23 Work Done By: JL & BB

Location of Core: 911 Yale Avenue, 4' W. of CL

Comments: \_\_\_\_\_

(Depth, In.)	Type of Material	Recovery
0 ---		
1 ---	2-0" Bituminous concrete - surface	Full
2 ---		
3 ---	1-3/4" Bituminous concrete - binder	Full
4 ---		
5 ---		
6 ---		
7 ---	6-3/4" Crushed limestone & asphalt with fines	Partial
8 ---		
9 ---		
10 ---	Total 10-1/2"	
11 ---	E.O.C.	
12 ---		
13 ---		
14 ---		
15 ---		
16 ---		
17 ---		
18 ---		
19 ---		
20 ---		

**SOIL AND MATERIAL CONSULTANTS, INC.**

Date: 1/12/15

File No.: 21873

8 WEST COLLEGE DRIVE OFFICE: (847) 870-0544  
ARLINGTON HEIGHTS, IL 60004 FAX: (847) 870-0661

**CORE LOG**

Client: Village of Villa Park Reference Geotechnical Year 1 - Group 2

Core No: 24 Work Done By: JL & BB

Location of Core: 835 Yale Avenue, 6' E. of CL

Comments: \_\_\_\_\_

(Depth, In.)	Type of Material	Recovery
0 ---		
1 ---	2-0" Bituminous concrete - surface	Full
2 ---		
3 ---		
4 ---	6-0" Bituminous treated aggregate	Full
5 ---		
6 ---		
7 ---		
8 ---		
9 ---		
10 ---	4-0" Crushed limestone with fines	Partial
11 ---		
12 ---	Total 12-0"	
13 ---	E.O.C.	
14 ---		
15 ---		
16 ---		
17 ---		
18 ---		
19 ---		
20 ---		

**SOIL AND MATERIAL CONSULTANTS, INC.**

Date: 1/12/15

File No.: 21873

8 WEST COLLEGE DRIVE OFFICE: (847) 870-0544  
ARLINGTON HEIGHTS, IL 60004 FAX: (847) 870-0661

**CORE LOG**

Client: Village of Villa Park Reference Geotechnical Year 1 - Group 2

Core No: 25 Work Done By: JL & BB

Location of Core: Princeton Avenue, 50' S. of Armitage Avenue, 6' W. of CL

Comments: \_\_\_\_\_

(Depth, In.)	Type of Material	Recovery
0 ---		
1 ---		
2 ---	4-0" Bituminous concrete - binder	Full
3 ---		
4 ---		
5 ---	2-1/2" Crushed limestone with fines	Partial
6 ---		
7 ---	Total 6-1/2" E.O.C.	
8 ---		
9 ---		
10 ---		
11 ---		
12 ---		
13 ---		
14 ---		
15 ---		
16 ---		
17 ---		
18 ---		
19 ---		
20 ---		

**SOIL AND MATERIAL CONSULTANTS, INC.**

Date: 1/12/15

File No.: 21873

8 WEST COLLEGE DRIVE OFFICE: (847) 870-0544  
ARLINGTON HEIGHTS, IL 60004 FAX: (847) 870-0661

**CORE LOG**

Client: Village of Villa Park Reference Geotechnical Year 1 - Group 2

Core No: 26 Work Done By: JL & BB

Location of Core: 1105 Princeton Avenue, 5' E. of CL

Comments: \_\_\_\_\_

(Depth, In.)	Type of Material	Recovery
0 ---		
1 ---		
2 ---	3-1/4" Bituminous concrete - binder	Full
3 ---		
4 ---	3-0" Crushed limestone with fines	Partial
5 ---		
6 ---	Total 6-1/4"	
7 ---	E.O.C.	
8 ---		
9 ---		
10 ---		
11 ---		
12 ---		
13 ---		
14 ---		
15 ---		
16 ---		
17 ---		
18 ---		
19 ---		
20 ---		

**SOIL AND MATERIAL CONSULTANTS, INC.**

Date: 1/12/15

File No.: 21873

8 WEST COLLEGE DRIVE OFFICE: (847) 870-0544  
ARLINGTON HEIGHTS, IL 60004 FAX: (847) 870-0661

**CORE LOG**

Client: Village of Villa Park Reference Geotechnical Year 1 - Group 2

Core No: 27 Work Done By: JL & BB

Location of Core: 1036 Princeton Avenue, 5' W. of CL

Comments: \_\_\_\_\_

(Depth, In.)	Type of Material	Recovery
0 --		
1 --	1-1/4" Bituminous concrete - surface	Full
2 --	2-0" Bituminous concrete - binder	Full
3 --		
4 --		
5 --		
6 --		
7 --		
8 --		
9 --	32-3/4" Crushed gravel with fines	Partial
10 --		
11 --		
12 --		
13 --		
14 --		
15 --		
16 --		
17 --		
18 --		
19 --		
20 --		
36 --	Total 36-0"	

**SOIL AND MATERIAL CONSULTANTS, INC.**

Date: 1/12/15

File No.: 21873

8 WEST COLLEGE DRIVE OFFICE: (847) 870-0544  
 ARLINGTON HEIGHTS, IL 60004 FAX: (847) 870-0661

**CORE LOG**

Client: Village of Villa Park Reference Geotechnical Year 1 - Group 2

Core No: 28 Work Done By: JL & BB

Location of Core: 1022 Princeton Avenue, 4' E. of CL

Comments: \_\_\_\_\_

(Depth, In.)	<u>Type of Material</u>	<u>Recovery</u>
0 ---		
1 ---	2-1/4" Bituminous concrete - surface	Full
2 ---		
3 ---		
4 ---	3-1/2" Bituminous concrete - binder	Full
5 ---		
6 ---		
7 ---		
8 ---	4-1/4" Crushed limestone with fines	Partial
9 ---		
10 ---	Total 10-0"	
11 ---	E.O.C.	
12 ---		
13 ---		
14 ---		
15 ---		
16 ---		
17 ---		
18 ---		
19 ---		
20 ---		

**SOIL AND MATERIAL CONSULTANTS, INC.**

Date: 1/12/15

File No.: 21873

8 WEST COLLEGE DRIVE OFFICE: (847) 870-0544  
ARLINGTON HEIGHTS, IL 60004 FAX: (847) 870-0661

**CORE LOG**

Client: Village of Villa Park Reference Geotechnical Year 1 - Group 2

Core No: 29 Work Done By: JL & BB

Location of Core: 837 Princeton Avenue, 5' E. of CL

Comments: \_\_\_\_\_

(Depth, In.)	Type of Material	Recovery
0 ---	1-3/4" Bituminous concrete - surface	Partial
1 ---		
2 ---	82-1/4" Crushed limestone with fines	Partial
3 ---		
4 ---		
5 ---		
6 ---		
7 ---		
8 ---		
9 ---		
10 ---		
11 ---		
12 ---		
13 ---		
14 ---		
15 ---		
16 ---		
17 ---		
18 ---		
19 ---		
20 ---		
84 ---	Total 84-0"	

E.O.C.

**SOIL AND MATERIAL CONSULTANTS, INC.**

Date: 12/29/14

File No.: 21873

8 WEST COLLEGE DRIVE OFFICE: (847) 870-0544  
ARLINGTON HEIGHTS, IL 60004 FAX: (847) 870-0661

**CORE LOG**

Client: Village of Villa Park Reference Geotechnical Year 1 - Group 2

Core No: 30 Work Done By: DB & JL

Location of Core: 1144 Ardmore Avenue, 6' W. of CL

Comments: \_\_\_\_\_

(Depth, In.)	Type of Material	Recovery
0 ---	1-1/4" Bituminous concrete - surface	Full
1 ---	Petromat	
2 ---	1-0" Bituminous concrete - surface	Full
3 ---		
4 ---	3-0" Bituminous concrete - binder	Full
5 ---		
6 ---		
7 ---		
8 ---	4-3/4" Crushed & uncrushed gravel with fines some asphalt pieces	Partial
9 ---		
10 ---	Total 10-0"	
11 ---	E.O.C.	
12 ---		
13 ---		
14 ---		
15 ---		
16 ---		
17 ---		
18 ---		
19 ---		
20 ---		

**SOIL AND MATERIAL CONSULTANTS, INC.**

Date: 12/29/14

File No.: 21873

8 WEST COLLEGE DRIVE OFFICE: (847) 870-0544  
ARLINGTON HEIGHTS, IL 60004 FAX: (847) 870-0661

**CORE LOG**

Client: Village of Villa Park Reference Geotechnical Year 1 - Group 2

Core No: 31 Work Done By: DB & JL

Location of Core: 1128 Ardmore Avenue, 7' E. of CL

Comments: \_\_\_\_\_

(Depth, In.)	Type of Material	Recovery
0 ---	1-1/2" Bituminous concrete - surface	Full
1 ---	Petromat	
2 ---	0-3/4" Bituminous concrete - surface no bond	Full
3 ---	1-1/2" Bituminous concrete - surface	Full
4 ---	1-1/2" Bituminous concrete - surface	Full
5 ---		
6 ---	2-1/4" Bituminous concrete - surface	Full
7 ---		
8 ---	1-3/4" Emulsified soil & aggregate mixture	Partial
9 ---	Total 9-1/4"	
10 ---	E.O.C.	
11 ---		
12 ---		
13 ---		
14 ---		
15 ---		
16 ---		
17 ---		
18 ---		
19 ---		
20 ---		

**SOIL AND MATERIAL CONSULTANTS, INC.**

Date: 12/29/14

8 WEST COLLEGE DRIVE OFFICE: (847) 870-0544  
 ARLINGTON HEIGHTS, IL 60004 FAX: (847) 870-0661

File No.: 21873

**CORE LOG**

Client: Village of Villa Park Reference Geotechnical Year 1 - Group 2

Core No: 32 Work Done By: DB & JL

Location of Core: 881 Ardmore Avenue, 4' W. of CL

Comments: \_\_\_\_\_

(Depth, In.)	Type of Material	Recovery
0 ---		
1 ---	1-1/4" Bituminous concrete - surface Petromat	Full
2 ---	1-0" Bituminous concrete - surface	Full
3 ---		
4 ---	3-3/4" Bituminous concrete - surface	Full
5 ---		
6 ---		
7 ---		
8 ---	5-1/4" Emulsified soil & aggregate mixture	Partial
9 ---		
10 ---		
11 ---	Total 11-1/4"	
12 ---	E.O.C.	
13 ---		
14 ---		
15 ---		
16 ---		
17 ---		
18 ---		
19 ---		
20 ---		

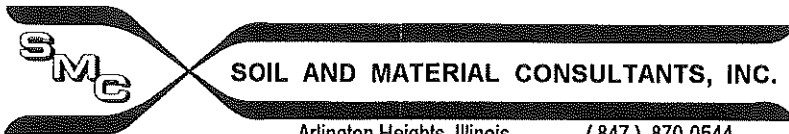

Arlington Heights, Illinois (847) 870-0544

# SOIL BORING LOG 1

Logged By: DB

Page: 1 of 1

Client: Village of Villa Park

File No. 21873

Date Drilled: 1/13/15

Reference: Geotechnical Year 1 - Group 2  
Villa Park, IL

Comments: 210 W. Armitage Ave., 10' S. of CL

Equipment:  CME 45B  CME 55  Hand Auger  Other

CLASSIFICATION  
Elevation Existing Surface

depth, ft.	(See Core Log)
1	
2	Black silt, some clay, trace sand & roots, damp, medium dense (topsoil) (frozen to 2.5')
3	Dark brown-brown-black clay, some silt, trace sand & gravel, damp-very damp, tough
4	
5	
6	
7	End of Boring
8	
9	
10	

standard penetration	moisture content	dry unit weight lbs./cu.ft.	unconfined compressive strength	unconfined compressive strength, tons/sq.ft.			
×	Δ	⊗	○	1.0	2.0	3.0	4.0
15	27.7				X	Δ	
6	25.0	98.6	1.3	●	X	○	Δ
4	34.1				X		Δ

○ unconfined compressive strength, tons/sq.ft.  
● penetrometer reading, tons/sq.ft.  
X standard penetration "N", blows/ft.  
Δ moisture content, %

Water encountered at dry feet during drilling operations (W.D.).  
Water recorded at dry feet on completion of drilling operations (A.D.).  
Water recorded at feet hours after completion of drilling operations (A.D.).



**SOIL AND MATERIAL CONSULTANTS, INC.**

Arlington Heights, Illinois (847) 870-0544

**SOIL BORING LOG** 2

Logged By: DB

Page: 1 of 1

Client: Village of Villa Park

File No. 21873

Date Drilled: 1/13/15

Reference: Geotechnical Year 1 - Group 2  
Villa Park, IL

Comments: 230 W. Armitage Ave., 6' N. of CL

Equipment:  CME 45B  CME 55  Hand Auger  Other

CLASSIFICATION  
Elevation Existing Surface

depth, ft	(See Core Log)
1	Black silt, some clay, trace roots, damp (topsoil) (frozen to 2.0')
2	Dark brown to brown-gray clay, some silt, trace sand & gravel, damp, very tough
3	
4	Brown-gray clay & silt, some fine sand, trace gravel, damp, soft
5	Brown-gray clay, some silt, trace sand & gravel, damp, very tough
6	
7	End of Boring
8	
9	
10	

standard penetration	moisture content	dry unit weight lbs./cu.ft.	unconfined compressive strength	<input type="checkbox"/> unconfined compressive strength, tons/sq.ft. <input checked="" type="checkbox"/> penetrometer reading, tons/sq.ft. 1.0 2.0 3.0 4.0 <input checked="" type="checkbox"/> standard penetration "N", blows/ft. <input checked="" type="checkbox"/> moisture content, % 10 20 30 40			
X	Δ	⊗	○				
18	25.9						
	21.7	105.0	3.5	X	Δ	●	
5	21.8						
	22.0	101.4	2.0	X	Δ	●	
7	18.4	115.1	2.9	X	Δ	●	○

Water encountered at dry feet during drilling operations (W.D.).  
 Water recorded at dry feet on completion of drilling operations (A.D.).  
 Water recorded at feet hours after completion of drilling operations (A.D.).

Client: Village of Villa Park

File No. 21873

Date Drilled: 1/13/15

Reference: Geotechnical Year 1 - Group 2  
Villa Park, IL

Comments: 250 W. Armitage Ave., 5' S. of CL

depth, ft	Equipment: <input checked="" type="checkbox"/> CME 45B <input type="checkbox"/> CME 55 <input type="checkbox"/> Hand Auger <input type="checkbox"/> Other		standard penetration	moisture content	dry unit weight lbs./cu.ft.	unconfined compressive strength	<input type="checkbox"/> unconfined compressive strength, tons/sq.ft. <input checked="" type="checkbox"/> penetrometer reading, tons/sq.ft. 1.0 2.0 3.0 4.0												
	Elevation	Existing Surface					X	Δ	×	○	10	20	30	40					
	(See Core Log)																		
1	Black silt, some clay, trace roots, damp (topsoil) (frozen to 2.0')																		
2	Dark brown to brown-gray clay, some silt, trace sand & gravel, damp, hard		19	21.1 23.7	99.6	4.5													4.5
3																			
4	Dark brown to brown-gray clay, some silt, trace sand & gravel, damp, tough																		
5	Brown-gray clay & silt, trace gravel, damp, soft		5	20.1	106.5	1.8													
6																			
7	Brown-gray clay, some silt, trace sand & gravel, damp, very tough		5	24.2 23.9	102.8	3.1													
	End of Boring																		
8																			
9																			
10																			

Water encountered at dry feet during drilling operations (W.D.).  
 Water recorded at dry feet on completion of drilling operations (A.D.).  
 Water recorded at feet hours after completion of drilling operations (A.D.).

Client: Village of Villa Park

File No. 21873 Date Drilled: 1/13/15

Reference: Geotechnical Year 1 - Group 2  
Villa Park, IL

Comments: 286 W. Armitage Ave., 5' N. of CL

depth, ft.	Equipment: <input checked="" type="checkbox"/> CME 45B <input type="checkbox"/> CME 55 <input type="checkbox"/> Hand Auger <input type="checkbox"/> Other	standard penetration	moisture content	dry unit weight lbs./cu.ft.	unconfined compressive strength	<input type="checkbox"/> unconfined compressive strength, tons/sq.ft. <input checked="" type="checkbox"/> penetrometer reading, tons/sq.ft. 1.0 2.0 3.0 4.0													
	CLASSIFICATION					Elevation	Existing Surface	<input checked="" type="checkbox"/> standard penetration "N", blows/ft. <input checked="" type="checkbox"/> moisture content, % 10 20 30 40											
	(See Core Log)																		
1	Black silt, some clay, trace roots, damp, medium dense (topsoil) (frozen to 3.0')																		
2																			
3	Brown to brown-gray clay, some silt, trace sand & gravel, damp, very tough	17	31.3																
4																			
5	Brown clay & silt, some fine sand, trace gravel, very damp, soft	6	19.9	107.5	2.5														
6																			
7	Brown-gray clay, some silt, trace sand & gravel, damp, very tough	6	24.6		3.4														
	End of Boring		20.5	107.6															
8																			
9																			
10																			

Water encountered at dry feet during drilling operations (W.D.).  
 Water recorded at dry feet on completion of drilling operations (A.D.).  
 Water recorded at feet hours after completion of drilling operations (A.D.).

Client: Village of Villa Park

File No. 21873 Date Drilled: 1/13/15

Reference: Geotechnical Year 1 - Group 2  
Villa Park, IL

Comments: 23 E. Armitage Ave., 7' S. of CL

depth, ft.	Equipment: <input checked="" type="checkbox"/> CME 45B <input type="checkbox"/> CME 55 <input type="checkbox"/> Hand Auger <input type="checkbox"/> Other	standard penetration	moisture content	dry unit weight lbs./cu.ft.	unconfined compressive strength	<input type="radio"/> unconfined compressive strength, tons/sq.ft. <input checked="" type="radio"/> penetrometer reading, tons/sq.ft. 1.0 2.0 3.0 4.0				
	CLASSIFICATION					<input checked="" type="checkbox"/> standard penetration "N", blows/ft. <input checked="" type="checkbox"/> moisture content, %	10	20	30	40
Elevation	Existing Surface	X	Δ	γ	○					
	(See Core Log)									
1	Black silt, some clay, trace roots, damp (topsoil) (frozen to 2.5')									
2	Dark brown-brown clay, some silt, trace sand & gravel, damp, hard	23	28.4 22.4	102.4	4.4					4.4
3										
4	Brown-gray clay, some silt, trace sand & gravel, damp, hard									
5		15	17.4	112.6	6.1					5.1
6										
7	End of Boring	11	19.0	114.4	4.9					4.9
8										
9										
10										

Water encountered at dry feet during drilling operations (W.D.).  
 Water recorded at dry feet on completion of drilling operations (A.D.).  
 Water recorded at feet hours after completion of drilling operations (A.D.).

Client: Village of Villa Park

File No. 21873 Date Drilled: 1/13/15

Reference: Geotechnical Year 1 - Group 2  
Villa Park, IL

Comments: 1199 E. Armitage Ave., 11' N. of CL

Equipment:  CME 45B  CME 55  Hand Auger  Other

CLASSIFICATION  
Elevation Existing Surface

depth, ft	(See Core Log)
1	Brown-gray-black clay, some silt, trace sand & gravel, damp, very tough to hard (frozen to 2.0')
2	
3	
4	
5	
6	
7	End of Boring
8	
9	
10	

standard penetration	moisture content	dry unit weight lbs./cu.ft.	unconfined compressive strength	<input type="radio"/> unconfined compressive strength, tons/sq.ft. <input checked="" type="radio"/> penetrometer reading, tons/sq.ft. 1.0 2.0 3.0 4.0 <input checked="" type="checkbox"/> standard penetration "N", blows/ft. <input checked="" type="checkbox"/> moisture content, % 10 20 30 40			
X	Δ	γ	○				
19	18.6	103.9	2.0				
9	17.7	112.1	4.5	X	Δ	●	○ 4.5
20	18.5	113.6	5.7		X		○ 5.1

Water encountered at dry feet during drilling operations (W.D.).  
 Water recorded at dry feet on completion of drilling operations (A.D.).  
 Water recorded at feet hours after completion of drilling operations (A.D.).

Client: Village of Villa Park

File No. 21873 Date Drilled: 1/13/15

Reference: Geotechnical Year 1 - Group 2  
Villa Park, IL

Comments: 650 E. Armitage Ave., 8' S. of CL

Equipment:  CME 45B  CME 55  Hand Auger  Other

CLASSIFICATION

Elevation Existing Surface

depth, ft.	(See Core Log)
1	Dark brown to brown-gray clay, some silt, trace sand & gravel, very tough to hard
2	
3	
4	
5	
6	
7	
8	
9	
10	

standard penetration	moisture content	dry unit weight lbs./cu.ft.	unconfined compressive strength	<input type="radio"/> unconfined compressive strength, tons/sq.ft. <input checked="" type="radio"/> penetrometer reading, tons/sq.ft. 1.0 2.0 3.0 4.0				
X	Δ	γ	○	X	standard penetration "N", blows/ft. Δ moisture content, %			
					10	20	30	40
18	24.9	98.4	2.5	X				
13	18.6	113.9	5.9	X				5.9 ○
15	19.3	111.9	4.6	X				4.6 ○

Water encountered at dry feet during drilling operations (W.D.)  
 Water recorded at dry feet on completion of drilling operations (A.D.)  
 Water recorded at feet hours after completion of drilling operations (A.D.)

Client: Village of Villa Park

File No. 21873

Date Drilled: 1/13/15

Reference: Geotechnical Year 1 - Group 2  
Villa Park, IL  
E. Armitage Ave., 25' W. of Villa  
Ave., 12' N. of CL

Comments: Equipment:  CME 45B  CME 55  Hand Auger  Other

depth, ft.	Equipment: <input checked="" type="checkbox"/> CME 45B <input type="checkbox"/> CME 55 <input type="checkbox"/> Hand Auger <input type="checkbox"/> Other	standard penetration	moisture content	dry unit weight lbs./cu.ft.	unconfined compressive strength	unconfined compressive strength, tons/sq.ft.			
	CLASSIFICATION					Elevation	Existing Surface	○	●
		×	△	⊗	○	penetrometer reading, tons/sq.ft.			
						standard penetration "N", blows/ft.			
						moisture content, %			
						10	20	30	40
1	(See Core Log)								
2	Dark brown-brown-black clay, some silt, trace sand & gravel, damp, very tough								
3									
4	Brown-gray clay, some silt, trace sand & gravel, damp, very tough to hard	12	22.0	100.5	2.2	×	●		
5		9	20.5	108.5	3.6	×	●	○	
6									
7	End of Boring	12	20.7	109.8	4.3	×	△		○
8									
9									
10									

Water encountered at dry feet during drilling operations (W.D.).  
Water recorded at dry feet on completion of drilling operations (A.D.).  
Water recorded at feet hours after completion of drilling operations (A.D.).

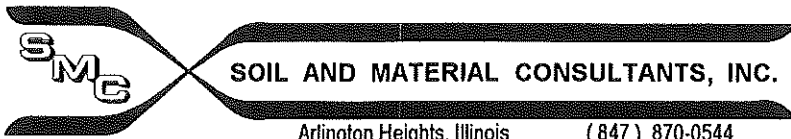

Arlington Heights, Illinois (847) 870-0544

# SOIL BORING LOG 9

Logged By: DB

Page: 1 of 1

Client: Village of Villa Park

File No. 21873

Date Drilled: 1/19/15

Reference: Geotechnical Year 1 - Group 2  
Villa Park, IL

Comments: 146 W. Belden Ave., 5' S. of CL

Equipment:  CME 45B  CME 55  Hand Auger  Other

CLASSIFICATION  
Elevation Existing Surface

(See Core Log)	
1	Black silt, some clay, trace sand & roots, damp (topsoil)
2	Brown clay, some silt, trace sand & gravel, damp, hard (frozen to 2.0')
3	
4	End of Boring
5	
6	End of Boring
7	
8	End of Boring
9	
10	End of Boring

standard penetration	moisture content	dry unit weight lbs./cu.ft.	unconfined compressive strength	<input type="radio"/> unconfined compressive strength, tons/sq.ft. <input checked="" type="radio"/> penetrometer reading, tons/sq.ft. 1.0 2.0 3.0 4.0			
×	△	⊗	○	×	△	<input type="radio"/> standard penetration "N", blows/ft. <input type="radio"/> moisture content, % 10 20 30 40	
	25.0						
23	23.0						
13	18.5	114.9	5.4	×	△		5.1 ○
18	18.8	110.9	5.8	×	△		5.8 ○

Water encountered at dry feet during drilling operations (W.D.).  
 Water recorded at dry feet on completion of drilling operations (A.D.).  
 Water recorded at feet hours after completion of drilling operations (A.D.).

Client: Village of Villa Park

File No. 21873 Date Drilled: 1/19/15

Reference: Geotechnical Year 1 - Group 2  
Villa Park, IL

Comments: 1044 W. Belden Ave., 5' W. of CL

Equipment:  CME 45B  CME 55  Hand Auger  Other

depth, ft	CLASSIFICATION		standard penetration	moisture content	dry unit weight lbs./cu.ft.	unconfined compressive strength	<input type="radio"/> unconfined compressive strength, tons/sq.ft. <input checked="" type="radio"/> penetrometer reading, tons/sq.ft. 1.0 2.0 3.0 4.0							
	Elevation	Existing Surface					X	Δ	⊗	○	X	Δ	○	
	(See Core Log)													
1	Black silt, some clay, trace sand & roots, damp, medium dense (topsoil) (frozen to 2.0')													
2														
3	Brown to brown-gray clay, some silt, trace sand & gravel, damp, tough to very tough		14	34.4					X		Δ			
4														
5			6	28.2	89.9	1.3	X	○		Δ				
6														
7	End of Boring		6	22.1	106.7	2.7	X			Δ	○			
8														
9														
10														

Water encountered at dry feet during drilling operations (W.D.).  
 Water recorded at dry feet on completion of drilling operations (A.D.).  
 Water recorded at feet hours after completion of drilling operations (A.D.).

Client: Village of Villa Park

File No. 21873 Date Drilled: 1/13/15

Reference: Geotechnical Year 1 - Group 2  
Villa Park, IL

Comments: 1107 W. Belden Ave., 4' S. of CL

Equipment:  CME 45B  CME 55  Hand Auger  Other

**CLASSIFICATION**  
Elevation Existing Surface

depth, ft.	(See Core Log)
1	Black silt, some clay, trace roots, damp (topsoil) (frozen to 1.5')
2	Dark brown-brown-black clay, some silt, trace sand & gravel, damp, tough
4	Brown-gray clay, some silt, trace sand & gravel, damp, very tough
5	Brown-gray clay, some silt, trace sand & gravel, damp, stiff
7	End of Boring
8	
9	
10	

standard penetration	moisture content	dry unit weight lbs./cu.ft.	unconfined compressive strength	
X	Δ	γ	○	○ unconfined compressive strength, tons/sq.ft. ● penetrometer reading, tons/sq.ft. 1.0 2.0 3.0 4.0 X standard penetration "N", blows/ft. Δ moisture content, % 10 20 30 40
28	25.4	101.1	1.0	
7	24.6	100.0	2.4	
5	30.6	93.9	0.9	

Water encountered at dry feet during drilling operations (W.D.)  
 Water recorded at dry feet on completion of drilling operations (A.D.)  
 Water recorded at feet hours after completion of drilling operations (A.D.)

Client: Village of Villa Park

File No. 21873 Date Drilled: 1/13/15

Reference: Geotechnical Year 1 - Group 2  
Villa Park, IL  
W. Belden Ave., 50' W. of  
Princeton Ave., 6' N. of CL

Comments: Equipment:  CME 45B  CME 55  Hand Auger  Other

depth, ft.	Equipment: <input checked="" type="checkbox"/> CME 45B <input type="checkbox"/> CME 55 <input type="checkbox"/> Hand Auger <input type="checkbox"/> Other	standard penetration	moisture content	dry unit weight lbs./cu.ft.	unconfined compressive strength	unconfined compressive strength, tons/sq.ft.			
	CLASSIFICATION					moisture content, %	1.0	2.0	3.0
Elevation	Existing Surface	X	Δ	⊗	○	standard penetration "N", blows/ft.			
						10	20	30	40
	(See Core Log)								
1	Black silt, some clay, trace roots, damp, medium dense (topsoil) (frozen to 2.5')								
2		19	28.2				X	Δ	
3	Dark brown-brown clay, some silt, trace sand & gravel, damp, very tough								
4									
5	Dark brown clay & silt, trace fine sand & gravel, damp	6	23.0	103.5	2.3	X		Δ	
6									
7	Dark brown clay, some silt, trace sand & gravel, damp, very tough	12	17.0	109.6	2.7	X	Δ	○	●
	End of Boring								
8									
9									
10									

Water encountered at dry feet during drilling operations (W.D.).  
 Water recorded at dry feet on completion of drilling operations (A.D.).  
 Water recorded at feet hours after completion of drilling operations (A.D.).

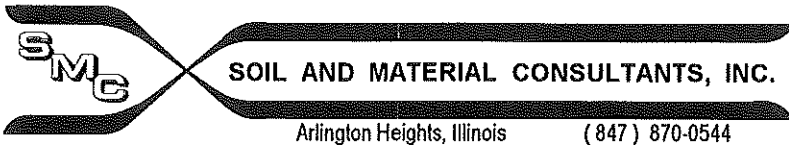

Arlington Heights, Illinois (847) 870-0544

SOIL BORING LOG 13

Logged By: DB

Page: 1 of 1

Client: Village of Villa Park

File No. 21873

Date Drilled: 1/13/15

Reference: Geotechnical Year 1 - Group 2  
Villa Park, IL

Comments: 41 W. Belden Ave., 5' S. of CL

depth, ft.	Equipment: <input checked="" type="checkbox"/> CME 45B <input type="checkbox"/> CME 55 <input type="checkbox"/> Hand Auger <input type="checkbox"/> Other	standard penetration	moisture content	dry unit weight lbs./cu.ft.	unconfined compressive strength	<input type="radio"/> unconfined compressive strength, tons/sq.ft. <input checked="" type="radio"/> penetrometer reading, tons/sq.ft. 1.0 2.0 3.0 4.0				
	CLASSIFICATION					Elevation	Existing Surface	<input checked="" type="radio"/> standard penetration "N", blows/ft. <input checked="" type="radio"/> moisture content, % 10 20 30 40		
	(See Core Log)									
1	Black silt, some clay, trace roots, damp, medium dense (topsoil) (frozen to 2.0')									
2		29	26.7							
3	Dark brown to brown-gray clay, some silt, trace sand & gravel, damp, hard									
4										
5		13	18.5	111.1	5.6		X	Δ	●	○
6										
7	End of Boring	16	18.5	114.0	5.5		X	Δ	○	5.5
8										
9										
10										

Water encountered at dry feet during drilling operations (W.D.).  
 Water recorded at dry feet on completion of drilling operations (A.D.).  
 Water recorded at feet hours after completion of drilling operations (A.D.).

Client: Village of Villa Park

File No. 21873 Date Drilled: 1/19/15

Reference: Geotechnical Year 1 - Group 2  
Villa Park, IL

Comments: 150 W. Sidney Ave., 4' N. of CL

depth, ft	Equipment: <input checked="" type="checkbox"/> CME 45B <input type="checkbox"/> CME 55 <input type="checkbox"/> Hand Auger <input type="checkbox"/> Other	standard penetration	moisture content	dry unit weight lbs./cu.ft.	unconfined compressive strength	unconfined compressive strength, tons/sq.ft.			
	CLASSIFICATION					Existing Surface	1.0	2.0	3.0
Elevation		X	Δ	⊗	○	standard penetration "N", blows/ft.			
						10	20	30	40
1	(See Core Log)								
2	Black silt, some clay, trace sand & roots, damp, medium dense (topsoil) (frozen to 2.0')	15	27.9				X	Δ	
3									
4									
5	▽	10	55.1				X		55.1 Δ
6	Dark brown-black clay, some silt, trace sand & gravel, damp, stiff		60.1	58.4	0.9				60.1 Δ
7	Gray organic silt, trace shells, very damp, soft	3	74.3				X		74.3 Δ
8	▽								
9	Gray clay, some fine sand, trace gravel, very damp, soft								
10	End of Boring	4	17.6				X	Δ	

Water encountered at 8.0 feet during drilling operations (W.D.)  
 Water recorded at 5.0 feet on completion of drilling operations (A.D.)  
 Water recorded at \_\_\_\_\_ feet \_\_\_\_\_ hours after completion of drilling operations (A.D.)

Client: Village of Villa Park

File No. 21873 Date Drilled: 1/19/15

Reference: Geotechnical Year 1 - Group 2  
Villa Park, IL  
Sidney Avenue  
Comments: 50' E. of Yale Ave., 3' N. of CL

depth, ft.	Equipment: <input checked="" type="checkbox"/> CME 45B <input type="checkbox"/> CME 55 <input type="checkbox"/> Hand Auger <input type="checkbox"/> Other	standard penetration	moisture content	dry unit weight lbs./cu.ft.	unconfined compressive strength	<input type="radio"/> unconfined compressive strength, tons/sq.ft. <input checked="" type="radio"/> penetrometer reading, tons/sq.ft. 1.0 2.0 3.0 4.0				
	CLASSIFICATION					X	Δ	X	O	X
Elevation	Existing Surface					<input checked="" type="radio"/> standard penetration "N", blows/ft. <input checked="" type="radio"/> moisture content, % 10 20 30 40				
(See Core Log)										
1	Crushed limestone with fines, damp-saturated, loose to very loose									
2										
3										
5	Gray clay, some fine sand, trace gravel, very damp, soft	5	13.1			X	Δ			
7	End of Boring	3	14.2			X	Δ			
7		3	22.4			X		Δ		
8										
9										
10										

Water encountered at 3.0 feet during drilling operations (W.D.).  
 Water recorded at 4.0 feet on completion of drilling operations (A.D.).  
 Water recorded at \_\_\_\_\_ feet \_\_\_\_\_ hours after completion of drilling operations (A.D.).

Client: Village of Villa Park

File No. 21873 Date Drilled: 1/19/15

Reference: Geotechnical Year 1 - Group 2  
Villa Park, IL  
Sidney Avenue

Comments: 235' E. of Yale Ave., 2' S. of CL

Equipment:  CME 45B  CME 55  Hand Auger  Other

**CLASSIFICATION**

Elevation Existing Surface

1	(See Core Log)
2	(4"-6" concrete slab at 1.5')
3	Black silt, some clay, trace sand & roots, damp, medium dense (topsoil)
4	Dark brown clay, some silt, trace sand & gravel, damp, tough
5	Brown-gray silt & clay, trace roots & peat, damp, loose
6	Brown-gray clay, some silt, trace sand & gravel, damp, very tough
7	End of Boring
8	
9	
10	

standard penetration	moisture content	dry unit weight lbs./cu.ft.	unconfined compressive strength	unconfined compressive strength, tons/sq.ft.	penetrometer reading, tons/sq.ft.	standard penetration "N", blows/ft.	moisture content, %
X	Δ	γ	○	○	●	X	Δ
				1.0 2.0 3.0 4.0		10 20 30 40	
13	28.0					X	Δ
7	32.9	86.1	1.7		●	X	Δ
7	22.0	105.1	2.8		●	X	Δ

Water encountered at dry feet during drilling operations (W.D.)  
 Water recorded at dry feet on completion of drilling operations (A.D.)  
 Water recorded at feet hours after completion of drilling operations (A.D.)

Client: Village of Villa Park

File No. 21873 Date Drilled: 1/19/15

Reference: Geotechnical Year 1 - Group 2  
Villa Park, IL

Comments: 1142 Yale Ave., 7' W. of CL

Equipment:  CME 45B  CME 55  Hand Auger  Other

**CLASSIFICATION**  
Elevation Existing Surface

depth, ft.	(See Core Log)
1	
2	Black silt, some clay, trace sand & roots, damp, medium dense (topsoil) (frozen to 2.0')
3	
4	Brown-gray clay, some silt, trace sand & gravel, damp, tough to very tough
5	
6	
7	End of Boring
8	
9	
10	

standard penetration	moisture content	dry unit weight lbs./cu.ft.	unconfined compressive strength	<input type="radio"/> unconfined compressive strength, tons/sq.ft. <input checked="" type="radio"/> penetrometer reading, tons/sq.ft. 1.0 2.0 3.0 4.0			
X	Δ	γ	○	<input checked="" type="checkbox"/> standard penetration "N", blows/ft. <input checked="" type="checkbox"/> moisture content, % 10 20 30 40			
14	26.2				X	Δ	
3	28.2	90.9	1.0	X	○	Δ	
8	19.9	109.3	2.5	X	Δ	○	

Water encountered at dry feet during drilling operations (W.D.).  
 Water recorded at dry feet on completion of drilling operations (A.D.).  
 Water recorded at feet hours after completion of drilling operations (A.D.).

Client: Village of Villa Park

File No. 21873

Date Drilled: 1/19/15

Reference: Geotechnical Year 1 - Group 2  
Villa Park, IL

Comments: 1115 Yake Ave., 5' E. of CL

Equipment:  CME 45B  CME 55  Hand Auger  Other

CLASSIFICATION  
Elevation Existing Surface

depth, ft.	(See Core Log)
1	Black silt, some clay, trace sand & roots, damp (topsoil) (frozen to 2.0')
2	Dark brown to brown-gray clay, some silt, trace sand & gravel, damp, very tough to hard
3	
4	
5	Dark brown to brown-gray clay, some silt, trace sand & gravel, damp, very tough
6	
7	End of Boring
8	
9	
10	

standard penetration	moisture content	dry unit weight lbs./cu.ft.	unconfined compressive strength	unconfined compressive strength, tons/sq.ft.			
X	Δ	⊗	○	1.0	2.0	3.0	4.0
				penetrometer reading, tons/sq.ft.			
				standard penetration "N", blows/ft.			
				moisture content, %			
				10	20	30	40
12	27.1	147.3	3.3	X Δ		● ○	
11	19.0	108.6	4.4	X Δ		● ○	4.4
6	22.3	106.7	2.7	X ●		Δ ○	

Water encountered at dry feet during drilling operations (W.D.).  
 Water recorded at dry feet on completion of drilling operations (A.D.).  
 Water recorded at feet hours after completion of drilling operations (A.D.).

Client: Village of Villa Park

File No. 21873 Date Drilled: 1/19/15

Reference: Geotechnical Year 1 - Group 2  
Villa Park, IL

Comments: 1043 Yale Ave., 10' W. of CL

Equipment:  CME 45B  CME 55  Hand Auger  Other

CLASSIFICATION

Elevation Existing Surface

(See Core Log)

1 Black silt, some clay, trace sand & roots, damp, very tough (topsoil)

2

Dark brown to brown-gray clay, some silt, trace sand & gravel, damp, very tough

3

Dark brown to brown-gray clay, some silt, trace sand & gravel, damp, tough to very tough

4

5

6

7

End of Boring

8

9

10

depth, ft.	standard penetration	moisture content	dry unit weight lbs./cu.ft.	unconfined compressive strength				
	X	Δ	⊗	○	○	●	X	Δ
					○	●		
1								
2		23.2						
3	16	23.8	101.6	2.6	X	Δ	○	●
4								
5	5	28.0	94.4	1.8	X	○	●	Δ
6								
7	8	22.2	105.5	2.9	X	Δ	○	●
8								
9								
10								

○ unconfined compressive strength, tons/sq.ft.  
● penetrometer reading, tons/sq.ft.  
1.0 2.0 3.0 4.0  
X standard penetration "N", blows/ft.  
Δ moisture content, %  
10 20 30 40

Water encountered at dry feet during drilling operations (W.D.).  
Water recorded at dry feet on completion of drilling operations (A.D.).  
Water recorded at feet hours after completion of drilling operations (A.D.).

Client: Village of Villa Park

File No. 21873

Date Drilled: 1/19/15

Reference: Geotechnical Year 1 - Group 2  
Villa Park, IL

Comments: 1001 Yale Ave., 5' E. of CL

Equipment:  CME 45B  CME 55  Hand Auger  Other

CLASSIFICATION

Elevation Existing Surface

(See Core Log)

1 Black silt, some clay, trace sand & roots, damp, loose (topsoil) (frozen to 2.0')

2

3 Brown-gray clay, some silt, trace sand & gravel, very damp, soft

4

5

6 Brown-gray silt, trace clay & fine sand, very damp to saturated, loose

7 End of Boring

8

9

10

depth, ft.	standard penetration	moisture content	dry unit weight lbs./cu.ft.	unconfined compressive strength	<input type="radio"/> unconfined compressive strength, tons/sq.ft. <input checked="" type="radio"/> penetrometer reading, tons/sq.ft. 1.0 2.0 3.0 4.0 <input checked="" type="radio"/> standard penetration "N", blows/ft. <input checked="" type="radio"/> moisture content, % 10 20 30 40
	X	Δ	∞	○	
1					
2					
3	6	39.7			X Δ
4					
5	3	34.2			X Δ
6					
7	5	24.9			X Δ
8					
9					
10					

Water encountered at dry feet during drilling operations (W.D.).  
 Water recorded at dry feet on completion of drilling operations (A.D.).  
 Water recorded at feet hours after completion of drilling operations (A.D.).

Client: Village of Villa Park

File No. 21873

Date Drilled: 1/19/15

Reference: Geotechnical Year 1 - Group 2  
Villa Park, IL

Comments: 951 Yale Ave., 6' W. of CL

depth, ft.	Equipment: <input checked="" type="checkbox"/> CME 45B <input type="checkbox"/> CME 55 <input type="checkbox"/> Hand Auger <input type="checkbox"/> Other	standard penetration	moisture content	dry unit weight lbs./cu.ft.	unconfined compressive strength	<input type="radio"/> unconfined compressive strength, tons/sq.ft. <input checked="" type="radio"/> penetrometer reading, tons/sq.ft. 1.0 2.0 3.0 4.0												
	CLASSIFICATION					Elevation	Existing Surface	<input checked="" type="checkbox"/> standard penetration "N", blows/ft. <input checked="" type="checkbox"/> moisture content, % 10 20 30 40										
	(See Core Log)																	
1	Dark brown-brown-gray clay, some silt, trace sand & gravel, damp (frozen to 2.0') Fill		44.1															44.1 <input checked="" type="checkbox"/>
2	Black silt, some clay, trace sand & roots, damp, dense (topsoil)	32	28.8															
3																		
4	Brown clay, some silt, trace sand, gravel & organic matter, very damp, soft																	
5	Dark brown-gray organic silt, trace shells & roots, very damp, very loose	3	67.5															67.5 <input checked="" type="checkbox"/>
6																		
7	Gray clay, some fine sand, trace gravel, damp, soft		44.9															44.9 <input checked="" type="checkbox"/>
7	End of Boring	3	22.7															
8																		
9																		
10																		

Water encountered at 6.0 feet during drilling operations (W.D.)  
 Water recorded at 3.5 feet on completion of drilling operations (A.D.)  
 Water recorded at \_\_\_\_\_ feet \_\_\_\_\_ hours after completion of drilling operations (A.D.)

Client: Village of Villa Park

File No. 21873 Date Drilled: 1/19/15

Reference: Geotechnical Year 1 - Group 2  
Villa Park, IL

Comments: 932 Yale Ave., 6' E. of CL

depth, ft.	Equipment: <input checked="" type="checkbox"/> CME 45B <input type="checkbox"/> CME 55 <input type="checkbox"/> Hand Auger <input type="checkbox"/> Other	standard penetration	moisture content	dry unit weight lbs./cu.ft.	unconfined compressive strength	<input type="radio"/> unconfined compressive strength, tons/sq.ft. <input checked="" type="radio"/> penetrometer reading, tons/sq.ft. 1.0 2.0 3.0 4.0				
	CLASSIFICATION					<input checked="" type="checkbox"/> standard penetration "N", blows/ft. <input checked="" type="checkbox"/> moisture content, %	10	20	30	40
Elevation	Existing Surface	X	Δ	⊗	○					
	(See Core Log)									
1	Dark brown-brown clay, some silt, trace sand & gravel, damp (frozen) - Fill		19.9							
2	Black silt, some clay, trace sand & roots, damp, dense (topsoil) (frozen to 2.0')	35	34.8							
3										
4	Dark brown-black clay, some silt, trace sand & gravel, very damp, stiff									
5		4	43.3							
6	Dark brown organic silt & clay, some peat, trace roots, very damp, very loose									
7	End of Boring	2	63.6							3.6 Δ
8										
9										
10										

Water encountered at dry feet during drilling operations (W.D.).  
 Water recorded at dry feet on completion of drilling operations (A.D.).  
 Water recorded at feet hours after completion of drilling operations (A.D.).

Client: Village of Villa Park

File No. 21873 Date Drilled: 1/19/15

Reference: Geotechnical Year 1 - Group 2  
 Villa Park, IL

Comments: 911 Yale Ave., 4' W. of CL

Equipment:  CME 45B  CME 55  Hand Auger  Other

**CLASSIFICATION**

Elevation Existing Surface

depth, ft.	(See Core Log)
1	Black silt, some clay, trace sand & roots, damp (topsoil) (frozen to 1.5')
2	Dark brown to brown-gray clay, some silt, trace sand & gravel, damp, very tough
3	
4	
5	
6	
7	End of Boring
8	
9	
10	

standard penetration	moisture content	dry unit weight lbs./cu.ft.	unconfined compressive strength	unconfined compressive strength, tons/sq.ft.	penetrometer reading, tons/sq.ft.	standard penetration "N", blows/ft.	moisture content, %
X	Δ	⊗	○	○	●	X	Δ
				1.0 2.0 3.0 4.0		10 20 30 40	
	25.7						
9	24.2	102.1	2.5			X	Δ ●
8	27.8	96.1	2.1			X	○ Δ ●
8	22.9	120.9	2.7			X	○ ●

Water encountered at dry feet during drilling operations (W.D).  
 Water recorded at dry feet on completion of drilling operations (A.D).  
 Water recorded at feet hours after completion of drilling operations (A.D).

Client: Village of Villa Park

File No. 21873

Date Drilled: 1/19/15

Reference: Geotechnical Year 1 - Group 2  
Villa Park, IL

Comments: 835 Yale Ave., 6' E. of CL

depth, ft	Equipment: <input checked="" type="checkbox"/> CME 45B <input type="checkbox"/> CME 55 <input type="checkbox"/> Hand Auger <input type="checkbox"/> Other	standard penetration	moisture content	dry unit weight lbs./cu.ft.	unconfined compressive strength	<input type="checkbox"/> unconfined compressive strength, tons/sq.ft. <input checked="" type="checkbox"/> penetrometer reading, tons/sq.ft. 1.0 2.0 3.0 4.0													
	CLASSIFICATION					Elevation	Existing Surface	X	Δ	⊗	○	<input checked="" type="checkbox"/> standard penetration "N", blows/ft. <input checked="" type="checkbox"/> moisture content, % 10 20 30 40							
	(See Core Log)																		
1	Brown-gray clay, some silt, trace sand & gravel, damp, very tough to hard	15	17.8	107.7	2.5														
2																			
3																			
4																			
5		16	19.4	112.9	5.0														
6																			
7	Brown fine sand, some silt, trace gravel, medium dense	12	13.2																
	End of Boring																		
8																			
9																			
10																			

Water encountered at dry feet during drilling operations (W.D.).  
 Water recorded at dry feet on completion of drilling operations (A.D.).  
 Water recorded at feet hours after completion of drilling operations (A.D.).

Client: Village of Villa Park

File No. 21873 Date Drilled: 1/19/15

Reference: Geotechnical Year 1 - Group 2  
Villa Park, IL  
Princeton Ave.  
Comments: 50' S. of Armitage Ave., 6' W. of CL

depth, ft	Equipment: <input checked="" type="checkbox"/> CME 45B <input type="checkbox"/> CME 55 <input type="checkbox"/> Hand Auger <input type="checkbox"/> Other	standard penetration	moisture content	dry unit weight lbs./cu.ft.	unconfined compressive strength	<input type="radio"/> unconfined compressive strength, tons/sq.ft. <input checked="" type="radio"/> penetrometer reading, tons/sq.ft. 1.0 2.0 3.0 4.0			
	CLASSIFICATION					<input checked="" type="radio"/> standard penetration "N", blows/ft. <input checked="" type="radio"/> moisture content, % 10 20 30 40			
Elevation	Existing Surface	X	Δ	⊗	○				
	(See Core Log)								
1	Black silt, some clay, trace sand & roots, damp (topsoil)								
2			29.5						
3	Dark brown clay, some silt, trace sand & gravel, damp, very tough	9	21.7	100.3	2.5	X	Δ	●	
4									
5	Brown-gray clay, some silt, trace sand & gravel, damp, very tough	7	20.0	109.3	2.5	X	Δ	●	○
6									
7	End of Boring	11	21.4	109.2	3.4	X	Δ	●	
8									
9									
10									

Water encountered at dry feet during drilling operations (W.D.).  
 Water recorded at dry feet on completion of drilling operations (A.D.).  
 Water recorded at feet hours after completion of drilling operations (A.D.).

Client: Village of Villa Park

File No. 21873 Date Drilled: 1/19/15

Reference: Geotechnical Year 1 - Group 2  
Villa Park, IL

Comments: 1105 Princeton Ave., 5' E. of CL

Equipment:  CME 45B  CME 55  Hand Auger  Other

**CLASSIFICATION**  
Elevation Existing Surface

(See Core Log)

1- Black silt, some clay, trace sand & roots, damp, medium dense (topsoil) (frozen to 2.5')

3- Brown to brown-gray clay, some silt, trace sand & gravel, damp, very tough

7- End of Boring

depth, ft	standard penetration	moisture content	dry unit weight lbs./cu.ft.	unconfined compressive strength
	X	Δ	⊗	○
				○ unconfined compressive strength, tons/sq.ft. ● penetrometer reading, tons/sq.ft. 1.0 2.0 3.0 4.0
				X standard penetration "N", blows/ft. Δ moisture content, % 10 20 30 40
12		27.9		X Δ
8	8	19.0	109.7	2.8 X Δ ○ ●
9	9	18.7	111.6	3.0 X Δ ● ○

Water encountered at dry feet during drilling operations (W.D.).  
Water recorded at dry feet on completion of drilling operations (A.D.).  
Water recorded at feet hours after completion of drilling operations (A.D.).

Client: Village of Villa Park

File No. 21873

Date Drilled: 1/19/15

Reference: Geotechnical Year 1 - Group 2  
Villa Park, IL

Comments: 1036 Princeton Ave., 5' W. of CL

depth, ft.	Equipment: <input checked="" type="checkbox"/> CME 45B <input type="checkbox"/> CME 55 <input type="checkbox"/> Hand Auger <input type="checkbox"/> Other	standard penetration	moisture content	dry unit weight lbs./cu.ft.	unconfined compressive strength	<input type="radio"/> unconfined compressive strength, tons/sq.ft. <input checked="" type="radio"/> penetrometer reading, tons/sq.ft. 1.0 2.0 3.0 4.0				
	CLASSIFICATION					<input checked="" type="checkbox"/> standard penetration "N", blows/ft. <input checked="" type="checkbox"/> moisture content, %	10	20	30	40
Elevation	Existing Surface	X	Δ	X	O					
	(See Core Log)									
1-	Crushed limestone with fines, damp, loose (frozen to 1.5')									
2-										
3-	▼ Black silt, some clay, trace sand & roots, damp (topsoil)	7	11.0			X	Δ			
4-										
5-	▼ Brown to brown-gray clay, some silt, trace sand & gravel, damp, soft	3	38.2			X				Δ
6-	▼ Gray organic silt, some clay, trace roots, very damp, very soft									
			44.2							X
7-	▼ Gray clay, some silt, trace sand & gravel, damp, very soft	3	14.8			X	Δ			
	End of Boring									
8-										
9-										
10-										

Water encountered at 5.5 feet during drilling operations (W.D.).  
 Water recorded at 3.0 feet on completion of drilling operations (A.D.).  
 Water recorded at \_\_\_\_\_ feet \_\_\_\_\_ hours after completion of drilling operations (A.D.).

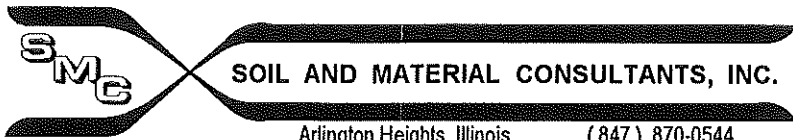

Arlington Heights, Illinois (847) 870-0544

**SOIL BORING LOG** 28

Logged By: DB Page: 1 of 1

Client: Village of Villa Park

File No. 21873 Date Drilled: 1/19/15

Reference: Geotechnical Year 1 - Group 2  
Villa Park, IL

Comments: 1022 Princeton Ave., 4' E. of CL

Equipment:  CME 45B  CME 55  Hand Auger  Other

CLASSIFICATION  
Elevation Existing Surface

depth, ft.	(See Core Log)	
	1	Black silt, some clay, trace sand & roots, damp, medium dense (topsoil) (frozen to 2.0')
2		
3	Dark brown to brown-gray clay, some silt, trace sand & gravel, damp, very tough to hard	
4		
5		
6		
7	End of Boring	
8		
9		
10		

standard penetration	moisture content	dry unit weight lbs./cu.ft.	unconfined compressive strength
X	Δ	⊗	○
12	29.9		
7	22.7	105.7	2.8
14	17.7	117.0	5.8

○ unconfined compressive strength, tons/sq.ft.  
● penetrometer reading, tons/sq.ft.  
1.0 2.0 3.0 4.0  
X standard penetration "N", blows/ft.  
Δ moisture content, %  
10 20 30 40

Water encountered at dry feet during drilling operations (W.D.).  
Water recorded at dry feet on completion of drilling operations (A.D.).  
Water recorded at feet hours after completion of drilling operations (A.D.).

Client: Village of Villa Park

File No. 21873 Date Drilled: 1/19/15

Reference: Geotechnical Year 1 - Group 2  
Villa Park, IL

Comments: 837 Princeton Ave., 5' E. of CL

Equipment:  CME 45B  CME 55  Hand Auger  Other

**CLASSIFICATION**

Elevation Existing Surface  
(See Core Log)

1	Crushed limestone with fines
2	
3	
4	
5	
6	
7	End of Boring
8	
9	
10	

standard penetration	moisture content	dry unit weight lbs./cu.ft.	unconfined compressive strength	<input type="radio"/> unconfined compressive strength, tons/sq.ft. <input checked="" type="radio"/> penetrometer reading, tons/sq.ft. 1.0 2.0 3.0 4.0	<input checked="" type="checkbox"/> standard penetration "N", blows/ft. <input checked="" type="checkbox"/> moisture content, % 10 20 30 40
X	Δ	γ	○		
	5.0				Δ
22					Δ X
10	4.6				Δ X
19	5.2				Δ X

Water encountered at dry feet during drilling operations (W.D.)  
 Water recorded at dry feet on completion of drilling operations (A.D.)  
 Water recorded at feet hours after completion of drilling operations (A.D.)

Client: Village of Villa Park

File No. 21873

Date Drilled: 1/13/15

Reference: Geotechnical Year 1 - Group 2  
Villa Park, IL

Comments: 1144 Ardmore Ave., 6' W. of CL

Equipment:  CME 45B  CME 55  Hand Auger  Other

depth, ft.	CLASSIFICATION		standard penetration	moisture content	dry unit weight lbs./cu.ft.	unconfined compressive strength	<input type="radio"/> unconfined compressive strength, tons/sq.ft. <input checked="" type="radio"/> penetrometer reading, tons/sq.ft. 1.0 2.0 3.0 4.0			
	Elevation	Existing Surface					X	Δ	⊗	○
(See Core Log)							10	20	30	40
1	Black silt, some clay, trace roots, damp (topsoil) (frozen to 2.0')									
2				33.1						
3	Dark brown to brown-gray clay, some silt, trace sand & gravel, damp, very tough		11	24.4			X	Δ		
4										
5			11	21.0	108.0	3.8	X	Δ	●	○
6										
7	End of Boring		11	20.2	110.4	3.4	X	Δ	●	○
8										
9										
10										

Water encountered at dry feet during drilling operations (W.D.).  
 Water recorded at dry feet on completion of drilling operations (A.D.).  
 Water recorded at feet hours after completion of drilling operations (A.D.).

Client: Village of Villa Park

File No. 21873 Date Drilled: 1/13/15

Reference: Geotechnical Year 1 - Group 2  
Villa Park, IL

Comments: 1128 Ardmore Ave., 7' E. of CL

depth, ft.	Equipment: <input checked="" type="checkbox"/> CME 45B <input type="checkbox"/> CME 55 <input type="checkbox"/> Hand Auger <input type="checkbox"/> Other	standard penetration	moisture content	dry unit weight lbs./cu.ft.	unconfined compressive strength	<input type="checkbox"/> unconfined compressive strength, tons/sq.ft. <input checked="" type="checkbox"/> penetrometer reading, tons/sq.ft. 1.0 2.0 3.0 4.0												
	CLASSIFICATION					Elevation	Existing Surface	<input checked="" type="checkbox"/> standard penetration "N", blows/ft. <input checked="" type="checkbox"/> moisture content, % 10 20 30 40										
	(See Core Log)																	
1	Black silt, some clay, trace roots, damp (topsoil) (frozen to 2.0')																	
2			25.9															
3	Dark brown to brown-gray clay, some silt, trace sand & gravel, damp, tough to hard	15	23.8	95.0	1.0	<input checked="" type="checkbox"/>	<input checked="" type="checkbox"/>	<input checked="" type="checkbox"/>	<input checked="" type="checkbox"/>									
4																		
5		10	18.0	108.2	3.3	<input checked="" type="checkbox"/>	<input checked="" type="checkbox"/>	<input checked="" type="checkbox"/>	<input checked="" type="checkbox"/>									
6																		
7	End of Boring	11	20.1	106.7	4.6	<input checked="" type="checkbox"/>	<input checked="" type="checkbox"/>	<input checked="" type="checkbox"/>	<input checked="" type="checkbox"/>									
8																		
9																		
10																		

Water encountered at dry feet during drilling operations (W.D.).  
 Water recorded at dry feet on completion of drilling operations (A.D.).  
 Water recorded at feet hours after completion of drilling operations (A.D.).

Logged By: DB

Page: 1 of 1

Client: Village of Villa Park

File No. 21873

Date Drilled: 1/13/15

Reference: Geotechnical Year 1 - Group 2  
Villa Park, IL

Comments: 881 Ardmore Ave., 4' W. of CL

depth, ft.	Equipment: <input checked="" type="checkbox"/> CME 45B <input type="checkbox"/> CME 55 <input type="checkbox"/> Hand Auger <input type="checkbox"/> Other	standard penetration	moisture content	dry unit weight lbs./cu.ft.	unconfined compressive strength	<input type="checkbox"/> unconfined compressive strength, tons/sq.ft. <input checked="" type="checkbox"/> penetrometer reading, tons/sq.ft. 1.0 2.0 3.0 4.0													
	CLASSIFICATION					X	Δ	∞	○	<input checked="" type="checkbox"/> standard penetration "N", blows/ft. <input checked="" type="checkbox"/> moisture content, % 10 20 30 40									
Elevation	Existing Surface	X	Δ	∞	○														
	(See Core Log)																		
1	Black silt, some clay, trace roots, damp (topsoil) (frozen to 2.0')		21.9																
2	Brown to brown-gray clay, some silt, trace sand & gravel, damp, tough	20	22.2	100.1	1.3														
3	Brown silt, some clay, trace fine sand & gravel, damp, loose																		
4																			
5		9	20.3																
6	Brown clay, some silt, trace sand & gravel, damp, hard																		
7	End of Boring	13	20.0	111.1	5.0														5.0
8																			
9																			
10																			

Water encountered at dry feet during drilling operations (W.D.).  
 Water recorded at dry feet on completion of drilling operations (A.D.).  
 Water recorded at feet hours after completion of drilling operations (A.D.).



# General Notes

## SAMPLE CLASSIFICATION

Soil sample classification is based on the Unified Soil Classification System, the Standard Practice for Description and Identification of Soils (Visual-Manual Procedure), ASTM D-2488, the Standard Test Method for Classification of Soils for Engineering Purposes, ASTM D-2487 (when applicable), and the modifiers noted below.

### CONSISTENCY OF COHESIVE SOILS

<u>Term</u>	<u>Qu -tons/sq. ft.</u>	<u>N (unreliable)</u>
Very Soft	0.00 - 0.25	0 - 2
Soft	0.26 - 0.49	3 - 4
Stiff	0.50 - 0.99	5 - 8
Tough	1.00 - 1.99	9 - 15
Very Tough	2.00 - 3.99	16 - 30
Hard	4.00 - 7.99	30 +
Very Hard	8.00 +	

### RELATIVE DENSITY OF GRANULAR SOILS

<u>Term</u>	<u>N - blows/foot</u>
Very Loose	0 - 4
Loose	5 - 9
Medium Dense	10 - 29
Dense	30 - 49
Very Dense	50 +

### IDENTIFICATION AND TERMINOLOGY

<u>Term</u>	<u>Size Range</u>
Boulder	over 8 in.
Cobble	3 in. to 8 in.
Gravel	-coarse 1 in. to 3 in.
	-medium 3/8 in. to 1 in.
	-fine #4 sieve to 3/8 in.
Sand	-coarse #10 sieve to #4 sieve
	-medium #40 sieve to #10 sieve
	-fine #200 sieve to #40 sieve
Silt	0.002 mm to #200 sieve
Clay	smaller than 0.002 mm

### Modifying Term                      Percent by Weight

Trace	1 - 10
Little	11 - 20
Some	21 - 35
And	36 - 50

### Moisture Condition

Dry  
Damp  
Very Damp  
Saturated

### DRILLING, SAMPLING & SOIL PROPERTY SYMBOLS

CF	- Continuous Flight Auger
HS	- Hollow Stem Auger
HA	- Hand Auger
RD	- Rotary Drilling
AX	- Rock Core, 1-3/16 in. diameter
BX	- Rock Core, 1-5/8 in. diameter
NX	- Rock Core, 2-1/8 in. diameter
S	- Sample Number
T	- Type of Sample
J	- Jar
AS	- Auger Sample
SS	- Split-spoon (2 in. O.D. with 1-3/8 in. I.D.)
ST	- Shelby Tube (2 in. O.D. with 1-7/8 in. I.D.)
R	- Recovery Length, in.
B	- Blows/ 6 in. interval, Standard Penetration Test (SPT)
N	- Blows/ foot to drive 2 in. O.D. split-spoon sampler with 140 lb. hammer falling 30 in., (STP)
Pen.	- Pocket Penetrometer reading, tons/ sq. ft.
W	- Water Content, % of dry weight
Uw	- Dry Unit Weight of soil, lbs./ cu. ft.
Qu	- Unconfined Compressive Strength, tons/ sq. ft.
Str	- % Strain at Qu.
WL	- Water Level
WD	- While Drilling
AD	- After Drilling
DCI	- Dry Cave-in
WCI	- Wet Cave-in
LL	- Liquid Limit, %
PL	- Plastic limit, %
PI	- Plasticity Index (LL-PL)
LI	- Liquidity Index [(W-PL)/PI]

NOT FOR BID

# Geotechnical Engineering Report

**Pavement Evaluation**

**Multiple Streets**

**Villa Park, Illinois**

March 16, 2015

Terracon Project No. MR155009

**Prepared for:**

Village of Villa Park  
Villa Park, Illinois

**Prepared by:**

Terracon Consultants, Inc.  
Naperville, Illinois

[terracon.com](http://terracon.com)

**Terracon**

Environmental



Facilities



Geotechnical



Materials

NOT FOR BID

March 16, 2015



Village of Villa Park  
20 South Ardmore Avenue  
Villa Park, Illinois 60181

Attention: Mr. Kevin Mantels, E.I.T.  
Senior Engineering Assistant

Re: Geotechnical Engineering Report  
Pavement Evaluation  
Multiple Streets  
Villa Park, Illinois  
Terracon Project No. MR155009

Dear Mr. Mantels:

Terracon Consultants, Inc. (Terracon) has completed the geotechnical engineering services for the above referenced project. This report presents the findings of the subsurface exploration and provides geotechnical recommendations concerning the pavements at the site.

We appreciate the opportunity to be of service to you on this project. If you have any questions concerning this report, or if we may be of further service, please contact us.

Sincerely,  
**Terracon Consultants, Inc.**

A handwritten signature in blue ink, appearing to read "Madhu R. Karri".

Madhu R. Karri, P.E.  
Project Engineer

A handwritten signature in blue ink, appearing to read "Kole C. Berg".

Kole C. Berg, P.E.  
Illinois No. 062-060554  
Renews 11-30-2015



Terracon Consultants, Inc. 135 Ambassador Drive Naperville, Illinois 60540  
P [630] 717 4263 F [630] 357 9489 terracon.com

Geotechnical



Environmental



Construction Materials



Facilities

NOT FOR BID

## TABLE OF CONTENTS

	Page
<b>EXECUTIVE SUMMARY</b> .....	i
<b>1.0 INTRODUCTION</b> .....	1
<b>2.0 PROJECT INFORMATION</b> .....	1
2.1 Project Description .....	1
2.2 Site Location and Description .....	2
<b>3.0 SUBSURFACE CONDITIONS</b> .....	3
3.1 Typical Profile .....	3
3.2 Water Level Observations .....	3
3.3 Existing Pavement Condition .....	4
3.4 Pavement Core Thickness Summary .....	5
<b>4.0 RECOMMENDATIONS FOR DESIGN AND CONSTRUCTION</b> .....	6
4.1 Geotechnical Considerations .....	6
4.2 Pavement Thickness Recommendations.....	7
4.2.1 Design Recommendations .....	8
4.2.2 Construction Recommendations .....	10
4.3 Earthwork.....	10
4.3.1 Compaction Requirements .....	11
4.3.2 Construction Considerations .....	11
<b>5.0 GENERAL COMMENTS</b> .....	12
 <b>APPENDIX A – FIELD EXPLORATION</b>	
Exhibit A-1	Field Exploration Description
Exhibit A-2	Boring Location Diagram
Exhibits A-3 to A-34	Boring Logs
 <b>APPENDIX B – LABORATORY TESTING</b>	
Exhibit B-1	Laboratory Testing
 <b>APPENDIX C – SUPPORTING DOCUMENTS</b>	
Exhibit C-1	General Notes
Exhibit C-2	Unified Soil Classification

NOT FOR BID

## **EXECUTIVE SUMMARY**

Terracon has completed a geotechnical study for the proposed rehabilitation of the pavements along the alignments of several existing streets in Villa Park, Illinois. Thirty-two (32) borings were drilled in the subject areas to depths of approximately 7½ feet below the existing pavement surface. Based on the information obtained from our subsurface exploration, the following geotechnical considerations were identified:

- The existing pavements encountered at the boring locations consisted of asphaltic cement concrete (ACC) or Portland cement concrete sections (PCC). In general, both the ACC and PCC pavements exhibited varying types of distress and moderate to high severity degrees of deterioration. Typical distress types include longitudinal and transverse cracking, raveling of the surface, depressions/rutting in wheel paths, alligator cracking, joint cracking, edge cracking, corner cracking, diagonal cracking, and potholes. Pavement patching was also observed in some areas. Some of the concrete joints appeared to have been patched with asphalt cold patch compound.
- In general, the pavement distress appeared to be related to the age and traffic conditions. Some of the distress could also be related to the lack of proper maintenance over the age of the pavement. Due to the severely distressed condition of the existing pavements, we recommend that pavement rehabilitation should consist of removing existing pavement and crushed stone and replacing with the recommended thicknesses of asphalt/concrete and crushed stone aggregate. Alternately, in ACC-paved areas where low to moderate severity distress was observed, consideration could be given to milling at least 2 inches of existing asphalt and overlaying in order to extend the life of the pavement for 5 to 7 years.
- In general, the existing asphalt pavement sections consisted of approximately 3 to 6 inches of ACC over up to 8 inches of crushed stone aggregate. Similarly, the existing concrete pavement sections consisted of approximately 5 to 9½ inches of PCC over up to about 9 inches of crushed stone aggregate. Below the pavements in the borings, existing fill comprised primarily of lean clay or sandy gravel with varying amounts of silt, sand, and organics was present in twelve (12) of the thirty-two borings to depths of about 3 to 7½ feet below existing grade. Below the fill, native soils consisting predominately of medium stiff to very stiff lean clay or lean to fat clay with variable amounts of sand, gravel, and organics were encountered to the boring termination depths of about 7½ feet.
- Clay soils with relatively high moisture contents (about 21 to 49 percent) were encountered in the upper few feet of the soil profile at most of the boring locations. At some locations, the subgrade soils below the existing pavements appeared to contain a significant amount of organics (possible buried topsoil). Subgrades comprised of these soils can become unstable when they are disturbed and/or subjected to construction

## Geotechnical Engineering Report

Pavement Evaluation ■ Multiple Streets, Villa Park, Illinois  
March 16, 2015 ■ Terracon Project No. MR155009



traffic. Therefore, some undercutting or stabilization of the subgrade may be required to facilitate compaction of new engineered fill and/or to provide a stable subgrade for floor slabs and pavements. In addition, the modified Proctor optimum moisture content for these soils typically ranges from about 11 to 14 percent. Therefore, significant drying of the on-site soils will likely be required before they can be properly compacted to develop a suitable subgrade for the new pavements.

- The subgrade soils should be observed and tested by proofrolling to evaluate the suitability of the materials (native and fill) for support of pavements. Unsuitable areas should be improved by compaction or be removed and replaced with engineered fill.

This summary should be used in conjunction with the entire report for design purposes. It should be recognized that details were not included or fully developed in this section, and the report must be read in its entirety for a comprehensive understanding of the items contained herein. The section titled **GENERAL COMMENTS** should be read for an understanding of the report limitations.

**GEOTECHNICAL ENGINEERING REPORT**  
**PAVEMENT EVALUATION**  
**MULTIPLE STREETS**  
**VILLA PARK, ILLINOIS**  
Terracon Project No. MR155009  
March 16, 2015

## **1.0 INTRODUCTION**

Terracon Consultants, Inc. (Terracon) has completed a subsurface exploration for the proposed rehabilitation of the pavements along the existing streets in Villa Park, Illinois. Thirty-two (32) borings were performed to depths of about 7½ feet below existing grades. This report presents the following information:

- subsurface soil conditions encountered at the boring locations,
- recommendations for pavement thickness design and construction, and
- earthwork recommendations for pavement subgrades.

Boring logs and a Boring Location Diagram are included in Appendix A. The results of the laboratory testing performed on soil samples obtained from the borings are included on the boring logs in Appendix A. Descriptions of the field exploration and laboratory testing are included in their respective appendices.

## **2.0 PROJECT INFORMATION**

### **2.1 Project Description**

We understand that the Village of Villa Park is considering rehabilitation plans for several existing streets. Based on the information provided, the following table summarizes the individual streets considered for improvements and the number of borings along them.

## Geotechnical Engineering Report

Pavement Evaluation ■ Multiple Streets, Villa Park, Illinois  
March 16, 2015 ■ Terracon Project No. MR155009



STREET	FROM	TO	LENGTH (Approx., in feet)	SURFACE/ BASE TYPE	NUMBER OF BORINGS
Illinois Avenue	North End	Maple Street	129	ACC	1
	Maple Street	Division Street	569	ACC	2
Ridge Road	Westmore Avenue	Biermann Avenue	325	PCC	2
	Biermann Avenue	Second Avenue	325	PCC	1
	Second Avenue	Third Avenue	327	PCC	1
	Third Avenue	Addison Road	350	PCC	1
Stone Road	Addison Road	Iowa Avenue	352	PCC	2
	Iowa Avenue	Wisconsin Avenue	338	PCC	1
	Wisconsin Avenue	Michigan Avenue	349	ACC	1
	North Avenue	Third Avenue	422	PCC	2
	Third Avenue	Addison Road	374	PCC	1
Sunset Drive	Yale Avenue	Harvard Avenue	440	PCC	2
	Harvard Avenue	Michigan Avenue	328	PCC	1
	Michigan Avenue	Wisconsin Avenue	329	PCC	1
	Wisconsin Avenue	Iowa Avenue	330	PCC	1
	Iowa Avenue	Addison Road	337	PCC	1
Terrace Street	Ardmore Avenue	Princeton Avenue	410	PCC	2
	Princeton Avenue	Yale Avenue	447	PCC	1
Wisconsin Avenue	Stone Road	Ridge Road	361	PCC	2
	Ridge Road	Sunset Drive	520	ACC	2
	Sunset Drive	Plymouth Street	667	ACC	2
	Plymouth Street	Vermont Street	616	ACC	2
<b>Total</b>			<b>8645</b>		<b>32</b>

## 2.2 Site Location and Description

ITEM	DESCRIPTION
Location	Various streets in Villa Park, Illinois.
Current Site Improvements	Existing streets paved with asphalt or concrete.

### 3.0 SUBSURFACE CONDITIONS

#### 3.1 Typical Profile

Subsurface conditions at each boring location are described on the individual boring logs in Appendix A. The stratification boundaries shown on the boring logs represent the approximate depths where changes in material types occur. In-situ, transitions between material types can be more gradual. Based on the results of the borings, subsurface conditions on the project site can be generalized as follows:

Description	Approximate Depth to Bottom of Stratum	Material Encountered	Consistency/Density
Surface	6½ to 17½ inches	About 3 to 6 inches of ACC over up to 8 inches of crushed stone aggregate or approximately 5 to 9½ inches of PCC over up to about 9 inches of crushed stone aggregate	N/A
Stratum 1 <sup>1</sup>	3 to 7½ feet	Existing fill: Lean clay, lean to fat clay, sandy gravel, with varying amounts of silt, sand, and organics	N/A
Stratum 2	Undetermined; stratum continued to boring termination depths of about 7½ feet	Native soils: Lean clay or lean to fat clay with varying amounts of sand, silt, and organics	Medium stiff to very stiff

#### 3.2 Water Level Observations

The borings were observed during and after the completion of drilling for the presence and level of water. Water was not observed in the borings at these times. The absence of water at a boring location does not necessarily mean that the boring terminated above the subsurface water level. Due to the relatively low permeability of the clay soils encountered in the borings, longer term observations in cased holes or piezometers, sealed from the influence of surface water, would be required for a better evaluation of the groundwater conditions on this site.

Water levels may fluctuate due to seasonal variations in the amount of rainfall, runoff, and other factors not evident at the time the borings were performed. Trapped water could occur within aggregate base layers, existing fill materials, and perched water could occur above lower permeability soil layers. Subsurface water levels during construction or at other times in the future may be different from the levels indicated on the boring logs. Water level fluctuations and

perched water should be considered when developing design and construction plans and specifications for the project.

### 3.3 Existing Pavement Condition

Most of the observed pavement distress consisted of moderate to high severity cracking. We generally observed a total of six (6) types of asphalt pavement distress. The following presents a brief description of each of these distress types observed at the sites:

- **Alligator Cracking:** Alligator cracking (a structural distress) is usually the result of loss of support for the pavement through a reduction in the strength of the subgrade soils. However, alligator cracking can also be caused as a result of load-related failure from traffic due to inadequate pavement thickness, especially in heavy duty traffic areas. Without proper maintenance or rehabilitation, alligator cracking usually becomes more severe. The on-set of alligator cracking was observed at several locations of the existing streets. The alligator cracking is at moderate to high severity at most of the locations. In general, the presence of alligator cracking indicates a significant loss of pavement life.
- **Depression:** Depressions are localized pavement surface areas with elevations slightly lower than those of the surrounding pavement. In many instances, light depressions are not noticeable until after a rain when ponding water creates a “bird bath” area. On dry pavement, depressions can be spotted by stains caused by ponding water. Depressions are created by settlement of the foundation soils or a result of improper construction practices. Depressions cause some roughness in the pavement surface. Depressions, resulting in ponding water and weathering were observed at several locations.
- **Longitudinal and Transverse Cracking:** Longitudinal and transverse cracking is generally associated with pavement joints and traffic corridors. It is usually the result of climate or pavement durability related factors. Without proper maintenance or rehabilitation, this type of cracking can progress to more severe forms of pavement distress including block or alligator cracking. Longitudinal and transverse cracking were observed throughout the entire paved areas at low to high severity.
- **Patching:** A patch is an area of pavement which has been placed with new materials to repair the existing pavement. A patch is considered a defect no matter how well it is performing (a patched area or adjacent area does not usually perform as well as an original pavement section). Generally some roughness is always associated with this type of distress. Patching was observed in a few areas.
- **Potholes:** A pothole is a small, usually less than 2½ feet in diameter, bowl shaped depression in the pavement surface. The perimeter edge is sharp and vertical near the top. Potholes were observed in several areas.
- **Weathering and Raveling:** Weathering and raveling are caused by the loss of asphalt binder and dislodged aggregate particles in the pavement surface from climate and

## Geotechnical Engineering Report

Pavement Evaluation ■ Multiple Streets, Villa Park, Illinois  
March 16, 2015 ■ Terracon Project No. MR155009



pavement durability related factors. When left untreated, weathering will eventually result in the dislodging (raveling) of aggregate particles in the pavement surface. Occasional weathering and oxidation were observed.

### 3.4 Pavement Core Thickness Summary

STREET	FROM	TO	BORING/ CORE NUMBER	SURFACE TYPE	THICKNESS OF PAVEMENT (INCHES)	THICKNESS OF AGGREGATE (INCHES)
Illinois Avenue	North End	Maple Street	1	ACC	4.5	8
	Maple Street	Division Street	2	ACC	4.5	8
	Maple Street	Division Street	3	ACC	4	8
Terrace Street	Ardmore Avenue	Princeton Avenue	4	PCC	7	5
	Ardmore Avenue	Princeton Avenue	5	PCC	9.5	-
	Princeton Avenue	Yale Avenue	6	PCC	7.5	-
Sunset Drive	Yale Avenue	Harvard Avenue	7	PCC	6.5	-
	Yale Avenue	Harvard Avenue	8	PCC	5	5
	Harvard Avenue	Michigan Avenue	9	PCC	6	2
	Michigan Avenue	Wisconsin Avenue	10	PCC	6.5	3
	Wisconsin Avenue	Iowa Avenue	11	PCC	6	3
	Iowa Avenue	Addison Road	12	PCC	6	3
Wisconsin Avenue	Plymouth Street	Vermont Street	13	ACC	3.5	6
	Plymouth Street	Vermont Street	14	ACC	6	6
	Sunset Drive	Plymouth Street	15	ACC	5	8
	Sunset Drive	Plymouth Street	16	ACC	4	6
	Ridge Road	Sunset Drive	17	ACC	4	7
	Ridge Road	Sunset Drive	18	ACC	4.5	6
	Stone Road	Ridge Road	19	PCC	8.5	9
	Stone Road	Ridge Road	20	PCC	7.5	3
Stone Road	Wisconsin Avenue	Michigan Avenue	21	ACC	3	8
	Iowa Avenue	Wisconsin Avenue	22	PCC	8.5	3
	Addison Road	Iowa Avenue	23	PCC	7.5	3
	Addison Road	Iowa Avenue	24	PCC	9	5
	North Avenue	Third Avenue	25	PCC	8	4
	North Avenue	Third Avenue	26	PCC	8	6
	Third Avenue	Addison Road	27	PCC	8	6
Ridge Road	Third Avenue	Addison Road	28	PCC	6.5	5
	Second Avenue	Third Avenue	29	PCC	7	5
	Biermann Avenue	Second Avenue	30	PCC	6.5	-
	Biermann Avenue	Second Avenue	31	PCC	6.5	5
	Westmore Avenue	Biermann Avenue	32	PCC	6.5	6

## **4.0 RECOMMENDATIONS FOR DESIGN AND CONSTRUCTION**

### **4.1 Geotechnical Considerations**

The existing pavements encountered at the boring locations consisted of asphaltic cement concrete (ACC) or Portland cement concrete sections (PCC). In general, both the ACC and PCC pavements exhibited varying types of distress and moderate to high severity degrees of deterioration. Typical distress types include longitudinal and transverse cracking, raveling of the surface, depressions/rutting in wheel paths, alligator cracking, joint cracking, edge cracking, corner cracking, diagonal cracking, and potholes. Pavement patching was also observed in some areas. Some of the concrete joints appeared to have been patched with asphalt cold patch compound.

In general, the pavement distress appeared to be related to the age and traffic conditions. Some of the distress could also be related to the lack of proper maintenance over the age of the pavement. Due to the severely distressed condition of the existing pavements, we recommend that pavement rehabilitation should consist of removing existing pavement and crushed stone and replacing with the recommended thicknesses of asphalt/concrete and crushed stone aggregate. Alternately, in ACC-paved areas where low to moderate severity distress was observed, consideration could be given to milling at least 2 inches of existing asphalt and overlaying in order to extend the life of the pavement for 5 to 7 years.

In general, the existing asphalt pavement sections consisted of approximately 3 to 6 inches of ACC over up to 8 inches of crushed stone aggregate. Similarly, the existing concrete pavement sections consisted of approximately 5 to 9½ inches of PCC over up to about 9 inches of crushed stone aggregate. Below the pavements in the borings, existing fill comprised primarily of lean clay or sandy gravel with varying amounts of silt, sand, and organics was present in twelve (12) of the thirty-two borings to depths of about 3 to 7½ feet below existing grade. Below the fill, native soils consisting predominately of medium stiff to very stiff lean clay or lean to fat clay with variable amounts of sand, gravel, and organics were encountered to the boring termination depths of about 7½ feet.

Clay soils with relatively high moisture contents (about 21 to 49 percent) were encountered in the upper few feet of the soil profile at most of the boring locations. At some locations, the subgrade soils below the existing pavements appeared to contain a significant amount of organics (possible buried topsoil). Subgrades comprised of these soils can become unstable when they are disturbed and/or subjected to construction traffic. Therefore, some undercutting or stabilization of the subgrade may be required to facilitate compaction of new engineered fill and/or to provide a stable subgrade for floor slabs and pavements. In addition, the modified Proctor optimum moisture content for these soils typically ranges from about 11 to 14 percent.

## Geotechnical Engineering Report

Pavement Evaluation ■ Multiple Streets, Villa Park, Illinois  
 March 16, 2015 ■ Terracon Project No. MR155009



Therefore, significant drying of the on-site soils will likely be required before they can be properly compacted to develop a suitable subgrade for the new pavements.

The subgrade soils should be observed and tested by proofrolling to evaluate the suitability of the materials (native and fill) for support of pavements. Unsuitable areas should be improved by compaction or be removed and replaced with engineered fill.

### 4.2 Pavement Thickness Recommendations

Location	Existing Pavement Thicknesses (Average)		Recommended Standard Pavement Thicknesses (Minimum)		Recommended Rehabilitation Method
	Asphalt/Concrete (inches)	Crushed Stone Aggregate (inches)	Asphalt/Concrete (inches)	Crushed Stone Aggregate (inches)	
Illinois Avenue	4.5	8	5 (ACC)	10	Milling and overlaying with complete removal and replacement in selected areas
Terrace Street	8	5	8 (PCC)	4	Complete removal and replacement
Sunset Drive	6	3	8 (PCC)	4	Complete removal and replacement
Wisconsin Avenue (Plymouth Street to Vermont Street)	4.5	6	8 (PCC)	4	Complete removal and replacement
Wisconsin Avenue (Ridge Road to Plymouth Street)	4.5	7	5 (ACC)	10	Milling and overlaying with complete removal and replacement in selected areas
Wisconsin Avenue (Stone Road to Ridge Road)	8	6	8 (PCC)	4	Complete removal and replacement
Stone Road (Wisconsin Avenue to Michigan Avenue)	3	8	5 (ACC)	10	Milling and overlaying with complete removal and replacement in selected areas

## Geotechnical Engineering Report

Pavement Evaluation ■ Multiple Streets, Villa Park, Illinois  
March 16, 2015 ■ Terracon Project No. MR155009



Location	Existing Pavement Thicknesses (Average)		Recommended Standard Pavement Thicknesses (Minimum)		Recommended Rehabilitation Method
	Asphalt/Concrete (inches)	Crushed Stone Aggregate (inches)	Asphalt/Concrete (inches)	Crushed Stone Aggregate (inches)	
Stone Road (PCC sections)	8	4.5	8 (PCC)	4	Complete removal and replacement
Ridge Road (PCC sections)	6.5	5	8 (PCC)	4	Complete removal and replacement

Pavement thickness design is dependent upon:

- The anticipated traffic conditions,
- Subgrade and paving material characteristics, and
- Climate conditions at the project site.

Specific information regarding anticipated vehicle types and traffic volumes was not provided. In developing our recommendations, we have considered that traffic will consist primarily of automobile traffic and a limited number of buses and trash collection trucks. If heavier vehicles or higher traffic volumes are expected, Terracon should be notified and these recommendations should be reviewed.

We understand that existing site grades will essentially remain the same and little or no grading will be performed for this project, except for undercutting to develop the recommended pavement section and undercutting to remove any soft soils exposed at subgrade level. Complete removal and replacement of new pavement sections is recommended in areas where moderate to high severity pavement distress was observed. ACC-paved areas where low to moderate severity distress was observed, consideration could be given to milling and overlaying a portion of the existing asphalt pavement in order to extend the life of the asphalt pavements for a period of 5 to 7 years. Further recommendations are provided below.

### 4.2.1 Design Recommendations

#### Mill and Overlay

Based on the information obtained from our field visit, our soil borings, and our analysis, a pavement section with 2-inch mill and overlay of asphalt concrete will extend the useable life of the ACC-paved areas with low to moderate severity distress for a design period of about 5 to 7 years.

**Removal and Replacement**

Estimated minimum pavement sections for parking areas and drive areas are provided in the following table.

<b>ACC Pavements</b>				
<b>Pavement Area</b>	<b>Estimated Minimum Pavement Sections (inches) <sup>1</sup></b>			
	<b>ACC Surface</b>	<b>ACC Binder</b>	<b>Aggregate Base Course <sup>2</sup></b>	<b>Total</b>
Asphalt Pavements	2	3	10	15
Concrete Pavements	8 inches PCC		4	11

1. Portland cement concrete pavements are recommended for areas subject to heavy static loads.

2. IDOT CA-6 or an approved alternate gradation.

2" Hot Mix Asphalt Surface Course, IL-12.5 surface

3" Hot Mix Asphalt Binder Course, IL-19.0 binder

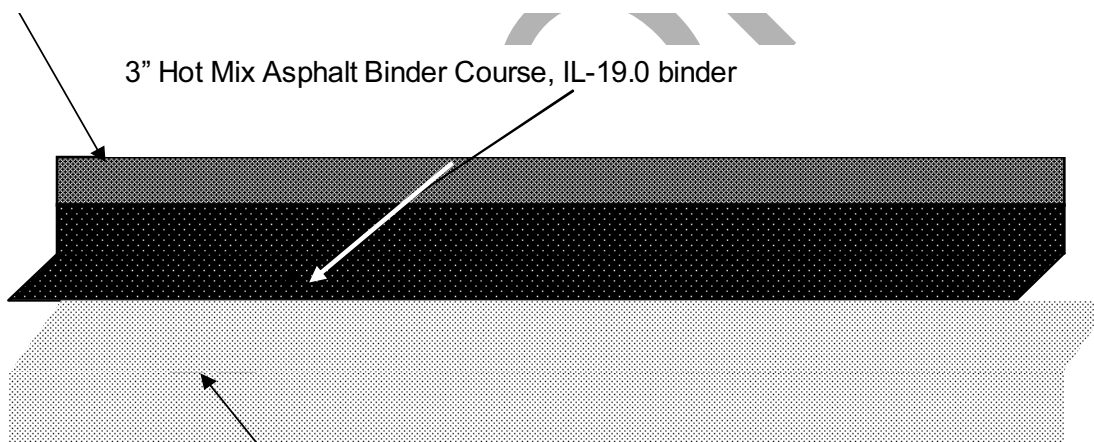

10" Aggregate Base Course material, IDOT CA-6

All paving materials should meet the requirements of the Illinois Department of Transportation (IDOT) Standard Specifications for Road and Bridge Construction, 2007 edition (Section 1000). Concrete pavement should be air-entrained and have a minimum compressive strength of 4,000 psi after 28 days of laboratory curing (ASTM C 31). Aggregate base course materials should conform to Section 1004, Coarse Aggregates, gradation CA-6.

PCC pavements should be designed with longitudinal and transverse joints spaced no more than 15 feet apart. Control joints should be saw-cut at least 1/4 of the depth of the concrete section, and should be cut within the appropriate timeframe (usually within 12 to 24 hours,

depending on the concrete mix properties and conditions at the time of placement). Expansion (isolation) joints must be full depth and should only be used to isolate fixed objects abutting or within the paved area.

**4.2.2 Construction Recommendations**

The existing crushed stone base material appears to be suitable for re-use as stone base beneath the new pavement sections. Additional material should be budgeted as contingency for any contaminated or otherwise unsuitable material that will have to be disposed off the site and replaced with new imported materials.

We recommend that the aggregate base course be compacted to at least 95 percent of its maximum dry density as determined by ASTM D 1557. We also recommend that an engineering technician be present during placement of the base to verify that the compaction criteria are met and to aid in the evaluation of the placement and compaction techniques.

**4.3 Earthwork**

Where removal and replacement of the existing pavement section is planned, upon removal of the existing pavement and stone base and cutting to subgrade level, proofrolling with heavy construction equipment such as a loaded scraper or tandem axle dump truck is recommended to help locate unstable subgrade materials. Unstable materials located by proofrolling should be removed and replaced with suitable compacted fill material outlined in the following table.

Fill Type <sup>1</sup>	USCS Classification	Acceptable Location for Placement
Lean clay	CL (LL<40, PI<22)	All locations and elevations
Lean to fat clay	CL/CH (40<LL<50, PI≤25)	> 1.5 ft. below pavement finished subgrade unless tested and meets low volume change material criteria
Fat clay	CH (LL >50, PI>25)	Not recommended
Well graded granular	GW <sup>3</sup>	All locations and elevations

1. Controlled, compacted fill should consist of approved materials that are free of organic matter and debris. Frozen material should not be used, and fill should not be placed on a frozen subgrade. A sample of each material type should be submitted to the geotechnical engineer for evaluation.
2. IDOT CA-6 crushed limestone aggregate or an approved equivalent gradation.

### 4.3.1 Compaction Requirements

ITEM	DESCRIPTION
Fill Lift Thickness	9 inches or less in loose thickness
Compaction Requirements <sup>1</sup>	95% of the material's maximum modified Proctor dry density (ASTM D 1557)
Moisture Content Cohesive Soil	Within the range of $\pm 2\%$ of modified Proctor optimum moisture content at the time of placement and compaction
Moisture Content Granular Material <sup>2</sup>	Workable moisture levels, generally $\pm 2\%$ of optimum

1. We recommend that engineered fill be tested for moisture content and compaction during placement. Should the results of the in-place density tests indicate the specified moisture or compaction limits have not been met, the area represented by the test should be reworked and retested as required until the specified moisture and compaction requirements are achieved.
2. Specifically, moisture levels should be maintained low enough to allow for satisfactory compaction to be achieved without the granular fill material pumping when proofrolled.

### 4.3.2 Construction Considerations

Compaction equipment and techniques will be dependent on the size of the area and type of material being used as fill. For larger removal/replacement areas, it may be possible to use a sheepfoot roller to compact existing subgrade soils and a large vibratory drum roller to compact the aggregate base materials. In localized/confined areas, a jumping jack or smaller vibratory drum roller may be required to compact new fill/base course materials.

Clay soils with high moisture contents (about 21 to 49 percent) were encountered within the upper few feet of the soil profile at most of the boring locations. At some locations, the subgrade soils below the existing pavements appeared to contain a significant amount of organics (possible buried topsoil). These soils will be sensitive to disturbance from construction activities, particularly if further wetted by surface water or seepage. Therefore, it is anticipated that some areas of the site may become unstable during proofrolling and construction operations. The amount of stabilization required would be highly dependent upon weather conditions during construction and drainage measures implemented during mass grading and construction.

Subgrade stabilization may be required in some areas of the site to facilitate construction, particularly if wet soils are encountered in cut areas or if significant precipitation occurs prior to or during site grading operations. In general (weather permitting), scarifying, drying and recompacting the exposed subgrades is expected to be the most economical means of improving these soils prior to placing new fill. However, this option is typically less effective where soft/wet soils are thicker than about one foot, and this method is also dependent on weather conditions. Alternatives for subgrade stabilization could include undercutting unsuitable (wet, low strength, and/or disturbed) soils followed by the addition of crushed stone aggregate (typically on the order of 12 to 18 inches) to improve subgrade stability, or the incorporation of a chemical additive such as lime, Class C fly ash or portland cement. A geosynthetic (i.e., a geogrid or high-modulus

## Geotechnical Engineering Report

Pavement Evaluation ■ Multiple Streets, Villa Park, Illinois  
March 16, 2015 ■ Terracon Project No. MR155009



geotextile) overlain with crushed stone could be used in some areas to reduce undercut depths and to develop stable subgrades for fill placement or new construction. The need for stabilization and most appropriate type of stabilization will be dependent upon soil, groundwater and weather conditions, as well as the proposed grading plan, the construction schedule and methods of construction that will be used. Terracon should be retained during construction to help provide recommendations as needed.

If seepage is encountered in excavations, the contractor is responsible for employing appropriate dewatering methods to control seepage and facilitate construction. Seepage into excavations in cohesive soils can typically be controlled using sump pits and pumps from within the excavations. Groundwater levels should be maintained at least 2 feet below the maximum anticipated excavation level.

Upon completion of subgrade preparation, care should be taken to maintain the subgrade moisture content prior to pavement construction. Construction traffic over the completed subgrade should be avoided to the extent practical. If the subgrade should become desiccated, saturated, or disturbed, the affected material should be removed; or where suitable, scarified, moisture conditioned, and recompacted prior to pavement construction.

## 5.0 GENERAL COMMENTS

We recommend the geotechnical engineer be retained to review the final design plans and specifications so comments can be made regarding interpretation and implementation of our geotechnical recommendations in the design and specifications. We further recommend that a qualified geotechnical engineering firm be retained for observation and testing services during grading, excavation, pavement construction and other earth-related construction phases of the project.

Support of the pavements on/above existing fill is discussed in this report. Even with the construction observation/testing recommended in this report, a risk remains for the owner that unsuitable materials within or buried by the fill will not be discovered. This may result in larger than normal settlement and damage to the pavements, requiring additional maintenance. This risk can be reduced (but not eliminated) by thorough observation and testing as discussed herein.

The analysis and recommendations presented in this report are based upon the data obtained from the borings performed at the indicated locations and from other information discussed in this report. This report does not reflect variations that may occur between borings, across the site, or due to the modifying effects of construction or weather. The nature and extent of such variations may not become evident until during or after construction. If variations appear, we

## Geotechnical Engineering Report

Pavement Evaluation ■ Multiple Streets, Villa Park, Illinois  
March 16, 2015 ■ Terracon Project No. MR155009



should be immediately notified so that further evaluation and supplemental recommendations can be provided.

The scope of services for this project does not include either specifically or by implication any environmental or biological (e.g., mold, fungi, bacteria) assessment of the site or identification or prevention of pollutants, hazardous materials or conditions. If the owner is concerned about the potential for such contamination or pollution, other studies should be undertaken.

This report has been prepared for the exclusive use of our client for specific application to the project discussed and has been prepared in accordance with generally accepted geotechnical engineering practices. No warranties, either express or implied, are intended or made. Site safety, excavation support, and dewatering requirements are the responsibility of others. In the event that changes in the nature, design, or location of the project as outlined in this report are planned, the conclusions and recommendations contained in this report shall not be considered valid unless Terracon reviews the changes and either verifies or modifies the conclusions of this report in writing.

NOT FOR CONSTRUCTION

NOT FOR BID

NOT FOR BID

**APPENDIX A**  
**FIELD EXPLORATION**

NOT FOR BID

## Geotechnical Engineering Report

Pavement Evaluation ■ Multiple Streets, Villa Park, Illinois  
March 16, 2015 ■ Terracon Project No. MR155009



### Field Exploration Description

The borings were drilled at the approximate locations indicated on the attached Boring Location Diagram (Exhibit A-2). The boring locations were located in the field by a Terracon representative who located the borings using existing site features and landmarks. Surface elevations at the boring locations were not provided. The locations of the borings should be considered accurate only to the degree implied by the means and methods used to define them.

Cores of the existing pavements were obtained at the boring locations. The borings were performed with a truck-mounted, rotary drill rig using continuous flight hollow-stemmed augers to advance the boreholes. Soil samples were obtained using split-barrel sampling procedures, in which a standard 2-inch (outside diameter) split-barrel sampling spoon is driven into the ground with a 140-pound automatic hammer falling a distance of 30 inches. The number of blows required to advance the sampling spoon the last 12 inches (or less) of a normal 18-inch penetration is recorded as the Standard Penetration Test (SPT) resistance value. These values are provided on the boring logs at the depths of occurrence. The samples were sealed and transported to the laboratory for testing and classification.

The drill crew prepared a field log of each boring. These logs included visual classifications of the materials encountered during drilling and the driller's interpretation of the subsurface conditions between samples. The boring logs included with this report represent the engineer's interpretation of the field logs and include modifications based on laboratory observation and tests of the samples.

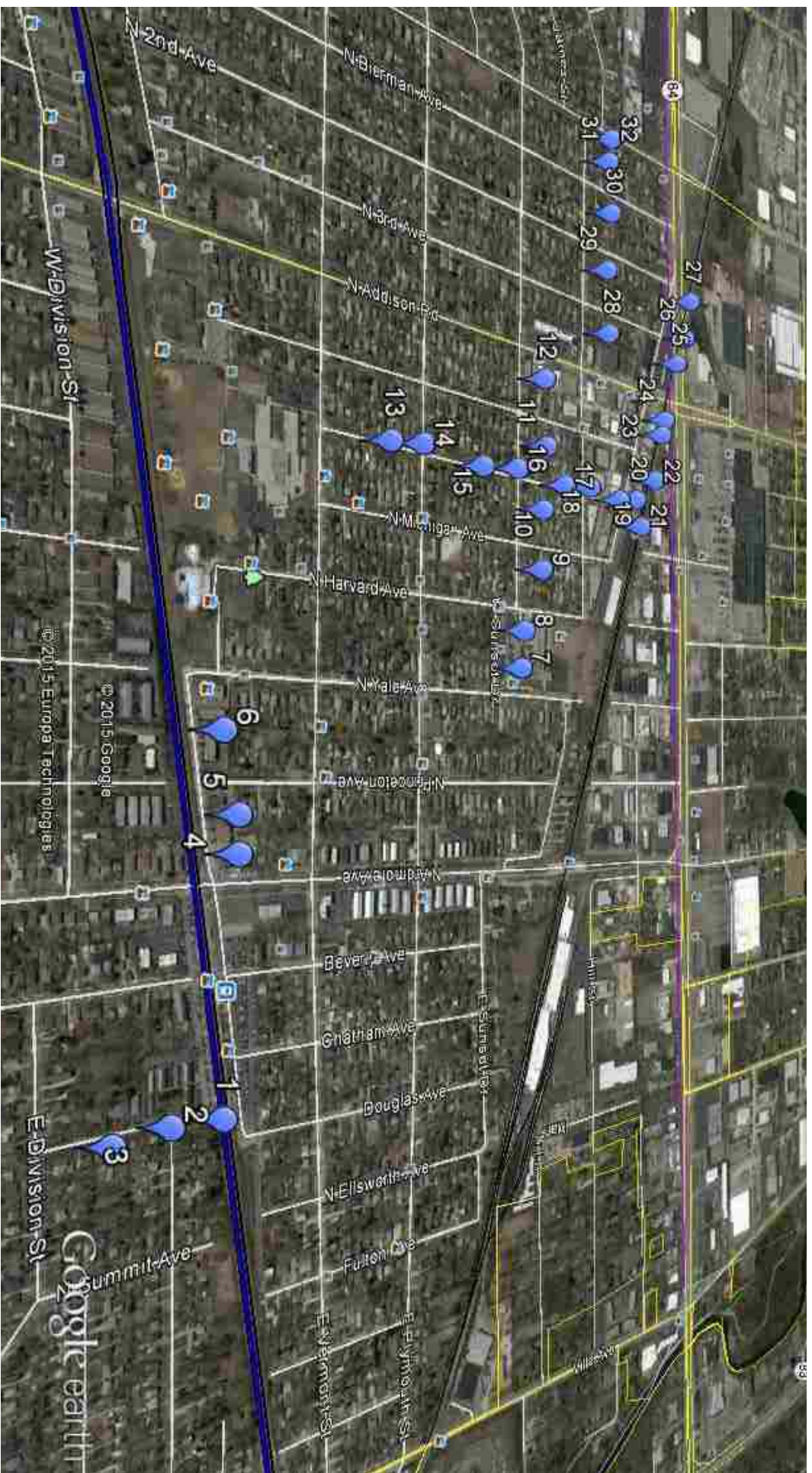

DIAGRAM IS FOR GENERAL LOCATION ONLY AND IS NOT INTENDED FOR CONSTRUCTION PURPOSES

P	MARK	P	N	MR156009
C	MARK	S	N.T.S.	
A	KCB	N	MR156009BLD	
	KCB		March 2015	

**Terracon**  
 Consulting Engineers & Scientists  
 555 Ambassador Drive Naperville, Illinois 60563  
 PH: 800.772.283 FAX: 800.572.848

BORING LOCATION DIAGRAM  
 PAVEMENT EVALUATION  
 MULTIPLE STREETS  
 VILLA PARK, ILLINOIS

Exhibit  
 A-2

# BORING LOG NO. 1

**PROJECT:** Pavement Rehabilitation -  
Village of Villa Park

**CLIENT:** Village of Villa Park IL  
Villa Park, Illinois

**SITE:** Multiple Streets  
Villa Park, Illinois

GRAPHIC LOG	LOCATION See Exhibit A-2	DEPTH (Ft.)	WATER LEVEL OBSERVATIONS	SAMPLE TYPE	RECOVERY (in.)	FIELD TEST RESULTS	HAND PENETROMETER, (psf)	SAMPLE NUMBER	WATER CONTENT (%)
	DEPTH								
	<b>ASPHALT</b> , Approximately 4.5"	0.4							
	<b>CRUSHED STONE AGGREGATE</b> , Approximately 8"	1.1							
	<b>LEAN TO FAT CLAY (CL/CH)</b> , trace sand and organics, dark brown, (possible buried topsoil)	3.0			14	18-19-11 N=30	1500	1	31
	<b>LEAN TO FAT CLAY (CL/CH)</b> , trace sand, brown and gray, stiff	5.5			15	6-4-4 N=8	3500	2	26
	<b>LEAN CLAY (CL)</b> , trace sand and gravel, brown, very stiff	7.5			15	6-7-8 N=15	1500	3	23
	<b>Boring Terminated at 7.5 Feet</b>								

Stratification lines are approximate. In-situ, the transition may be gradual.

Hammer Type: Automatic SPT Hammer

Advancement Method:  
Hollow Stem Auger

See Exhibit A-1 for description of field procedures

Notes:

Abandonment Method:  
Boring backfilled with soil cuttings upon completion.

See Appendix B for description of laboratory procedures and additional data (if any).

See Appendix C for explanation of symbols and abbreviations.

**WATER LEVEL OBSERVATIONS**

None, while drilling

None, after boring



Boring Started: 2/17/2015

Boring Completed: 2/17/2015

Drill Rig: GC

Driller: DS

Project No.: MR155009

Exhibit: A-3

THIS BORING LOG IS NOT VALID IF SEPARATED FROM ORIGINAL REPORT. GEO LOG-DEPTH TO BOTTOM OF PAGE MR155009.GPJ TERRACON2012.GDT 3/16/15



# BORING LOG NO. 3

**PROJECT:** Pavement Rehabilitation -  
Village of Villa Park

**CLIENT:** Village of Villa Park IL  
Villa Park, Illinois

**SITE:** Multiple Streets  
Villa Park, Illinois

GRAPHIC LOG	LOCATION See Exhibit A-2	DEPTH (Ft.)	WATER LEVEL OBSERVATIONS	SAMPLE TYPE	RECOVERY (In.)	FIELD TEST RESULTS	HAND PENETROMETER, (psf)	SAMPLE NUMBER	WATER CONTENT (%)
	DEPTH								
	<b>ASPHALT/CONCRETE</b> , Approximately 4"	0.4							
	<b>CRUSHED STONE AGGREGATE</b> , Approximately 5"	0.9							
	<b>FILL - LEAN CLAY</b> , trace sand and gravel, brown and gray, trace dark brown								
				X	16	7-8-5 N=13		1	23
				X	17	4-5-4 N=9		2	27
				X	10	7-6-5 N=11		3	27
	<b>Boring Terminated at 7.5 Feet</b>	7.5							

Stratification lines are approximate. In-situ, the transition may be gradual.

Hammer Type: Automatic SPT Hammer

Advancement Method:  
Hollow Stem Auger

See Exhibit A-1 for description of field procedures

Notes:

Abandonment Method:  
Boring backfilled with soil cuttings upon completion.

See Appendix B for description of laboratory procedures and additional data (if any).

See Appendix C for explanation of symbols and abbreviations.

**WATER LEVEL OBSERVATIONS**

*None, while drilling*

*None, after boring*



Boring Started: 2/17/2015

Boring Completed: 2/17/2015

Drill Rig: GC

Driller: DS

Project No.: MR155009

Exhibit: A-5

THIS BORING LOG IS NOT VALID IF SEPARATED FROM ORIGINAL REPORT. GEO LOG-DEPTH TO BOTTOM OF PAGE MR155009.GPJ TERRACON2012.GDT 3/16/15

# BORING LOG NO. 4

**PROJECT:** Pavement Rehabilitation -  
Village of Villa Park

**CLIENT:** Village of Villa Park IL  
Villa Park, Illinois

**SITE:** Multiple Streets  
Villa Park, Illinois

GRAPHIC LOG	LOCATION See Exhibit A-2	DEPTH (Ft.)	WATER LEVEL OBSERVATIONS	SAMPLE TYPE	RECOVERY (In.)	FIELD TEST RESULTS	HAND PENETROMETER, (psf)	SAMPLE NUMBER	WATER CONTENT (%)
	<b>CONCRETE</b> , Approximately 7"								
0.6									
	<b>CRUSHED STONE AGGREGATE</b> , Approximately 5"								
1.0									
	<b>SILTY CLAY (CL-ML)</b> , trace sand, brown and gray, soft to stiff			X	16	4-7-6 N=13	500	1	26
3.5									
	<b>LEAN CLAY (CL)</b> , trace sand and gravel, brown, stiff to very stiff			X	15	5-7-8 N=15	4000	2	22
5									
				X	16	8-9-10 N=19	5500	3	22
7.5									
	<b>Boring Terminated at 7.5 Feet</b>								
		10							

Stratification lines are approximate. In-situ, the transition may be gradual.

Hammer Type: Automatic SPT Hammer

Advancement Method:  
Hollow Stem Auger

See Exhibit A-1 for description of field procedures

Notes:

Abandonment Method:  
Boring backfilled with soil cuttings upon completion.

See Appendix B for description of laboratory procedures and additional data (if any).

See Appendix C for explanation of symbols and abbreviations.

**WATER LEVEL OBSERVATIONS**

None, while drilling

None, after boring



135 Ambassador Drive  
Naperville, Illinois

Boring Started: 2/17/2015

Boring Completed: 2/17/2015

Drill Rig: GC

Driller: DS

Project No.: MR155009

Exhibit: A-6

THIS BORING LOG IS NOT VALID IF SEPARATED FROM ORIGINAL REPORT. GEO LOG-DEPTH TO BOTTOM OF PAGE MR155009.GPJ TERRACON2012.GDT 3/16/15

# BORING LOG NO. 5

**PROJECT:** Pavement Rehabilitation -  
Village of Villa Park

**CLIENT:** Village of Villa Park IL  
Villa Park, Illinois

**SITE:** Multiple Streets  
Villa Park, Illinois

GRAPHIC LOG	LOCATION See Exhibit A-2	DEPTH (Ft.)	WATER LEVEL OBSERVATIONS	SAMPLE TYPE	RECOVERY (In.)	FIELD TEST RESULTS	HAND PENETROMETER, (psf)	SAMPLE NUMBER	WATER CONTENT (%)
	DEPTH								
0.4	<b>CONCRETE</b> , Approximately 9.5"								
3.5	<b>LEAN CLAY (CL)</b> , trace sand and gravel, brown, stiff				16	5-5-5 N=10	3000	1	24
5.5	<b>SILTY CLAY (CL-ML)</b> , trace sand, brown and gray, stiff	5			15	5-7-8 N=15	3500	2	18
7.5	<b>LEAN CLAY (CL)</b> , trace sand and gravel, brown, stiff to very stiff				16	4-5-6 N=11	6000	3	21
	<b>Boring Terminated at 7.5 Feet</b>	10							

Stratification lines are approximate. In-situ, the transition may be gradual.

Hammer Type: Automatic SPT Hammer

Advancement Method:  
Hollow Stem Auger

See Exhibit A-1 for description of field procedures

Notes:

Abandonment Method:  
Boring backfilled with soil cuttings upon completion.

See Appendix B for description of laboratory procedures and additional data (if any).

See Appendix C for explanation of symbols and abbreviations.

**WATER LEVEL OBSERVATIONS**

*None, while drilling*

*None, after boring*



Boring Started: 2/17/2015

Boring Completed: 2/17/2015

Drill Rig: GC

Driller: DS

Project No.: MR155009

Exhibit: A-7

THIS BORING LOG IS NOT VALID IF SEPARATED FROM ORIGINAL REPORT. GEO LOG-DEPTH TO BOTTOM OF PAGE MR155009.GPJ TERRACON2012.GDT 3/16/15

# BORING LOG NO. 6

**PROJECT:** Pavement Rehabilitation -  
Village of Villa Park

**CLIENT:** Village of Villa Park IL  
Villa Park, Illinois

**SITE:** Multiple Streets  
Villa Park, Illinois

GRAPHIC LOG	LOCATION See Exhibit A-2	DEPTH (Ft.)	WATER LEVEL OBSERVATIONS	SAMPLE TYPE	RECOVERY (In.)	FIELD TEST RESULTS	HAND PENETROMETER, (psf)	SAMPLE NUMBER	WATER CONTENT (%)
	DEPTH								
0.6	<b>CONCRETE</b> , Approximately 7.5"								
3.5	<b>FILL - LEAN CLAY, WITH SAND AND ORGANICS</b> , trace gravel, dark brown to black, (possible buried topsoil)			17		11-13-8 N=21		1	49
5.5	<b>LEAN TO FAT CLAY (CL/CH)</b> , trace sand, dark brown to brown, stiff	5		16		7-6-7 N=13	2500	2	30
7.5	<b>LEAN CLAY (CL)</b> , trace sand and gravel, brown, stiff to very stiff			17		6-6-7 N=13	4500	3	24
	<b>Boring Terminated at 7.5 Feet</b>	10							

Stratification lines are approximate. In-situ, the transition may be gradual.

Hammer Type: Automatic SPT Hammer

Advancement Method:  
Hollow Stem Auger

See Exhibit A-1 for description of field procedures

Notes:

Abandonment Method:  
Boring backfilled with soil cuttings upon completion.

See Appendix B for description of laboratory procedures and additional data (if any).

See Appendix C for explanation of symbols and abbreviations.

**WATER LEVEL OBSERVATIONS**

*None, while drilling*

*None, after boring*



135 Ambassador Drive  
Naperville, Illinois

Boring Started: 2/17/2015

Boring Completed: 2/17/2015

Drill Rig: GC

Driller: DS

Project No.: MR155009

Exhibit: A-8

THIS BORING LOG IS NOT VALID IF SEPARATED FROM ORIGINAL REPORT. GEO LOG-DEPTH TO BOTTOM OF PAGE MR155009.GPJ TERRACON2012.GDT 3/16/15

# BORING LOG NO. 7

**PROJECT:** Pavement Rehabilitation -  
Village of Villa Park

**CLIENT:** Village of Villa Park IL  
Villa Park, Illinois

**SITE:** Multiple Streets  
Villa Park, Illinois

GRAPHIC LOG	LOCATION See Exhibit A-2	DEPTH (Ft.)	WATER LEVEL OBSERVATIONS	SAMPLE TYPE	RECOVERY (In.)	FIELD TEST RESULTS	HAND PENETROMETER, (psf)	SAMPLE NUMBER	WATER CONTENT (%)
	DEPTH								
0.5	<b>CONCRETE</b> , Approximately 6.5"								
3.5	<b>LEAN TO FAT CLAY (CL/CH)</b> , trace sand, dark brown, brown and gray mottled, medium stiff to very stiff  Sample 1: frozen			16		14-11-10 N=21	1000	1	30
7.5	<b>LEAN CLAY (CL)</b> , trace sand and gravel, brown, trace gray, stiff to very stiff	5		17		6-6-5 N=11	4000	2	22
7.5	<b>Boring Terminated at 7.5 Feet</b>						7000	3	21

Stratification lines are approximate. In-situ, the transition may be gradual.

Hammer Type: Automatic SPT Hammer

Advancement Method:  
Hollow Stem Auger

See Exhibit A-1 for description of field procedures

Notes:

Abandonment Method:  
Boring backfilled with soil cuttings upon completion.

See Appendix B for description of laboratory procedures and additional data (if any).  
See Appendix C for explanation of symbols and abbreviations.

**WATER LEVEL OBSERVATIONS**

None, while drilling  
None, after boring



Boring Started: 2/17/2015

Boring Completed: 2/17/2015

Drill Rig: GC

Driller: DS

Project No.: MR155009

Exhibit: A-9

THIS BORING LOG IS NOT VALID IF SEPARATED FROM ORIGINAL REPORT. GEO LOG-DEPTH TO BOTTOM OF PAGE MR155009.GPJ TERRACON2012.GDT 3/16/15

# BORING LOG NO. 8

**PROJECT:** Pavement Rehabilitation -  
Village of Villa Park

**CLIENT:** Village of Villa Park IL  
Villa Park, Illinois

**SITE:** Multiple Streets  
Villa Park, Illinois

GRAPHIC LOG	LOCATION See Exhibit A-2	DEPTH (Ft.)	WATER LEVEL OBSERVATIONS	SAMPLE TYPE	RECOVERY (In.)	FIELD TEST RESULTS	HAND PENETROMETER, (psf)	SAMPLE NUMBER	WATER CONTENT (%)
	DEPTH								
0.4	<b>CONCRETE</b> , Approximately 5"								
0.8	<b>CRUSHED STONE AGGREGATE</b> , Approximately 5"								
1.5	<b>LEAN TO FAT CLAY</b> , trace gravel and organics, dark brown, (possible buried topsoil)								
3.5	<b>LEAN TO FAT CLAY (CL/CH)</b> , trace sand, gray, medium stiff				15	12-13-7 N=20	1000	1	33
5					16	5-7-8 N=15			
7.5	<b>LEAN CLAY (CL)</b> , trace sand and gravel, brown and gray, very stiff						8000	3	21
	<b>Boring Terminated at 7.5 Feet</b>								

Stratification lines are approximate. In-situ, the transition may be gradual.

Hammer Type: Automatic SPT Hammer

Advancement Method:  
Hollow Stem Auger

See Exhibit A-1 for description of field procedures

Notes:

Abandonment Method:  
Boring backfilled with soil cuttings upon completion.

See Appendix B for description of laboratory procedures and additional data (if any).

See Appendix C for explanation of symbols and abbreviations.

**WATER LEVEL OBSERVATIONS**

None, while drilling

None, after boring



Boring Started: 2/17/2015

Boring Completed: 2/17/2015

Drill Rig: GC

Driller: DS

Project No.: MR155009

Exhibit: A-10

THIS BORING LOG IS NOT VALID IF SEPARATED FROM ORIGINAL REPORT. GEO LOG-DEPTH TO BOTTOM OF PAGE MR155009.GPJ TERRACON2012.GDT 3/16/15

# BORING LOG NO. 9

**PROJECT:** Pavement Rehabilitation -  
Village of Villa Park

**CLIENT:** Village of Villa Park IL  
Villa Park, Illinois

**SITE:** Multiple Streets  
Villa Park, Illinois

GRAPHIC LOG	LOCATION See Exhibit A-2	DEPTH (Ft.)	WATER LEVEL OBSERVATIONS	SAMPLE TYPE	RECOVERY (In.)	FIELD TEST RESULTS	HAND PENETROMETER, (psf)	SAMPLE NUMBER	WATER CONTENT (%)
	<b>CONCRETE</b> , Approximately 6"	0.5							
	<b>CRUSHED STONE AGGREGATE</b> , Approximately 2"	0.7							
	<b>LEAN TO FAT CLAY (CL/CH)</b> , trace sand and organics, dark brown/dark gray, soft to very stiff  Sample 1: frozen	3.5		16		13-11-5 N=16	500	1	35
	<b>SILTY CLAY (CL-ML)</b> , trace sand and gravel, brown and gray, medium stiff to stiff	5.5		15		6-5-6 N=11	1500	2	17
	<b>LEAN CLAY (CL)</b> , trace sand and gravel, brown and gray, medium stiff	7.5		2000			2000	3	22
	<b>Boring Terminated at 7.5 Feet</b>								

Stratification lines are approximate. In-situ, the transition may be gradual.

Hammer Type: Automatic SPT Hammer

Advancement Method:  
Hollow Stem Auger

See Exhibit A-1 for description of field procedures

Notes:

Abandonment Method:  
Boring backfilled with soil cuttings upon completion.

See Appendix B for description of laboratory procedures and additional data (if any).  
See Appendix C for explanation of symbols and abbreviations.

**WATER LEVEL OBSERVATIONS**

None, while drilling  
None, after boring



Boring Started: 2/17/2015

Boring Completed: 2/17/2015

Drill Rig: GC

Driller: DS

Project No.: MR155009

Exhibit: A-11

THIS BORING LOG IS NOT VALID IF SEPARATED FROM ORIGINAL REPORT. GEO LOG-DEPTH TO BOTTOM OF PAGE MR155009.GPJ TERRACON2012.GDT 3/16/15

# BORING LOG NO. 10

**PROJECT:** Pavement Rehabilitation -  
Village of Villa Park

**CLIENT:** Village of Villa Park IL  
Villa Park, Illinois

**SITE:** Multiple Streets  
Villa Park, Illinois

GRAPHIC LOG	LOCATION See Exhibit A-2	DEPTH (Ft.)	WATER LEVEL OBSERVATIONS	SAMPLE TYPE	RECOVERY (In.)	FIELD TEST RESULTS	HAND PENETROMETER, (psf)	SAMPLE NUMBER	WATER CONTENT (%)
	DEPTH								
0.5	<b>CONCRETE</b> , Approximately 6.5"								
0.8	<b>AGGREGATE BASE COURSE</b> , Approximately 3"								
3.5	<b>LEAN TO FAT CLAY (CL/CH)</b> , trace sand and organics, dark brown, (possible buried topsoil)  Sample 1: frozen			15		18-12-7 N=19		1	28
5.0	<b>LEAN CLAY (CL)</b> , trace sand and gravel, gray, trace dark gray, medium stiff to stiff  brown	5		6		7-6-7 N=13	2000	2	28
7.5	<b>Boring Terminated at 7.5 Feet</b>						3000	3	22

Stratification lines are approximate. In-situ, the transition may be gradual.

Hammer Type: Automatic SPT Hammer

Advancement Method:  
Hollow Stem Auger

See Exhibit A-1 for description of field procedures

Notes:

Abandonment Method:  
Boring backfilled with soil cuttings upon completion.

See Appendix B for description of laboratory procedures and additional data (if any).

See Appendix C for explanation of symbols and abbreviations.

**WATER LEVEL OBSERVATIONS**

None, while drilling

None, after boring



Boring Started: 2/17/2015

Boring Completed: 2/17/2015

Drill Rig: GC

Driller: DS

Project No.: MR155009

Exhibit: A-12

THIS BORING LOG IS NOT VALID IF SEPARATED FROM ORIGINAL REPORT. GEO LOG-DEPTH TO BOTTOM OF PAGE MR155009.GPJ TERRACON2012.GDT 3/16/15

# BORING LOG NO. 11

**PROJECT:** Pavement Rehabilitation -  
Village of Villa Park

**CLIENT:** Village of Villa Park IL  
Villa Park, Illinois

**SITE:** Multiple Streets  
Villa Park, Illinois

GRAPHIC LOG	LOCATION See Exhibit A-2	DEPTH (Ft.)	WATER LEVEL OBSERVATIONS	SAMPLE TYPE	RECOVERY (In.)	FIELD TEST RESULTS	HAND PENETROMETER, (psf)	SAMPLE NUMBER	WATER CONTENT (%)
DEPTH									
0.5	<b>CONCRETE</b> , Approximately 6"								
0.8	<b>CRUSHED STONE AGGREGATE</b> , Approximately 3"								
3.5	<b>LEAN TO FAT CLAY (CL/CH)</b> , trace sand, gray/dark gray, medium stiff to stiff  Sample 1: frozen			12		9-9-4 N=13	1500	1	28
5	<b>LEAN CLAY (CL)</b> , trace sand and gravel, brown and gray, medium stiff to stiff			14		5-5-5 N=10	1500	2	21
7.5	<b>LEAN CLAY (CL)</b> , trace sand and gravel, brown and gray, medium stiff to stiff						4000	3	25
	<b>Boring Terminated at 7.5 Feet</b>								

Stratification lines are approximate. In-situ, the transition may be gradual.

Hammer Type: Automatic SPT Hammer

Advancement Method:  
Hollow Stem Auger

See Exhibit A-1 for description of field procedures

Notes:

Abandonment Method:  
Boring backfilled with soil cuttings upon completion.

See Appendix B for description of laboratory procedures and additional data (if any).

See Appendix C for explanation of symbols and abbreviations.

**WATER LEVEL OBSERVATIONS**

*None, while drilling*

*None, after boring*



135 Ambassador Drive  
Naperville, Illinois

Boring Started: 2/17/2015

Boring Completed: 2/17/2015

Drill Rig: GC

Driller: DS

Project No.: MR155009

Exhibit: A-13

THIS BORING LOG IS NOT VALID IF SEPARATED FROM ORIGINAL REPORT. GEO LOG-DEPTH TO BOTTOM OF PAGE MR155009.GPJ TERRACON2012.GDT 3/16/15

# BORING LOG NO. 12

**PROJECT:** Pavement Rehabilitation -  
Village of Villa Park

**CLIENT:** Village of Villa Park IL  
Villa Park, Illinois

**SITE:** Multiple Streets  
Villa Park, Illinois

GRAPHIC LOG	LOCATION See Exhibit A-2	DEPTH (Ft.)	WATER LEVEL OBSERVATIONS	SAMPLE TYPE	RECOVERY (In.)	FIELD TEST RESULTS	HAND PENETROMETER, (psf)	SAMPLE NUMBER	WATER CONTENT (%)
	DEPTH								
	<b>ASPHALT</b> , Approximately 6"								
	0.5								
	<b>CRUSHED STONE AGGREGATE</b> , Approximately 3"								
	0.8								
	<b>LEAN TO FAT CLAY (CL/CH)</b> , trace sand, brown, dark brown and gray, medium stiff to stiff								
				16		6-5-3 N=8	2000	1	33
	3.0								
	<b>LEAN CLAY (CL)</b> , trace sand and gravel, brown/reddish brown and gray, medium stiff to stiff								
				15		5-5-5 N=10	1500	2	17
							3000	3	13
	7.5								
	<b>Boring Terminated at 7.5 Feet</b>								

Stratification lines are approximate. In-situ, the transition may be gradual.

Hammer Type: Automatic SPT Hammer

Advancement Method:  
Hollow Stem Auger

See Exhibit A-1 for description of field procedures

Notes:

Abandonment Method:  
Boring backfilled with soil cuttings upon completion.

See Appendix B for description of laboratory procedures and additional data (if any).

See Appendix C for explanation of symbols and abbreviations.

**WATER LEVEL OBSERVATIONS**

None, while drilling

None, after boring



135 Ambassador Drive  
Naperville, Illinois

Boring Started: 2/17/2015

Boring Completed: 2/17/2015

Drill Rig: GC

Driller: DS

Project No.: MR155009

Exhibit: A-14

THIS BORING LOG IS NOT VALID IF SEPARATED FROM ORIGINAL REPORT. GEO LOG-DEPTH TO BOTTOM OF PAGE MR155009.GPJ TERRACON2012.GDT 3/16/15

# BORING LOG NO. 13

**PROJECT:** Pavement Rehabilitation -  
Village of Villa Park

**CLIENT:** Village of Villa Park IL  
Villa Park, Illinois

**SITE:** Multiple Streets  
Villa Park, Illinois

GRAPHIC LOG	LOCATION See Exhibit A-2	DEPTH (Ft.)	WATER LEVEL OBSERVATIONS	SAMPLE TYPE	RECOVERY (In.)	FIELD TEST RESULTS	HAND PENETROMETER, (psf)	SAMPLE NUMBER	WATER CONTENT (%)
	DEPTH								
	<b>ASPHALT</b> , Approximately 3.5"	0.4							
	<b>CRUSHED STONE AGGREGATE</b> , Approximately 6"	0.8							
	<b>FILL - LEAN TO FAT CLAY</b> , with organics, trace sand, dark brown to black								
	dark brown/dark gray, (possible buried topsoil)			15		21-23-9 N=32		1	30
				16		5-8-9 N=17		2	30
		5							
	<b>LEAN CLAY (CL)</b> , trace sand and gravel, brown and gray, stiff	5.5					3000	3	21
	<b>Boring Terminated at 7.5 Feet</b>	7.5							
		10							

Stratification lines are approximate. In-situ, the transition may be gradual.

Hammer Type: Automatic SPT Hammer

Advancement Method:  
Hollow Stem Auger

See Exhibit A-1 for description of field procedures

Notes:

Abandonment Method:  
Boring backfilled with soil cuttings upon completion.

See Appendix B for description of laboratory procedures and additional data (if any).

See Appendix C for explanation of symbols and abbreviations.

**WATER LEVEL OBSERVATIONS**

*None, while drilling*

*None, after boring*



135 Ambassador Drive  
Naperville, Illinois

Boring Started: 2/18/2015

Boring Completed: 2/18/2015

Drill Rig: GC

Driller: DS

Project No.: MR155009

Exhibit: A-15

THIS BORING LOG IS NOT VALID IF SEPARATED FROM ORIGINAL REPORT. GEO LOG-DEPTH TO BOTTOM OF PAGE MR155009.GPJ TERRACON2012.GDT 3/16/15

# BORING LOG NO. 14

**PROJECT:** Pavement Rehabilitation -  
Village of Villa Park

**CLIENT:** Village of Villa Park IL  
Villa Park, Illinois

**SITE:** Multiple Streets  
Villa Park, Illinois

GRAPHIC LOG	LOCATION See Exhibit A-2	DEPTH (Ft.)	WATER LEVEL OBSERVATIONS	SAMPLE TYPE	RECOVERY (In.)	FIELD TEST RESULTS	HAND PENETROMETER, (psf)	SAMPLE NUMBER	WATER CONTENT (%)
	<b>ASPHALT</b> , Approximately 6"	0.6							
	<b>CRUSHED STONE AGGREGATE</b> , Approximately 6"	1.1							
	<b>FILL - SANDY GRAVEL (CRUSHED LIMESTONE)</b> , trace silt, brown, wet	3.0				18-21-16 N=37		1	7
	<b>FILL - LEAN CLAY</b> , trace sand, gravel and organics, dark brown	5.0			6	6-7-7 N=14		2	25
	<b>LEAN CLAY (CL)</b> , trace sand and gravel, brown/gray, medium stiff	6.5			8	4-4-3 N=7	1000	3	32
	<b>Boring Terminated at 7.5 Feet</b>								

Stratification lines are approximate. In-situ, the transition may be gradual.

Hammer Type: Automatic SPT Hammer

Advancement Method:  
Hollow Stem Auger

See Exhibit A-1 for description of field procedures

Notes:

Abandonment Method:  
Boring backfilled with soil cuttings upon completion.

See Appendix B for description of laboratory procedures and additional data (if any).

See Appendix C for explanation of symbols and abbreviations.

**WATER LEVEL OBSERVATIONS**

*None, while drilling*

*None, after boring*



135 Ambassador Drive  
Naperville, Illinois

Boring Started: 2/18/2015

Boring Completed: 2/18/2015

Drill Rig: GC

Driller: DS

Project No.: MR155009

Exhibit: A-16

THIS BORING LOG IS NOT VALID IF SEPARATED FROM ORIGINAL REPORT. GEO LOG-DEPTH TO BOTTOM OF PAGE MR155009.GPJ TERRACON2012.GDT 3/16/15

# BORING LOG NO. 15

**PROJECT:** Pavement Rehabilitation -  
Village of Villa Park

**CLIENT:** Village of Villa Park IL  
Villa Park, Illinois

**SITE:** Multiple Streets  
Villa Park, Illinois

GRAPHIC LOG	LOCATION See Exhibit A-2	DEPTH (Ft.)	WATER LEVEL OBSERVATIONS	SAMPLE TYPE	RECOVERY (In.)	FIELD TEST RESULTS	HAND PENETROMETER, (psf)	SAMPLE NUMBER	WATER CONTENT (%)
	<b>ASPHALT</b> , Approximately 5"	0.4							
	<b>CRUSHED STONE AGGREGATE</b> , Approximately 8"	1.1							
	<b>FILL - LEAN CLAY</b> , trace sand and gravel, brown, gray, trace dark brown, soft				15	17-14-7 N=21		1	25
	<b>LEAN CLAY (CL)</b> , trace sand and gravel, brown and gray, stiff to medium stiff	3.5			14	7-5-4 N=9	4000	2	22
		5							
					6	3-4-4 N=8	1500	3	28
	<b>Boring Terminated at 7.5 Feet</b>	7.5							
		10							

Stratification lines are approximate. In-situ, the transition may be gradual.

Hammer Type: Automatic SPT Hammer

Advancement Method:  
Hollow Stem Auger

See Exhibit A-1 for description of field procedures

Notes:

Abandonment Method:  
Boring backfilled with soil cuttings upon completion.

See Appendix B for description of laboratory procedures and additional data (if any).

See Appendix C for explanation of symbols and abbreviations.

**WATER LEVEL OBSERVATIONS**

*None, while drilling*

*None, after boring*



Boring Started: 2/18/2015

Boring Completed: 2/18/2015

Drill Rig: GC

Driller: DS

Project No.: MR155009

Exhibit: A-17

THIS BORING LOG IS NOT VALID IF SEPARATED FROM ORIGINAL REPORT. GEO LOG-DEPTH TO BOTTOM OF PAGE MR155009.GPJ TERRACON2012.GDT 3/16/15

# BORING LOG NO. 16

**PROJECT:** Pavement Rehabilitation -  
Village of Villa Park

**CLIENT:** Village of Villa Park IL  
Villa Park, Illinois

**SITE:** Multiple Streets  
Villa Park, Illinois

GRAPHIC LOG	LOCATION See Exhibit A-2	DEPTH (Ft.)	WATER LEVEL OBSERVATIONS	SAMPLE TYPE	RECOVERY (In.)	FIELD TEST RESULTS	HAND PENETROMETER, (psf)	SAMPLE NUMBER	WATER CONTENT (%)
	DEPTH								
	0.3 <b>ASPHALT</b> , Approximately 4"								
	0.8 <b>CRUSHED STONE AGGREGATE</b> , Approximately 6"								
	7.5 <b>LEAN CLAY (CL)</b> , trace sand and gravel, brown and gray, stiff to hard								
	Sample 1: frozen			16		15-15-10 N=25	2500	1	23
		5		15		7-8-9 N=17	9000+	2	19
							7000	3	20
	7.5 <b>Boring Terminated at 7.5 Feet</b>								

Stratification lines are approximate. In-situ, the transition may be gradual.

Hammer Type: Automatic SPT Hammer

Advancement Method:  
Hollow Stem Auger

See Exhibit A-1 for description of field procedures

Notes:

Abandonment Method:  
Boring backfilled with soil cuttings upon completion.

See Appendix B for description of laboratory procedures and additional data (if any).

See Appendix C for explanation of symbols and abbreviations.

**WATER LEVEL OBSERVATIONS**

*None, while drilling*

*None, after boring*



Boring Started: 2/18/2015

Boring Completed: 2/18/2015

Drill Rig: GC

Driller: DS

Project No.: MR155009

Exhibit: A-18

THIS BORING LOG IS NOT VALID IF SEPARATED FROM ORIGINAL REPORT. GEO LOG-DEPTH TO BOTTOM OF PAGE MR155009.GPJ TERRACON2012.GDT 3/16/15



# BORING LOG NO. 18

**PROJECT:** Pavement Rehabilitation -  
Village of Villa Park

**CLIENT:** Village of Villa Park IL  
Villa Park, Illinois

**SITE:** Multiple Streets  
Villa Park, Illinois

GRAPHIC LOG	LOCATION See Exhibit A-2	DEPTH (Ft.)	WATER LEVEL OBSERVATIONS	SAMPLE TYPE	RECOVERY (In.)	FIELD TEST RESULTS	HAND PENETROMETER, (psf)	SAMPLE NUMBER	WATER CONTENT (%)
	<b>ASPHALT</b> , Approximately 4.5"	0.4							
	<b>CRUSHED STONE AGGREGATE</b> , Approximately 6"	0.9							
	<b>FILL - LEAN TO FAT CLAY</b> , with organics, trace sand, dark brown to black, (possible buried topsoil)	3.0			15	14-7-5 N=12		1	46
	<b>LEAN CLAY (CL)</b> , trace sand and gravel, brown and gray, stiff to very stiff	7.5			16	6-7-7 N=14	6000	2	22
	<b>Boring Terminated at 7.5 Feet</b>						3500	3	25

Stratification lines are approximate. In-situ, the transition may be gradual.

Hammer Type: Automatic SPT Hammer

Advancement Method:  
Hollow Stem Auger

See Exhibit A-1 for description of field procedures

Notes:

Abandonment Method:  
Boring backfilled with soil cuttings upon completion.

See Appendix B for description of laboratory procedures and additional data (if any).

See Appendix C for explanation of symbols and abbreviations.

**WATER LEVEL OBSERVATIONS**

*None, while drilling*

*None, after boring*



Boring Started: 2/18/2015

Boring Completed: 2/18/2015

Drill Rig: GC

Driller: DS

Project No.: MR155009

Exhibit: A-20

THIS BORING LOG IS NOT VALID IF SEPARATED FROM ORIGINAL REPORT. GEO LOG-DEPTH TO BOTTOM OF PAGE MR155009.GPJ TERRACON2012.GDT 3/16/15

# BORING LOG NO. 19

**PROJECT:** Pavement Rehabilitation -  
Village of Villa Park

**CLIENT:** Village of Villa Park IL  
Villa Park, Illinois

**SITE:** Multiple Streets  
Villa Park, Illinois

GRAPHIC LOG	LOCATION See Exhibit A-2	DEPTH (Ft.)	WATER LEVEL OBSERVATIONS	SAMPLE TYPE	RECOVERY (In.)	FIELD TEST RESULTS	HAND PENETROMETER, (psf)	SAMPLE NUMBER	WATER CONTENT (%)
	DEPTH								
0.7	<b>CONCRETE</b> , Approximately 8.5"								
1.4	<b>CRUSHED STONE AGGREGATE</b> , Approximately 9"								
3.0	<b>LEAN TO FAT CLAY (CL/CH)</b> , trace sand, gray, soft  Sample 1: frozen			16		23-24-15 N=39	3000	1	27
5.0	<b>LEAN CLAY (CL)</b> , trace sand and gravel, brown and gray, stiff to very stiff  Sample 2: occasional light gray sand/gravel pockets	5		15		8-9-9 N=18	3000	2	26
7.5	<b>Boring Terminated at 7.5 Feet</b>						4500	3	22

Stratification lines are approximate. In-situ, the transition may be gradual.

Hammer Type: Automatic SPT Hammer

Advancement Method:  
Hollow Stem Auger

See Exhibit A-1 for description of field procedures

Notes:

Abandonment Method:  
Boring backfilled with soil cuttings upon completion.

See Appendix B for description of laboratory procedures and additional data (if any).

See Appendix C for explanation of symbols and abbreviations.

**WATER LEVEL OBSERVATIONS**

*None, while drilling*

*None, after boring*



Boring Started: 2/18/2015

Boring Completed: 2/18/2015

Drill Rig: GC

Driller: DS

Project No.: MR155009

Exhibit: A-21

THIS BORING LOG IS NOT VALID IF SEPARATED FROM ORIGINAL REPORT. GEO LOG-DEPTH TO BOTTOM OF PAGE MR155009.GPJ TERRACON2012.GDT 3/16/15



# BORING LOG NO. 21

**PROJECT:** Pavement Rehabilitation -  
Village of Villa Park

**CLIENT:** Village of Villa Park IL  
Villa Park, Illinois

**SITE:** Multiple Streets  
Villa Park, Illinois

GRAPHIC LOG	LOCATION See Exhibit A-2	DEPTH (Ft.)	WATER LEVEL OBSERVATIONS	SAMPLE TYPE	RECOVERY (In.)	FIELD TEST RESULTS	HAND PENETROMETER, (psf)	SAMPLE NUMBER	WATER CONTENT (%)
	DEPTH								
	0.3 <b>ASPHALT</b> , Approximately 3"								
	0.8 <b>CRUSHED STONE AGGREGATE</b> , Approximately 8"								
	7.5 <b>LEAN CLAY (CL)</b> , trace sand and gravel, brown and gray, stiff to very stiff								
				13		13-7-5 N=12	2500	1	29
		5		14		4-4-4 N=8	4000	2	23
				15		4-5-6 N=11	5000	3	22
		10							
	<b>Boring Terminated at 7.5 Feet</b>								

Stratification lines are approximate. In-situ, the transition may be gradual.

Hammer Type: Automatic SPT Hammer

Advancement Method:  
Hollow Stem Auger

See Exhibit A-1 for description of field procedures

Notes:

Abandonment Method:  
Boring backfilled with soil cuttings upon completion.

See Appendix B for description of laboratory procedures and additional data (if any).

See Appendix C for explanation of symbols and abbreviations.

**WATER LEVEL OBSERVATIONS**

*None, while drilling*

*None, after boring*



Boring Started: 2/20/2015

Boring Completed: 2/20/2015

Drill Rig: GC

Driller: DS

Project No.: MR155009

Exhibit: A-23

THIS BORING LOG IS NOT VALID IF SEPARATED FROM ORIGINAL REPORT. GEO LOG-DEPTH TO BOTTOM OF PAGE MR155009.GPJ TERRACON2012.GDT 3/16/15

# BORING LOG NO. 22

**PROJECT:** Pavement Rehabilitation -  
Village of Villa Park

**CLIENT:** Village of Villa Park IL  
Villa Park, Illinois

**SITE:** Multiple Streets  
Villa Park, Illinois

GRAPHIC LOG	LOCATION See Exhibit A-2	DEPTH (Ft.)	WATER LEVEL OBSERVATIONS	SAMPLE TYPE	RECOVERY (In.)	FIELD TEST RESULTS	HAND PENETROMETER, (psf)	SAMPLE NUMBER	WATER CONTENT (%)
	DEPTH								
0.7	<b>CONCRETE</b> , Approximately 8.5"								
1.0	<b>CRUSHED STONE AGGREGATE</b> , Approximately 3"								
7.5	<b>LEAN CLAY (CL)</b> , trace sand and gravel, brown and gray, medium stiff to very stiff			X	15	22-17-7 N=24	2000	1	23
		5		X	14	7-8-9 N=17	4000	2	22
				X	16	5-9-10 N=19	8000	3	21
	<b>Boring Terminated at 7.5 Feet</b>	10							

Stratification lines are approximate. In-situ, the transition may be gradual.

Hammer Type: Automatic SPT Hammer

Advancement Method:  
Hollow Stem Auger

See Exhibit A-1 for description of field procedures

Notes:

Abandonment Method:  
Boring backfilled with soil cuttings upon completion.

See Appendix B for description of laboratory procedures and additional data (if any).

See Appendix C for explanation of symbols and abbreviations.

**WATER LEVEL OBSERVATIONS**

None, while drilling

None, after boring



135 Ambassador Drive  
Naperville, Illinois

Boring Started: 2/20/2015

Boring Completed: 2/20/2015

Drill Rig: GC

Driller: DS

Project No.: MR155009

Exhibit: A-24

THIS BORING LOG IS NOT VALID IF SEPARATED FROM ORIGINAL REPORT. GEO LOG-DEPTH TO BOTTOM OF PAGE MR155009.GPJ TERRACON2012.GDT 3/16/15

# BORING LOG NO. 23

**PROJECT:** Pavement Rehabilitation -  
Village of Villa Park

**CLIENT:** Village of Villa Park IL  
Villa Park, Illinois

**SITE:** Multiple Streets  
Villa Park, Illinois

GRAPHIC LOG	LOCATION See Exhibit A-2	DEPTH (Ft.)	WATER LEVEL OBSERVATIONS	SAMPLE TYPE	RECOVERY (In.)	FIELD TEST RESULTS	HAND PENETROMETER, (psf)	SAMPLE NUMBER	WATER CONTENT (%)
	DEPTH								
0.6	<b>CONCRETE</b> , Approximately 7.5"								
0.9	<b>CRUSHED STONE AGGREGATE</b> , Approximately 3"								
1.5	<b>LEAN CLAY (CL)</b> , trace sand and gravel, gray, trace brown, stiff to very stiff								
3.0	Sample 1: occasional silt pockets			15		15-11-5 N=16	3000	1	23
4.5	to brown and gray			16		7-8-9 N=17	6500	2	21
6.0		5							
7.5							5000	3	17
	<b>Boring Terminated at 7.5 Feet</b>								

Stratification lines are approximate. In-situ, the transition may be gradual.

Hammer Type: Automatic SPT Hammer

Advancement Method:  
Hollow Stem Auger

See Exhibit A-1 for description of field procedures

Notes:

Abandonment Method:  
Boring backfilled with soil cuttings upon completion.

See Appendix B for description of laboratory procedures and additional data (if any).

See Appendix C for explanation of symbols and abbreviations.

**WATER LEVEL OBSERVATIONS**

None, while drilling

None, after boring



Boring Started: 2/20/2015

Boring Completed: 2/20/2015

Drill Rig: GC

Driller: DS

Project No.: MR155009

Exhibit: A-25

THIS BORING LOG IS NOT VALID IF SEPARATED FROM ORIGINAL REPORT. GEO LOG-DEPTH TO BOTTOM OF PAGE MR155009.GPJ TERRACON2012.GDT 3/16/15

# BORING LOG NO. 24

**PROJECT:** Pavement Rehabilitation -  
Village of Villa Park

**CLIENT:** Village of Villa Park IL  
Villa Park, Illinois

**SITE:** Multiple Streets  
Villa Park, Illinois

GRAPHIC LOG	LOCATION See Exhibit A-2	DEPTH (Ft.)	WATER LEVEL OBSERVATIONS	SAMPLE TYPE	RECOVERY (In.)	FIELD TEST RESULTS	HAND PENETROMETER, (psf)	SAMPLE NUMBER	WATER CONTENT (%)
DEPTH									
0.8	<b>CONCRETE</b> , Approximately 9"								
1.2	<b>CRUSHED STONE AGGREGATE</b> , Approximately 5"								
3.5	<b>FILL - SANDY GRAVEL WITH SILT</b> , light gray, (crushed limestone)			15		27-29-11 N=40		1	6
7.5	<b>LEAN TO FAT CLAY (CL/CH)</b> , trace sand, brown and gray mottled, stiff to very stiff	5		11		7-8-9 N=17	3500	2	25
7.5	<b>Boring Terminated at 7.5 Feet</b>						3000	3	28

Stratification lines are approximate. In-situ, the transition may be gradual.

Hammer Type: Automatic SPT Hammer

Advancement Method:  
Hollow Stem Auger

See Exhibit A-1 for description of field procedures

Notes:

Abandonment Method:  
Boring backfilled with soil cuttings upon completion.

See Appendix B for description of laboratory procedures and additional data (if any).

See Appendix C for explanation of symbols and abbreviations.

**WATER LEVEL OBSERVATIONS**

*None, while drilling*

*None, after boring*



Boring Started: 2/20/2015

Boring Completed: 2/20/2015

Drill Rig: GC

Driller: DS

Project No.: MR155009

Exhibit: A-26

THIS BORING LOG IS NOT VALID IF SEPARATED FROM ORIGINAL REPORT. GEO LOG-DEPTH TO BOTTOM OF PAGE MR155009.GPJ TERRACON2012.GDT 3/16/15

# BORING LOG NO. 25

**PROJECT:** Pavement Rehabilitation -  
Village of Villa Park

**CLIENT:** Village of Villa Park IL  
Villa Park, Illinois

**SITE:** Multiple Streets  
Villa Park, Illinois

GRAPHIC LOG	LOCATION See Exhibit A-2	DEPTH (Ft.)	WATER LEVEL OBSERVATIONS	SAMPLE TYPE	RECOVERY (In.)	FIELD TEST RESULTS	HAND PENETROMETER, (psf)	SAMPLE NUMBER	WATER CONTENT (%)
	<b>CONCRETE</b> , Approximately 8"	0.7							
	<b>CRUSHED STONE AGGREGATE</b> , Approximately 4"	1.0							
	<b>FILL - LEAN CLAY WITH SAND</b> , trace gravel and organics, dark gray								
	Sample 1: frozen				16	31-27-11 N=38		1	9
	<b>LEAN CLAY (CL)</b> , trace sand, brown and gray mottled, stiff to very stiff								
	Sample 2: occasional sand seams				15	8-8-8 N=16	3000	2	20
							4000	3	22
	<b>Boring Terminated at 7.5 Feet</b>	7.5							

Stratification lines are approximate. In-situ, the transition may be gradual.

Hammer Type: Automatic SPT Hammer

Advancement Method:  
Hollow Stem Auger

See Exhibit A-1 for description of field procedures

Notes:

Abandonment Method:  
Boring backfilled with soil cuttings upon completion.

See Appendix B for description of laboratory procedures and additional data (if any).

See Appendix C for explanation of symbols and abbreviations.

**WATER LEVEL OBSERVATIONS**

*None, while drilling*

*None, after boring*



Boring Started: 2/20/2015

Boring Completed: 2/20/2015

Drill Rig: GC

Driller: DS

Project No.: MR155009

Exhibit: A-27

THIS BORING LOG IS NOT VALID IF SEPARATED FROM ORIGINAL REPORT. GEO LOG-DEPTH TO BOTTOM OF PAGE MR155009.GPJ TERRACON2012.GDT 3/16/15

# BORING LOG NO. 26

**PROJECT:** Pavement Rehabilitation -  
Village of Villa Park

**CLIENT:** Village of Villa Park IL  
Villa Park, Illinois

**SITE:** Multiple Streets  
Villa Park, Illinois

GRAPHIC LOG	LOCATION See Exhibit A-2	DEPTH (Ft.)	WATER LEVEL OBSERVATIONS	SAMPLE TYPE	RECOVERY (In.)	FIELD TEST RESULTS	HAND PENETROMETER, (psf)	SAMPLE NUMBER	WATER CONTENT (%)
	<b>CONCRETE</b> , Approximately 8"	0.7							
	<b>CRUSHED STONE AGGREGATE</b> , Approximately 6"	1.2							
	<b>LEAN TO FAT CLAY</b> , trace sand, brown/dark brown, stiff  Sample 1: frozen	3.0			16	23-16-8 N=24	2500	1	27
	<b>LEAN CLAY (CL)</b> , trace sand, brown and gray mottled, stiff	5.0			15	6-7-7 N=14	3500	2	17
		7.5			9	7-5-6 N=11	3500	3	14
	<b>Boring Terminated at 7.5 Feet</b>								

Stratification lines are approximate. In-situ, the transition may be gradual.

Hammer Type: Automatic SPT Hammer

Advancement Method:  
Hollow Stem Auger

See Exhibit A-1 for description of field procedures

Notes:

Abandonment Method:  
Boring backfilled with soil cuttings upon completion.

See Appendix B for description of laboratory procedures and additional data (if any).

See Appendix C for explanation of symbols and abbreviations.

**WATER LEVEL OBSERVATIONS**

*None, while drilling*

*None, after boring*



135 Ambassador Drive  
Naperville, Illinois

Boring Started: 2/20/2015

Boring Completed: 2/20/2015

Drill Rig: GC

Driller: DS

Project No.: MR155009

Exhibit: A-28

THIS BORING LOG IS NOT VALID IF SEPARATED FROM ORIGINAL REPORT. GEO LOG-DEPTH TO BOTTOM OF PAGE MR155009.GPJ TERRACON2012.GDT 3/16/15

# BORING LOG NO. 27

**PROJECT:** Pavement Rehabilitation -  
Village of Villa Park

**CLIENT:** Village of Villa Park IL  
Villa Park, Illinois

**SITE:** Multiple Streets  
Villa Park, Illinois

GRAPHIC LOG	LOCATION See Exhibit A-2	DEPTH (Ft.)	WATER LEVEL OBSERVATIONS	SAMPLE TYPE	RECOVERY (In.)	FIELD TEST RESULTS	HAND PENETROMETER, (psf)	SAMPLE NUMBER	WATER CONTENT (%)
	<b>CONCRETE</b> , Approximately 8"	0.7							
	<b>CRUSHED STONE AGGREGATE</b> , Approximately 6"	1.2							
	<b>FILL - SANDY GRAVEL</b> , trace sand, light gray, (crushed limestone)				14	31-29-18 N=47		1	11
	<b>LEAN TO FAT CLAY (CL/CH)</b> , trace sand, brown and gray mottled, stiff	3.5			15	4-5-7 N=12	3000	2	26
	<b>LEAN CLAY (CL)</b> , trace sand, brown/gray, stiff	5.5			8	7-5-4 N=9	4000	3	23
	<b>Boring Terminated at 7.5 Feet</b>	7.5							
		10							

Stratification lines are approximate. In-situ, the transition may be gradual.

Hammer Type: Automatic SPT Hammer

Advancement Method:  
Hollow Stem Auger

See Exhibit A-1 for description of field procedures

Notes:

Abandonment Method:  
Boring backfilled with soil cuttings upon completion.

See Appendix B for description of laboratory procedures and additional data (if any).

See Appendix C for explanation of symbols and abbreviations.

**WATER LEVEL OBSERVATIONS**

*None, while drilling*

*None, after boring*



135 Ambassador Drive  
Naperville, Illinois

Boring Started: 2/20/2015

Boring Completed: 2/20/2015

Drill Rig: GC

Driller: DS

Project No.: MR155009

Exhibit: A-29

THIS BORING LOG IS NOT VALID IF SEPARATED FROM ORIGINAL REPORT. GEO LOG-DEPTH TO BOTTOM OF PAGE MR155009.GPJ TERRACON2012.GDT 3/16/15

# BORING LOG NO. 28

**PROJECT:** Pavement Rehabilitation -  
Village of Villa Park

**CLIENT:** Village of Villa Park IL  
Villa Park, Illinois

**SITE:** Multiple Streets  
Villa Park, Illinois

GRAPHIC LOG	LOCATION See Exhibit A-2	DEPTH (Ft.)	WATER LEVEL OBSERVATIONS	SAMPLE TYPE	RECOVERY (In.)	FIELD TEST RESULTS	HAND PENETROMETER, (psf)	SAMPLE NUMBER	WATER CONTENT (%)
	DEPTH								
0.5	<b>CONCRETE</b> , Approximately 6.5"								
0.9	<b>CRUSHED STONE AGGREGATE</b> , Approximately 5"								
3.5	<b>LEAN CLAY (CL)</b> , trace sand, brown/dark brown, medium stiff  Sample 1: frozen			X	15	17-22-11 N=33	1000	1	35
5.0		5		X	14	5-7-8 N=15	4500	2	19
7.5	<b>LEAN CLAY (CL)</b> , trace sand and gravel, brown and gray mottled, medium stiff to very stiff			X	10	7-7-7 N=14	2000	3	20
	<b>Boring Terminated at 7.5 Feet</b>	10							

Stratification lines are approximate. In-situ, the transition may be gradual.

Hammer Type: Automatic SPT Hammer

Advancement Method:  
Hollow Stem Auger

See Exhibit A-1 for description of field procedures

Notes:

Abandonment Method:  
Boring backfilled with soil cuttings upon completion.

See Appendix B for description of laboratory procedures and additional data (if any).

See Appendix C for explanation of symbols and abbreviations.

**WATER LEVEL OBSERVATIONS**

*None, while drilling*

*None, after boring*



135 Ambassador Drive  
Naperville, Illinois

Boring Started: 2/20/2015

Boring Completed: 2/20/2015

Drill Rig: GC

Driller: DS

Project No.: MR155009

Exhibit: A-30

THIS BORING LOG IS NOT VALID IF SEPARATED FROM ORIGINAL REPORT. GEO LOG-DEPTH TO BOTTOM OF PAGE MR155009.GPJ TERRACON2012.GDT 3/16/15

# BORING LOG NO. 29

**PROJECT:** Pavement Rehabilitation -  
Village of Villa Park

**CLIENT:** Village of Villa Park IL  
Villa Park, Illinois

**SITE:** Multiple Streets  
Villa Park, Illinois

GRAPHIC LOG	LOCATION See Exhibit A-2	DEPTH (Ft.)	WATER LEVEL OBSERVATIONS	SAMPLE TYPE	RECOVERY (In.)	FIELD TEST RESULTS	HAND PENETROMETER, (psf)	SAMPLE NUMBER	WATER CONTENT (%)
	DEPTH								
0.6	<b>CONCRETE</b> , Approximately 7"								
1.0	<b>CRUSHED STONE AGGREGATE</b> , Approximately 5"								
7.5	<b>LEAN CLAY (CL)</b> , trace sand, gray, medium stiff to very stiff  to brown and gray	5		16		13-9-5 N=14	1500	1	30
		5		14		8-9-11 N=20	4000	2	21
							7000	3	20
	<b>Boring Terminated at 7.5 Feet</b>	10							

Stratification lines are approximate. In-situ, the transition may be gradual.

Hammer Type: Automatic SPT Hammer

Advancement Method:  
Hollow Stem Auger

See Exhibit A-1 for description of field procedures

Notes:

Abandonment Method:  
Boring backfilled with soil cuttings upon completion.

See Appendix B for description of laboratory procedures and additional data (if any).

See Appendix C for explanation of symbols and abbreviations.

**WATER LEVEL OBSERVATIONS**

*None, while drilling*

*None, after boring*



Boring Started: 2/20/2015

Boring Completed: 2/20/2015

Drill Rig: GC

Driller: DS

Project No.: MR155009

Exhibit: A-31

THIS BORING LOG IS NOT VALID IF SEPARATED FROM ORIGINAL REPORT. GEO LOG-DEPTH TO BOTTOM OF PAGE MR155009.GPJ TERRACON2012.GDT 3/16/15

# BORING LOG NO. 30

**PROJECT:** Pavement Rehabilitation -  
Village of Villa Park

**CLIENT:** Village of Villa Park IL  
Villa Park, Illinois

**SITE:** Multiple Streets  
Villa Park, Illinois

GRAPHIC LOG	LOCATION See Exhibit A-2	DEPTH (Ft.)	WATER LEVEL OBSERVATIONS	SAMPLE TYPE	RECOVERY (In.)	FIELD TEST RESULTS	HAND PENETROMETER, (psf)	SAMPLE NUMBER	WATER CONTENT (%)
	DEPTH								
0.7	<b>CONCRETE</b> , Approximately 6.5"								
1.5	<b>LEAN CLAY (CL)</b> , trace sand and gravel, brown and gray mottled, stiff to very stiff				15	12-9-7 N=16	3000	1	21
5.0	to brown	5			16	10-10-10 N=20	8000	2	21
7.5							7000	3	20
	<b>Boring Terminated at 7.5 Feet</b>								

Stratification lines are approximate. In-situ, the transition may be gradual.

Hammer Type: Automatic SPT Hammer

Advancement Method:  
Hollow Stem Auger

See Exhibit A-1 for description of field procedures

Notes:

Abandonment Method:  
Boring backfilled with soil cuttings upon completion.

See Appendix B for description of laboratory procedures and additional data (if any).

See Appendix C for explanation of symbols and abbreviations.

**WATER LEVEL OBSERVATIONS**

None, while drilling

None, after boring



135 Ambassador Drive  
Naperville, Illinois

Boring Started: 2/20/2015

Boring Completed: 2/20/2015

Drill Rig: GC

Driller: DS

Project No.: MR155009

Exhibit: A-32

THIS BORING LOG IS NOT VALID IF SEPARATED FROM ORIGINAL REPORT. GEO LOG-DEPTH TO BOTTOM OF PAGE MR155009.GPJ TERRACON2012.GDT 3/16/15

# BORING LOG NO. 31

**PROJECT:** Pavement Rehabilitation -  
Village of Villa Park

**CLIENT:** Village of Villa Park IL  
Villa Park, Illinois

**SITE:** Multiple Streets  
Villa Park, Illinois

GRAPHIC LOG	LOCATION See Exhibit A-2	DEPTH (Ft.)	WATER LEVEL OBSERVATIONS	SAMPLE TYPE	RECOVERY (In.)	FIELD TEST RESULTS	HAND PENETROMETER, (psf)	SAMPLE NUMBER	WATER CONTENT (%)
	DEPTH								
0.5	<b>CONCRETE</b> , Approximately 6.5"								
1.3	<b>ASPHALT</b> , Approximately 5"								
4.0	<b>LEAN CLAY (CL)</b> , trace sand and organics, dark gray, medium stiff  Sample 1: frozen	5		15		17-9-5 N=14	1000	1	32
7.5	<b>LEAN CLAY (CL)</b> , trace sand and gravel, brown and gray mottled, medium stiff to stiff  with sand	5		16		12-8-6 N=14	2000	2	33
7.5	<b>Boring Terminated at 7.5 Feet</b>						3500	3	26

Stratification lines are approximate. In-situ, the transition may be gradual.

Hammer Type: Automatic SPT Hammer

Advancement Method:  
Hollow Stem Auger

See Exhibit A-1 for description of field procedures

Notes:

Abandonment Method:  
Boring backfilled with soil cuttings upon completion.

See Appendix B for description of laboratory procedures and additional data (if any).

See Appendix C for explanation of symbols and abbreviations.

**WATER LEVEL OBSERVATIONS**

None, while drilling

None, after boring



135 Ambassador Drive  
Naperville, Illinois

Boring Started: 2/20/2015

Boring Completed: 2/20/2015

Drill Rig: GC

Driller: DS

Project No.: MR155009

Exhibit: A-33

THIS BORING LOG IS NOT VALID IF SEPARATED FROM ORIGINAL REPORT. GEO LOG-DEPTH TO BOTTOM OF PAGE MR155009.GPJ TERRACON2012.GDT 3/16/15

# BORING LOG NO. 32

**PROJECT:** Pavement Rehabilitation -  
Village of Villa Park

**CLIENT:** Village of Villa Park IL  
Villa Park, Illinois

**SITE:** Multiple Streets  
Villa Park, Illinois

GRAPHIC LOG	LOCATION See Exhibit A-2	DEPTH (Ft.)	WATER LEVEL OBSERVATIONS	SAMPLE TYPE	RECOVERY (In.)	FIELD TEST RESULTS	HAND PENETROMETER, (psf)	SAMPLE NUMBER	WATER CONTENT (%)
	<b>DEPTH</b>								
0.5	<b>CONCRETE</b> , Approximately 6.5"								
1.0	<b>CRUSHED STONE AGGREGATE</b> , Approximately 6"								
5.0	<b>FILL - SANDY GRAVEL</b> , trace sand, light gray, (crushed limestone)			15		43-39-19 N=58		1	9
7.5	<b>LEAN CLAY (CL)</b> , trace sand and gravel, brown and gray mottled, very stiff	5		15		11-9-7 N=16		2	27
7.5	<b>LEAN CLAY (CL)</b> , trace sand and gravel, brown and gray mottled, very stiff						4500	3	25
	<b>Boring Terminated at 7.5 Feet</b>								
		10							

Stratification lines are approximate. In-situ, the transition may be gradual.

Hammer Type: Automatic SPT Hammer

Advancement Method:  
Hollow Stem Auger

See Exhibit A-1 for description of field procedures

Notes:

Abandonment Method:  
Boring backfilled with soil cuttings upon completion.

See Appendix B for description of laboratory procedures and additional data (if any).

See Appendix C for explanation of symbols and abbreviations.

**WATER LEVEL OBSERVATIONS**

*None, while drilling*

*None, after boring*



Boring Started: 2/20/2015

Boring Completed: 2/20/2015

Drill Rig: GC

Driller: DS

Project No.: MR155009

Exhibit: A-34

THIS BORING LOG IS NOT VALID IF SEPARATED FROM ORIGINAL REPORT. GEO LOG-DEPTH TO BOTTOM OF PAGE MR155009.GPJ TERRACON2012.GDT 3/16/15

NOT FOR BID

**APPENDIX B**  
**LABORATORY TESTING**

NOT FOR BID

## Geotechnical Engineering Report

Pavement Evaluation ■ Multiple Streets, Villa Park, Illinois  
March 16, 2015 ■ Terracon Project No. MR155009



### Laboratory Testing

The soil samples obtained from the borings were tested in the laboratory to measure their natural water contents. A pocket penetrometer was used to help estimate the approximate unconfined compressive strength of selected cohesive samples. The test results are provided on the boring logs in Appendix A.

The soil samples were classified in the laboratory based on visual observation, texture, plasticity, and the limited laboratory testing described above. The soil descriptions presented on the boring logs are in general accordance with the enclosed General Notes (Exhibit C-1) and Unified Soil Classification System (USCS). The estimated USCS group symbols for native soils are shown on the boring logs, and a brief description of the USCS is included in this report (Exhibit C-2).

NOT FOR











NOT FOR BID

NOT FOR BID

**APPENDIX C**  
**SUPPORTING DOCUMENTS**

# GENERAL NOTES

## DESCRIPTION OF SYMBOLS AND ABBREVIATIONS

<b>SAMPLING</b>			<b>WATER LEVEL</b>		Water Initially Encountered	<b>FIELD TESTS</b>	(HP) Hand Penetrometer	
	<b>Auger</b>	<b>Split Spoon</b>			Water Level After a Specified Period of Time		(T) Torvane	
					Water Level After a Specified Period of Time		(b/f) Standard Penetration Test (blows per foot)	
	<b>Shelby Tube</b>	<b>Macro Core</b>		Water levels indicated on the soil boring logs are the levels measured in the borehole at the times indicated. Groundwater level variations will occur over time. In low permeability soils, accurate determination of groundwater levels is not possible with short term water level observations.			(PID) Photo-Ionization Detector	
							(OVA) Organic Vapor Analyzer	
<b>Ring Sampler</b>	<b>Rock Core</b>							
								
<b>Grab Sample</b>	<b>No Recovery</b>							

## DESCRIPTIVE SOIL CLASSIFICATION

Soil classification is based on the Unified Soil Classification System. Coarse Grained Soils have more than 50% of their dry weight retained on a #200 sieve; their principal descriptors are: boulders, cobbles, gravel or sand. Fine Grained Soils have less than 50% of their dry weight retained on a #200 sieve; they are principally described as clays if they are plastic, and silts if they are slightly plastic or non-plastic. Major constituents may be added as modifiers and minor constituents may be added according to the relative proportions based on grain size. In addition to gradation, coarse-grained soils are defined on the basis of their in-place relative density and fine-grained soils on the basis of their consistency.

## LOCATION AND ELEVATION NOTES

Unless otherwise noted, Latitude and Longitude are approximately determined using a hand-held GPS device. The accuracy of such devices is variable. Surface elevation data annotated with +/- indicates that no actual topographical survey was conducted to confirm the surface elevation. Instead, the surface elevation was approximately determined from topographic maps of the area.

<b>STRENGTH TERMS</b>	<b>RELATIVE DENSITY OF COARSE-GRAINED SOILS</b> (More than 50% retained on No. 200 sieve.) Density determined by Standard Penetration Resistance Includes gravels, sands and silts.			<b>CONSISTENCY OF FINE-GRAINED SOILS</b> (50% or more passing the No. 200 sieve.) Consistency determined by laboratory shear strength testing, field visual-manual procedures or standard penetration resistance		
	Descriptive Term (Density)	Standard Penetration or N-Value Blows/Ft.	Ring Sampler Blows/Ft.	Descriptive Term (Consistency)	Unconfined Compressive Strength, Qu, psf	Standard Penetration or N-Value Blows/Ft.
Very Loose	0 - 3	0 - 6	Very Soft	less than 500	0 - 1	< 3
Loose	4 - 9	7 - 18	Soft	500 to 1,000	2 - 4	3 - 4
Medium Dense	10 - 29	19 - 58	Medium-Stiff	1,000 to 2,000	4 - 8	5 - 9
Dense	30 - 50	59 - 98	Stiff	2,000 to 4,000	8 - 15	10 - 18
Very Dense	> 50	≥ 99	Very Stiff	4,000 to 8,000	15 - 30	19 - 42
			Hard	> 8,000	> 30	> 42

## RELATIVE PROPORTIONS OF SAND AND GRAVEL

Descriptive Term(s) of other constituents	Percent of Dry Weight
Trace	< 15
With	15 - 29
Modifier	> 30

## GRAIN SIZE TERMINOLOGY

Major Component of Sample	Particle Size
Boulders	Over 12 in. (300 mm)
Cobbles	12 in. to 3 in. (300mm to 75mm)
Gravel	3 in. to #4 sieve (75mm to 4.75 mm)
Sand	#4 to #200 sieve (4.75mm to 0.075mm)
Silt or Clay	Passing #200 sieve (0.075mm)

## RELATIVE PROPORTIONS OF FINES

Descriptive Term(s) of other constituents	Percent of Dry Weight
Trace	< 5
With	5 - 12
Modifier	> 12

## PLASTICITY DESCRIPTION

Term	Plasticity Index
Non-plastic	0
Low	1 - 10
Medium	11 - 30
High	> 30

# UNIFIED SOIL CLASSIFICATION SYSTEM

Criteria for Assigning Group Symbols and Group Names Using Laboratory Tests <sup>A</sup>				Soil Classification			
				Group Symbol	Group Name <sup>B</sup>		
<b>Coarse Grained Soils:</b> More than 50% retained on No. 200 sieve	<b>Gravels:</b> More than 50% of coarse fraction retained on No. 4 sieve	<b>Clean Gravels:</b> Less than 5% fines <sup>C</sup>	$Cu \geq 4$ and $1 \leq Cc \leq 3$ <sup>E</sup>	GW	Well-graded gravel <sup>F</sup>		
		<b>Gravels with Fines:</b> More than 12% fines <sup>C</sup>	Fines classify as ML or MH	GP	Poorly graded gravel <sup>F</sup>		
			Fines classify as CL or CH	GM	Silty gravel <sup>F,G,H</sup>		
		<b>Sands:</b> 50% or more of coarse fraction passes No. 4 sieve	<b>Clean Sands:</b> Less than 5% fines <sup>D</sup>	$Cu < 4$ and/or $1 > Cc > 3$ <sup>E</sup>	GC	Clayey gravel <sup>F,G,H</sup>	
	<b>Sands with Fines:</b> More than 12% fines <sup>D</sup>		$Cu \geq 6$ and $1 \leq Cc \leq 3$ <sup>E</sup>	SW	Well-graded sand <sup>I</sup>		
			$Cu < 6$ and/or $1 > Cc > 3$ <sup>E</sup>	SP	Poorly graded sand <sup>I</sup>		
	Fines classify as ML or MH		SM	Silty sand <sup>G,H,I</sup>			
		Fines classify as CL or CH	SC	Clayey sand <sup>G,H,I</sup>			
<b>Fine-Grained Soils:</b> 50% or more passes the No. 200 sieve	<b>Silts and Clays:</b> Liquid limit less than 50	<b>Inorganic:</b>	$PI > 7$ and plots on or above "A" line <sup>J</sup>	CL	Lean clay <sup>K,L,M</sup>		
			$PI < 4$ or plots below "A" line <sup>J</sup>	ML	Silt <sup>K,L,M</sup>		
		<b>Organic:</b>	Liquid limit - oven dried	< 0.75	OL	Organic clay <sup>K,L,M,N</sup>	
			Liquid limit - not dried		OH	Organic silt <sup>K,L,M,O</sup>	
	<b>Silts and Clays:</b> Liquid limit 50 or more	<b>Inorganic:</b>	PI plots on or above "A" line	CH	Fat clay <sup>K,L,M</sup>		
			PI plots below "A" line	MH	Elastic Silt <sup>K,L,M</sup>		
		<b>Organic:</b>	Liquid limit - oven dried	< 0.75	OH	Organic clay <sup>K,L,M,P</sup>	
			Liquid limit - not dried		OH	Organic silt <sup>K,L,M,Q</sup>	
		<b>Highly organic soils:</b> Primarily organic matter, dark in color, and organic odor				PT	Peat

<sup>A</sup> Based on the material passing the 3-inch (75-mm) sieve

<sup>B</sup> If field sample contained cobbles or boulders, or both, add "with cobbles or boulders, or both" to group name.

<sup>C</sup> Gravels with 5 to 12% fines require dual symbols: GW-GM well-graded gravel with silt, GW-GC well-graded gravel with clay, GP-GM poorly graded gravel with silt, GP-GC poorly graded gravel with clay.

<sup>D</sup> Sands with 5 to 12% fines require dual symbols: SW-SM well-graded sand with silt, SW-SC well-graded sand with clay, SP-SM poorly graded sand with silt, SP-SC poorly graded sand with clay

$$^E Cu = D_{60}/D_{10} \quad Cc = \frac{(D_{30})^2}{D_{10} \times D_{60}}$$

<sup>F</sup> If soil contains  $\geq 15\%$  sand, add "with sand" to group name.

<sup>G</sup> If fines classify as CL-ML, use dual symbol GC-GM, or SC-SM.

<sup>H</sup> If fines are organic, add "with organic fines" to group name.

<sup>I</sup> If soil contains  $\geq 15\%$  gravel, add "with gravel" to group name.

<sup>J</sup> If Atterberg limits plot in shaded area, soil is a CL-ML, silty clay.

<sup>K</sup> If soil contains 15 to 29% plus No. 200, add "with sand" or "with gravel," whichever is predominant.

<sup>L</sup> If soil contains  $\geq 30\%$  plus No. 200 predominantly sand, add "sandy" to group name.

<sup>M</sup> If soil contains  $\geq 30\%$  plus No. 200, predominantly gravel, add "gravelly" to group name.

<sup>N</sup>  $PI \geq 4$  and plots on or above "A" line.

<sup>O</sup>  $PI < 4$  or plots below "A" line.

<sup>P</sup> PI plots on or above "A" line.

<sup>Q</sup> PI plots below "A" line.

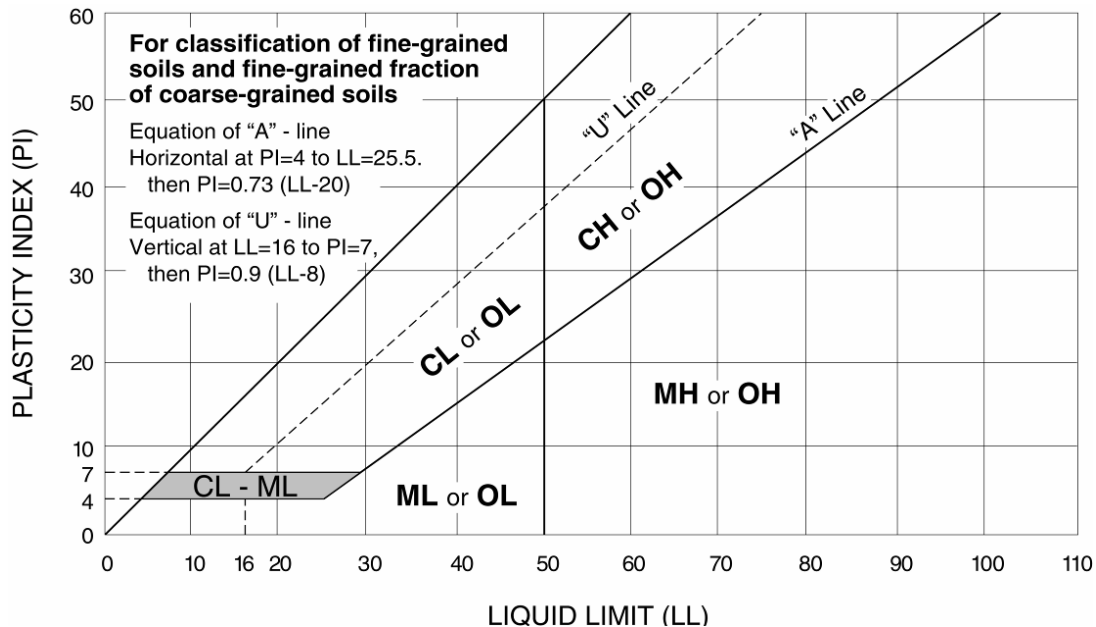

NOT FOR BID