

COVER SHEET

Proposal Submitted By:

Contractor's Name			
Contractor's Address	City	State	Zip Code

STATE OF ILLINOIS		
Local Public Agency	County	Section Number
Village of Villa Park	DuPage	25-00104-00-RS
Route(s) (Street/Road Name)	Type of Funds	
Highland Avenue	MFT	

Proposal Only Proposal and Plans Proposal only, plans are separate

Submitted/Approved
For Local Public Agency:

For a County and Road District Project
Submitted/Approved
Highway Commissioner Signature & Date
Submitted/Approved
County Engineer/Superintendent of Highways Signature & Date

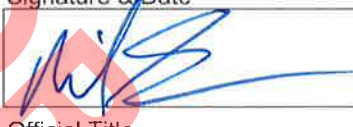
For a Municipal Project
Submitted/Approved/Passed
Signature & Date
 8/12/25
Official Title
Director of Public Works

Department of Transportation
Released for bid based on limited review
Regional Engineer Signature & Date

Note: All proposal documents, including Proposal Guaranty Checks or Proposal Bid Bonds, should be stapled together to prevent loss when bids are processed.



Emily A. Druckrey
8/12/2025

Local Public Agency	County	Section Number	Route(s) (Street/Road Name)
Village of Villa Park	DuPage	25-00104-00-RS	Highland Avenue

NOTICE TO BIDDERS

Sealed proposals for the project described below will be received at the office of via Quest CDN (Project #9807376)

https://www.questcdn.com Name of Office
until 10:00 AM on 08/28/25
Time Date

Sealed proposals will be opened and read publicly at the office of via Teams Conference Meeting ID: 272 713 055 350 4

Passcode: nh66az7S Name of Office
at 10:00 AM on 08/28/25
Time Date

DESCRIPTION OF WORK

Location	Project Length
Highland Avenue from Princeton Avenue to Villa Avenue	2,918 ft (0.55 mi)

Proposed Improvement
 Roadway milling and resurfacing, driveway removal and replacement, intermittent curb and gutter removal and replacement, ADA ramps with detectable warnings, pavement patching as needed, drainage and utility structure adjustments or reconstructions with new frame and lid/grate, and landscaping.

1. Plans and proposal forms will be available in the office of
 Village of Villa Park
 20 S. Ardmore Avenue
 Villa Park, IL 60181

2. Prequalification
 If checked, the 2 apparent as read low bidders must file within 24 hours after the letting an "Affidavit of Availability" (Form BC 57) in triplicate, showing all uncompleted contracts awarded to them and all low bids pending award for Federal, State, County, Municipal and private work. One original shall be filed with the Awarding Authority and two originals with the IDOT District Office.
3. The Awarding Authority reserves the right to waive technicalities and to reject any or all proposals as provided in BLRS Special Provision for Bidding Requirements and Conditions for Contract Proposals.
4. The following BLR Forms shall be returned by the bidder to the Awarding Authority:
 - a. Local Public Agency Formal Contract Proposal (BLR 12200)
 - b. Schedule of Prices (BLR 12201)
 - c. Proposal Bid Bond (BLR 12230) (if applicable)
 - d. Apprenticeship or Training Program Certification (BLR 12325) (do not use for project with Federal funds.)
 - e. Affidavit of Illinois Business Office (BLR 12326) (do not use for project with Federal funds)
5. The quantities appearing in the bid schedule are approximate and are prepared for the comparison of bids. Payment to the Contractor will be made only for the actual quantities of work performed and accepted or materials furnished according to the contract. The scheduled quantities of work to be done and materials to be furnished may be increased, decreased or omitted as hereinafter provided.
6. Submission of a bid shall be conclusive assurance and warranty the bidder has examined the plans and understands all requirements for the performance of work. The bidder will be responsible for all errors in the proposal resulting from failure or neglect to conduct an in depth examination. The Awarding Authority will, in no case, be responsible for any costs, expenses, losses or changes in anticipated profits resulting from such failure or neglect of the bidder.
7. The bidder shall take no advantage of any error or omission in the proposal and advertised contract.
8. If a special envelope is supplied by the Awarding Authority, each proposal should be submitted in that envelope furnished by the Awarding Agency and the blank spaces on the envelope shall be filled in correctly to clearly indicate its contents. When an envelope other than the special one furnished by the Awarding Authority is used, it shall be marked to clearly indicate its contents. When sent by mail, the sealed proposal shall be addressed to the Awarding Authority at the address and in care of the official in whose office the bids are to be received. All proposals shall be filed prior to the time and at the place specified in the Notice to Bidders. Proposals received after the time specified will be returned to the bidder unopened.
9. Permission will be given to a bidder to withdraw a proposal if the bidder makes the request in writing or in person before the time for opening proposals.

Local Public Agency	County	Section Number	Route(s) (Street/Road Name)
Village of Villa Park	DuPage	25-00104-00-RS	Highland Avenue

PROPOSAL

1. Proposal of _____ Contractor's Name _____

Contractor's Address _____

2. The plans for the proposed work are those prepared by TranSystems and approved by the Department of Transportation on _____

3. The specifications referred to herein are those prepared by the Department of Transportation and designated as "Standard Specifications for Road and Bridge Construction" and the " Supplemental Specifications and Recurring Special Provisions" thereto, adopted and in effect on the date of invitation for bids.

4. The undersigned agrees to accept, as part of the contract, the applicable Special Provisions indicated on the "Check Sheet for Recurring Special Provisions" contained in this proposal.

5. The undersigned agrees to complete the work within _____ working days or by 11/21/25 unless additional time is granted in accordance with the specifications.

6. The successful bidder at the time of execution of the contract will be required to deposit a contract bond for the full amount of the award. When a contract bond is not required, the proposal guaranty check will be held in lieu thereof. If this proposal is accepted and the undersigned fails to execute a contract and contract bond as required, it is hereby agreed that the Bid Bond of check shall be forfeited to the Awarding Authority.

7. Each pay item should have a unit price and a total price. If no total price is shown or if there is a discrepancy between the products of the unit price multiplied by the quantity, the unit price shall govern. If a unit price is omitted, the total price will be divided by the quantity in order to establish a unit price. A bid may be declared unacceptable if neither a unit price nor a total price is shown.

8. The undersigned submits herewith the schedule of prices on BLR 12201 covering the work to be performed under this contract.

9. The undersigned further agrees that if awarded the contract for the sections contained in the combinations on BLR 12201, the work shall be in accordance with the requirements of each individual proposal for the multiple bid specified in the Schedule for Multiple Bids below.

10. A proposal guaranty in the proper amount, as specified in BLRS Special Provision for Bidding Requirements and Conditions for Contract Proposals, will be required. Bid Bonds will be allowed as a proposal guaranty. Accompanying this proposal is either a bid bond, if allowed, on Department form BLR 12230 or a proposal guaranty check, complying with the specifications, made payable to: _____ Treasurer of Village of Villa Park .

The amount of the check is 5% of bid amount (_____).

Attach Cashier's Check or Certified Check Here

In the event that one proposal guaranty check is intended to cover two or more bid proposals, the amount must be equal to the sum of the proposal guaranties which would be required for each individual bid proposal. If the proposal guaranty check is placed in another bid proposal, state below where it may be found.

The proposal guaranty check will be found in the bid proposal for: Section Number 25-00104-00-RS .

Local Public Agency	County	Section Number	Route(s) (Street/Road Name)
Village of Villa Park	DuPage	25-00104-00-RS	Highland Avenue

CONTRACTOR CERTIFICATIONS

The certifications hereinafter made by the bidder are each a material representation of fact upon which reliance is placed should the Department enter into the contract with the bidder.

- Debt Delinquency.** The bidder or contractor or subcontractor, respectively, certifies that it is not delinquent in the payment of any tax administered by the Department of Revenue unless the individual or other entity is contesting, in accordance with the procedure established by the appropriate Revenue Act, its liability for the tax or the amount of the tax. Making a false statement voids the contract and allows the Department to recover all amounts paid to the individual or entity under the contract in a civil action.
- Bid-Rigging or Bid Rotating.** The bidder or contractor or subcontractor, respectively, certifies that it is not barred from contracting with the Department by reason of a violation of either 720 ILCS 5/33E-3 or 720 ILCS 5/33E-4.

A violation of section 33E-3 would be represented by a conviction of the crime of bid-rigging which, in addition to Class 3 felony sentencing, provides that any person convicted of this offense, or any similar offense of any state or the United States which contains the same elements as this offense shall be barred for 5 years from the date of conviction from contracting with any unit of State or local government. No corporation shall be barred from contracting with any unit of State or local government as a result of a conviction under this Section of any employee or agent of such corporation if the employee so convicted is no longer employed by the corporation: (1) it has been finally adjudicated not guilty or (2) if it demonstrates to the governmental entity with which it seeks to contract that entity finds that the commission of the offense was neither authorized, requested, commanded, nor performed by a director, officer or a high managerial agent on behalf of the corporation.

A violation of Section 33E-4 would be represented by a conviction of the crime of bid-rotating which, in addition to Class 2 felony sentencing, provides that any person convicted of this offense or any similar offense of any state or the United States which contains the same elements as this offense shall be permanently barred from contracting with any unit of State of Local government. No corporation shall be barred from contracting with any unit of State or Local government as a result of a conviction under this Section of any employee or agent of such corporation if the employee so convicted is no longer employed by the corporation and: (1) it has been finally adjudicated not guilty or (2) if it demonstrates to the governmental entity with which it seeks to contract and that entity finds that the commission of the offense was neither authorized, requested, commanded, nor performed by a director, officer or a high managerial agent on behalf of the corporation.

- Bribery.** The bidder or contractor or subcontractor, respectively, certifies that, it has not been convicted of bribery or attempting to bribe an officer or employee of the State of Illinois or any unit of local government, nor has the firm made an admission of guilt of such conduct which is a matter or record, nor has an official, agent, or employee of the firm committed bribery or attempted bribery on behalf of the firm and pursuant to the direction or authorization of a responsible official of the firm.
- Interim Suspension or Suspension.** The bidder or contractor or subcontractor, respectively, certifies that it is not currently under a suspension as defined in Subpart I of Title 44 Subtitle A Chapter III Part 6 of the Illinois Administrative code. Furthermore, if suspended prior to completion of this work, the contract or contracts executed for the completion of this work may be canceled.

Local Public Agency	County	Section Number	Route(s) (Street/Road Name)
Village of Villa Park	DuPage	25-00104-00-RS	Highland Avenue

SIGNATURES

(If an individual)

Bidder Signature & Date

Business Address

City

State

Zip Code

(If a partnership)

Firm Name

Signature & Date

Title

Business Address

City

State

Zip Code

Insert the Names and Addresses of all Partners

(If a corporation)

Corporate Name

Signature & Date

Title

Business Address

City

State

Zip Code

Insert Names of Officers

President

NOT FOR BID

Attest:

Secretary

Secretary

Treasurer

NOT FOR BID



Schedule of Prices



Contractor's Name

Contractor's Address

Local Public Agency

Route(s) (Street/Road Names)

City

State

Zip Code

County

Section Number

Schedule for Multiple Bids

Combination Letter	Section Included in Combinations	Total

Schedule for Single Bid

(For complete information covering these items, see plans and specifications.)

Item Number	Items	Unit	Quantity	Unit Price	Total
1	TRENCH BACKFILL	CU YD	15		
2	TOPSOIL FURNISH AND PLACE, 4"	SQ YD	793		
3	SODDING, SALT TOLERANT	SQ YD	793		
4	INLET FILTERS	EACH	31		
5	AGGREGATE BASE COURSE, TYPE B 4"	SQ YD	1,375		
6	BITUMINOUS MATERIALS (TACK COAT)	POUND	6,347		
7	LONGITUDINAL JOINT SEALANT	FOOT	2,918		
8	HOT-MIX ASPHALT SURFACE REMOVAL - BUTT JOINT	SQ YD	180		
9	POLYMERIZED HOT-MIX ASPHALT BINDER COURSE, IL-4.75, N50	TON	530		
10	HOT-MIX ASPHALT SURFACE COURSE, IL-9.5, MIX "D", N50	TON	793		
11	PROTECTIVE COAT	SQ YD	1,202		
12	PORTLAND CEMENT CONCRETE DRIVEWAY PAVEMENT, 6 INCH	SQ YD	251		
13	PORTLAND CEMENT CONCRETE SIDEWALK 5 INCH	SQ FT	3,901		
14	DETECTABLE WARNINGS	SQ FT	230		
15	HOT-MIX ASPHALT SURFACE REMOVAL, 2 1/2"	SQ YD	9,229		
16	DRIVEWAY PAVEMENT REMOVAL	SQ YD	345		
17	COMBINATION CURB AND GUTTER REMOVAL	FOOT	2,237		
18	SIDEWALK REMOVAL	SQ FT	4,826		
19	CLASS D PATCHES, 6 INCH	SQ YD	680		
20	STORM SEWERS, CLASS A, TYPE 1 12"	FOOT	18		
21	STORM SEWER REMOVAL 12"	FOOT	17		

Local Public Agency

Village of Villa Park

County

DuPage

Section Number

Route(s) (Street/Road Names)

Item Number	Items	Unit	Quantity	Unit Price	Total
22	INLETS, TYPE A	EACH	4		
23	INLETS TO BE RECONSTRUCTED	EACH	3		
24	FRAMES AND GRATES, TYPE 11	EACH	6		
25	FRAMES AND LIDS, TYPE 1, OPEN LID	EACH	1		
26	FRAMES AND LIDS, TYPE 1, CLOSED LID	EACH	3		
27	REMOVING CATCH BASINS	EACH	1		
28	COMBINATION CONCRETE CURB AND GUTTER, TYPE B-6.12 (SPECIAL)	FOOT	2,237		
29	CONSTRUCTION LAYOUT (SPECIAL)	L SUM	1		
30	TEMPORARY ACCESS (PRIVATE ENTRANCE)	EACH	17		
31	HOT-MIX ASPHALT DRIVEWAY PAVEMENT, 4"	SQ YD	72		
32	PROPOSED STORM SEWER CONNECTION TO EXISTING MANHOLE	EACH	2		
33	FRAMES AND LIDS TO BE ADJUSTED (SPECIAL)	EACH	23		
34	TRAFFIC CONTROL AND PROTECTION, (SPECIAL)	L SUM	1		
35	TEMPORARY INFORMATION SIGNING	SQ FT	416		
36	DRAINAGE STRUCTURES TO BE ADJUSTED	EACH	10		
37	STORM SEWERS, TYPE 1, WATER MAIN QUALITY PIPE, 12"	FOOT	21		
38	PRE-CONSTRUCTION VIDEO RECORDING	L SUM	1		
Bidder's Total Proposal					

1. Each pay item should have a unit price and a total price.
2. If no total price is shown or if there is a discrepancy between the product of the unit price multiplied by the quantity, the unit price shall govern.
3. If a unit price is omitted, the total price will be divided by the quantity in order to establish a unit price.
4. A bid may be declared unacceptable if neither a unit price or total price is shown.



Local Public Agency Proposal Bid Bond

Local Public Agency: Village of Villa Park; County: DuPage; Section Number: 25-00104-00-RS

WE, _____ as PRINCIPAL, and _____ as SURETY, are held jointly, severally and firmly bound unto the above Local Public Agency (hereafter referred to as "LPA") in the penal sum of 5% of the total bid price, or for the amount specified in the proposal documents in effect on the date of invitation for bids, whichever is the lesser sum. We bind ourselves, our heirs, executors, administrators, successors, and assigns, jointly pay to the LPA this sum under the conditions of this instrument.

WHEREAS THE CONDITION OF THE FOREGOING OBLIGATION IS SUCH that, the said PRINCIPAL is submitting a written proposal to the LPA acting through its awarding authority for the construction of the work designated as the above section.

THEREFORE if the proposal is accepted and a contract awarded to the PRINCIPAL by the LPA for the above designated section and the PRINCIPAL shall within fifteen (15) days after award enter into a formal contract, furnish surety guaranteeing the faithful performance of the work, and furnish evidence of the required insurance coverage, all as provided in the "Standard Specifications for Road and Bridge Construction" and applicable Supplemental Specifications, then this obligation shall become void; otherwise it shall remain in full force and effect.

IN THE EVENT the LPA determines the PRINCIPAL has failed to enter into a formal contract in compliance with any requirements set forth in the preceding paragraph, then the LPA acting through its awarding authority shall immediately be entitled to recover the full penal sum set out above, together with all court costs, all attorney fees, and any other expense of recovery.

IN TESTIMONY WHEREOF, the said PRINCIPAL and the said SURETY have caused this instrument to be signed by their respective officers this _____ Day of _____ Month and Year

Principal signature section with fields for Company Name, Signature & Date, and Title.

(If Principal is a joint venture of two or more contractors, the company names, and authorized signatures of each contractor must be affixed.)

Surety signature section with fields for Name of Surety and Signature of Attorney-in-Fact Signature & Date.

STATE OF IL
COUNTY OF

I _____, a Notary Public in and for said county do hereby certify that

(Insert names of individuals signing on behalf of PRINCIPAL & SURETY)

who are each personally known to me to be the same persons whose names are subscribed to the foregoing instrument on behalf of PRINCIPAL and SURETY, appeared before me this day in person and acknowledged respectively, that they signed and delivered said instruments as their free and voluntary act for the uses and purposes therein set forth.

Given under my hand and notarial seal this _____ Day of _____ Month and Year

(SEAL, if required by the LPA)

Notary Public Signature & Date field

Date commission expires _____

Local Public Agency

County

Section Number

Village of Villa Park

DuPage

25-00104-00-RS

ELECTRONIC BID BOND

Electronic bid bond is allowed (box must be checked by LPA if electronic bid bond is allowed)

The Principal may submit an electronic bid bond, in lieu of completing the above section of the Proposal Bid Bond Form. By providing an electronic bid bond ID code and signing below, the Principal is ensuring the identified electronic bid bond has been executed and the Principal and Surety are firmly bound unto the LPA under the conditions of the bid bond as shown above. (If PRINCIPAL is a joint venture of two or more contractors, an electronic bid bond ID code, company/Bidder name title and date must be affixed for each contractor in the venture.)

Electronic Bid Bond ID Code

--	--	--	--	--	--	--	--	--	--	--	--	--	--	--	--	--	--	--	--

Company/Bidder Name

--

Signature & Date

--

Title

--

NOT FOR BID

Instructions for BLR 12230

Note: The instructions should not be included when the form is submitted.

This form shall be used if the Local Public Agency (LPA) allows a bid bond as a Proposal Guaranty for all bid submissions on Motor Fuel Tax (MFT) or State funded contracts, deliver/install proposals and material proposals. See the Bureau of Local Roads and Streets Manual (BLRS) Chapter 12 for more information.

When filling out this form electronically, once a field is initially completed, fields requiring the same information will be auto-populated.

Local Public Agency	Insert the name of the LPA soliciting bids for the project.
County	Insert the name of the County in which the LPA is located.
Section Number	Insert the section number assigned to this project without dashes.
Principal Name and Address	Insert the names(s) and address(es) of the principal(s) of the company submitting the bid.
Surety Name and Address	Insert the name and address of the surety company providing the bid bond
Day	Insert the day of the month.
Month and Year	Insert the month and year.
Company Name	Insert the company's name that is submitting the bid.
By:	The authorized company officer shall sign and date here and insert their title.
Company Name	Insert the other company's name if bidder is a joint venture.
By:	If the bid is a joint venture, the authorized company officer of the joint bidder will sign here, and insert their title.
Name of Surety	Insert the name of the surety company providing the bid bond. This must be completed by the surety.
By: (Attorney-in-fact)	The attorney-in-fact shall sign and date here. This must be completed by the surety.
State of	Insert the name of the state where the signer(s) personally appeared before the notary public.
County of	Insert the name of the county where the signer(s) personally appeared before the notary public.
Name of Notary Public	Insert the name of notary public. Insert the names of the individuals signing on behalf of the principal and surety.
Day	Insert the day of the month the notary public signed and sealed this document.
Month and Year	Insert the month and year the notary public signed and sealed this document.
Commission Expires	Insert the date the notary public's commission expires. This is to be completed by the notary public.
Notary Public	The notary public must sign here and place their seal.
Electronic Bid Bond	Check the designated box if an electronic bid bond is allowed by the LPA awarding authority. The awarding authority is responsible for checking the box.
Electronic Bid Bond ID Code	Insert the electronic bid bond identification number for IDOT's approved surety company list.
Company/Bidder Name	Insert the company/bidder name (multiple names if a joint venture).
Signature and Title	The authorized company officer(s) must sign and date here, and insert his/her title(s). (Multiple signatures are required if a joint venture.)

A minimum of four (4) signed originals must be submitted to the Regional Engineer's District office.

Following the Regional Engineer's approval, distribution will be as follows:

- Local Public Agency Clerk (2)
- Engineer (Municipal, Consultant or County)
- District File

Local Public Agency	County	Street Name/Road Name	Section Number
Village of Villa Park	DuPage	Various	25-00104-00-RS

All contractors are required to complete the following certification

- For this contract proposal or for all bidding groups in this deliver and install proposal.
- For the following deliver and install bidding groups in this material proposal.

Illinois Department of Transportation policy, adopted in accordance with the provisions of the Illinois Highway Code, requires this contract to be awarded to the lowest responsive and responsible bidder. The award decision is subject to approval by the Department. In addition to all other responsibility factors, this contract or deliver and install proposal requires all bidders and all bidder's subcontractors to disclose participation in apprenticeship or training programs that are (1) approved by and registered with the United States Department of Labor's Bureau of Apprenticeship and Training, and (2) applicable to the work of the above indicated proposals or groups. Therefore, all bidders are required to complete the following certification:

1. Except as provided in paragraph 4 below, the undersigned bidder certifies that it is a participant, either as an individual or as part of a group program, in an approved apprenticeship or training program applicable to each type of work or craft that the bidder will perform with its own employees.
2. The undersigned bidder further certifies, for work to be performed by subcontract, that each of its subcontractors either (A) is, at the time of such bid, participating in an approved, applicable apprenticeship or training program; or (B) will, prior to commencement of performance of work pursuant to this contract, establish participation in an approved apprenticeship or training program applicable to the work of the subcontract.
3. The undersigned bidder, by inclusion in the list in the space below, certifies the official name of each program sponsor holding the Certificate of Registration for all of the types of work or crafts in which the bidder is a participant and that will be performed with the bidder's employees. Types of work or craft that will be subcontracted shall be included and listed as subcontract work. The list shall also indicate any type of work or craft job category for which there is no applicable apprenticeship or training program available.

4. Except for any work identified above, if any bidder or subcontractor shall perform all or part of the work of the contract or deliver and install proposal solely by individual owners, partners or members and not by employees to whom the payment of prevailing rates of wages would be required, check the following box, and identify the owner/operator workforces and positions of ownership.

The requirements of this certification and disclosure are a material part of the contract, and the contractor shall require this certification provision to be included in all approved subcontracts. The bidder is responsible for making a complete report and shall make certain that each type of work or craft job category that will be utilized on the project is accounted for and listed. The Department at any time before or afterward may require the production of a copy of each applicable Certificate of Registration issued by the United States Department of Labor evidencing such participation by the contractor and any or all of its subcontractors. In order to fulfill the participation requirement, it shall not be necessary that any applicable program sponsor be currently taking or that it will take applications for apprenticeship, training or employment during the performance of the work of this contract or deliver and install proposal.

Bidder	Signature & Date		
<div style="border: 1px solid black; height: 20px;"></div>	<div style="border: 1px solid black; height: 40px;"></div>		
Title			
<div style="border: 1px solid black; height: 20px;"></div>			
Address	City	State	Zip Code
<div style="border: 1px solid black; height: 20px;"></div>	<div style="border: 1px solid black; height: 20px;"></div>	<div style="border: 1px solid black; height: 20px;"></div>	<div style="border: 1px solid black; height: 20px;"></div>

Instructions for BLR 12325 - Page 1 of 1

Instructions should not be included when the form is submitted.

This form shall be used by the Local Public Agency (LPA) for contract proposal or material proposal/deliver and install project. It must be completed by all bidders and submitted with their bids. This is not to be used for Federally Funded projects. See the Bureau of Local Roads and Streets Manual (BLRS) Chapter 12 for more information.

Local Public Agency	Insert the name of the LPA soliciting bids for the project.
County	Insert the name of the County in which the LPA is located.
Street Name/ Road Name	Insert the name of the street/road on which the project is located. For projects that include several streets or roads insert various.
Section Number	Insert the section number assigned to this project without dashes.
Box 1	Check this box if this is a contract proposal or if all groups are a deliver and install proposal.
Box 2	Check this box if there are only certain groups within the material proposal that require delivery and installation.
Groups	Insert the individual groups from the material proposal schedule of prices (BLR 12241) that require the bidder to deliver and install.
Training Programs	Insert the names of all the apprenticeship or training programs that the contractor or subcontractor participates in.
Ownership	Check this box if the bidder or subcontractor will perform all or part of the work by individual owners, partners, or members and not by employees covered by prevailing wages.
Owner/operator	Insert the name(s) and position(s) of the owner/operator, if the box from above has been checked.
Bidder	Insert the name of the individual bidder or company name of the bidder.
Address	Insert the address of the bidder.
Signature	The bidder must sign and date here.
Title	Insert the title of the bidder that signed above.

Distribution:

This form is to be included in the proposal packet, except for federally funded projects, completed by bidder and returned with bid. Upon execution of a formal contract this is to be submitted with the formal contract package to the Department. For a Material/Deliver and Install project this to be maintained by the LPA. Distribution will be as listed on BLR 12200, BLR 12320, BLR 12240.



Affidavit of Illinois Business Office

Local Public Agency	County	Street Name/Road Name	Section Number
Village of Villa Park	DuPage	Highland Avenue	25-00104-00-RS

I, _____ of _____, _____,
Name of Affiant City of Affiant State of Affiant
 being first duly sworn upon oath, state as follows:

1. That I am the _____ of _____.
Officer or Position Bidder
2. That I have personal knowledge of the facts herein stated.
3. That, if selected under the proposal described above, _____, will maintain a business office in the
Bidder
 State of Illinois, which will be located in _____ County, Illinois.
County
4. That this business office will serve as the primary place of employment for any persons employed in the construction contemplated by this proposal.
5. That this Affidavit is given as a requirement of state law as provided in Section 30-22(8) of the Illinois Procurement Code.

Signature & Date

Print Name of Affiant

Notary Public

State of IL
 County _____

Signed (or subscribed or attested) before me on _____ by _____
(date)

_____, authorized agent(s) of _____
(name/s of person/s)

Bidder

Notary Public Signature & Date

(SEAL)

My commission expires _____

Instructions BLR 12326 - Page 1 of 1

The instructions should not be included when the form is submitted.

This form shall be used for Local Public Agency (LPA) contract proposals and deliver and install proposals. It must be completed by all bidders and submitted with their bids. This is not to be used for Federally Funded projects. See the Bureau of Local Roads and Streets Manual (BLRS) Chapter 12 for more information.

Local Public Agency	Insert the name of the LPA soliciting bids for the project.
County	Insert the name of the County in which the LPA is located.
Street Name/Road Name	Insert the name of the street/road on which the project is located. For projects that include several streets or routes insert various.
Section Number	Insert the section number assigned to this project without dashes.
Name of Affiant	Insert the name of the Affiant.
City of Affiant	Insert the city of residence of the Affiant.
State of Affiant	Insert the State of residence of the Affiant.
Officer or Position	Insert the position held by the Affiant.
Bidder	Insert the bidder's company name.
Bidder	Insert the bidder's company name.
County of	Insert the name of the County the Affiant is in.
Signature	The Affiant must sign and date here.
Name of Affiant	Insert the name of the Affiant (typed or printed).
State	Insert the name of the state where the signer(s) personally appeared before the notary public.
County	Insert the name of the county where the signer(s) personally appeared before the notary public.
Date	Insert the date the notary witnessed the signature(s).
Name	Insert the name(s) of the Affiant.
Bidder	Insert the bidder's company name.
Notary Signature	The Notary must sign and seal here.
Date Commission Expires	The Notary must write the date their commission expires here.

Distribution:

Upon completion this document gets inserted into the Formal Contract Proposal (BLR 12200) or the Material Proposal/Deliver and Install Proposal (BLR 12240) and **must be** submitted with the contractor's bid.

Upon execution of a formal contract this form is to be submitted with the formal contract package to the Department. For a Material/Deliver and Install project this form is to be maintained by the LPA.



Bureau of Construction
2300 South Dirksen Parkway/Room 322
Springfield, IL 62764

Instructions: Complete this form by either typing or using black ink. "Authorization to Bid" will not be issued unless both sides of this form are completed in detail. Use additional forms as needed to list all work.

Part I. Work Under Contract

List below all work you have under contract as either a prime contractor or a subcontractor. It is required to include all pending low bids not yet awarded or rejected. In a joint venture, list only that portion of the work which is the responsibility of your company. The uncompleted dollar value is to be based upon the most recent engineer's or owners estimate, and must include work subcontracted to others. If no work is contracted, show NONE.

	1	2	3	4	Awards Pending	Accumulated Totals
Contract Number						
Contract With						
Estimated Completion Date						
Total Contract Price						
Uncompleted Dollar Value if Firm is the Prime Contractor						
Uncompleted Dollar Value if Firm is the Subcontractor						
Total Value of All Work						

Part II. Awards Pending and Uncompleted Work to be done with your own forces.

List below the uncompleted dollar value of work for each contract and awards pending to be completed with your own forces. All work subcontracted to others will be listed on the reverse of this form. In a joint venture, list only that portion of the work to be done by your company. If no work is contracted, show NONE.

Earthwork						
Portland Cement Concrete Paving						
HMA Plant Mix						
HMA Paving						
Clean & Seal Cracks/Joints						
Aggregate Bases, Surfaces						
Highway, R.R., Waterway Struc.						
Drainage						
Electrical						
Cover and Seal Coats						
Concrete Construction						
Landscaping						
Fencing						
Guardrail						
Painting						
Signing						
Cold Milling, Planning, Rotomilling						
Demolition						
Pavement Markings (Paint)						
Other Construction (List)						
Totals						

Disclosure of this information is REQUIRED to accomplish the statutory purpose as outlined in the "Illinois Procurement Code." Failure to comply will result in non-issuance of an "Authorization To Bid." This form has been approved by the State Forms Management Center.

Part III. Work Subcontracted to Others.

For each contract described in Part I, list all the work you have subcontracted to others.

	1	2	3	4	Awards Pending
Subcontractor					
Type of Work					
Subcontract Price					
Amount Uncompleted					
Subcontractor					
Type of Work					
Subcontract Price					
Amount Uncompleted					
Subcontractor					
Type of Work					
Subcontract Price					
Amount Uncompleted					
Subcontractor					
Type of Work					
Subcontract Price					
Amount Uncompleted					
Subcontractor					
Type of Work					
Subcontract Price					
Amount Uncompleted					
Total Uncompleted					

Notary

I, being duly sworn, do hereby declare this affidavit is a true and correct statement relating to ALL uncompleted contracts of the undersigned for Federal, State, County, City and private work, including ALL subcontract work, ALL pending low bids not yet awarded or rejected and ALL estimated completion dates.

Officer or Director

Title

Signature

Date

Company

Address

City

State

Zip Code

Subscribed and sworn to before me

this _____ day of _____, _____

(Signature of Notary Public)

My commission expires _____

(Notary Seal)

Add pages for additional contracts



Affidavit of Availability

For the Letting of

Bureau of Construction
2300 South Dirksen Parkway/Room 322
Springfield, IL 62764

Instructions: Complete this form by either typing or using black ink. "Authorization to Bid" will not be issued unless both sides of this form are completed in detail. Use additional forms as needed to list all work.

Part I. Work Under Contract

List below all work you have under contract as either a prime contractor or a subcontractor. It is required to include all pending low bids not yet awarded or rejected. In a joint venture, list only that portion of the work which is the responsibility of your company. The uncompleted dollar value is to be based upon the most recent engineer's or owners estimate, and must include work subcontracted to others. If no work is contracted, show NONE.

	1	2	3	4	Awards Pending	Accumulated Totals
Contract Number						
Contract With						
Estimated Completion Date						
Total Contract Price						
Uncompleted Dollar Value if Firm is the Prime Contractor						
Uncompleted Dollar Value if Firm is the Subcontractor						
Total Value of All Work						

Part II. Awards Pending and Uncompleted Work to be done with your own forces.

List below the uncompleted dollar value of work for each contract and awards pending to be completed with your own forces. All work subcontracted to others will be listed on the reverse of this form. In a joint venture, list only that portion of the work to be done by your company. If no work is contracted, show NONE.

Earthwork						
Portland Cement Concrete Paving						
HMA Plant Mix						
HMA Paving						
Clean & Seal Cracks/Joints						
Aggregate Bases, Surfaces						
Highway, R.R., Waterway Struc.						
Drainage						
Electrical						
Cover and Seal Coats						
Concrete Construction						
Landscaping						
Fencing						
Guardrail						
Painting						
Signing						
Cold Milling, Planning, Rotomilling						
Demolition						
Pavement Markings (Paint)						
Other Construction (List)						
Totals						

Disclosure of this information is REQUIRED to accomplish the statutory purpose as outlined in the "Illinois Procurement Code." Failure to comply will result in non-issuance of an "Authorization To Bid." This form has been approved by the State Forms Management Center.

Part III. Work Subcontracted to Others.

For each contract described in Part I, list all the work you have subcontracted to others.

	2	3	4	Awards Pending	1
Subcontractor					
Type of Work					
Subcontract Price					
Amount Uncompleted					
Subcontractor					
Type of Work					
Subcontract Price					
Amount Uncompleted					
Subcontractor					
Type of Work					
Subcontract Price					
Amount Uncompleted					
Subcontractor					
Type of Work					
Subcontract Price					
Amount Uncompleted					
Subcontractor					
Type of Work					
Subcontract Price					
Amount Uncompleted					
Total Uncompleted					

Notary

I, being duly sworn, do hereby declare this affidavit is a true and correct statement relating to ALL uncompleted contracts of the undersigned for Federal, State, County, City and private work, including ALL subcontract work, ALL pending low bids not yet awarded or rejected and ALL estimated completion dates.

Officer or Director

Title

Signature

Date

Company

Address

City

State

Zip Code

Subscribed and sworn to before me

this _____ day of _____, _____

(Signature of Notary Public)

My commission expires _____

(Notary Seal)

Add pages for additional contracts



Affidavit of Availability

For the Letting of

Bureau of Construction
2300 South Dirksen Parkway/Room 322
Springfield, IL 62764

Instructions: Complete this form by either typing or using black ink. "Authorization to Bid" will not be issued unless both sides of this form are completed in detail. Use additional forms as needed to list all work.

Part I. Work Under Contract

List below all work you have under contract as either a prime contractor or a subcontractor. It is required to include all pending low bids not yet awarded or rejected. In a joint venture, list only that portion of the work which is the responsibility of your company. The uncompleted dollar value is to be based upon the most recent engineer's or owners estimate, and must include work subcontracted to others. If no work is contracted, show NONE.

	1	2	3	4	Awards Pending	Accumulated Totals
Contract Number						
Contract With						
Estimated Completion Date						
Total Contract Price						
Uncompleted Dollar Value if Firm is the Prime Contractor						
Uncompleted Dollar Value if Firm is the Subcontractor						
Total Value of All Work						

Part II. Awards Pending and Uncompleted Work to be done with your own forces.

List below the uncompleted dollar value of work for each contract and awards pending to be completed with your own forces. All work subcontracted to others will be listed on the reverse of this form. In a joint venture, list only that portion of the work to be done by your company. If no work is contracted, show NONE.

Earthwork						
Portland Cement Concrete Paving						
HMA Plant Mix						
HMA Paving						
Clean & Seal Cracks/Joints						
Aggregate Bases, Surfaces						
Highway, R.R., Waterway Struc.						
Drainage						
Electrical						
Cover and Seal Coats						
Concrete Construction						
Landscaping						
Fencing						
Guardrail						
Painting						
Signing						
Cold Milling, Planning, Rotomilling						
Demolition						
Pavement Markings (Paint)						
Other Construction (List)						
Totals						

Disclosure of this information is REQUIRED to accomplish the statutory purpose as outlined in the "Illinois Procurement Code." Failure to comply will result in non-issuance of an "Authorization To Bid." This form has been approved by the State Forms Management Center.

Part III. Work Subcontracted to Others.

For each contract described in Part I, list all the work you have subcontracted to others.

	1	2	3	4	Awards Pending
Subcontractor					
Type of Work					
Subcontract Price					
Amount Uncompleted					
Subcontractor					
Type of Work					
Subcontract Price					
Amount Uncompleted					
Subcontractor					
Type of Work					
Subcontract Price					
Amount Uncompleted					
Subcontractor					
Type of Work					
Subcontract Price					
Amount Uncompleted					
Subcontractor					
Type of Work					
Subcontract Price					
Amount Uncompleted					
Total Uncompleted					

Notary

I, being duly sworn, do hereby declare this affidavit is a true and correct statement relating to ALL uncompleted contracts of the undersigned for Federal, State, County, City and private work, including ALL subcontract work, ALL pending low bids not yet awarded or rejected and ALL estimated completion dates.

Officer or Director

Title

Signature

Date

Company

Address

City

State

Zip Code

Subscribed and sworn to before me
this _____ day of _____, _____

(Signature of Notary Public)

My commission expires _____

(Notary Seal)

Add pages for additional contracts



Affidavit of Availability

For the Letting of

Bureau of Construction
2300 South Dirksen Parkway/Room 322
Springfield, IL 62764

Instructions: Complete this form by either typing or using black ink. "Authorization to Bid" will not be issued unless both sides of this form are completed in detail. Use additional forms as needed to list all work.

Part I. Work Under Contract

List below all work you have under contract as either a prime contractor or a subcontractor. It is required to include all pending low bids not yet awarded or rejected. In a joint venture, list only that portion of the work which is the responsibility of your company. The uncompleted dollar value is to be based upon the most recent engineer's or owners estimate, and must include work subcontracted to others. If no work is contracted, show NONE.

	1	2	3	4	Awards Pending	Accumulated Totals
Contract Number						
Contract With						
Estimated Completion Date						
Total Contract Price						
Uncompleted Dollar Value if Firm is the Prime Contractor						
Uncompleted Dollar Value if Firm is the Subcontractor						
Total Value of All Work						

Part II. Awards Pending and Uncompleted Work to be done with your own forces.

List below the uncompleted dollar value of work for each contract and awards pending to be completed with your own forces. All work subcontracted to others will be listed on the reverse of this form. In a joint venture, list only that portion of the work to be done by your company. If no work is contracted, show NONE.

Earthwork						
Portland Cement Concrete Paving						
HMA Plant Mix						
HMA Paving						
Clean & Seal Cracks/Joints						
Aggregate Bases, Surfaces						
Highway, R.R., Waterway Struc.						
Drainage						
Electrical						
Cover and Seal Coats						
Concrete Construction						
Landscaping						
Fencing						
Guardrail						
Painting						
Signing						
Cold Milling, Planning, Rotomilling						
Demolition						
Pavement Markings (Paint)						
Other Construction (List)						
Totals						

Disclosure of this information is REQUIRED to accomplish the statutory purpose as outlined in the "Illinois Procurement Code." Failure to comply will result in non-issuance of an "Authorization To Bid." This form has been approved by the State Forms Management Center.

Part III. Work Subcontracted to Others.

For each contract described in Part I, list all the work you have subcontracted to others.

	1	2	3	4	Awards Pending
Subcontractor					
Type of Work					
Subcontract Price					
Amount Uncompleted					
Subcontractor					
Type of Work					
Subcontract Price					
Amount Uncompleted					
Subcontractor					
Type of Work					
Subcontract Price					
Amount Uncompleted					
Subcontractor					
Type of Work					
Subcontract Price					
Amount Uncompleted					
Subcontractor					
Type of Work					
Subcontract Price					
Amount Uncompleted					
Total Uncompleted					

Notary

I, being duly sworn, do hereby declare this affidavit is a true and correct statement relating to ALL uncompleted contracts of the undersigned for Federal, State, County, City and private work, including ALL subcontract work, ALL pending low bids not yet awarded or rejected and ALL estimated completion dates.

Officer or Director

Title

Signature

Date

Company

Address

City

State

Zip Code

Subscribed and sworn to before me

this _____ day of _____, _____

(Signature of Notary Public)

My commission expires _____

(Notary Seal)

Add pages for additional contracts



Affidavit of Availability

For the Letting of

Bureau of Construction
2300 South Dirksen Parkway/Room 322
Springfield, IL 62764

Instructions: Complete this form by either typing or using black ink. "Authorization to Bid" will not be issued unless both sides of this form are completed in detail. Use additional forms as needed to list all work.

Part I. Work Under Contract

List below all work you have under contract as either a prime contractor or a subcontractor. It is required to include all pending low bids not yet awarded or rejected. In a joint venture, list only that portion of the work which is the responsibility of your company. The uncompleted dollar value is to be based upon the most recent engineer's or owners estimate, and must include work subcontracted to others. If no work is contracted, show NONE.

	1	2	3	4	Awards Pending	Accumulated Totals
Contract Number						
Contract With						
Estimated Completion Date						
Total Contract Price						
Uncompleted Dollar Value if Firm is the Prime Contractor						
Uncompleted Dollar Value if Firm is the Subcontractor						
Total Value of All Work						

Part II. Awards Pending and Uncompleted Work to be done with your own forces.

List below the uncompleted dollar value of work for each contract and awards pending to be completed with your own forces. All work subcontracted to others will be listed on the reverse of this form. In a joint venture, list only that portion of the work to be done by your company. If no work is contracted, show NONE.

Earthwork						
Portland Cement Concrete Paving						
HMA Plant Mix						
HMA Paving						
Clean & Seal Cracks/Joints						
Aggregate Bases, Surfaces						
Highway, R.R., Waterway Struc.						
Drainage						
Electrical						
Cover and Seal Coats						
Concrete Construction						
Landscaping						
Fencing						
Guardrail						
Painting						
Signing						
Cold Milling, Planning, Rotomilling						
Demolition						
Pavement Markings (Paint)						
Other Construction (List)						
Totals						

Disclosure of this information is REQUIRED to accomplish the statutory purpose as outlined in the "Illinois Procurement Code." Failure to comply will result in non-issuance of an "Authorization To Bid." This form has been approved by the State Forms Management Center.

Part III. Work Subcontracted to Others.

For each contract described in Part I, list all the work you have subcontracted to others.

	1	2	3	4	Awards Pending
Subcontractor					
Type of Work					
Subcontract Price					
Amount Uncompleted					
Subcontractor					
Type of Work					
Subcontract Price					
Amount Uncompleted					
Subcontractor					
Type of Work					
Subcontract Price					
Amount Uncompleted					
Subcontractor					
Type of Work					
Subcontract Price					
Amount Uncompleted					
Subcontractor					
Type of Work					
Subcontract Price					
Amount Uncompleted					
Total Uncompleted					

Notary

I, being duly sworn, do hereby declare this affidavit is a true and correct statement relating to ALL uncompleted contracts of the undersigned for Federal, State, County, City and private work, including ALL subcontract work, ALL pending low bids not yet awarded or rejected and ALL estimated completion dates.

Officer or Director

Title

Signature

Date

Company

Address

City

State

Zip Code

Subscribed and sworn to before me
this _____ day of _____, _____

(Signature of Notary Public)

My commission expires _____

(Notary Seal)



Local Public Agency	County	Section Number
Village of Villa Park	DuPage	25-00104-00-RS

The following Special Provision supplement the "Standard Specifications for Road and Bridge Construction", adopted

January 1, 2022, the latest edition of the "Manual on Uniform Traffic Control Devices for Streets and Highways", and the "Manual of Test Procedures of Materials" in effect on the date of invitation of bids, and the Supplemental Specification and Recurring Special Provisions indicated on the Check Sheet included here in which apply to and govern the construction of the above named section, and in case of conflict with any parts, or parts of said Specifications, the said Special Provisions shall take precedence and shall govern.

Highland Avenue from Princeton Avenue to Villa Avenue The project includes roadway milling and resurfacing, driveway removal and replacement, intermittent curb and gutter removal and replacement, ADA ramps with detectable warnings, pavement patching as needed, drainage and utility structure adjustments or reconstructions with new frame and lid/grate, and landscaping.

NOT FOR BID

Instructions for BLR 11310

This form shall be used as the starting paragraph for the special provision packet included in Federal Aid, Township Bridge (TBP) and Motor Fuel Tax (MFT) roadway improvement and maintenance projects. For more information see Chapter 11 of the Bureau of Local Roads and Street Manual (BLRS Manual).

NOT FOR BID

Local Public Agency	County	Section Number
Village of Villa Park	DuPage	25-00104-00-RS

Check this box for lettings prior to 01/01/2025

The Following Recurring Special Provisions Indicated By An "X" Are Applicable To This Contract And Are Included By Reference:

Recurring Special Provisions

<u>Check Sheet #</u>		<u>Page No.</u>
1	<input type="checkbox"/> Additional State Requirements for Federal-Aid Construction Contracts	79
2	<input type="checkbox"/> Subletting of Contracts (Federal-Aid Contracts)	82
3	<input type="checkbox"/> EEO	83
4	<input type="checkbox"/> Specific EEO Responsibilities Non Federal-Aid Contracts	93
5	<input type="checkbox"/> Required Provisions - State Contracts	98
6	<input type="checkbox"/> Asbestos Bearing Pad Removal	104
7	<input type="checkbox"/> Asbestos Waterproofing Membrane and Asbestos HMA Surface Removal	105
8	<input type="checkbox"/> Temporary Stream Crossings and In-Stream Work Pads	106
9	<input checked="" type="checkbox"/> Construction Layout Stakes	107
10	<input type="checkbox"/> Use of Geotextile Fabric for Railroad Crossing	110
11	<input type="checkbox"/> Subsealing of Concrete Pavements	112
12	<input type="checkbox"/> Hot-Mix Asphalt Surface Correction	116
13	<input type="checkbox"/> Pavement and Shoulder Resurfacing	118
14	<input type="checkbox"/> Patching with Hot-Mix Asphalt Overlay Removal	119
15	<input type="checkbox"/> Polymer Concrete	121
16	<input type="checkbox"/> Reserved	123
17	<input type="checkbox"/> Bicycle Racks	124
18	<input type="checkbox"/> Temporary Portable Bridge Traffic Signals	126
19	<input type="checkbox"/> Nighttime Inspection of Roadway Lighting	128
20	<input type="checkbox"/> English Substitution of Metric Bolts	129
21	<input type="checkbox"/> Calcium Chloride Accelerator for Portland Cement Concrete	130
22	<input type="checkbox"/> Quality Control of Concrete Mixtures at the Plant	131
23	<input checked="" type="checkbox"/> Quality Control/Quality Assurance of Concrete Mixtures	139
24	<input type="checkbox"/> Reserved	155
25	<input type="checkbox"/> Reserved	156
26	<input type="checkbox"/> Temporary Raised Pavement Markers	157
27	<input type="checkbox"/> Restoring Bridge Approach Pavements Using High-Density Foam	158
28	<input type="checkbox"/> Portland Cement Concrete Inlay or Overlay	161
29	<input type="checkbox"/> Portland Cement Concrete Partial Depth Hot-Mix Asphalt Patching	165
30	<input type="checkbox"/> Longitudinal Joint and Crack Patching	168
31	<input type="checkbox"/> Concrete Mix Design - Department Provided	170
32	<input type="checkbox"/> Station Numbers in Pavements or Overlays	171

The Following Local Roads And Streets Recurring Special Provisions Indicated By An "X" Are Applicable To This Contract And Are Included By Reference:

Local Roads And Streets Recurring Special Provisions

<u>Check Sheet #</u>		<u>Page No.</u>
LRS 1	Reserved	173
LRS 2	<input type="checkbox"/> Furnished Excavation	174
LRS 3	<input checked="" type="checkbox"/> Work Zone Traffic Control Surveillance	175
LRS 4	<input checked="" type="checkbox"/> Flaggers in Work Zones	176
LRS 5	<input checked="" type="checkbox"/> Contract Claims	177
LRS 6	<input checked="" type="checkbox"/> Bidding Requirements and Conditions for Contract Proposals	178
LRS 7	<input type="checkbox"/> Bidding Requirements and Conditions for Material Proposals	184
LRS 8	Reserved	190
LRS 9	<input type="checkbox"/> Bituminous Surface Treatments	191
LRS 10	Reserved	195
LRS 11	<input checked="" type="checkbox"/> Employment Practices	196
LRS 12	<input checked="" type="checkbox"/> Wages of Employees on Public Works	198
LRS 13	<input checked="" type="checkbox"/> Selection of Labor	200
LRS 14	<input type="checkbox"/> Paving Brick and Concrete Paver Pavements and Sidewalks	201
LRS 15	<input checked="" type="checkbox"/> Partial Payments	204
LRS 16	<input type="checkbox"/> Protests on Local Lettings	205
LRS 17	<input checked="" type="checkbox"/> Substance Abuse Prevention Program	206
LRS 18	<input type="checkbox"/> Multigrade Cold Mix Asphalt	207
LRS 19	<input type="checkbox"/> Reflective Crack Control Treatment	208

BDE SPECIAL PROVISIONS
For the August 1 and September 19, 2025 Lettings

The following special provisions indicated by a "check mark" are applicable to this contract and will be included by the Project Coordination and Implementation Section of the Bureau of Design & Environment (BDE).

File Name	#		Special Provision Title	Effective	Revised
80099	1	<input type="checkbox"/>	Accessible Pedestrian Signals (APS)	April 1, 2003	Jan. 1, 2022
80274	2	<input type="checkbox"/>	Aggregate Subgrade Improvement	April 1, 2012	April 1, 2022
80192	3	<input type="checkbox"/>	Automated Flagger Assistance Devices	Jan. 1, 2008	April 1, 2023
80173	4	<input type="checkbox"/>	Bituminous Materials Cost Adjustments	Nov. 2, 2006	Aug. 1, 2017
80426	5	<input type="checkbox"/>	Bituminous Surface Treatment with Fog Seal	Jan. 1, 2020	Jan. 1, 2022
* 80241	6	<input type="checkbox"/>	Bridge Demolition Debris	July 1, 2009	
* 50531	7	<input type="checkbox"/>	Building Removal	Sept. 1, 1990	Aug. 1, 2022
* 50261	8	<input type="checkbox"/>	Building Removal with Asbestos Abatement	Sept. 1, 1990	Aug. 1, 2022
80460	9	<input checked="" type="checkbox"/>	Cement, Finely Divided Minerals, Admixtures, Concrete, and Mortar	Jan. 1, 2025	
80384	10	<input checked="" type="checkbox"/>	Compensable Delay Costs	June 2, 2017	April 1, 2019
* 80198	11	<input type="checkbox"/>	Completion Date (via calendar days)	April 1, 2008	
* 80199	12	<input type="checkbox"/>	Completion Date (via calendar days) Plus Working Days	April 1, 2008	
80461	13	<input type="checkbox"/>	Concrete Barrier	Jan. 1, 2025	
80453	14	<input type="checkbox"/>	Concrete Sealer	Nov. 1, 2023	
80261	15	<input checked="" type="checkbox"/>	Construction Air Quality – Diesel Retrofit	June 1, 2010	Jan. 1, 2025
* 80029	16	<input type="checkbox"/>	Disadvantaged Business Enterprise Participation	Sept. 1, 2000	Jan. 2, 2025
80467	17	<input type="checkbox"/>	Erosion Control Blanket	Aug. 1, 2025	
80229	18	<input type="checkbox"/>	Fuel Cost Adjustment	April 1, 2009	Aug. 1, 2017
80452	19	<input type="checkbox"/>	Full Lane Sealant Waterproofing System	Nov. 1, 2023	
80447	20	<input type="checkbox"/>	Grading and Shaping Ditches	Jan. 1, 2023	
80433	21	<input type="checkbox"/>	Green Preformed Thermoplastic Pavement Markings	Jan. 1, 2021	Jan. 1, 2022
80456	22	<input type="checkbox"/>	Hot-Mix Asphalt	Jan. 1, 2024	Jan. 1, 2025
80446	23	<input checked="" type="checkbox"/>	Hot-Mix Asphalt - Longitudinal Joint Sealant	Nov. 1, 2022	Aug. 1, 2023
80438	24	<input type="checkbox"/>	Illinois Works Apprenticeship Initiative – State Funded Contracts	June 2, 2021	April 2, 2024
80450	25	<input type="checkbox"/>	Mechanically Stabilized Earth Retaining Walls	Aug. 1, 2023	Aug. 1, 2025
80464	26	<input type="checkbox"/>	Pavement Marking Inspection	April 1, 2025	
80468	27	<input checked="" type="checkbox"/>	Pavement Patching	Aug. 1, 2025	
80441	28	<input checked="" type="checkbox"/>	Performance Graded Asphalt Binder	Jan. 1, 2023	
80459	29	<input type="checkbox"/>	Preformed Plastic Pavement Marking	June 2, 2024	
* 34261	30	<input type="checkbox"/>	Railroad Protective Liability Insurance	Dec. 1, 1986	Jan. 1, 2022
80455	31	<input checked="" type="checkbox"/>	Removal and Disposal of Regulated Substances	Jan. 1, 2024	April 1, 2024
80445	32	<input type="checkbox"/>	Seeding	Nov. 1, 2022	
80457	33	<input type="checkbox"/>	Short Term and Temporary Pavement Markings	April 1, 2024	April 2, 2024
80462	34	<input type="checkbox"/>	Sign Panels and Appurtenances	Jan. 1, 2025	April 1, 2025
80469	35	<input type="checkbox"/>	Slope Wall	Aug. 1, 2025	
80448	36	<input type="checkbox"/>	Source of Supply and Quality Requirements	Jan. 2, 2023	
80340	37	<input type="checkbox"/>	Speed Display Trailer	April 2, 2014	Jan. 1, 2022
80127	38	<input type="checkbox"/>	Steel Cost Adjustment	April 2, 2004	Jan. 1, 2022
80397	39	<input type="checkbox"/>	Subcontractor and DBE Payment Reporting	April 2, 2018	
80391	40	<input type="checkbox"/>	Subcontractor Mobilization Payments	Nov. 2, 2017	April 1, 2019
80463	41	<input type="checkbox"/>	Submission of Bidders List Information	Jan. 2, 2025	Mar. 2, 2025
80437	42	<input type="checkbox"/>	Submission of Payroll Records	April 1, 2021	Nov. 2, 2023
80435	43	<input type="checkbox"/>	Surface Testing of Pavements – IRI	Jan. 1, 2021	Jan. 1, 2023
80465	44	<input type="checkbox"/>	Surveying Services	April 1, 2025	
80466	45	<input type="checkbox"/>	Temporary Rumble Strips	April 1, 2025	
80470	46	<input type="checkbox"/>	Traffic Signal Backplate	Aug. 1, 2025	
* 20338	47	<input type="checkbox"/>	Training Special Provisions	Oct. 15, 1975	Sept. 2, 2021
80429	48	<input type="checkbox"/>	Ultra-Thin Bonded Wearing Course	April 1, 2020	Jan. 1, 2022
80439	49	<input checked="" type="checkbox"/>	Vehicle and Equipment Warning Lights	Nov. 1, 2021	Nov. 1, 2022
80458	50	<input type="checkbox"/>	Waterproofing Membrane System	Aug. 1, 2024	
80302	51	<input type="checkbox"/>	Weekly DBE Trucking Reports	June 2, 2012	Jan. 2, 2025

80454	52	<input type="checkbox"/>	Wood Sign Support	Nov. 1, 2023	
80427	53	<input checked="" type="checkbox"/>	Work Zone Traffic Control Devices	Mar. 2, 2020	Jan. 1, 2025
* 80071	54	<input type="checkbox"/>	Working Days	Jan. 1, 2002	

Highlighted items indicate a new or revised special provision for the letting.

An * indicates the special provision requires additional information from the designer, which needs to be submitted separately. The Project Coordination and Implementation Section will then include the information in the applicable special provision.

The following special provisions are in the 2025 Supplemental Specifications and Recurring Special Provisions.

<u>File Name</u>	<u>Special Provision Title</u>	<u>New Location(s)</u>	<u>Effective</u>	<u>Revised</u>
80434	Corrugated Plastic Pipe (Culvert and Storm Sewer)	Articles 542.03, 550.03, 1040.03, 1040.04(b), 1040.04(d) & 1040.08	Jan. 1, 2021	
80443	High Tension Cable Median Barrier Removal	Section 632	April 1, 2022	
80045	Material Transfer Device	Articles 406.03, 406.06(f), 406.13(b), 406.14 & 1102.02	Nov 15, 1999	Jan. 1, 2022
80410	Traffic Spotters	Article 701.13	Jan. 1, 2019	

NOT FOR BID



VILLAGE OF VILLA PARK

CONTRACT DOCUMENTS

FOR THE

HIGHLAND AVENUE – PRINCETON AVENUE TO VILLA AVENUE
ROADWAY RESURFACING PLANS

BID ADVERTISEMENT DATE – AUGUST 14, 2025

PREPARED BY

TRANSYSTEMS

**ADVERTISEMENT FOR BIDS
VILLAGE OF VILLA PARK**

**PROJECT: HIGHLAND AVENUE – PRINCETON AVENUE TO VILLA AVENUE
ROADWAY RESURFACING PLANS**

This project consists of milling and resurfacing, intermittent curb and gutter removal and replacement, driveway removal and replacement, ADA ramps with detectable warnings, pavement patching as needed, drainage and utility structure adjustments or reconstructions with new frame and lid/grate, and landscaping.

BID DEADLINE: AUGUST 28, 2025 AT 10:00 AM LOCAL TIME

The Village reserves the right to extend the Bid Deadline from this date and time to accept Bids submitted after the Bid Deadline, as the Village, in its sole discretion, determines is in the best interest of the Village.

NOTICE: Proposals for the **HIGHLAND AVENUE – PRINCETON AVENUE TO VILLA AVENUE ROADWAY RESURFACING PLANS** will be received electronically by the Village of Villa Park, Illinois, through QuestCDN at <https://www.questcdn.com> under **QuestCDN Project #9807376** until the Bid Deadline. Immediately thereafter, the proposals will be opened and read aloud via Microsoft Teams. Notwithstanding the foregoing, the Village reserves the right to defer, postpone, delay, or reschedule the Bid Opening for such time and to such date as the Village, in its sole discretion, determines is in the best interest of the Village. The Bid Opening Microsoft Teams meeting may be accessed as follows:

<https://teams.microsoft.com/> [Click here to join the meeting \[teams.microsoft.com\]](#)

Meeting ID: 272 713 055 350 4

Passcode: nh66az7S

Proposals shall be submitted in accordance with the Bidding Documents prepared by Michael Guerra.

BIDDER QUALIFICATIONS: Bidders, in submitting a Bid, shall comply with all applicable Federal, State and Local laws and requirements; shall provide documentation of that compliance in accordance with the requirements of the Contract Documents or as requested by the Village; and, in submitting a Bid, Bidders affirm that they are qualified under all applicable laws and requirements to do so, and agree to be bound by the determination of the Village as to Bidder's compliance and qualifications.

BID SECURITY: Bid security in the amount of not less than five percent (5%) of the Bid shall accompany each Bid in accordance with the Bidding Documents.

CONTRACT SECURITY: The Bidder to whom a Contract is awarded shall be required to furnish both a Performance Bond and a Payment Bond acceptable to the Village for one-hundred percent (100%) of the Contract Price, in accordance with the requirements of the Contract Documents.

REQUESTS FOR INFORMATION OR CLARIFICATION: All requests for information or clarification shall be submitted to the Village of Villa Park by email to engineering@invillapark.com. All responses that are provided to requests for information or clarification will be provided through QuestCDN at <https://www.questcdn.com> under **QuestCDN Project #9807376**.

The Village will accept requests for information or clarification submitted in accordance with the above requirements until **FRIDAY, AUGUST 22 AT NOON LOCAL TIME**. Requests for information or clarification received after such time will not be accepted and will receive no response. The requests for information response and/or Addendum deadline will be **TUESDAY, AUGUST 26 AT 5:00 PM LOCAL TIME**.

ADDENDA: The Village reserves the right to issue Addenda modifying the Bidding Documents at any time prior to the Bid Deadline. The foregoing notwithstanding, the Village will make a reasonable effort to issue no addenda after **TUESDAY, AUGUST 26 AT 5:00 PM LOCAL TIME**

RIGHTS RESERVED: The Village will select the lowest, most responsible bidder. The Village reserves the right to reject any or all Bids, to waive any informalities or technicalities in bidding, and to accept the Bid which best serves the interests of the Village. The Village shall, in its sole discretion, determine what does or does not constitute an informality or technicality, and, in submitting a Bid, Bidder agrees to be bound by that determination.

The Village may make such investigations as it deems necessary to determine the ability of the Bidder to perform the Work, and the Bidder shall furnish to the Village all such information and data for this purpose as the Village may request. The Village reserves the right to reject any Bid if the evidence submitted by, or investigation of, such Bidder fails to satisfy the Village that such Bidder is properly qualified to carry out the obligations of the Agreement and to complete the Work contemplated therein.

WAGE RATES: All applicable laws, ordinances, and the rules and regulations of all authorities having jurisdiction over construction of the PROJECT shall apply to the contract throughout.

Davis-Bacon Wage decisions are applicable to this project and are only superseded in instances by and where Illinois Prevailing Wages exceed Davis-Bacon in wage, fringe benefits, and/or trade stipulations (requirements). If this project does not start within ninety (90) days of contract award, the wage decisions applicable to the project shall be replaced with the Davis-Bacon Wage decisions that are current as of the date of contract award.

BIDDING DOCUMENTS: The Bidding Documents may be obtained from QuestCDN at <https://www.questcdn.com> under **QuestCDN Project #9807376** for a non-refundable fee of forty-two dollars (\$42.00). An active QuestCDN account and login are required. Questions or issues regarding the QuestCDN platform shall be directed to QuestCDN by phone at 952-233-1632 or by email at info@questcdn.com. Hard copies of bidding documents will not be made available. An electronic “Not for Bid” version of the bidding documents in Portable Document Format (PDF) will be available for download on the project page on the Village of Villa Park’s website at <https://www.invillapark.com>. This version of the bidding documents is for informational purposes only and may not be used for the preparation or submittal of a bid.

PUBLISHED BY AUTHORITY OF THE VILLAGE OF VILLA PARK, COUNTY OF DUPAGE, STATE OF ILLINOIS.

INDEX OF SPECIAL PROVISIONS

TITLE	PAGE NO.
SPECIAL PROVISIONS.....	8
DEFINITIONS	8
LOCATION OF PROJECT	8
DESCRIPTION OF PROJECT	8
GENERAL SPECIAL PROVISIONS.....	9
QUALIFICATIONS OF BIDDERS.....	9
BID PRICE LIMITATIONS.....	11
BIDS TO REMAIN SUBJECT TO ACCEPTANCE.....	11
INCREASED OR DECREASED QUANTITIES.....	11
FINAL INSPECTION.....	11
DATE OF MANUFACTURE	11
MATERIAL ORDERS.....	12
MATERIAL AND EQUIPMENT STORAGE	12
IRON, STEEL, COPPER, AND BRASS PRODUCTS.....	12
HOLIDAYS	12
PUBLIC CONVENIENCE AND SAFETY (D-1).....	13
USE OF FIRE HYDRANTS	13
INSURANCE	14
SUBCONTRACTING	14
PROGRESS SCHEDULE	14
WORKING HOURS	15
CONTRACT TIME	16
FAILURE TO COMPLETE THE WORK ON TIME.....	16
MONIES DUE TO OWNER.....	16

PARTIAL PAYMENTS	16
TREE CARE	17
TREE DAMAGE.....	17
BITUMINOUS MATERIALS	18
SAW CUTS	18
TEST STRIPS	18
DUST CONTROL WATERING.....	19
CONFLICTS WITH UTILITIES.....	19
PORTLAND CEMENT CONCRETE PAVEMENTS AND SIDEWALKS.....	19
MOBILIZATION.....	19
KEEPING ROADS OPEN TO TRAFFIC.....	19
ACCESS TO ADJACENT PROPERTIES.....	19
CONSTRUCTION NOTICES	20
PORTABLE TOILET	20
PROGRESS MEETINGS	20
OPERATION OF WATER DISTRIBUTION FACILITIES	21
CONSTRUCTION SAFETY AND HEALTH STANDARDS	21
MAINTENANCE WARRANTY.....	21
MAINTENANCE OF ROADWAYS (D1).....	22
RESPONSIBILITY FOR VANDALISM.....	22
EXCAVATION AND BACKFILLING OF DRAINAGE AND UTILITY STRUCTURES.....	22
SALVAGE AND DISPOSAL OF EXISTING MATERIALS.....	22
ADJUSTING RINGS	23
FRAMES, GRATES, AND LIDS	23
STORM STRUCTURES.....	24
PROTECTION OF EXISTING DRAINAGE FACILITIES DURING CONSTRUCTION.....	24

DROP HAMMERS24

AVAILABLE REPORTS25

ADJUSTMENTS AND RECONSTRUCTIONS (D1)26

DRAINAGE AND INLET PROTECTION UNDER TRAFFIC (D1)26

HOT-MIX ASPHALT BINDER AND SURFACE COURSE (D1).....30

HOT-MIX ASPHALT – MIXTURE DESIGN VERIFICATION AND PRODUCTION (D1).....37

STATUS OF UTILITIES (D-1)38

TRAFFIC CONTROL PLAN (D1)39

PAY ITEM SPECIAL PROVISIONS41

PAY ITEM #3 – SODDING, SALT TOLERANT41

PAY ITEM #4 – INLET FILTERS.....41

PAY ITEM #6 – BITUMINOUS MATERIALS (TACK COAT).....41

PAY ITEM #14 – DETECTABLE WARNINGS.....42

PAY ITEM #16 – DRIVEWAY PAVEMENT REMOVAL.....42

PAY ITEM #17 – COMBINATION CURB AND GUTTER REMOVAL43

PAY ITEM #18 – SIDEWALK REMOVAL.....43

PAY ITEM #19 – CLASS D PATCHES, 6 INCH.....44

PAY ITEM #20 – INLET44

PAY ITEM #24 – FRAMES AND GRATES, TYPE 11.....45

PAY ITEM #25 & #26 – FRAMES AND LIDS, TYPE 145

PAY ITEM #28 – COMBINATION CONCRETE CURB AND GUTTER, TYPE B-6.12 (SPECIAL)45

PAY ITEM #29 – CONSTRUCTION LAYOUT SPECIAL FOR RESURFACING WITH ADA AND
 STAND ALONE ADA (D1)47

PAY ITEM #31 – HOT-MIX ASPHALT DRIVEWAY PAVEMENT, 4”48

PAY ITEM #32 - PROPOSED STORM SEWER CONNECTION TO EXISTING MANHOLE49

PAY ITEM #33 – FRAMES AND LIDS TO BE ADJUSTED (SPECIAL).....49

PAY ITEM #34 – TRAFFIC CONTROL AND PROTECTION (SPECIAL)50

PAY ITEM #35 – TEMPORARY INFORMATION SIGNING50
PAY ITEM #36 – DRAINAGE STRUCTURES TO BE ADJUSTED.....51
PAY ITEM #37 - STORM SEWERS WATER MAIN QUALITY PIPE51
PAY ITEM #38 – PRE-CONSTRUCTION VIDEO RECORDING52

APPENDIX A

VILLAGE OF VILLA PARK ORDINANCE 3733

APPENDIX B

IRMA CONTRACTUAL INSURANCE GUIDELINES

APPENDIX C

BDE SPECIAL PROVISIONS

LR 107-4 – SPECIAL PROVISION FOR INSURANCE

LR 1030-2 – Special Provision for Local Quality Assurance/ Quality Management QC/QA

APPENDIX D

IDOT HIGHWAY STANDARDS

SPECIAL PROVISIONS

The following Special Provisions supplement the "Standard Specifications for Road and Bridge Construction," adopted January 1, 2022 (hereinafter referred to as the Standard Specifications); the "Supplemental Specifications and Recurring Special Provisions"; the latest edition of the "Illinois Manual on Uniform Traffic Control Devices for Streets and Highways"; the "Manual of Test Procedures for Materials" in effect on the date of invitation for bids; and the "Supplemental Specifications and Recurring Special Provisions" indicated on the Check Sheet included herein, which apply to and govern the construction of the Highland Avenue from Princeton Avenue to Villa Avenue, Resurfacing Plans within the Village of Villa Park, and in case of conflict with any part, or parts, of said specifications, the said Special Provisions shall take precedence and shall govern.

Highland Avenue from Princeton Avenue to Villa Avenue
Roadway Resurfacing Plans
Section 25-00104-00-RS
DuPage County

DEFINITIONS

Contractor. The individual, firm, partnership, joint venture, or corporation contracting with the Village of Villa Park for performance of prescribed work.

Department, Owner or Village. The Village of Villa Park, County of DuPage, State of Illinois.

Engineer. The Resident Engineer who is the authorized representative of the Village of Villa Park in immediate charge of the engineering details of a construction project.

LOCATION OF PROJECT

This project begins on Highland Avenue at Station 100+00.00, and extends in an easterly direction to just west of Villa Avenue at Station 130+84.71 with gaps at Ardmore Avenue and Cornell Avenue. The project is within the Village of Villa Park. The project gross length is 3,084.71 feet (0.584 miles) and net length is 2,917.71 feet (0.553 miles).

DESCRIPTION OF PROJECT

The proposed improvement consists of milling and resurfacing, intermittent curb and gutter removal and replacement, driveway removal and replacement, ADA ramps with detectable warnings, pavement patching as needed, drainage and utility structure adjustments or reconstructions with new frame and lid/grate, landscaping, and all incidental and collateral work necessary to complete the project as shown on the plans and as described herein.

GENERAL SPECIAL PROVISIONS

QUALIFICATIONS OF BIDDERS

Bidders shall comply with all applicable Federal, State, and local laws and requirements, and will further meet the qualifications prescribed in this and other applicable portions of these provisions.

Bidder, in submitting a Bid, certifies that Bidder is in compliance with all applicable Federal, State, and local laws and requirements, and that Bidder further meets the qualifications prescribed in this and other applicable portions of these provisions. Engineer's determination as to the compliance and qualifications of the Bidder will be final, and Bidder, in submitting a Bid, agrees to be bound by that determination.

Bidder, in submitting a Bid, certifies that Bidder is in compliance with the following requirements and qualifications. Bidder further certifies that Bidder is able to provide written evidence of Bidder's compliance with the following requirements and qualifications. Bidder shall, upon request by Engineer, submit such written evidence within five (5) calendar days of the Engineer's request, as well as any other written evidence which Engineer may deem necessary for the purpose of evaluating Bidder's qualifications.

- (a) Bidder shall be qualified to do business in the State of Illinois.
- (b) Bidder shall possess either a valid Federal Employer Tax Identification Number (FEIN) or a valid Social Security Number (SSN).
- (c) Bidder shall be able to provide a street address and description of the Bidder's place of business, and the mailing address of the business, if different from the street address.
- (d) Bidder shall be able to provide the number of years Bidder has been engaged in the contracting business under the present firm name, and the name of the state where incorporated.
- (e) Bidder shall be able to provide a list of the property and equipment available to the Bidder.
- (f) Bidder shall be able to provide a financial statement demonstrating that the Bidder has the financial resources to meet all obligations related to the Work.
- (g) Bidder shall maintain insurance policies with the coverages required by the Contract, and with the minimum limits of coverage required by the Contract. Bidder shall be able to provide current certificate(s) of insurance for the insurance policies held by Bidder, demonstrating that Bidder holds insurance policies with the coverages required by the contract, and with the minimum limits of coverage required by the Contract.
- (h) Bidder shall have constructed a minimum of three (3) projects of a similar nature in the immediate past five (5) years. Bidder shall be able to provide a list of all projects of a similar nature constructed by Bidder in the immediate past five (5) years, which list shall contain the minimum of three (3) such projects, which list shall provide a description and the location(s) of all such projects, and shall contain the Bidder's performance record and references, as well as the names and current contact information, including addresses and telephone numbers, of persons who acted as owners' representatives for those projects and who have knowledge of those projects, and whom Bidder agrees the Village may contact for the purpose of verifying Bidder's performance and references.
- (i) Bidder shall be able to provide a list of three (3) references (name, address and telephone number) with knowledge of the integrity and business practices of the bidder. Such references may not be persons who have been employed by Bidder as employees.

- (j) Bidder shall be able to provide a list of projects presently under Contract, the awarded Contract amount of each, the approximate adjusted Contract amount of each (if applicable), and the dollar amount or percent of completion of each.
- (k) Bidder shall be able to provide a list of Contracts which have resulted in lawsuits, whether against Bidder as a prime contractor, against Bidder as a subcontractor, or against Bidder as a party in any other capacity; or against subcontractors or suppliers performing work for Bidder or under Contract held by Bidder.
- (l) Bidder shall be able to provide a list of Contracts defaulted.
- (m) Bidder shall be able to provide a statement indicating whether or not Bidder has ever filed bankruptcy.
- (n) Bidder shall be able to provide a list of all officers of the firm, which list shall also indicate those officers who, while in the employ of the firm or in the employ of previous firms, were associated with Contracts which resulted in lawsuits, Contracts defaulted, or firms which filed for bankruptcy.
- (o) Bidder shall maintain personnel guaranteed to be employed in the responsible charge of the Work, which personnel possess sufficient technical experience to ensure the satisfactory completion of the Work. Bidder shall be able to provide the names and technical experience of such personnel, as well as statements as to whether the personnel have or have not performed satisfactorily on other contracts of like nature and magnitude or comparable difficulty at similar rate of progress.
- (p) Bidder shall be able to provide a list of subcontractors and suppliers anticipated to be employed by Bidder for the purpose of completing the Work, including the firm name, street address and description of place of business; mailing address of business (if different); phone, fax and e-mail contact information of business; name of primary contact; and a list of any projects or contracts for which Bidder currently owes monies to said firm, which list shall include a description of the project or contract, the amount currently due to said firm, the period of time for which those monies have been owed, and the expected date of payment of those monies.
- (q) Bidder shall participate in active apprenticeship and training programs approved by and registered with the United States Department of Labor Bureau of Apprenticeship and Training for each of the trades of work contemplated under the Contract. Bidder shall be able to provide evidence of Bidder's participation in such apprenticeship and training programs.
- (r) Bidder shall only employ subcontractors who meet the requirements prescribed in this section and other sections of these specifications.
- (s) Bidder shall be able to provide such other information as may assist the Village in determining whether the Bidder is adequately prepared to fulfill the Contract.

These requirements and qualifications are not intended to discourage bidding, to make it difficult for qualified Bidders to submit Bids, or to discourage beginning contractors. The purpose of these requirements and qualifications is to allow the Village to obtain sufficient information about Bidder's financial state, available equipment, personnel, and previous work experience so that the Village may mitigate the hazards involved in awarding contracts to parties who may not be qualified to perform the Work as specified.

A copy of Village of Villa Park Ordinance No. 3733, amending the requirements of bidders for construction projects, is provided as Appendix A

BID PRICE LIMITATIONS

The bid price for TRAFFIC CONTROL AND PROTECTION shall not exceed 5 percent of the total bid price. If the bid price for TRAFFIC CONTROL AND PROTECTION exceeds 5 percent of the total bid price, the Village may reject the Bid.

The bid price for CONSTRUCTION LAYOUT (SPECIAL) shall not exceed 2 percent of the total bid price. If the bid price for CONSTRUCTION LAYOUT (SPECIAL) exceeds 2 percent of the total bid price, the Village may reject the Bid.

The bid price for PRE-CONSTRUCTION VIDEO RECORDING shall not exceed 1 percent of the total bid price. If the bid price for PRE-CONSTRUCTION VIDEO RECORDING exceeds 1 percent of the total bid price, the Village may reject the Bid.

Bidder, in submitting a Bid, certifies that the Bid is in compliance with these requirements. The Village's determination as to whether or not to reject a Bid that does not comply with these requirements will be final, and Bidder, in submitting a Bid, agrees to be bound by that determination.

BIDS TO REMAIN SUBJECT TO ACCEPTANCE

All bids shall remain subject to acceptance by the Village for a period of 90 calendar days from the date of the bid opening. The Village may extend the acceptance period by up to an additional 90 calendar days upon written notice to all bidders by the Village. The Village may, in its sole discretion, release any bid and return the bid bond prior to the end of the acceptance period.

INCREASED OR DECREASED QUANTITIES

The Village reserves the right to increase or decrease the amount of work shown in the plans in accordance with Section 109 of the Standard Specifications.

FINAL INSPECTION

Final inspection shall be in accordance with Article 105.13 of the Standard Specifications, except as modified herein. Revise the second paragraph of Article 105.13 of the Standard Specifications to read:

“If the inspection discloses any work, in whole or in part, as being unsatisfactory, the Engineer will give the Contractor the necessary instructions for correction of same, and the Contractor shall comply with such instructions within 14 calendar days of receipt of such instructions. The Contractor shall give the Engineer not less than 48 hours' notice, in writing, prior to beginning any such corrective work. Upon completion of all corrective work, the Contractor shall give the Engineer notice in writing. Upon receipt of such notice, the Engineer will make another inspection which shall constitute the final inspection provided the work has been satisfactorily completed. In such event, the Engineer will notify the Contractor in writing of the date of final inspection.”

DATE OF MANUFACTURE

Revise the second paragraph of Article 106.01 of the Standard Specifications to read:

“All materials to be permanently incorporated in the work, including, but not limited to, frames, grates, lids, castings, fire hydrants, pipe, drainage and utility structures, valves, stops, fittings, and hardware, shall have been manufactured no earlier than January 1 of the calendar year in which they are to be installed unless otherwise specifically prescribed in the contract documents.”

MATERIAL ORDERS

The Contractor shall order all materials with long lead times within 5 working days from execution of Contract to minimize any project delays and meet project completion date. **Any issues procuring material shall be brought to the attention of the Village and Engineer immediately.**

MATERIAL AND EQUIPMENT STORAGE

The project site may have limited access and boundary constraints, all of which the Contractor accepts full responsibility. Any staging area(s) for materials, equipment, or other which are required by the Contractor shall be the responsibility of the Contractor.

If necessary, the Contractor shall enter into a separate contract with a private property owner **WHICH IS OUTSIDE THE SCOPE OF THIS CONTRACT.**

IRON, STEEL, COPPER, AND BRASS PRODUCTS

Revise the third paragraph of Article 106.01 of the Standard Specifications to read:

All iron, steel, copper, and brass products, which are to be incorporated into the work, shall be domestically manufactured or produced and fabricated, unless an exception is expressly permitted under Federal and/or State law and written permission is given by Owner. The Contractor shall obtain from the iron, steel, copper, or brass producer and/or fabricator, in addition to the mill analysis, a certification that all iron, steel, copper, or brass materials meet these domestic source requirements.

HOLIDAYS

Revise the list of legal holidays in Article 107.09 of the Standard Specifications to read:

New Year's Day
Easter
Memorial Day
Independence Day
Labor Day
Halloween

Thanksgiving Day
Thanksgiving Friday
Christmas Eve
Christmas Day
New Year's Eve

PUBLIC CONVENIENCE AND SAFETY (D-1)

Effective: May 1, 2012
Revised: July 15, 2012

Add the following to the end of the fourth paragraph of Article 107.09:

“If the holiday is on a Saturday or Sunday, and is legally observed on a Friday or Monday, the length of Holiday Period for Monday or Friday shall apply.”

Add the following sentence after the Holiday Period table in the fourth paragraph of Article 107.09:

“The Length of Holiday Period for Thanksgiving shall be from 5:00 AM the Wednesday prior to 11:59 PM the Sunday After”

Delete the fifth paragraph of Article 107.09 of the Standard Specifications:

“On weekends, excluding holidays, on roadways with Average Daily Traffic of 25,000 or greater, all lanes shall be open to traffic from 3:00 P.M. Friday to midnight Sunday except where structure construction or major rehabilitation makes it impractical.”

USE OF FIRE HYDRANTS

Revise Article 107.18 of the Standard Specifications to read:

“107.18 Use of Fire Hydrants. If Contractor requires water for the completion of construction operations, and desires to obtain water from the Village, the Contractor shall submit a written request to the Village. If such request is approved by the Village, the Contractor shall obtain water from the fire hydrant located at 100 West Home Avenue, adjacent to the Village of Villa Park Fleet Maintenance Garage. Contractor’s use of said hydrant and methods of obtaining water shall be in compliance with all applicable ordinances, rules, and regulations concerning such use. Contractor shall furnish all labor and equipment necessary to make a connection to said hydrant, and to obtain and transport water.

Contractor, upon each occasion water is obtained, shall make photographic documentation of such occasion.

If Contractor makes application for temporary use of a hydrant meter and the application is not approved, Contractor shall make record of the quantity of water obtained, along with the date and time obtained, and shall report such information after each use to the Village of Villa Park Public Works Department, 11 West Home Avenue. If such use takes place outside of the normal working hours of the Public Works Department, Contractor shall report such information immediately upon the commencement of normal working hours.

Contractor shall not use, operate, or obtain water from any hydrants other than the hydrant prescribed. Contractor shall not obtain water from the Village for construction operations or activities not under contract with the Village.

If a water main break occurs and the Village determines that the water main break is a result of Contractor’s use of a hydrant, the Village may require the Contractor to repair the water main break in accordance with all applicable construction standards and requirements and at no cost to the contract, or may repair the water main break by other means and invoice the Contractor for reimbursement of the Village’s costs.

Water usage will be measured as the actual quantity of water obtained from the Village by the Contractor, which quantity shall be rounded up to the nearest 1,000 gallons.

INSURANCE

Insurance and indemnification shall be in accordance with applicable sections of the Standard Specifications and shall also be in accordance with the “IRMA Contractual Insurance Guidelines”, incorporated herein as Appendix B. If a conflict is determined to exist between the requirements prescribed in the Standard Specifications and the requirements prescribed in the IRMA Contractual Insurance Guidelines, such conflict will be resolved as follows:

- a. If a particular type of insurance coverage is required by one standard but not by both, that type of insurance coverage will be required.
- b. If the minimum limits of insurance coverage required by one standard differ from those required by the other standard, the higher minimum limits of insurance coverage will prevail.
- c. If any other conflicts are determined to exist between the requirements prescribed in the two standards, the stricter of the two requirements will prevail. The Village will make the final determination as to what constitutes a stricter requirement.

Contractor shall provide a Certificate of Insurance prior to execution of Contract. Such Certificate of Insurance shall list the Village of Villa Park as Certificate Holder and shall also name the following entity or entities as additional insureds:

Village of Villa Park

Certificate of Insurance shall include a CG5036 Additional Insured Endorsement.

Should said Certificate of Insurance expire prior to final acceptance of the project, said certificate shall be automatically renewed and provided to the Village of Villa Park a minimum of 30 days prior to expiration.

SUBCONTRACTING

Add the following to the end of the first paragraph of Article 108.01 of the Standard Specifications:

“Should Contractor fail to respond to such request for proof from Engineer or should Engineer determine that Contractor’s response to such request is not sufficient to prove that a proposed subcontractor has the experience, ability, and equipment the work requires, Engineer may prohibit the employ of said subcontractor.”

Add the following paragraph to the end of Article 108.01 of the Standard Specifications:

“The apparent low Bidder shall submit to Owner within 7 calendar days after the receipt of bids, a list of the names of Bidder’s proposed subcontractors and material suppliers along with a description of the work to be performed or the materials to be supplied by each.”

PROGRESS SCHEDULE

Revise Article 108.02 of the Standard Specifications to read:

After the award of the contract and prior to starting work, the Contractor shall submit to the Engineer a satisfactory progress schedule or critical path schedule which shall show the proposed sequence of work, and how the Contractor proposes to complete the various items of work within the number of calendar days set up in the contract or on or before the completion date specified in the contract.

Work will not be permitted to start until a progress schedule has been submitted and approved. The contract time will commence to run in accordance with the contract documents regardless of whether a progress schedule has been submitted or approved. If the contract time has commenced to run and a progress schedule has not been submitted, the contract time will continue to run until the day that a progress schedule is submitted. The contract time will be

suspended upon submittal of a progress schedule and while such progress schedule is under review. The contract time will resume to run upon provision of a response by the Engineer to the submitted progress schedule, regardless of whether such response is approval or rejection.

The progress schedule shall be used as a basis for establishing the controlling item of construction operations and for checking the progress of the work. The controlling item shall be defined as the item which must be completed either partially or completely to permit continuation of progress. It shall be the responsibility of the Contractor to show the intended rate of production for each controlling item listed on the schedule during the period such item is controlling.

The Contractor shall confer with the Engineer at regular intervals in regard to the prosecution of the work according to the progress schedule or critical path schedule.

If at any time the actual progress is ten or more calendar days behind the proposed progress shown on the approved schedule, the Engineer will select the controlling item of work for the purpose of checking the progress of the work. In such cases the Contractor shall submit a satisfactory revised progress schedule or revised critical path schedule. The Engineer will continue to determine the controlling item until the Contractor has submitted a satisfactory revised progress schedule or revised critical path schedule and such schedule has been approved.

Payment under this contract may be withheld if, at any time, a satisfactory and approved progress schedule is not in place.

WORKING HOURS

Working hours will be between 7:00 A.M. and 5:00 P.M., Monday through Friday, excluding holidays as designated by the Contract.

Contractor will not permit the performance of Work outside these working hours without Owner's written consent, which may be given after prior written request to Engineer, except as otherwise required for the safety of persons or the Work or property at the Site or adjacent thereto, and except as otherwise stated in the Contract Documents. Any approval for working outside of Working Hours does not include hours or days that fall within a holiday period.

If Contractor permits the performance of Work outside these working hours, Contractor shall compensate Owner for the costs of inspection and other services provided by Owner or Engineer. Owner will determine the rates at which such inspection and other services are to be compensated. Owner will determine the interval or intervals at which billing will take place, and may, at Owner's discretion, submit invoices for payment to Contractor, or deduct the costs from any monies due or to become due to the Contractor from Owner.

CONTRACT TIME

The work shall achieve substantial completion by November 21, 2025 unless additional time is granted in accordance with the specifications.

Substantial completion shall be defined as the completion of, at a minimum, underground utility work, roadway excavation, aggregate subgrade improvements, aggregate base course placement, concrete curb and gutter installation, binder course placement, surface course placement, driveway pavement placement, sidewalk removal and replacement, grading of parkways, placement of topsoil, and such other items of work as may be identified by the Engineer.

The work shall achieve final completion in accordance with the special provision FINAL INSPECTION.

No allowance will be made for delay or suspension of the work due to the fault of the Contractor.

FAILURE TO COMPLETE THE WORK ON TIME

Replace the table in Article 108.09 of the Standard Specifications with the following:

Schedule of Day of Overrun in Contract Time		Deductions for Each	
Original Contract Amount		Daily Charges	
From Than	More To Including	and Calendar Day	Work Day
\$ 0	\$ 100,000	\$ 2,000	\$ 2,800
100,000	500,000	3,000	4,200
500,000	1,000,000	4,000	5,600
1,000,000	3,000,000	5,000	7,000
3,000,000	6,000,000	6,000	8,400
6,000,000	12,000,000	9,000	12,600
12,000,000	And over	25,000	35,000

Add the following paragraph to the end of Article 108.09 of the Standard Specifications:

“Liquidated damages will be charged for each day of overrun in both substantial completion deadlines and final completion deadlines.”

MONIES DUE TO OWNER

Should Contractor be subject to fines, deductions, reimbursements, liquidated damages, or other monies due to Owner, the cost thereof may be deducted from any monies due or to become due the Contractor under this contract or any other contract between the Owner and the Contractor. Bidders and Contractor, in submitting Bids, acknowledge this requirement and agree to be bound by it.

PARTIAL PAYMENTS

Add the following after the first paragraph of Article 109.07(a) of the Standard Specifications:

“Owner will deduct from the amount so determined for the completed work a sum of ten percent to be retained until the final payment. Owner may, at its discretion, reduce the percentage of such retention prior to the final payment, but in no event shall the amount retained be reduced to less than ten percent prior to substantial completion, nor shall such retention be reduced to less than two percent or less than \$5,000.00 prior to the final payment.

TREE CARE

Tree care work shall be defined as all tree pruning, tree root pruning, tree planting, tree assessment, and tree remediation. All tree care work shall be in accordance with Section 201 of the Standard Specifications, except as modified herein.

All tree care work shall be performed by an ISA Certified Arborist or shall be performed under the direct supervision of an ISA Certified Arborist. The certified arborist shall submit a copy of their current and valid certificate to the Owner prior to any tree care work taking place. The certified arborist whose certificate is provided shall be on site at all times when tree care work is taking place. All such tree care work shall either be performed by the certified arborist or shall be performed under the direct supervision of the certified arborist.

TREE DAMAGE

If any trees are damaged during the project, the Contractor shall obtain and file with the Village a tree assessment of the damaged trees. The tree assessment shall detail the health and condition of the damaged trees and shall provide a recommendation for or against retention of each affected tree. The tree assessment will not be paid for.

When, in the opinion of the Village, a tree assessment obtained by the Contractor does not represent an independent evaluation, the Village may direct the Contractor to obtain a second tree assessment of the damaged trees and may provide the Contractor with a list of not less than two ISA Certified Arborists, from which list the Contractor shall select one for completion of the second tree assessment. The second tree assessment, if so directed, will not be paid for.

When multiple tree assessments are obtained, it will be the opinion of the Village as to which tree assessment is utilized for the purposes of addressing the remaining requirements of this section. Further references to the tree assessment in this section shall refer to the tree assessment selected by the Village.

If the tree assessment results in a recommendation for retention of an affected tree, the Contractor shall perform tree remediation of the affected tree as follows.

Trees subject to tree remediation will be fertilized and treated with Paclobutrazol. Treatment shall consist of air spading 2 holes for every 3 sq. ft. of area within the dripline of the tree to a depth of 12 in. to 18 in. and backfilling with Biochar.

If a tree subject to tree remediation is an Oak or an Elm species and the damage occurred between the dates of April 15 and October 15, then in addition to the Paclobutrazol treatment specified herein, the damage to the tree will be sealed in a manner approved by the Engineer.

The Owner may require the Contractor to perform additional methods of tree remediation or methods of tree remediation different from those listed if recommended by the tree assessment or deemed appropriate by the Owner.

Tree remediation will not be paid for.

If the tree assessment results in a recommendation against retention of an affected tree, the Contractor shall remove the affected tree. Should removal of the affected tree result in any additional damage to the site or result in the need for any additional restoration, Contractor shall repair or replace the damage or perform the restoration as deemed necessary by the Engineer. This work shall be in accordance with Article 201.04 of the Standard Specifications, except that the work will not be paid for.

If a tree is to be removed due to damage, a deduction will be applied to monies due or that might become due the Contractor. This Tree Damage Deduction will be applied as follows.

Trees to be removed due to damage will be measured per unit of diameter where one unit is equal to 1 in. The diameter will be measured at a point 4.5 ft. above the highest ground level at the base of the tree and will be determined by dividing the measured circumference of the tree by 3.1416.

If the tree had tree protection installed at the time of damage and if, in the opinion of the Village, the tree protection was correctly installed at the time of damage, the Tree Damage Deduction will be \$300 per unit of diameter of the tree.

If the tree did not have tree protection installed at the time of damage or if, in the opinion of the Village, the tree protection was not correctly installed at the time of damage, the Tree Damage Deduction will be \$800 per unit of diameter of the tree.

If a tree is to be removed due to damage, then in addition to the Tree Damage Deduction, Contractor shall also furnish and plant a tree of a species and caliper selected by the Owner at a location determined by the Owner. This work shall be in accordance with Section 253 of the Standard Specifications, except that the work will not be paid for

BITUMINOUS MATERIALS

Prime coat will not be applied on aggregate bases as a part of this contract.

Tack coat shall be in accordance with the pay item special provision BITUMINOUS MATERIALS (TACK COAT).

SAW CUTS

Saw cuts are required at all pavement removal limits. All saw cuts performed during the construction process will not be paid for separately but shall be included in the cost of the removal item adjacent to the saw cut.

TEST STRIPS

Test strips shall be in accordance with Section 406 and Section 1030 of the Standard Specifications, except as modified herein.

Remove all references to the payment of test strips and the payment of the HMA mixture in test strips from the Standard Specifications.

Test strips and the HMA mixture in test strips, if required, will not be measured for payment but shall be included in the unit bid prices of hot mix asphalt binder courses and hot mix asphalt surface courses.

DUST CONTROL WATERING

Contractor shall apply water by means of spraying to control dust onsite.

Materials. Water and equipment that can apply the water by means of spraying. The methods of watering must meet the approval of the ENGINEER.

DUST CONTROL WATERING shall be considered incidental to the cost of the contract and will not be paid for separately.

CONFLICTS WITH UTILITIES

Conflicts with utilities shall be in accordance with Article 107.40 of the Standard Specifications, except as modified herein.

Add the following after the first paragraph of Article 107.40 of the Standard Specifications:

“Unless otherwise specified in the contract documents, utility facilities which are encountered during construction operations and are not in direct conflict with a proposed utility to be constructed under this contract shall be left undisturbed in place and shall be protected by the Contractor against damage and the interruption of utility services as a result of construction operations.”

PORTLAND CEMENT CONCRETE PAVEMENTS AND SIDEWALKS

Where forms are to be used for the installation of concrete, all such forms shall be wood.

Wood forms for all concrete installation shall be of a width that exceeds the required thickness of the concrete being installed

MOBILIZATION

Mobilization shall be in accordance with Section 671 of the Standard Specifications, except as modified herein.

Revise Article 671.02 of the Standard Specifications to read:

“**671.02 Basis of Payment.** This work will not be paid for separately but shall be included in the unit bid prices of the items for which this work applies.”

KEEPING ROADS OPEN TO TRAFFIC

All roads shall remain open to traffic unless otherwise shown on the contract plans. When necessary to close one lane because of construction, the Contractor shall maintain one-way traffic during construction hours with the use of signs and flaggers as shown on the Traffic Control Standards. Two lanes of traffic will be maintained during nights and weekends when no construction activities are being carried on.

ACCESS TO ADJACENT PROPERTIES

Unless otherwise specified in the contract documents or permitted by the Engineer, Contractor shall at all times maintain access to all properties, residences, and businesses located within or adjacent to the project area.

Exception will be made when concrete curb and gutter or concrete driveway pavement construction are taking place.

When access to adjacent properties is restricted due to construction, the Contractor shall maintain one-way traffic during construction hours with the use of signs and flaggers as shown on the Traffic Control Standards. Two lanes of traffic will be maintained during nights and weekends when no construction activities are being carried on.

CONSTRUCTION NOTICES

It shall be the CONTRACTOR's responsibility to distribute all construction notifications. This work will not be measured for payment but shall be included in the total contract cost. The construction notices shall be reviewed and approved by the ENGINEER prior to being distributed. Notices shall be issued at the following stages:

	<u>Activity</u>	<u>Notice Period Required</u>
1.	Prior to driveway removal.	3 consecutive days prior
2.	Prior to water and sanitary service Interruption.	2 consecutive days prior
3.	Prior to pavement/curb removal.	2 consecutive days prior
4.	Prior to paving.	2 consecutive days prior

The CONTRACTOR will also be responsible for distributing and/or redistributing notices in case of any delays due to inclement weather or for any other reason for extended stoppages (i.e. strikes) in the construction schedule.

Notices shall be considered distributed when all affected residents have received notices as well as a copy delivered and/or emailed to Public Works. The copy to Public Works shall be delivered the same day it is distributed to the residents.

Should the CONTRACTOR fail to distribute or post notices per the request of the VILLAGE, the CONTRACTOR shall not be allowed to start work on the given task until proper notification has been provided. No additional contract time will be allowed for compliance with this requirement.

PORTABLE TOILET

Contractor shall furnish a portable toilet meeting Federal, State, and local health department requirements stocked with lavatory and sanitary supplies at all times. The portable toilet shall be provided at a location approved by the Engineer. The portable toilet shall be maintained in a clean and sanitary condition and shall be emptied as needed. This work will not be paid for separately but shall be included in the cost of the contract.

PROGRESS MEETINGS

Construction progress meetings will be held on a weekly basis beginning when the contract time commences to run and continuing until the project achieves final completion. Owner may, at its discretion, reduce the frequency of such meetings or cancel any or all such meetings. Contractor's representative in responsible charge of the work shall be present at all scheduled progress meetings. If Contractor's representative is not present at one or more scheduled progress meetings, Contractor shall compensate Owner for the costs of attendance of such meetings by Owner's and

Engineer's representatives. Owner will determine the rates at which such attendance is to be compensated. Owner will determine the interval or intervals at which billing will take place, and may, at Owner's discretion, submit invoices for payment to Contractor, or deduct the costs from any monies due or to become due to the Contractor from Owner.

OPERATION OF WATER DISTRIBUTION FACILITIES

Contractor shall not operate any water distribution facilities, including, but not limited to, valves and hydrants. If Contractor requires the operation of such facilities, Contractor shall provide a minimum of 48 hours' notice to the Village and the Village will operate such facilities.

CONSTRUCTION SAFETY AND HEALTH STANDARDS

It is a condition of this contract and shall be made a condition of each subcontract entered into pursuant to this contract that the Contractor and any Subcontractor shall not require any laborer or mechanic employed in performance of that contract to work in surroundings or under working conditions which are unsanitary, hazardous, or dangerous to their health or safety, as determined under Federal Construction Safety and Health Standards.

MAINTENANCE WARRANTY

The Contractor shall execute and deliver to the Village, before final payment will be issued, a written warranty, in a form satisfactory to the Village, which guarantees that all work is in accordance with the contract and will not be defective. This warranty shall guarantee all work for a period of 1 year from the date of final inspection.

The Contractor shall furnish a warranty bond in an amount equal to 10 percent of the final contract amount, or \$55,000.00, whichever is greater, by a surety satisfactory to the Village to guarantee Contractor's warranty to repair defective work.

If, within the warranty period, the Village determines any work to be defective, a written notice of such deficiency will be sent to the Contractor by certified mail.

The Contractor shall, within 14 calendar days of receipt of the notice of deficiency, and without cost to the Village, correct or repair such defective work, or remove and replace the defective work in accordance with the contract requirements for the item or items in question.

If Contractor desires an extension of time to complete the corrective work, Contractor shall make such request in writing within 10 calendar days of receipt of the notice of deficiency. After the Contractor has filed a request for an extension of time, the Village will notify the Contractor, in writing, whether or not such extension will be approved.

Should the Contractor fail to complete the corrective work within the 14 calendar days or within such extended time as may have been allowed, the Contractor shall be liable and shall pay to the Village the amount shown in the Schedule of Deductions for Each Day of Overrun in Contract Time, not as a penalty but as liquidated damages, for each day of overrun beyond the 14 calendar days or such extended time as may have been allowed.

MAINTENANCE OF ROADWAYS (D1)

Effective: September 30, 1985
Revised: November 1, 1996

Beginning on the date that work begins on this project, the Contractor shall assume responsibility for normal maintenance of all existing roadways within the limits of the improvement. This normal maintenance shall include all repair work deemed necessary by the Engineer, but shall not include snow removal operations. Traffic control and protection for maintenance of roadways will be provided by the Contractor as required by the Engineer.

If items of work have not been provided in the contract, or otherwise specified for payment, such items, including the accompanying traffic control and protection required by the Engineer, will be paid for in accordance with Article 109.04 of the "Standard Specifications".

RESPONSIBILITY FOR VANDALISM

The Contractor shall be responsible for the protection of all equipment and materials. Any equipment or materials which are stolen, missing, lost, damaged, or vandalized shall be the Contractor's responsibility to replace or repair as needed at no additional cost to the contract.

The Contractor shall be responsible for the defacement of any concrete pours before they have set up. Concrete pavement, sidewalk, driveway, or curbing that has been defaced, in the opinion of the Engineer, shall be removed and replaced by the Contractor at Contractor's expense.

EXCAVATION AND BACKFILLING OF DRAINAGE AND UTILITY STRUCTURES

Excavation, bedding and backfilling of drainage and utility structures which are constructed, reconstructed, or adjusted as a part of this contract will not be paid for separately but shall be included in the cost of the items to which this work pertains.

SALVAGE AND DISPOSAL OF EXISTING MATERIALS

Existing manufactured materials which are removed and are not to be reused, including, but not limited to, frames, grates, lids, castings, sign posts, sign panels, fire hydrants, valves, stops, and fittings, shall remain the property of the Village unless the Engineer waives this requirement as specified herein.

Existing manufactured materials which are removed and are not to be reused will be inspected by the Engineer. Materials which are determined by the Engineer to be in satisfactory condition shall remain the property of the Village and shall be delivered by the Contractor to the Village of Villa Park Public Works Department yard located at 51 South Ardmore Avenue in Villa Park. Delivery shall be made during the normal working hours of the Village of Villa Park Public Works Department and the Contractor shall coordinate the day, time, and other details of delivery with the Village.

Materials which are determined by the Engineer to be in unsatisfactory condition shall become the property of the Contractor and shall be removed from the site by the end of the workday and properly disposed of by the Contractor. The delivery or disposal of materials will not be paid for separately but shall be included in the cost of all items that include removal of existing materials.

ADJUSTING RINGS

All drainage and utility structures which are constructed, reconstructed, or adjusted as a part of this contract shall have adjusting rings installed between the topmost section of the structure and the casting.

Each structure shall be fitted with a minimum of one adjusting ring and a maximum of two adjusting rings. The topmost adjusting ring on each structure shall be rubber. The second adjusting ring on each structure, if needed, shall be precast concrete with steel reinforcement. The total height of all adjusting rings on a single structure shall be a minimum of 2 in. and a maximum of 12 in.

The mating faces of adjusting rings shall be smooth, parallel, and free of cracks, chips, spalling, or casting irregularities. Rubber mastic shall be installed between each joint.

Adjusting rings will not be paid for separately but shall be included in the cost of the items to which this work pertains.

FRAMES, GRATES, AND LIDS

Frames, grates, lids, and all other castings furnished under this contract shall be in accordance with Section 602 and Section 604 of the Standard Specifications, except as modified herein.

Castings shall conform to ASTM A48 Class 30. Castings shall be free of cracks, holes, swells, cold shuts, and patches. Castings shall not be coated or painted.

Frames, grates, lids, and other castings shall be furnished in accordance with the following:

- Type 1 frames and closed lids
- Type 1 frames and open lids
- Type 11 frames and grates located in barrier curb and gutter shall be with curb box
- Type 11 frames and grates located in depressed curb and gutter shall be with depressed curb grate

All other castings not specified above shall be as shown on the plans or as directed by the Engineer. If any of the castings specified are not compatible in the field due to frame height or other constraints, the Contractor shall propose an alternate casting to the Engineer for approval and shall furnish the alternate casting if approved.

Frames, grates, lids, and other castings located within curb ramps or crosswalks shall be substituted with ADA compliant castings.

All closed lid castings furnished under this contract shall be self-sealing, gasketed, watertight, and shall have machined bearing surfaces and concealed pick holes. The top surface of all closed lids shall be embossed with the words "VILLAGE OF VILLA PARK". The top surface of closed lids shall also be embossed with the word "SANITARY", "STORM", or "WATER" as appropriate.

Enviro-curb logos on curb boxes for Type 11 frames and grates shall have the words "DUMP NO WASTE" and "DRAINS TO RIVER" or "DRAINS TO WATERWAY" cast into the top of all curb boxes.

This work will not be paid for separately but shall be included in the cost of all pay items that include the furnishing of frames, grates, lids, or other castings.

STORM STRUCTURES

All manholes, catch basins, and inlets installed under this contract shall be in accordance with Section 602 of the Standard Specifications, except as modified herein.

Unless otherwise noted, the proposed catch basin, manholes, inlets and drainage structures shall be Precast Reinforced Concrete (per Section 1042 of the Standard Specifications).

Removal of existing storm structures, if a new manhole, catch basin or inlet is to be installed at the same location, shall be included in cost of the new structure to be installed.

Removing existing storm structures shall consist of removal and disposal of existing structures in accordance with Section 605 of the Standard Specifications. The word Structure shall be understood to mean all storm manholes, catch basins and inlets.

This work will be paid for at the contract unit price per EACH for catch basins, manholes and inlets with the appropriate frames, grates and lids.

PROTECTION OF EXISTING DRAINAGE FACILITIES DURING CONSTRUCTION

Unless otherwise noted in the contract plans, the existing drainage facilities shall remain in use during the period of construction.

Locations of existing drainage structures and sewers, if shown on the contract plans, are approximate. Prior to commencement of work, the Contractor, at his/her own expense, shall determine the exact location of existing structures which are within the proposed construction site.

All drainage structures are to be kept free from any debris resulting from construction operations. All work and materials necessary to prevent accumulation of debris in the drainage structure resulting from construction operations shall be removed at the Contractor's own expense, and no extra compensation will be allowed.

Unless reconstruction or adjustment of an existing manhole, catch basin, or inlet is called for in the contract plans or ordered by the Engineer, the proposed work shall meet the existing elevations of these structures. Should reconstruction or adjustment of a drainage structure be required by the Engineer in the field, the necessary work and payment shall be done in accordance with Section 602 and Article 104.02 respectively, of the Standard Specifications.

Existing frames and grates are to remain unless otherwise noted in the contract plans or as directed by the Engineer. Frames and grates that are missing or damaged prior to construction shall be replaced. The type of replacements frame or grate shall be determined by the Engineer, and replacement and payment for same shall be in accordance with Section 604 and Article 104.02 respectively, of the Standard Specifications unless otherwise noted in the plans or special provisions.

DROP HAMMERS

The use of drop hammers or similar equipment will not be permitted.

AVAILABLE REPORTS

No project specific reports were prepared.

When applicable, the following checked reports and record information is available for Bidders' reference upon request:

- Record structural plans
- Preliminary Site Investigation (PSI)
- Preliminary Environmental Site Assessment (PESA)
- Soils/Geotechnical Report
- Boring Logs
- Pavement Cores
- Location Drainage Study (LDS)
- Hydraulic Report
- Noise Analysis
- Other: N/A

Those seeking these reports should request access from:

Kevin L. Mantels, P.E.– Assistant Village Engineer
Village of Villa Park
Engineering Division
Phone: (630) 834-8505
Email: kmantels@invillapark.com

ADJUSTMENTS AND RECONSTRUCTIONS (D1)

Effective: March 15, 2011

Revised: October 1, 2021

Revise the first paragraph of Article 602.04 to read:

“602.04 Concrete. Cast-in-place concrete for structures shall be constructed of Class SI concrete according to the applicable portions of Section 503. Cast-in-place concrete for pavement patching around adjustments and reconstructions shall be constructed of Class PP-2 concrete, unless otherwise noted in the plans, according to the applicable portions of Section 1020.”

Revise the third, fourth and fifth sentences of the second paragraph of Article 602.11(c) to read:

“Castings shall be set to the finished pavement elevation so that no subsequent adjustment will be necessary, and the space around the casting shall be filled with Class PP-2 concrete, unless otherwise noted in the plans, to the elevation of the surface of the base course or binder course. HMA surface or binder course material shall not be allowed. The pavement may be opened to traffic according to Article 701.17(e)(3)b.”

Revise Article 603.05 to read:

“603.05 Replacement of Existing Flexible Pavement. After the castings have been adjusted, the surrounding space shall be filled with Class PP-2 concrete, unless otherwise noted in the plans, to the elevation of the surface of the base course or binder course. HMA surface or binder course material shall not be allowed. The pavement may be opened to traffic according to Article 701.17(e)(3)b.”

Revise Article 603.06 to read:

“603.06 Replacement of Existing Rigid Pavement. After the castings have been adjusted, the pavement and HMA that was removed, shall be replaced with Class PP-2 concrete, unless otherwise noted in the plans, not less than 9 in. (225 mm) thick. The pavement may be opened to traffic according to Article 701.17(e)(3)b.

The surface of the Class PP concrete shall be constructed flush with the adjacent surface.”

Revise the first sentence of Article 603.07 to read:

“603.07 Protection Under Traffic. After the casting has been adjusted and the Class PP concrete has been placed, the work shall be protected by a barricade and two lights according to Article 701.17(e)(3)b.”

DRAINAGE AND INLET PROTECTION UNDER TRAFFIC (D1)

Effective: April 1, 2011

Revised: April 2, 2011

Add the following to Article 603.02 of the Standard Specifications:

- “(i) Temporary Hot-Mix Asphalt (HMA) Ramp (Note 1) 1030
- “(j) Temporary Rubber Ramps (Note 2)

Note 1. The HMA shall have maximum aggregate size of 3/8 in. (95 mm).

Note 2. The rubber material shall be according to the following.

Property	Test Method	Requirement
Durometer Hardness, Shore A	ASTM D 2240	75 ±15
Tensile Strength, psi (kPa)	ASTM D 412	300 (2000) min
Elongation, percent	ASTM D 412	90 min
Specific Gravity	ASTM D 792	1.0 - 1.3
Brittleness, °F (°C)	ASTM D 746	-40 (-40)°

Revise Article 603.07 of the Standard Specifications to read:

603.07 Protection Under Traffic. After the casting has been adjusted and the Class PP concrete has been placed, the work shall be protected by a barricade and two lights according to Article 701.17(e)(3)b.

When castings are under traffic before the final surfacing operation has been started, properly sized temporary ramps shall be placed around the drainage and/or utility castings according to the following methods.

- (a) Temporary Asphalt Ramps. Temporary hot-mix asphalt ramps shall be placed around the casting, flush with its surface and decreasing to a featheredge in a distance of 2 ft (600 mm) around the entire surface of the casting.
- (b) Temporary Rubber Ramps. Temporary rubber ramps shall only be used on roadways with permanent posted speeds of 40 mph or less and when the height of the casting to be protected meets the proper sizing requirements for the rubber ramps as shown below.

Dimension	Requirement
Inside Opening	Outside dimensions of casting + 1 in. (25 mm)
Thickness at inside edge	Height of casting ± 1/4 in. (6 mm)
Thickness at outside edge	1/4 in. (6 mm) max.
Width, measured from inside opening to outside edge	8 1/2 in. (215 mm) min

Placement shall be according to the manufacturer's specifications.

Temporary ramps for castings shall remain in place until surfacing operations are undertaken within the immediate area of the structure. Prior to placing the surface course, the temporary ramp shall be removed. Excess material shall be disposed of according to Article 202.03."

friction aggregate (D1)

Effective: January 1, 2011

Revised: December 1, 2021

Revise Article 1004.03(a) of the Standard Specifications to read:

“1004.03 Coarse Aggregate for Hot-Mix Asphalt (HMA). The aggregate shall be according to Article 1004.01 and the following.

(a) Description. The coarse aggregate for HMA shall be according to the following table.

Use	Mixture	Aggregates Allowed
Class A	Seal or Cover	<u>Allowed Alone or in Combination</u> ^{5/} : Gravel Crushed Gravel Carbonate Crushed Stone Crystalline Crushed Stone Crushed Sandstone Crushed Slag (ACBF) Crushed Steel Slag Crushed Concrete
HMA Low ESAL	Stabilized Subbase or Shoulders	<u>Allowed Alone or in Combination</u> ^{5/} : Gravel Crushed Gravel Carbonate Crushed Stone Crystalline Crushed Stone Crushed Sandstone Crushed Slag (ACBF) Crushed Steel Slag ^{1/} Crushed Concrete
HMA High ESAL Low ESAL	Binder IL-19.0 or IL-19.0L SMA Binder	<u>Allowed Alone or in Combination</u> ^{5/ 6/} : Crushed Gravel Carbonate Crushed Stone ^{2/} Crystalline Crushed Stone Crushed Sandstone Crushed Slag (ACBF) Crushed Concrete ^{3/}

Use	Mixture	Aggregates Allowed	
HMA High ESAL Low ESAL	C Surface and Binder IL-9.5 IL-9.5FG or IL-9.5L	<u>Allowed Alone or in Combination</u> ^{5/} : Crushed Gravel Carbonate Crushed Stone ^{2/} Crystalline Crushed Stone Crushed Sandstone Crushed Slag (ACBF) Crushed Steel Slag ^{4/} Crushed Concrete ^{3/}	
HMA High ESAL	D Surface and Binder IL-9.5 or IL-9.5FG	<u>Allowed Alone or in Combination</u> ^{5/} : Crushed Gravel Carbonate Crushed Stone (other than Limestone) ^{2/} Crystalline Crushed Stone Crushed Sandstone Crushed Slag (ACBF) Crushed Steel Slag ^{4/}	
		<u>Other Combinations Allowed:</u>	
		<i>Up to...</i>	<i>With...</i>
		25% Limestone	Dolomite
		50% Limestone	Any Mixture D aggregate other than Dolomite
75% Limestone	Crushed Slag (ACBF) or Crushed Sandstone		
HMA High ESAL	E Surface IL-9.5 SMA Ndesign 80 Surface	<u>Allowed Alone or in Combination</u> ^{5/ 6/} : Crushed Gravel Crystalline Crushed Stone Crushed Sandstone Crushed Slag (ACBF) Crushed Steel Slag No Limestone.	
		<u>Other Combinations Allowed:</u>	
		<i>Up to...</i>	<i>With...</i>
		50% Dolomite ^{2/}	Any Mixture E aggregate
		75% Dolomite ^{2/}	Crushed Sandstone, Crushed Slag (ACBF), Crushed Steel Slag, or Crystalline Crushed Stone

Use	Mixture	Aggregates Allowed	
		75% Crushed Gravel ^{2/}	Crushed Sandstone, Crystalline Crushed Stone, Crushed Slag (ACBF), or Crushed Steel Slag
HMA High ESAL	F Surface IL-9.5 SMA Ndesign 80 Surface	<u>Allowed Alone or in Combination</u> ^{5/6/} :	
		Crystalline Crushed Stone Crushed Sandstone Crushed Slag (ACBF) Crushed Steel Slag No Limestone.	
		<u>Other Combinations Allowed:</u>	
		<i>Up to...</i>	<i>With...</i>
		50% Crushed Gravel ^{2/} or Dolomite ^{2/}	Crushed Sandstone, Crushed Slag (ACBF), Crushed Steel Slag, or Crystalline Crushed Stone

- 1/ Crushed steel slag allowed in shoulder surface only.
- 2/ Carbonate crushed stone (limestone) and/or crushed gravel shall not be used in SMA Ndesign 80.
- 3/ Crushed concrete will not be permitted in SMA mixes.
- 4/ Crushed steel slag shall not be used as binder.
- 5/ When combinations of aggregates are used, the blend percent measurements shall be by volume.”
- 6/ Combining different types of aggregate will not be permitted in SMA Ndesign 80.”

HOT-MIX ASPHALT BINDER AND SURFACE COURSE (D1)

Effective: November 1, 2019
 Revised: January 1, 2025

Revise Article 1004.03(c) to read:

“(c) Gradation. The coarse aggregate gradations shall be as listed in the following table.

Use	Size/Application	Gradation No.
Class A-1, A-2, & A-3	3/8 in. (10 mm) Seal	CA 16 or CA 20
Class A-1	1/2 in. (13 mm) Seal	CA 15
Class A-2 & A-3	Cover Coat	CA 14
HMA High ESAL	IL-19.0; Stabilized Subbase IL-19.0	CA 11 ^{1/}
	SMA 12.5 ^{2/}	CA 13 ^{4/} , CA 14, or CA 16

	SMA 9.5 ^{2/}	CA 13 ^{3/4/} or CA 16 ^{3/}
	IL-9.5	CA 16, CM 13 ^{4/}
	IL-9.5FG	CA 16
HMA Low ESAL	IL-19.0L	CA 11 ^{1/}
	IL-9.5L	CA 16

- 1/ CA 16 or CA 13 may be blended with the CA 11.
- 2/ The coarse aggregates used shall be capable of being combined with the fine aggregates and mineral filler to meet the approved mix design and the mix requirements noted herein.
- 3/ The specified coarse aggregate gradations may be blended.
- 4/ CA 13 shall be 100 percent passing the 1/2 in. (12.5mm) sieve.”

Revise Article 1004.03(e) of the Standard Specifications to read:

“(e) Absorption. For SMA the coarse aggregate shall also have water absorption ≤ 2.0 percent.”

Revise the “High ESAL” portion of the table in Article 1030.01 to read:

“High ESAL	Binder Courses	IL-19.0, IL-9.5, IL-9.5FG, IL-4.75, SMA 12.5, Stabilized Subbase IL-19.0
	Surface Courses	IL-9.5, IL-9.5FG, SMA 12.5, SMA 9.5”

Revise Note 2. and add Note 6 to Article 1030.02 of the Standard Specifications to read:

“Item	Article/Section	
(g)	Performance Graded Asphalt Binder (Note 6)	1032
(h)	Fibers (Note 2)	

Note 2. A stabilizing additive such as cellulose or mineral fiber shall be added to the SMA mixture according to Illinois Modified AASHTO M 325. The stabilizing additive shall meet the Fiber Quality Requirements listed in Illinois Modified AASHTO M 325. Prior to approval and use of fibers, the Contractor shall submit a notarized certification by the producer of these materials stating they meet these requirements. Reclaimed Asphalt Shingles (RAS) may be used in Stone Matrix Asphalt (SMA) mixtures designed with an SBA polymer modifier as a fiber additive if the mix design with RAS included meets AASHTO T305 requirements. The RAS shall be from a certified source that produces either Type I or Type 2. Material shall meet requirements noted herein and the actual dosage rate will be determined by the Engineer.

Note 6. The asphalt binder shall be an SBS PG 76-28 when the SMA is used on a full-depth asphalt pavement and SBS PG 76-22 when used as an overlay, except where modified herein. The asphalt binder shall be a SBS PG 76-22 for IL-4.75, except where modified herein..”

Revise table in Article 1030.05(a) of the Standard Specifications to read:

"MIXTURE COMPOSITION (% PASSING) ^{1/}												
Sieve Size	IL-19.0 mm		SMA 12.5		SMA 9.5		IL-9.5mm		IL-9.5FG		IL-4.75 mm	
	min	max	min	max	min	max	min	max	min	max	min	max
1 1/2 in. (37.5 mm)												
1 in. (25 mm)		100										
3/4 in. (19 mm)	90	100		100								
1/2 in. (12.5 mm)	75	89	80	100		100		100		100		100
3/8 in. (9.5 mm)				65	90	100	90	100	90	100		100
#4 (4.75 mm)	40	60	20	30	36	50	34	69	60	75 ^{6/}	90	100
#8 (2.36 mm)	20	42	16	24 ^{4/}	16	32 ^{4/}	34 ^{5/}	52 ^{2/}	45	60 ^{6/}	70	90
#16 (1.18 mm)	15	30					10	32	25	40	50	65
#30 (600 μm)			12	16	12	18			15	30		
#50 (300 μm)	6	15					4	15	8	15	15	30
#100 (150 μm)	4	9					3	10	6	10	10	18
#200 (75 μm)	3.0	6.0	7.0	9.0 ^{3/}	7.5	9.5 ^{3/}	4.0	6.0	4.0	6.5	7.0	9.0 ^{3/}
#635 (20 μm)			≤ 3.0		≤ 3.0							
Ratio Dust/Asphalt Binder		1.0		1.5		1.5		1.0		1.0		1.0

- 1/ Based on percent of total aggregate weight.
- 2/ The mixture composition shall not exceed 44 percent passing the #8 (2.36 mm) sieve for surface courses with Ndesign = 90.
- 3/ Additional minus No. 200 (0.075 mm) material required by the mix design shall be mineral filler, unless otherwise approved by the Engineer.
- 4/ When establishing the Adjusted Job Mix Formula (AJMF) the percent passing the #8 (2.36 mm) sieve shall not be adjusted above the percentage stated on the table.
- 5/ When establishing the Adjusted Job Mix Formula (AJMF) the percent passing the #8 (2.36 mm) sieve shall not be adjusted below 34 percent.

6/ When the mixture is used as a binder, the maximum shall be increased by 0.5 percent passing.”

Revise Article 1030.05(b) of the Standard Specifications to read:

(b) Volumetric Requirements. The target value for the air voids of the HMA shall be 4.0 percent, for IL-4.75 and SMA mixtures it shall be 3.5 percent and for Stabilized Subbase it shall be 3.0 percent at the design number of gyrations. The voids in the mineral aggregate (VMA) and voids filled with asphalt binder (VFA) of the HMA design shall be based on the nominal maximum size of the aggregate in the mix and shall conform to the following requirements.

Mix Design	Voids in the Mineral Aggregate (VMA), % Minimum for Ndesign				
	30	50	70	80	90
IL-19.0		13.5	13.5		13.5
IL-9.5		15.0	15.0		
IL-9.5FG		15.0	15.0		
IL-4.75 ^{1/}		18.5			
SMA-12.5 ^{1/2/5/}				17.0 ^{3/} /16.0 ^{4/}	
SMA-9.5 ^{1/2/5/}				17.0 ^{3/} /16.0 ^{4/}	
IL-19.0L	13.5				
IL-9.5L	15.0				

- 1/ Maximum draindown shall be 0.3 percent according to Illinois Modified AASHTO T 305.
- 2/ The draindown shall be determined at the JMF asphalt binder content at the mixing temperature plus 30°F.
- 3/ Applies when specific gravity of coarse aggregate is ≥ 2.760 .
- 4/ Applies when specific gravity of coarse aggregate is < 2.760 .
- 5/ For surface course, the coarse aggregate can be crushed steel slag, crystalline crushed stone or crushed sandstone. For binder course, coarse aggregate shall be crushed stone (dolomite), crushed gravel, crystalline crushed stone, or crushed sandstone”

Revise the last paragraph of Article 1102.01 (a) (5) of the Standard Specifications to read:

“IL-4.75 and Stone Matrix Asphalt (SMA) mixtures which contain aggregate having absorptions greater than or equal to 2.0 percent, or which contain steel slag sand, shall have minimum surge bin storage plus haul time of 1.5 hours.”

Revise the first and second paragraphs of Articles 1030.06(c)(2) of the Standard Specifications to read:

“(2) Personnel. The Contractor shall provide a QC Manager who shall have overall responsibility and authority for quality control. This individual shall maintain active certification as a Hot-Mix Asphalt Level II technician.

In addition to the QC Manager, the Contractor shall provide sufficient personnel to perform the required visual inspections, sampling, testing, and documentation in a timely manner. Mix designs shall be developed by personnel with an active certification as a Hot-Mix Asphalt Level III technician. Technicians performing mix design testing and plant sampling/testing shall maintain active certification as a Hot-Mix Asphalt Level I technician. The Contractor may provide a technician trainee who has successfully completed the Department’s “Hot-Mix Asphalt Trainee Course” to assist in the activities completed by a Hot-Mix Asphalt Level I technician for a period of one year after the course completion date. The Contractor may also provide a Gradation Technician who has successfully completed the Department’s “Gradation Technician Course” to run gradation tests only under the supervision of a Hot-Mix Asphalt Level II Technician. The Contractor shall provide a Hot-Mix Asphalt Density Tester who has successfully completed the Department’s “Nuclear Density Testing” course to run all nuclear density tests on the job site.”

Add Article 1030.06(d)(3) to the Standard Specifications to read:

“(3) The Contractor shall take possession of any Department unused backup or dispute resolution HMA mixture samples or density specimens upon notification by the Engineer. The Contractor shall collect the HMA mixture samples or density specimens from the location designated by the Engineer. The HMA mixture samples or density specimens may be added to RAP stockpiles according to Section 1031.”

Revise the second paragraph of Articles 1030.07(a)(11) and 1030.08(a)(9) of the Standard Specifications to read:

“When establishing the target density, the HMA maximum theoretical specific gravity (Gmm) will be based on the running average of four available Department test results for that project. If less than four Gmm test results are available, an average of all available Department test results for that project will be used. The initial Gmm will be the last available Department test result from a QMP project. If there is no available Department test result from a QMP project, the Department mix design verification test result will be used as the initial Gmm.”

Revise the following table and notes in Article 1030.09 (c) of the Standard Specifications to read:

CONTROL LIMITS							
Parameter	IL-19.0, IL-9.5, IL-9.5FG, IL-19.0L, IL- 9.5L		SMA-12.5, SMA-9.5		IL-4.75		
	Individual Test	Moving Avg. of 4	Individual Test	Moving Avg. of 4	Individual Test	Moving Avg. of 4	
% Passing: 1/							
1/2 in. (12.5 mm)	± 6 %	± 4 %	± 6 %	± 4 %			
3/8 in. (9.5mm)			± 4 %	± 3 %			
# 4 (4.75 mm)	± 5 %	± 4 %	± 5 %	± 4 %			
# 8 (2.36 mm)	± 5 %	± 3 %	± 4 %	± 2 %			
# 16 (1.18 mm)			± 4 %	± 2 %	± 4 %	± 3 %	

# 30 (600 μm)	± 4 %	± 2.5 %	± 4 %	± 2.5 %		
Total Dust Content # 200 (75 μm)	± 1.5 %	± 1.0 %			± 1.5 %	± 1.0 %
Asphalt Binder Content	± 0.3 %	± 0.2 %	± 0.2 %	± 0.1 %	± 0.3 %	± 0.2 %
Air Voids ^{2/}	± 1.2 %	± 1.0 %	± 1.2 %	± 1.0 %	± 1.2 %	± 1.0 %
Field VMA ^{3/}	-0.7 %	-0.5 %	-0.7 %	-0.5 %	-0.7 %	-0.5 %

- 1/ Based on washed ignition oven or solvent extraction gradation.
- 2/ The air voids target shall be a value equal to or between 3.2 % and 4.8 %.
- 3/ Allowable limit below minimum design VMA requirement.

Revise Article 1030.09(g)(2) of the Standard Specifications to read:

“(2) The Contractor shall complete split verification sample tests listed in the Limits of Precision table in Article 1030.09(h)(1).”

In the Supplemental Specifications, replace the revision for the end of the third paragraph of Article 1030.09(h)(2) with the following:

“When establishing the target density, the HMA maximum theoretical specific gravity (Gmm) will be the Department mix design verification test result.”

Add after third sentence of Article 1030.09(b) to read:

“ If the Contractor and Engineer agree the nuclear density test method is not appropriate for the mixture, cores shall be taken at random locations determined according to the QC/QA document "Determination of Random Density Test Site Locations". Core densities shall be determined using the Illinois Modified AASHTO T 166 or T 275 procedure.”

Revise Table 1 and Note 4/ of Table 1 in Article 406.07(a) of the Standard Specifications to read:

	Breakdown/Intermediate Roller (one of the following)	Final or more of Roller of (one or more of the following)	Density Requirement
IL-9.5, IL-9.5FG, IL-19.0 ^{1/}	V _D , P, T _B , 3W, O _T , O _B	V _S , T _B , T _F , O _T	As specified in Section 1030
IL-4.75 and SMA ^{3/ 4/}	T _B , 3W, O _T	T _F , 3W	As specified in Section 1030
Mixtures on Bridge Decks ^{2/}	T _B	T _F	As specified in Articles 582.05 and 582.06.

“4/ The Contractor shall provide a minimum of two steel-wheeled tandem rollers (T_B), and/or three-wheel (3W) rollers for breakdown, except one of the (T_B) or (3W) rollers shall be 84 inches (2.14 m) wide and a weight of 315 pound per linear inch (PLI) (5.63 kg/mm) and one of the (T_B) or (3W) rollers can be substituted for an oscillatory roller (O_T). T_F rollers shall be a minimum of 280 lb/in. (50 N/mm). The 3W and T_B rollers shall be operated at a uniform

speed not to exceed 3 mph (5 km/h), with the drive roll for T_B rollers nearest the paver and maintain an effective rolling distance of not more than 150 ft (45 m) behind the paver.”

Add the following after the fourth paragraph of Article 406.13 (b):

“The plan quantities of SMA mixtures shall be adjusted using the actual approved binder and surface Mix Design’s G_{mb} .”

Revise first paragraph of Article 1030.10 of the Standard Specifications to read:

“A test strip of 300 ton (275 metric tons), except for SMA mixtures it will be 400 ton (363 metric ton), will be required for each mixture on each contract at the beginning of HMA production for each construction year according to the Manual of Test Procedures for Materials “Hot Mix Asphalt Test Strip Procedures”. At the request of the Producer, the Engineer may waive the test strip if previous construction during the current construction year has demonstrated the constructability of the mix using Department test results.”

Revise fourth paragraph of Article 1030.10 of the Standard Specifications to read:

“When a test strip is constructed, the Contractor shall collect and split the mixture according to the document “Hot-Mix Asphalt Test Strip Procedures”. The Engineer, or a representative, shall deliver split sample to the District Laboratory for verification testing. The Contractor shall complete mixture tests stated in Article 1030.09(a). Mixture sampled shall include enough material for the Department to conduct mixture tests detailed in Article 1030.09(a) and in the document “Hot-Mix Asphalt Mixture Design Verification Procedure” Section 3.3. The mixture test results shall meet the requirements of Articles 1030.05(b) and 1030.05(d), except Hamburg wheel tests will only be conducted on High ESAL mixtures during production.”

HOT-MIX ASPHALT – MIXTURE DESIGN VERIFICATION AND PRODUCTION (D1)

Effective: January 1, 2019
 Revised: December 1, 2021

Add to Article 1030.05 (d)(3) of the Standard Specifications to read:

“ During mixture design, prepared samples shall be submitted to the District laboratory by the Contractor for verification testing. The required testing, and number and size of prepared samples submitted, shall be according to the following tables.

High ESAL – Required Samples for Verification Testing	
Mixture	Hamburg Wheel and I-FIT Testing ^{1/2/}
Binder	total of 3 - 160 mm tall bricks
Surface	total of 4 - 160 mm tall bricks

Low ESAL – Required Samples for Verification Testing	
Mixture	I-FIT Testing ^{1/2/}
Binder	1 - 160 mm tall brick
Surface	2 - 160 mm tall bricks

- 1/ The compacted gyratory bricks for Hamburg wheel and I-FIT testing shall be 7.5 ± 0.5 percent air voids.
- 2/ If the Contractor does not possess the equipment to prepare the 160 mm tall brick(s), twice as many 115 mm tall compacted gyratory bricks will be acceptable.

Revise the fourth paragraph of Article 1030.10 of the Standard Specifications to read:

“When a test strip is not required, each HMA mixture shall still be sampled on the first day of production: I-FIT and Hamburg wheel testing for High ESAL; I-FIT testing for Low ESAL. Within two working days after sampling the mixture, the Contractor shall deliver gyratory cylinders to the District laboratory for Department verification testing. The High ESAL mixture test results shall meet the requirements of Articles 1030.05(d)(3) and 1030.05(d)(4). The Low ESAL mixture test results shall meet the requirements of Article 1030.05(d)(4). The required number and size of prepared samples submitted for the Hamburg wheel and I-FIT testing shall be according to the “High ESAL - Required Samples for Verification Testing” table in Article 1030.05(d)(3) above.”

Add the following to the end of Article 1030.10 of the Standard Specifications to read:

“Mixture sampled during first day of production shall include approximately 60 lb (27 kg) of additional material for the Department to conduct Hamburg wheel testing and approximately 80 lb (36 kg) of additional material for the Department to conduct I-FIT testing. Within two working days after sampling, the Contractor shall deliver prepared samples to the District laboratory for verification testing. The required number and size of prepared samples submitted for the Hamburg wheel and I-FIT testing shall be according to the “High ESAL - Required Samples for Verification Testing” table in Article 1030.05(d)(3) above.”

STATUS OF UTILITIES (D-1)

Effective: June 1, 2016

Revised: April 1, 2025

Utility companies and/or municipal owners located within the construction limits of this project have provided the following information regarding their facilities and the proposed improvements. The tables below contain a description of specific conflicts to be resolved and/or facilities which will require some action on the part of the Department's contractor to proceed with work. Each table entry includes an identification of the action necessary and, if applicable, the estimated duration required for the resolution.

UTILITIES TO BE ADJUSTED

NO KNOWN UTILITIES TO BE ADJUSTED

Conflicts noted below have been identified by following the suggested staging plan included in the contract. The company has been notified of all conflicts and will be required to obtain the necessary permits to complete their work; in some instances, resolution will be a function of the construction staging. The responsible agency must relocate, or complete new installations as noted below; this work has been deemed necessary to be complete for the Department's contractor to then work in the stage under which the item has been listed.

Pre-Stage

STAGE / LOCATION	TYPE	DESCRIPTION	RESPONSIBLE AGENCY	DURATION OF TIME
No Conflicts Anticipated				

All Stages: 0 Days Total Installation

The following contact information is what was used during the preparation of the plans as provided by the Agency/Company responsible for resolution of the conflict.

Agency/Company Responsible to Resolve Conflict	Name of contact	Phone	E-mail address
None			

UTILITIES TO BE WATCHED AND PROTECTED

NO KNOWN UTILITIES TO BE WATCHED AND PROTECTED

The areas of concern noted below have been identified by following the suggested staging plan included for the contract. The information provided is not a comprehensive list of all remaining utilities, but those which during coordination were identified as ones which might require the Department's contractor to take into consideration when making the determination of the means and methods that would be required to construct the proposed improvement.

In some instances, the contractor will be responsible to notify the owner in advance of the work to take place so necessary staffing on the owner's part can be secured.

Stage 1

STAGE / LOCATION	TYPE	DESCRIPTION	OWNER

The following contact information is what was used during the preparation of the plans as provided by the owner of the facility.

Agency/Company to Resolve Conflict	Name of contact	Phone	E-mail address

The above represents the best information available to the Department and is included for the convenience of the bidder. The days required for conflict resolution should be considered in the bid as this information has also been factored into the timeline identified for the project when setting the completion date. The applicable portions of the Standard Specifications for Road and Bridge Construction shall apply.

Estimated duration of time provided above for the first conflicts identified will begin on the date of the executed contract regardless of the status of the utility relocations. The responsible agencies will be working toward resolving subsequent conflicts in conjunction with contractor activities in the number of days noted.

The estimated relocation duration must be part of the progress schedule submitted by the contractor. A utility kickoff meeting will be scheduled between the Department, the Department's contractor and the utility companies when necessary. The Department's contractor is responsible for contacting J.U.L.I.E. prior to all excavation work.

TRAFFIC CONTROL PLAN (D1)

Traffic Control shall be according to the applicable sections of the Standard Specifications, the Supplemental Specifications, the "Illinois Manual of Uniform Traffic Control Devices for Streets and Highways", any special details and Highway Standards contained in the plans, and the Special Provisions contained herein.

Special attention is called to Articles 107.09 of the Standard Specifications and the following Highway Standards, Details, Quality Standard for Work Zone Traffic Control Devices, Special Provisions, and Recurring Special Provisions contained herein, relating to traffic control.

The Contractor shall contact the engineer and Village of Villa Park at least 72 hours in advance of beginning work.

STANDARDS

- | | | | | |
|-----------|-----------|-----------|-----------|-----------|
| 701006-05 | 701301-04 | 701311-03 | 701501-06 | 701801-06 |
| 701901-10 | | | | |

DETAILS

Traffic Control and Protection for Side Roads, Intersections, and Driveways (TC-10)

SPECIAL PROVISIONS

Work Zone Traffic Control Surveillance (LRS 3)
Flaggers in Work Zones (LRS 4)
Maintenance of Roadways
Public Convenience and Safety
Temporary Information Signing
Traffic Control and Protection (Special)
Vehicle and Equipment Warning Lights (BDE)
Work Zone Traffic Control Devices (BDE)

NOT FOR BID

PAY ITEM SPECIAL PROVISIONS

PAY ITEM #3 – SODDING, SALT TOLERANT

This work shall consist of preparing the ground surface, to be sodded and furnishing and placing the sod at all areas disturbed by the construction. All work shall be in accordance with the applicable portions of Section 252 of the Standard Specifications. **The maximum pay width shall be eighteen inches (18”) unless specifically directed otherwise by the Engineer.**

Within two (2) hours after the sod has been placed, five (5) gallons of water per square yard shall be applied. Thereafter, on days designated by the Engineer, additional water shall be placed at the rate of three (3) gallons per square yard. The number of additional applications shall not exceed fifteen (15) during the period of establishment, defined as the period of time between sod placement and when the sod becomes knitted to the soil and growing in place. The Contractor shall provide subsequent resodding until a satisfactory growth of grass is produced or if settlement occurs. Nitrogen Fertilizer Nutrient, Potassium Fertilizer Nutrient and agricultural ground limestone shall be placed according to applicable portions of Sections 250 and 252 of the IDOT Standard Specifications for Road and Bridge Construction and shall be included in this pay item.

This work shall be measured in place and the area calculated in square yards and shall be paid for at the contract unit price per SQUARE YARD for SODDING, SALT TOLERANT, which price shall be full compensation for all labor, equipment, and material to complete the work including sod, fertilizer, agricultural ground limestone and watering as specified in these special provisions.

PAY ITEM #4 – INLET FILTERS

Description. This work shall consist of installing, maintaining, and cleaning inlet filters as shown on the plans or as directed by the Engineer. This work shall be in accordance with Section 280 of the Standard Specifications, except as modified herein.

Inlet filters shall consist of metal frames with attached fabric bags. Contractor shall furnish inlet filters of appropriate sizes and shapes necessary to accommodate all different types of drainage structures encountered. The use of filter fabric without a frame will not be an acceptable material for inlet filters and will be rejected.

Contractor shall inspect and clean all inlet filters weekly, after every rainfall, and additionally as needed. Maintenance and cleaning of inlet filters will not be paid for separately but shall be included in the cost of this work.

Method of Measurement. This work will be measured for payment as each individual inlet filter installed and the unit of measurement will be each. No measurement will be made of maintenance and cleaning efforts. If an inlet filter is installed on multiple structures the inlet filter will only be measured for payment once.

Basis of Payment. This work will be paid for at the contract unit price per each for INLET FILTERS.

PAY ITEM #6 – BITUMINOUS MATERIALS (TACK COAT)

Description. This work shall consist of the preparation and application of bituminous tack coat on concrete or HMA bases prior to HMA placement. This work shall be in accordance with Section 406 of the Standard Specifications, except as modified herein.

Bituminous tack coat shall be placed at least one hour in advance of the placement of HMA, but no more than 48 hours in advance of the placement of HMA. If Contractor places tack coat more than 48 hours in advance of the placement of HMA, the tack coat will not be measured for payment, and Contractor will place tack coat again in accordance with this provision. Tack coat shall not be placed on weekends or on holidays unless permitted by the Engineer. Tack coat shall not be placed before weekends or holidays when placement of HMA is not expected to take place until after the weekend or holiday, unless permitted by the Engineer.

Basis of Payment. This work will be paid for at the contract unit price per pound of residual asphalt for BITUMINOUS MATERIALS (TACK COAT).

PAY ITEM #14 – DETECTABLE WARNINGS

Description. This work shall consist of installing detectable warnings. This work shall be in accordance with Section 424 of the Standard Specifications, except as modified herein.

Detectable warnings shall be installed at curb ramps and other locations where pedestrians are required to cross a hazardous vehicular way. Detectable warnings shall also be installed at alleys and commercial entrances where permanent traffic control devices are present.

Materials. Detectable warnings shall be pre-cast tiles. Installation shall be cast-in-place. Surface mounted applications will not be permitted. Detectable warnings shall be red in color. Detectable warning tiles shall be either rectangular or radial in shape as shown on the plans or as directed by the Engineer. The product or products to be used for detectable warnings shall be approved by the Engineer prior to use.

Construction. Installation shall be according to the manufacturer's specifications and as directed by the Engineer.

Where a curb ramp is 5 ft. in width or less and a rectangular detectable warning tile is to be used, the installation shall consist of a single detectable warning tile. If a pre-cast detectable warning tile is not manufactured in the width of the curb ramp, a larger detectable warning tile shall be furnished and shall be cut to the width of the curb ramp.

Installation of multiple detectable warning tiles at a single curb ramp will only be permitted where a curb ramp exceeds 5 ft. in width or where radial detectable warning tiles are to be used. Where multiple detectable warning tiles are permitted at a single curb ramp, they shall be mechanically joined prior to installation.

Method of Measurement. Detectable warnings will be measured for payment in place and the area computed in square feet.

Basis of Payment. This work will be paid for at the contract unit price per square foot for DETECTABLE WARNINGS.

PAY ITEM #16 – DRIVEWAY PAVEMENT REMOVAL

Description. This work shall consist of the complete removal and disposal of existing driveway pavement, including all necessary excavation, as directed by the Engineer. This work shall be completed in accordance with Section 202 and Section 440 of the Standard Specifications, except as modified herein.

Driveway pavement removal shall include the removal and disposal of existing driveway pavement, any existing base course, and existing subgrade as necessary to achieve the required depth for the installation of new aggregate base

course and new driveway pavement. All excavation of material below the existing driveway pavement required to achieve such depth will be included in this item.

Method of Measurement. This work will be measured for payment in place and the area computer in square yards.

Basis of Payment. This work will be paid for at the contract unit price per square yard for DRIVEWAY PAVEMENT REMOVAL.

PAY ITEM #17 – COMBINATION CURB AND GUTTER REMOVAL

Description. This work shall consist of the removal and disposal of existing curb and gutter, including all necessary excavation, as shown on the plans or as directed by the Engineer. This work shall be in accordance with Sections 202 and 440 of the Standard Specifications, except as modified herein.

Excavation will not be paid for separately but shall be included in the cost of this item. The Contractor shall excavate all material necessary to build the proposed curb and gutter subbase in accordance with Section 202 of the Standard Specifications. Excavated material will not be permitted to be stockpiled behind the curb.

Portions of the project limits have existing monolithic curb adjacent to concrete pavement. When monolithic curb is to be removed the curb removal shall be measured and paid for pre foot as COMBINATION CURB AND GUTTER REMOVAL. All saw cutting required to removal of monolithic curb shall be included in this item, regardless of the adjacent concrete pavement is to remain or be removed/replaced. If monolithic curb is to be removed adjacent to concrete pavement that is to remain in place, the Contractor shall saw cut a clean line approximately 1' from the face of the curb to facilitate the construction of new curb and gutter. All saw cutting shall be included in the cost of this item.

Method of Measurement and Basis of Payment. This work shall be measured and paid for at the contract unit price per lineal foot of COMBINATION CURB AND GUTTER REMOVAL.

PAY ITEM #18 – SIDEWALK REMOVAL

Description. This work shall consist of the removal and disposal of existing sidewalk as directed by the Engineer. This work shall be completed in accordance with Section 202 and Section 440 of the Standard Specifications, except as modified herein.

Sidewalk removal shall include the removal and disposal of existing sidewalk, any existing base course, and existing subgrade as necessary to achieve the required depth for the installation of new aggregate base course and new sidewalk, as well as any additional excavation which may be needed for the slope of the new sidewalk to be compliant with ADA requirements. All excavation of material below the existing sidewalk required to achieve such depth will be included in this item.

Method of Measurement. This work will be measured for payment in place and the area computed in square feet.

Basis of Payment. This work will be paid for at the contract unit price per square foot for SIDEWALK REMOVAL.

PAY ITEM #19 – CLASS D PATCHES, 6 INCH

Description. This work shall consist of the removal of the existing pavement, the necessary excavation, and the replacement with hot-mix asphalt (HMA) patches at designated locations. This work shall be in accordance with Section 442 of the Standard Specifications, except as modified herein.

Remove all references to a specified type or types of patches in the Standard Specifications.

All patches shall be saw cut full-depth prior to removal of the existing pavement. Saw cuts shall be completed no more than three days prior to removal of the existing pavement. Saw cuts will not be paid for separately, but shall be included in the cost of this work.

Where patches are to be resurfaced with a subsequent lift of hot-mix asphalt, the patches shall be constructed with Hot-Mix Asphalt Binder Course, IL-19.0, N50. The minimum thickness of each lift shall be 2.25 in. The maximum thickness of each lift shall be 4 in.

Basis of Payment. This work will be paid for at the contract unit price per square yard for CLASS D PATCHES, 6 INCH.

PAY ITEM #20 – INLET

Description. This work shall consist of constructing inlets at locations shown on the plans in accordance with Section 602 of the Standard Specifications, the details on the plan and as specified herein.

Materials. The materials shall meet the requirements of Article 602.02 of the Standard Specifications.

Construction. Structures shall be constructed in accordance with the Construction Details and Section 602 of the Standard Specifications.

The Contractor is responsible for tying in all existing storm sewers to the proposed structure. Up to 5 feet of new sewer (if required) for each existing sewer tying into the proposed structure shall be considered included in the cost of this item. Connections to existing storm sewers should be made using non-shear mission couplings. The Contractor shall be responsible for verifying the size, inverts and locations of the existing sewers to be connected to the proposed structure. Any existing storm sewers that are damaged during construction shall be replaced in kind by the Contractor at no cost to the Village. The pipe, couplings, and trench back fill shall be included in the cost of the structure and will not be paid for separately.

When a proposed inlet is to be installed at the location of an existing drainage structure, the removal of the existing structure shall be included in this item.

Removing existing drainage structures shall consist of the removal and disposal of existing catch basins and inlets in accordance with Section 604 of the Standard Specifications.

Frames, grates and lids or other castings will be paid for separately.

Method of Measurement. This work will be measured for payment as each individual structure complete installed.

Basis of Payment. This work will be paid for at the contract unit price per each for INLET, type specified.

PAY ITEM #24 – FRAMES AND GRATES, TYPE 11

Description. This work shall meet the requirements prescribed in General Special Provisions section, FRAMES, GRATES AND LIDS, shall be according to Section 602 and 604 of the Standard Specifications, the details in the plans and the following:

This item includes the replacement of frames and grates on existing structures to be adjusted or reconstructed at locations shown on the plans or as directed by the Engineer.

Type 11 frames and grates located in barrier curb and gutter shall be with curb box.

Type 11 frames and grates located in depressed curb and gutter shall be with depressed curb grate.

Frames and grates located within curb ramps or crosswalks shall be substituted with ADA compliant castings.

Enviro-curb logos on curb boxes for Type 11 frames and grates shall have the words “DUMP NO WASTE” and “DRAINS TO RIVER” or “DRAINS TO WATERWAY” cast into the top of all curb boxes.

Basis of Payment. This work will be paid for at the contract unit price per each for FRAMES AND GRATES, TYPE 11 as specified.

PAY ITEM #25 & #26 – FRAMES AND LIDS, TYPE 1

Description. This work shall meet the requirements prescribed in General Special Provisions section, FRAMES, GRATES AND LIDS, shall be according to Section 602 and 604 of the Standard Specifications, the details in the plans and the following:

This item includes the replacement of frames and lids on existing structures to be adjusted or reconstructed at locations shown on the plans or as directed by the Engineer.

Type 1 frames and closed lids self-sealing.

Type 1 frames and open lids.

Frames and lids located within curb ramps or crosswalks shall be substituted with ADA compliant castings.

All closed lid castings shall be self-sealing, gasketed, watertight, and shall have machined bearing surfaces and concealed pick holes. The top surface of all closed lids shall be embossed with the words “VILLAGE OF VILLA PARK”.

The top surface of closed lids shall also be embossed with the word “SANITARY”, “STORM”, or “WATER” as appropriate.

Basis of Payment. This work will be paid for at the contract unit price per each for FRAMES AND LIDS, TYPE 1 as specified.

PAY ITEM #28 – COMBINATION CONCRETE CURB AND GUTTER, TYPE B-6.12 (SPECIAL)

Description. This work shall consist of constructing combination concrete curb and gutter as shown on the plans or as directed by the Engineer. This work shall be in accordance with Section 606 of the Standard Specifications, except as modified herein.

Excavation will not be paid for separately but shall be included in the cost of this item.

Combination concrete curb and gutter shall be constructed on a prepared base of mechanically compacted crushed aggregate of CA-6 gradation having a minimum compacted thickness of 4 in.

Wood forms shall be used. Forms constructed of steel or Masonite will not be permitted. Forms for radius sections of the combination concrete curb and gutter shall be constructed of 1 in. thick wood boards.

The height of the curb head may vary as shown on the plans or as directed by the Engineer. Variations in the height of the curb head will not be paid for separately but shall be included in the cost of this item.

Where combination concrete curb and gutter is constructed across driveways, alleys, sidewalk curb ramps, or other designated areas, the top of the curb shall be depressed according to the details shown on the plans or as directed by the Engineer. The transition from full height curb to depressed curb shall be made over a distance equal to at least four times the difference in height between the full height curb and the depressed curb.

Where combination concrete curb and gutter is constructed across sidewalk curb ramps, the depressed curb shall be in compliance with all applicable requirements of the Americans with Disabilities Act (ADA) and the Proposed Guidelines for Accessible Rights-of-Way (PROWAG).

Where combination concrete curb and gutter is to be constructed adjacent to existing pavement that is not being reconstructed, the void between the existing pavement and the proposed combination concrete curb and gutter shall be filled in with a concrete wedge with a minimum width of 6 in. and a minimum thickness of 8 in. The concrete wedge shall be placed after the combination concrete curb and gutter has been placed and the forms have been removed. The placement of the concrete wedge will not be paid for separately but shall be included in the cost of this item.

Where combination concrete curb and gutter is to be constructed adjacent to proposed sidewalk to be constructed, the combination concrete curb and gutter shall be constructed first and shall be constructed with an integral poured ledge. The ledge shall extend horizontally a minimum of 3 in. from the back of the curb head of the combination concrete curb and gutter. The ledge shall be positioned so that the vertical distance from the top of the ledge to the top of the curb head is equal to the thickness of the proposed sidewalk. The ledge shall extend vertically to the bottom edge of the combination concrete curb and gutter. The construction of the integral poured ledge will not be paid for separately but shall be included in the cost of this item.

Expansion joints shall be constructed at 60 ft. maximum centers. Expansion joints shall also be constructed at all construction joints, all points of curvature, all points of tangency, within 5 ft. on either side of all curb structure castings, and at additional locations as directed by the Engineer. Expansion joints shall consist of a 1 in. thick preformed bituminous expansion joint filler that extends the full cross section of the combination concrete curb and gutter. Expansion joint filler material that is larger than the cross section of the combination concrete curb and gutter shall be cut to the exact cross section of the combination concrete curb and gutter. Expansion joints shall have two 18 in. long, No. 6 non-deformed epoxy-coated steel dowel bars placed at mid-depth. The dowel bars shall have a greased plastic expansion cap placed on one end of each dowel bar a minimum of 1 in. from the end of the dowel bar.

Where proposed combination concrete curb and gutter is to be constructed abutting existing combination concrete curb and gutter, the dowel bars shall be drilled into the existing combination concrete curb and gutter. This work will not be paid for separately but shall be included in the cost of this item.

Contraction joints shall be constructed at 15 ft. maximum centers. Where the location of a contraction joint coincides with the location of an expansion joint, the contraction joint may be omitted at the discretion of the Engineer. Contraction joints shall be tooled and sawed. Sawing of contraction joints shall commence as soon as the concrete has hardened sufficiently to permit sawing without excessive raveling, but in no case shall sawing commence less than 4 hours or more than 24 hours after the concrete is placed. Sawing of contraction joints shall be to a depth equal to 1/3 the thickness of the gutter flag and to a width of not less than 1/8 in. Contraction joints shall be sealed according to Article 420.12, except that joints shall be sealed with polysulfide or polyurethane joint sealant.

If Contractor fails to construct joints in accordance with the requirements of this provision and the curb cracks, the Contractor shall remove and replace the affected section of combination concrete curb and gutter extending the full length between the two adjacent joints on either side of the crack. This work will not be paid for but shall be at the Contractor's expense.

Upon removal of the forms from the back of the combination concrete curb and gutter, excavated areas behind the combination concrete curb and gutter shall be immediately backfilled. Areas where pavement or sidewalks are to be constructed shall be backfilled with crushed aggregate of CA-6 or CA-7 gradation and mechanically compacted. Areas where topsoil and sodding are to be placed shall be backfilled with non-organic material acceptable to the Engineer. This work will not be paid for separately but will be included in the cost of this item.

Basis of Payment. This work will be paid for at the contract unit price per foot for COMBINATION CONCRETE CURB AND GUTTER, TYPE B-6.12 (SPECIAL).

PAY ITEM #29 – CONSTRUCTION LAYOUT SPECIAL FOR RESURFACING WITH ADA AND STAND ALONE ADA (D1)

Effective: January 1, 2017
Revised: April 17, 2017

Description. This work shall consist of furnishing and placing construction layout stakes for the construction of ADA Ramps shown in the plans. The Contractor shall furnish and place stakes marking the locations and elevations of points indicated in the plans for ADA Ramp Construction.

The Contractor shall locate all reference points as shown on the plans and listed herein. Any additional control points required will be identified in the field by the Contractor and all field notes will be kept in the office of the Resident Engineer.

The Contractor shall provide field forces, equipment, and material to set all additional stakes for this project, which are needed to establish offset stakes, reference points, and any other horizontal and vertical controls necessary to secure a correct layout for the work.

Layout stakes shall be set to assure conformance to the ADA Ramp design shown on the plans and shall meet the approval of the Engineer.

The Contractor shall be responsible for having the finished work conform to the lines, grades, elevations, and dimensions called for in the plans. Any inspection or checking of the Contractor's layout by the Engineer and the acceptance of all or any part of it shall not relieve the Contractor of his/her responsibility to secure the proper dimensions, grades, and elevations of the work. The Contractor shall exercise care in the preservation of stakes and bench marks and shall have them reset when any are damaged, lost, displaced, removed or otherwise obliterated.

Responsibility of the Department.

The Department will make random checks of the Contractor's staking to determine if the work is in conformance with the plans. When the Contractor's work will tie into work that is being or will be done by others, checks will be made to determine if the work is in conformance with the proposed overall grade and horizontal alignment.

Where the Contractor, in setting construction stakes, discovers discrepancies, the Department will check to determine their nature and make whatever revisions are necessary to the plans. Any additional restaking required by the Engineer will be the responsibility of the Contractor. The additional restaking done by the Contractor will be paid for according to Article 109.04 of the Standard Specifications.

The Department will be responsible for the accuracy of the initial reference points shown in the plans.

It is not the responsibility of the Department, except as provided herein, to check the correctness of the Contractor's stakes. Any apparent errors will be immediately called to the Contractor's attention, and the Contractor will be required to make the necessary correction before the stakes are used for construction purposes. The Contractor shall provide the Engineer a copy of any field notes and layout diagrams produced during the course of the project.

Responsibility of the Contractor.

The Contractor shall establish from the given survey points and contract plan information, all the control points or reference points necessary to layout the ADA Ramp elements. The Contractor shall furnish and place the layout stakes. The Contractor shall notify the Engineer when the stakes are complete and available for review and approval by the Engineer at least 3 working days in advance of the actual construction.

Field notes shall be kept in standard survey field notebooks and those books shall become the property of the Department at the completion of the project. All notes shall be neat, orderly, and in accepted form.

Method of Measurement and Basis of Payment. This work will be paid for at the contract lump sum price for CONSTRUCTION LAYOUT (SPECIAL).

PAY ITEM #31 – HOT-MIX ASPHALT DRIVEWAY PAVEMENT, 4”

This work shall consist of furnishing, placing and compacting hot-mix asphalt driveway pavement at locations shown on the plans and as directed by the Engineer.

This work shall conform to the applicable Sections of Articles 355 and 406 of the IDOT Standard Specifications.

Driveways shall be constructed to a nominal thickness of 4 inches which shall consist of a minimum 2” thick surface course (HMA Surface Course, Mix “D”, IL-9.5, N50) with the balance constructed using hot mix asphalt base course (HMA Base Course, 2”). Aggregate and bituminous material prime coats shall be applied according to Article 406 and as directed by the Engineer.

Driveway pavement shall be placed in two lifts.

Method of Measurement: Hot-mix asphalt driveway pavement will be measured in place and the area computed in square yards. The pavement materials and bituminous material prime coats will not be measured for payment separately but shall be considered included in payment for Hot-Mix Asphalt Driveway Pavement.

Basis of Payment: The work will be paid at the contract unit price per square yard for HOT-MIX ASPHALT DRIVEWAY PAVEMENT, 4", which price shall be full payment for all materials, labor, and equipment necessary to construct the driveways.

PAY ITEM #32 - PROPOSED STORM SEWER CONNECTION TO EXISTING MANHOLE

Description. This item shall consist of the construction of proposed storm sewer connection to existing storm sewers or existing drainage structures at locations shown on the plans and as directed by the Engineer. This work shall consist of making a new storm sewer connection to the existing manhole as directed in Sections 502 and 550 of the Standard Specifications. The new opening in the existing drainage structure or storm sewer shall be made in a manner to minimize any structural damage to the drainage structure or storm sewer. Any damage to the existing drainage structure or storm sewer shall be repaired to the Engineer's satisfaction by the Contractor at no additional cost.

Materials. Materials shall be in accordance with Section 1024 of the Standard Specifications.

Construction Requirements: The Contractor shall carefully core into the existing structure at the line and grades as shown on the Contract Drawings. After the storm sewer is installed, the manhole shall be mortared with a non-shrink concrete grout.

Basis of Payment. The work shall be paid for at the contract unit price each for PROPOSED STORM SEWER CONNECTION TO EXISTING MANHOLE.

PAY ITEM #33 – FRAMES AND LIDS TO BE ADJUSTED (SPECIAL)

Description. This work shall conform to the requirements of Section 603 of the Standard Specifications and District Detail BD-08 "Details for Frames and Lids Adjustment with Milling" for adjustment of structures in resurfacing sections of the project.

This work shall include replacement of existing broken adjustment rings and patching inside the structures with hydraulic cement at locations as directed by the engineer. If the structure is a combination sewer or sanitary manhole then chimney seals or similar materials acceptable to Villa Park shall be provided.

Basis of Payment. This work shall be paid for at the contract unit price per each for "FRAMES AND LIDS TO BE ADJUSTED (SPECIAL)" which payment will be full compensation for constructing this item as detailed.

When a new Type 1 Frame, Closed Lid is called for on the plans it will be paid for as "FRAMES AND LIDS, TYPE 1, CLOSED LID" and it shall have the same text "STORM", "SANITARY", "WATER" as the existing frame and lid being removed.

PAY ITEM #34 – TRAFFIC CONTROL AND PROTECTION (SPECIAL)

Description. This work shall consist of the furnishing, installation, maintenance, relocation, and removal of work zone traffic control and protection. This work shall be in accordance with Section 701 of the Standard Specifications, the Supplemental Specifications, the “Illinois Manual of Uniform Traffic Control Devices”, the Highway Standards and details contained in the Plans and Special Provisions, and the Special Provisions contained herein, except as modified herein.

The bid price for TRAFFIC CONTROL AND PROTECTION (SPECIAL) shall not exceed 5 percent of the total bid price. If the bid price for TRAFFIC CONTROL AND PROTECTION (SPECIAL) exceeds 5 percent of the total bid price, the Village may reject the Bid.

Contractor shall contact the Village at least 72 hours in advance of beginning work. Construction operations shall be conducted in a manner such that streets shall be open to emergency traffic and accessible as required to local traffic. Advanced notice shall be provided to residents, police, fire, school districts, school bus companies, and trash haulers when access to any street will be temporarily closed or limited. Removal and replacement of curb and gutter and driveways shall be planned so as to cause a minimum of inconvenience to the abutting property owners. The work shall be accomplished such that the streets shall be left open to local traffic at the end of each workday.

Method of Measurement. This work will be measured for payment on a lump sum basis. No measurement will be made of any of the individual components of this work.

Basis of Payment. Traffic control and protection will be paid for at the contract lump sum price for TRAFFIC CONTROL AND PROTECTION (SPECIAL), which price shall include all of the above listed requirements, details, standards, and special provisions.

PAY ITEM #35 – TEMPORARY INFORMATION SIGNING

Effective: November 13, 1996
Revised: January 29, 2020

Description. This work shall consist of furnishing, installing, maintaining, relocating for various states of construction and eventually removing temporary informational signs. Included in this item may be ground mount signs, skid mount signs, truss mount signs, bridge mount signs, and overlay sign panels which cover portions of existing signs.

Materials. Materials shall be according to the following Articles of Section 1000 - Materials:

	<u>Item</u>	<u>Article/Section</u>
a.)	Sign Base (Note 1)	1090
b.)	Sign Face (Note 2)	1091
c.)	Sign Legends	1091
d.)	Sign Supports	1093
e.)	Overlay Panels (Note 3)	1090.02

Note 1. The Contractor may use 5/8 inch (16 mm) instead of 3/4 inch (19 mm) thick plywood.

Note 2. The sign face material shall be in accordance with the Department's Fabrication of Highway Signs Policy.

Note 3. The overlay panels shall be 0.08 inch (2 mm) thick.

GENERAL CONSTRUCTION REQUIREMENTS

Installation. The sign sizes and legend sizes shall be verified by the Contractor prior to fabrication.

Signs which are placed along the roadway and/or within the construction zone shall be installed according to the requirements of Article 701.14 and Article 720.04. The signs shall be 7 ft (2.1 m) above the near edge of the pavement and shall be a minimum of 2 ft (600 mm) beyond the edge of the paved shoulder. A minimum of two (2) posts shall be used.

The attachment of temporary signs to existing bridges, sign structures or sign panels shall be approved by the Engineer. Any damage to the existing signs and/or structures due to the Contractor's operations shall be repaired or signs replaced, as determined by the Engineer, at the Contractor's expense.

Method of Measurement. This work shall be measured for payment in square feet (square meters) edge to edge (horizontally and vertically).

All hardware, posts or skids, supports, bases for ground mounted signs, connections, which are required for mounting these signs will be included as part of this pay item.

Basis of Payment. This work shall be paid for at the contract unit price per square foot (square meter) for TEMPORARY INFORMATION SIGNING.

PAY ITEM #36 – DRAINAGE STRUCTURES TO BE ADJUSTED

Description. This item of work shall consist of the adjustment of the drainage structures in the curb and gutter line in accordance with the applicable portions of Section 602 of the Standard Specifications. The work shall include replacement of existing broken adjustment rings and patching inside the structures between pipes and structures with hydraulic cement at locations as directed by the Engineer.

Basis of Payment. This work shall be paid for at the contract unit price each for DRAINAGE STRUCTURES TO BE ADJUSTED which price shall be payment in full for furnishing all materials, labor and equipment necessary to adjust the drainage structures complete in place.

PAY ITEM #37 - STORM SEWERS WATER MAIN QUALITY PIPE

Description. This work shall consist of constructing storm sewer of the diameter specified adjacent to or crossing water main, at the locations shown on the plans; including but not be limited to all labor, materials, and equipment needed to perform the work as specified herein.

Construction Requirements. Storm sewers shall be constructed with water main quality pipe and joints that comply with 35 Ill. Adm. Code 653.119 and shall be pressure tested in accordance with "AWWA Standard for Installation of Ductile-Iron Water Mains and their Appurtenances" for a working pressure equal to or greater than the maximum possible surcharge head to assure water tightness before backfilling.

Method of Measurement. This work will be measured for payment, in place, in units of feet.

Basis of Payment. This work will be paid for at the contract unit price per FOOT for STORM SEWERS, TYPE SPECIFIED, WATER MAIN QUALITY PIPE, installed.

PAY ITEM #38 – PRE-CONSTRUCTION VIDEO RECORDING

Description. This work shall consist of performing color video and audio recording of the project area and other areas which may be impacted by construction.

Pre-construction video recordings will include coverage of the project area and all other areas which may be impacted by construction. Video recordings will also include construction easements when applicable. Video recordings will provide a visual record of all physical features within those areas, including, but not limited to, roadways, pavements, curbs, gutters, driveways, driveway aprons, sidewalks, carriage walks, parkways, trees, landscaping, shrubbery, plantings, landscaping walls, retaining walls, signs, sign posts, fences, utility poles, light poles, utilities, equipment, manholes, b-boxes, cleanouts, valves, curb structures, pipelines, buildings, mailboxes, and any other features located within the project area.

Video recordings will begin with an audio narrative which provides the current date and time, the name of the Village and name of project, and a description of both the starting location and the location or locations to be recorded, including street name or names, street addresses, and any additional information which may be necessary to describe the location and subject of viewing.

Video recordings will maintain viewer orientation by means of an audio commentary in the audio track of each video recording which provides an explanation of what is being viewed; and by videotaping landmarks and readily identifiable objects, including property addresses, street signs, or other appropriate objects, at appropriate intervals.

Pre-construction video recordings will be recorded at a rate of travel not exceeding 50 feet per minute, and zooming and panning rates will be controlled to provide clarity of features during playback. The finished product will be provided with bright, clear pictures and accurate colors free from distortion, tearing, rolls, or other forms of picture imperfection. The audio will have proper volume and clarity. All recordings will be performed at times of satisfactory visibility, and when no more than 10 percent of ground is obscured by snow, leaves, or other cover.

If any element within or portion of the project area is not adequately documented by the pre-construction video recording so as to definitively demonstrate its condition prior to the start of construction, Contractor will assume responsibility for the repair, restoration or replacement of that element or portion of the project area. Such repair, restoration or replacement will be to equal or better condition than previously existing, and will further comply with all standards and provisions which govern the work in question.

Schedule. Preconstruction video recording will be performed according to the following schedule:

- (a) Pre-construction video recording will be completed after a Notice to Proceed has been issued.
- (b) Pre-construction video recording will be completed after the Joint Utility Locating Information for Excavators (JULIE) request for the project area has cleared.
- (c) Pre-construction video recording will be completed before any equipment, materials, or other items are delivered to the site
- (d) Pre-construction video recording will be completed no more than 7 chargeable days prior to the start of construction.
- (e) Pre-construction video recording will be completed, the required pre-construction video recording deliverables will be submitted to the Engineer, and the Engineer will review and issue written approval of the pre-construction video recording before any activity other than utility locating will be permitted to start. Such activity will include, but not be limited to, delivery of materials and equipment, installation of traffic control and erosion control, and completion of construction layout

and tree protection. No days will be charged against the contract time while the video is under review by the Engineer, including the day the deliverables are submitted and the day a response is provided. If the pre-construction video recording or any portions thereof are rejected, the contract time will commence to run until revisions are submitted.

- (f) Pre-construction video recording will be submitted to Engineer for review prior to commencement of any construction, and receive acceptance of recordings prior to commencement of construction. Any areas found not acceptable to the Owner will be re-recorded at no additional cost to the contract.

Deliverables. Video will be high-definition, with a minimum resolution of 1280 × 720 pixels per frame. Video will be filmed in a landscape aspect ratio. Video filmed in a portrait aspect ratio will be considered unacceptable and will be rejected.

Preconstruction video recordings will be provided as electronic files of .avi, .mp4, .m4v, .mkv, .wmv, or .mpg file format, or of such other file format as may be approved by Engineer. Preconstruction video recordings will be provided as independent digital container format files, which container files will include all video, audio, and other electronic information necessary to view the preconstruction video recording as intended.

Video DVD will be considered an unacceptable format for providing preconstruction video recordings, and will be rejected.

Pre-construction video recording electronic files will be provided on a portable electronic media device or devices of one of the following types: USB flash drive, SD flash memory card, CF flash memory card, data DVD, external hard drive, or such other portable electronic media device as may be approved by Engineer. Preconstruction video recording electronic files may also be provided via online file sharing, cloud storage, File Transfer Protocol (FTP), or other online or network file transfer methods if approved by Engineer.

Pre-construction video recording electronic files will be accompanied by corresponding logs which document the dates, times, and locations covered by each preconstruction video recording electronic file.

Contractor shall maintain copies of all items submitted to Engineer for Contractor's own use and record.

Method of Measurement. This work will be measured for payment on a lump sum basis. No measurement will be made of the individual components of this effort.

Basis of Payment. Pre-construction video recording will be paid for at the contract lump sum price for PRE-CONSTRUCTION VIDEO RECORDING.

Ordinance No. 3733

AN ORDINANCE OF THE VILLAGE OF VILLA PARK, DUPAGE COUNTY, ILLINOIS AMENDING THE REQUIREMENTS OF BIDDERS FOR CONSTRUCTION PROJECTS

WHEREAS, the Village of Villa Park (the “*Village*”) is a duly organized and validly existing non home-rule municipality created in accordance with the Constitution of the State of Illinois of 1970 and the laws of the State; and,

WHEREAS, section 8-9-1 of the Illinois Municipal Code (65 ILCS 5/8-9-2) allows the Village to require competitive bidding after advertising for bids in the manner prescribed by ordinance; and,

WHEREAS, the President and Board of Trustees desire to adopt purchasing procedures to provide for additional requirements of bidders for construction projects to have active apprenticeship and training programs approved and registered with the United States Department of Labor’s Bureau of Apprenticeship and Training and to have bidders show three similar projects they constructed within the last five years.

NOW, THEREFORE, BE IT ORDAINED by the President and Board of Trustees of the Village of Villa Park, DuPage County, Illinois, as follows:

Section 1. That Section 2-219 of the Villa Park Municipal Code, as amended, be and is hereby amended by placing the existing text as subsection A. and adding a new subsection B. to read as follows:

“B. A responsible bidder for the construction of public works projects shall meet and submit evidence of compliance with the following requirements:

- (1) All applicable laws prerequisite to doing business in the State of Illinois,
- (2) A federal employer tax identification number or social security number,
- (3) Provision of Section 2000(e) of Chapter 21, Title 42 of the United States Code and Federal Executive Order No. 11246 as amended by Executive Order No. 11375 (known as the Equal Opportunity Employer provisions),
- (4) Certificates of insurance indicating the following coverage’s: general liability, worker’s compensation, completed operations, automobile, hazardous occupation and product liability
- (5) Compliance with all provisions of the Illinois Prevailing Wage Act, including wages, medical and hospitalization insurance and retirement for those trades covered in the Act,
- (6) The bidder and all bidder’s sub-contractors must participate in active apprenticeship and training programs approved and registered with the United States Department of Labor’s Bureau of Apprenticeship and Training for each of the trades of work contemplated under the proposed contract,
- (7) All contractors and sub-contractors are required to file certified payrolls as specified in Illinois Pubic Act 94-0515, and follow all provisions of the Employee Classification Act (820 ILCS 185/1 et seq.), and

(8) All bidders must provide three (3) projects of a similar nature constructed in the immediate past five (5) years with the name, address and telephone number of the contact person having knowledge of the project along with three (3) references (name, address, and telephone number) with knowledge of the integrity and business practices of the bidder.”

Section 2. This Ordinance shall be in full force and effect upon its passage, approval, and publication as provided by law.

Passed this 11 day of February, 2013.

AYES: ALL

NAYS: Aiello Bulthuis

ABSENT: _____

Approved this 11 day of February, 2013.

Village President

Attest:

Village Clerk



Published in pamphlet form:

2-11, 2013

IRMA

CONTRACTUAL INSURANCE GUIDELINES

I. INSURANCE REQUIREMENTS

Contractor shall procure and maintain, for the duration of the contract, insurance against claims for injuries to persons or damages to property, which may arise from or in connection with the performance of the work hereunder by the Contractor, his agents, representatives, employees or subcontractors.

MINIMUM SCOPE OF INSURANCE

Coverage shall be at least as broad as:

- A. Insurance Services Office Commercial General Liability occurrence form CG 0001 with the member named as additional insured, on a form at least as broad as the attached sample endorsement including ISO Additional Insured Endorsement CG 2010 (Exhibit A), CG 2026 (Exhibit B).

CG2037 - Completed Operations – (Exhibit C)
Required if box is checked ; and

- B. Owners and Contractors Protective Liability (OCP) policy with the member as insured

Required if box is checked ; and

- C. Insurance Service Office Business Auto Liability coverage form number CA 0001, Symbol 01 "Any Auto."

- D. Workers' Compensation as required by the Workers' Compensation Act of the State of Illinois and Employers' Liability insurance.

Coverage required for employee exposure to lead, if box is checked

- E. Builder Risk Property Coverage with member as loss payee
Required if box is checked .

- F. Environmental Impairment/Pollution Liability Coverage for pollution incidents as a result of a claim for bodily injury, property damage or remediation costs from an incident at, on or migrating beyond the contracted work site. Coverage shall be extended to Non-Owned Disposal sites resulting from a pollution incident at, on or mitigating beyond the site; and also provide coverage for incidents occurring during transportation of pollutants.

Required if box is checked .

MINIMUM LIMITS OF INSURANCE

Contractor shall maintain limits no less than the following, **if required under above scope**:

- A. Commercial General Liability: \$1,000,000 combined single limit per occurrence for bodily injury, and property damage and \$1,000,000 per occurrence for personal injury. The general aggregate shall be twice the required occurrence limit. Minimum General Aggregate shall be no less than \$2,000,000 or a project/contract specific aggregate of \$1,000,000.

- B. Owners and Contractors Protective Liability (OCP): \$1,000,000 combined single limit per occurrence for bodily injury and property damage.
- C. Business Automobile Liability: \$1,000,000 combined single limit per accident for bodily injury and property damage.
- D. Workers' Compensation and Employers' Liability: Workers' Compensation coverage with statutory limits and Employers' Liability limits of \$500,000 per accident.
- E. Builder's Risk: Shall insure against "All Risk" of physical damage, including water damage (flood and hydrostatic pressure not excluded), on a completed replacement cost basis.
- F. Environmental Impairment/Pollution Liability: \$1,000,000 combined single limit per occurrence for bodily injury, property damage and remediation costs.

DEDUCTIBLES AND SELF-INSURED RETENTIONS

Any deductibles or self-insured retentions must be declared to and approved by the member. At the option of the member, either: the insurer shall reduce or eliminate such deductibles or self-insured retentions as respects the member, its officials, employees, agents and volunteers; or the Contractor shall procure a bond guaranteeing payment of losses and related investigation, claim administration and defense expenses.

OTHER INSURANCE PROVISIONS

The policies are to contain, or be endorsed to contain, the following provisions:

A. General Liability and Automobile Liability Coverages

1. The member, its officials, agents, employees and volunteers are to be covered as additional insureds as respects: liability arising out of the Contractor's work, including activities performed by or on behalf of the Contractor; products and completed operations of the Contractor; premises owned, leased or used by the Contractor; or automobiles owned, leased, hired or borrowed by the Contractor. The coverage shall contain no special limitations on the scope of protection afforded to the member, its officials, agents, employees and volunteers.
2. The Contractor's insurance coverage shall be primary as respects the member, its officials, employees, agents and volunteers. Any insurance or self-insurance maintained by the member, its officials, agents, employees and volunteers shall be excess of Contractor's insurance and shall not contribute with it.
3. Any failure to comply with reporting provisions of the policies shall not affect coverage provided to the member, its officials, employees, agents and volunteers.
4. The Contractor's insurance shall contain a Severability of Interests/Cross Liability clause or language stating that Contractor's insurance shall apply separately to each insured against whom claim is made or suit is brought, except with respect to the limits of the insurer's liability.
5. If any commercial general liability insurance is being provided under an excess

or umbrella liability policy that does not “follow form,” then the Contractor shall be required to name the member, its officials, employees, agents and volunteers as additional insureds.

6. All general liability coverages shall be provided on an occurrence policy form. Claims-made general liability policies will not be accepted.
7. The contractor and all subcontractors hereby agree to waive any limitation as to the amount of contribution recoverable against them by member. This specifically includes any limitation imposed by any state statute, regulation, or case law including any Workers’ Compensation Act provision that applies a limitation to the amount recoverable in contribution such as Kotecki v. Cyclops Welding.

B. Workers' Compensation and Employers' Liability Coverage

The insurer shall agree to waive all rights of subrogation against the member, its officials, employees, agents and volunteers for losses arising from work performed by Contractor for the municipality.

1. NCCI Alternate Employer Endorsement (WC 000301) in place to insure that workers’ compensation coverage applies under contractor’s coverage rather than member’s if the member is borrowing, leasing or in day to day control of contractors employee.

Required if box is checked .

C. Professional Liability (Required if box is checked)

1. Professional liability insurance with limits not less than \$1,000,00 each claim with respect to negligent acts, errors and omissions in connection with professional services to be provided under the contract, with a deductible not-to-exceed \$50,000 without prior written approval.
2. If the policy is written on a claims-made form, the retroactive date must be equal to or preceding the effective date of the contract. In the event the policy is cancelled, non-renewed or switched to an occurrence form, the Contractor shall be required to purchase supplemental extending reporting period coverage for a period of not less than three (3) years.
3. Provide a certified copy of actual policy for review.
4. Recommended Required Coverage (architect, engineer, surveyor, consultant): Professional liability insurance that provides indemnification and defense for injury or damage arising out of acts, errors, or omissions in providing the following professional services, but not limited to the following:
 - a. Preparing, approving or failure to prepare or approve maps, drawings, opinions, report, surveys, change orders, designs or specifications;
 - b. Providing direction, instruction, supervision, inspection, engineering services or failing to provide them, if that is the primary cause of injury or damage.

D. All Coverages

Each insurance policy required shall have the member expressly endorsed onto the policy as a Cancellation Notice Recipient. Should any of the policies be cancelled before the expiration date thereof, notice will be delivered in accordance with the policy provisions.

ACCEPTABILITY OF INSURERS

Insurance is to be placed with insurers with a Best's rating of no less than A-, VII and licensed to do business in the State of Illinois.

VERIFICATION OF COVERAGE

Contractor shall furnish the member with certificates of insurance naming the member, its officials, employees, agents and volunteers as additional insureds (Exhibit D), and with original endorsements affecting coverage required by this clause. The certificates and endorsements for each insurance policy are to be signed by a person authorized by that insurer to bind coverage on its behalf. The certificates and endorsements are to be received and approved by the member before any work commences. The following additional insured endorsements may be utilized: ISO Additional Insured Endorsements CG 2010 (Exhibit A) or CG 2026 (Exhibit B), and CG 2037 (Exhibit C) – Completed Operations, where required. The member reserves the right to request full certified copies of the insurance policies and endorsements.

SUBCONTRACTORS

Contractor shall include all subcontractors as insureds under its policies or shall furnish separate certificates and endorsements for each subcontractor. All coverages for subcontractors shall be subject to all of the requirements stated herein.

ASSUMPTION OF LIABILITY

The contractor assumes liability for all injury to or death of any person or persons including employees of the contractor, any sub-contractor, any supplier or any other person and assumes liability for all damage to property sustained by any person or persons occasioned by or in any way arising out of any work performed pursuant to this agreement.

II. INDEMNITY/HOLD HARMLESS PROVISION

To the fullest extent permitted by law, the Contractor hereby agrees to defend, indemnify and hold harmless the member, its officials, employees and agents against all injuries, deaths, loss, damages, claims, patent claims, suits, liabilities, judgments, cost and expenses, which may in anywise accrue against the member, its officials, agents and employees, arising in whole or in part or in consequence of the performance of this work by the Contractor, its employees, or subcontractors, or which may in anywise result therefore, except that arising out of the sole legal cause of the member, its employees or agents, the Contractor shall, at its own expense, appear, defend and pay all charges of attorneys and all costs and other expenses arising therefore or incurred in connections therewith, and, if any judgment shall be rendered against the member, its officials, employees and agents, in any such action, the Contractor shall, at its own expense, satisfy and discharge the same.

Contractor expressly understands and agrees that any performance bond or insurance policies required by this contract, or otherwise provided by the Contractor, shall in no way limit the responsibility to indemnify, keep and save harmless and defend the member, its

officials, employees and agents as herein provided.

The Contractor further agrees that to the extent that money is due the Contractor by virtue of this contract as shall be considered necessary in the judgment of the member, may be retained by the member to protect itself against said loss until such claims, suits, or judgments shall have been settled or discharged and/or evidence to that effect shall have been furnished to the satisfaction of the member.

III. SAFETY/LOSS PREVENTION

Safety/Loss Prevention Program Requirements

- Successful bidder will provide written confirmation that a safety/loss prevention program was in place at least 90 days prior to submitting the bid proposal.
- Evidence of completed employee safety training can be provided.

Regulatory Requirements

- Successful bidder must comply with all applicable laws, regulations, and rules promulgated by any Federal, State, County, Municipal and/or other governmental unit or regulatory body now in effect or which may be in effect during the performance of the work. Included within the scope of the laws, regulations, and rules referred to in this paragraph but in no way to operate as a limitation, are Occupational Safety & Health Act (OSHA), Illinois Department of Labor (IDOL), Department of Transportation, all forms of traffic regulations, public utility, Intrastate and Interstate Commerce Commission regulations, Workers' Compensation Laws, Prevailing Wage Laws, the Social Security Act of the Federal Government and any of its titles, the Illinois Department of Human Rights, Human Rights Commission, or EEOC statutory provisions and rules and regulations.
- Evidence of specific regulatory compliance will be provided by bidder, if required by owner.

EXHIBIT A

POLICY NUMBER:

COMMERCIAL GENERAL LIABILITY
CG 20 10 07 04

THIS ENDORSEMENT CHANGES THE POLICY. PLEASE READ IT CAREFULLY.

ADDITIONAL INSURED – OWNERS, LESSEES OR CONTRACTORS – SCHEDULED PERSON OR ORGANIZATION

This endorsement modifies insurance provided under the following:

COMMERCIAL GENERAL LIABILITY COVERAGE PART

SCHEDULE

Name Of Additional Insured Person(s) Or Organization(s):	Location(s) Of Covered Operations

Information required to complete this Schedule, if not shown above, will be shown in the Declarations.

A. Section II – Who Is An Insured is amended to include as an additional insured the person(s) or organization(s) shown in the Schedule, but only with respect to liability for "bodily injury", "property damage" or "personal and advertising injury" caused, in whole or in part, by:

1. Your acts or omissions; or
2. The acts or omissions of those acting on your behalf;

in the performance of your ongoing operations for the additional insured(s) at the location(s) designated above.

B. With respect to the insurance afforded to these additional insureds, the following additional exclusions apply:

This insurance does not apply to "bodily injury" or "property damage" occurring after:

1. All work, including materials, parts or equipment furnished in connection with such work, on the project (other than service, maintenance or repairs) to be performed by or on behalf of the additional insured(s) at the location of the covered operations has been completed; or
2. That portion of "your work" out of which the injury or damage arises has been put to its intended use by any person or organization other than another contractor or subcontractor engaged in performing operations for a principal as a part of the same project.

**EXHIBIT
C**

POLICY NUMBER:

**COMMERCIAL GENERAL LIABILITY
CG 20 37 07 04**

THIS ENDORSEMENT CHANGES THE POLICY. PLEASE READ IT CAREFULLY.

**ADDITIONAL INSURED – OWNERS, LESSEES OR
CONTRACTORS – COMPLETED OPERATIONS**

This endorsement modifies insurance provided under the following:

COMMERCIAL GENERAL LIABILITY COVERAGE PART

SCHEDULE

Name Of Additional Insured Person(s) Or Organization(s):	Location And Description Of Completed Operations
<p>Information required to complete this Schedule, if not shown above, will be shown in the Declarations.</p>	

Section II – Who Is An Insured is amended to include as an additional insured the person(s) or organization(s) shown in the Schedule, but only with respect to liability for "bodily injury" or "property damage" caused, in whole or in part, by "your work" at the location designated and described in the schedule of this endorsement performed for that additional insured and included in the "products-completed operations hazard".



CERTIFICATE OF LIABILITY INSURANCE

DATE (MM/DD/YYYY)

THIS CERTIFICATE IS ISSUED AS A MATTER OF INFORMATION ONLY AND CONFERS NO RIGHTS UPON THE CERTIFICATE HOLDER. THIS CERTIFICATE DOES NOT AFFIRMATIVELY OR NEGATIVELY AMEND, EXTEND OR ALTER THE COVERAGE AFFORDED BY THE POLICIES BELOW. THIS CERTIFICATE OF INSURANCE DOES NOT CONSTITUTE A CONTRACT BETWEEN THE ISSUING INSURER(S), AUTHORIZED REPRESENTATIVE OR PRODUCER, AND THE CERTIFICATE HOLDER.

IMPORTANT: If the certificate holder is an ADDITIONAL INSURED, the policy(ies) must be endorsed. If SUBROGATION IS WAIVED, subject to the terms and conditions of the policy, certain policies may require an endorsement. A statement on this certificate does not confer rights to the certificate holder in lieu of such endorsement(s).

PRODUCER Name of Insurance Broker	CONTACT NAME: Producer/Ins. Broker Contact Info.	
	PHONE (A/C, No. Ext):	FAX (A/C, No):
E-MAIL ADDRESS:		
INSURER(S) AFFORDING COVERAGE		NAIC #
INSURER A:	Name of Insurance Company	Completed
INSURER B:	Name of Insurance Company	Completed
INSURER C:		
INSURER D:		
INSURER E:		
INSURER F:		

COVERAGES **CERTIFICATE NUMBER:** **REVISION NUMBER:**

THIS IS TO CERTIFY THAT THE POLICIES OF INSURANCE LISTED BELOW HAVE BEEN ISSUED TO THE INSURED NAMED ABOVE FOR THE POLICY PERIOD INDICATED. NOTWITHSTANDING ANY REQUIREMENT, TERM OR CONDITION OF ANY CONTRACT OR OTHER DOCUMENT WITH RESPECT TO WHICH THIS CERTIFICATE MAY BE ISSUED OR MAY PERTAIN, THE INSURANCE AFFORDED BY THE POLICIES DESCRIBED HEREIN IS SUBJECT TO ALL THE TERMS, EXCLUSIONS AND CONDITIONS OF SUCH POLICIES. LIMITS SHOWN MAY HAVE BEEN REDUCED BY PAID CLAIMS.

INSR LTR	TYPE OF INSURANCE	ADDL INSR	SUBR WVD	POLICY NUMBER	POLICY EFF (MM/DD/YYYY)	POLICY EXP (MM/DD/YYYY)	LIMITS
A	GENERAL LIABILITY <input checked="" type="checkbox"/> COMMERCIAL GENERAL LIABILITY <input type="checkbox"/> CLAIMS-MADE <input type="checkbox"/> OCCUR Owners & Cont. Prot. (OCP) if requested	Y	Y	Policy Number Inserted	Policy Start Date	Policy Start Date	EACH OCCURRENCE \$ 1,000,000 DAMAGE TO RENTED PREMISES (Ea occurrence) \$ 50,000 MED EXP (Any one person) \$ 5,000 PERSONAL & ADV INJURY \$ 1,000,000 GENERAL AGGREGATE \$ 2,000,000 PRODUCTS - COM/PO/OP AGG \$ 1,000,000
	GEN'L AGGREGATE LIMIT APPLIES PER: <input checked="" type="checkbox"/> POLICY <input type="checkbox"/> PRO-JECT <input type="checkbox"/> LOC						
A	AUTOMOBILE LIABILITY <input checked="" type="checkbox"/> ANY AUTO ALL OWNED AUTOS HIRED AUTOS <input type="checkbox"/> SCHEDULED AUTOS NON-OWNED AUTOS			Policy Number Inserted	Policy Start Date	Policy Start Date	COMBINED SINGLE LIMIT (Ea accident) \$ 1,000,000 BODILY INJURY (Per person) \$ BODILY INJURY (Per accident) \$ PROPERTY DAMAGE (Per accident) \$
A	<input checked="" type="checkbox"/> UMBRELLA LIAB EXCESS LIAB DED RETENTION \$	<input checked="" type="checkbox"/> OCCUR <input type="checkbox"/> CLAIMS-MADE	Y	Y	Policy Number Inserted	Policy Start Date	EACH OCCURRENCE \$ Per Request AGGREGATE \$ Per Request
B	WORKERS COMPENSATION AND EMPLOYERS' LIABILITY ANY PROPRIETOR/PARTNER/EXECUTIVE OFFICER/MEMBER EXCLUDED? (Mandatory in NH) If yes, describe under DESCRIPTION OF OPERATIONS below	Y/N N	N/A	Y	Policy Number Inserted	Policy Start Date	<input checked="" type="checkbox"/> WC STATU-TORY LIMITS <input type="checkbox"/> OTH-ER E.L. EACH ACCIDENT \$ 500,000 E.L. DISEASE - EA EMPLOYEE \$ 500,000 E.L. DISEASE - POLICY LIMIT \$ 500,000
	Professional Liability (other specialty coverages as requested)			Policy Number Inserted	Policy Start Date	Policy start Date	\$1,000,000 per occurrence or as requested

DESCRIPTION OF OPERATIONS / LOCATIONS / VEHICLES (Attach ACORD 101, Additional Remarks Schedule, if more space is required)
List project number, location and description.
No additional endorsements limit coverage to additional insured beyond terms of actual additional insured endorsement (CG 2010 or CG 2026). Coverage to additional insured is primary. Additional Insured: Member, its officials, employees, agents and volunteers.
* Member named as cancellation notice recipient.

CERTIFICATE HOLDER Name of Member	CANCELLATION SHOULD ANY OF THE ABOVE DESCRIBED POLICIES BE CANCELLED BEFORE THE EXPIRATION DATE THEREOF, NOTICE WILL BE DELIVERED IN ACCORDANCE WITH THE POLICY PROVISIONS. *
	AUTHORIZED REPRESENTATIVE Signature of authorized insurance company representative

CEMENT, FINELY DIVIDED MINERALS, ADMIXTURES; CONCRETE, AND MORTAR (BDE)

Effective: January 1, 2025

Revise the first paragraph of Article 285.05 of the Standard Specifications to read:

“285.05 Fabric Formed Concrete Revetment Mat. The grout shall consist of a mixture of cement, fine aggregate, and water so proportioned and mixed as to provide a pumpable slurry. Fly ash or ground granulated blast furnace (GGBF) slag, and concrete admixtures may be used at the option of the Contractor. The grout shall have an air content of not less than 6.0 percent nor more than 9.0 percent of the volume of the grout. The mix shall obtain a compressive strength of 2500 psi (17,000 kPa) at 28 days according to Article 1020.09.”

Revise Article 302.02 of the Standard Specifications to read:

“302.02 Materials. Materials shall be according to the following.

Item	Article/Section
(a) Cement	1001
(b) Water	1002
(c) Hydrated Lime	1012.01
(d) By-Product, Hydrated Lime	1012.02
(e) By-Product, Non-Hydrated Lime	1012.03
(f) Lime Slurry	1012.04
(g) Fly Ash	1010
(h) Soil for Soil Modification (Note 1)	1009.01
(i) Bituminous Materials (Note 2)	1032

Note 1. This soil requirement only applies when modifying with lime (slurry or dry).

Note 2. The bituminous materials used for curing shall be emulsified asphalt RS-2, CRS-2, HFE 90, or HFE 150; rapid curing liquid asphalt RC-70; or medium curing liquid asphalt MC-70 or MC-250.”

Revise Article 312.07(c) of the Standard Specifications to read:

“(c) Cement 1001”

Add Article 312.07(i) of the Standard Specifications to read:

“(i) Ground Granulated Blast Furnace (GGBF) Slag 1010”

Revise the first paragraph of Article 312.09 of the Standard Specifications to read:

“312.09 Proportioning and Mix Design. At least 60 days prior to start of placing CAM II, the Contractor shall submit samples of materials to be used in the work for proportioning and testing. The mixture shall contain a minimum of 200 lb (120 kg) of cement per cubic yard (cubic meter). Cement may be replaced with fly ash or ground granulated blast furnace (GGBF) slag according to Article 1020.05(c)(1) or 1020.05(c)(2), respectively, however the minimum cement content in the mixture shall be 170 lbs/cu yd (101 kg/cu m). Blends of coarse and fine aggregates will be permitted, provided the volume of fine aggregate does not exceed the volume of coarse aggregate. The Engineer will determine the proportions of materials for the mixture according to the “Portland Cement Concrete Level III Technician Course” manual. However, the Contractor may substitute their own mix design. Article 1020.05(a) shall apply, and a Level III PCC Technician shall develop the mix design.”

Revise Article 352.02 of the Standard Specifications to read:

“352.02 Materials. Materials shall be according to the following.

Item	Article/Section
(a) Cement (Note 1)	1001
(b) Soil for Soil-Cement Base Course	1009.03
(c) Water	1002
(d) Bituminous Materials (Note 2)	1032

Note 1. Bulk cement may be used for the traveling mixing plant method if the equipment for handling, weighing, and spreading the cement is approved by the Engineer.

Note 2. The bituminous materials used for curing shall be emulsified asphalt RS-2, CRS-2, HFE 90, or HFE 150; rapid curing liquid asphalt RC-70; or medium curing liquid asphalt MC-70 or MC-250.”

Revise Article 404.02 of the Standard Specifications to read:

“404.02 Materials. Materials shall be according to the following.

Item	Article/Section
(a) Cement	1001
(b) Water	1002
(c) Fine Aggregate	1003.08
(d) Bituminous Material (Tack Coat)	1032.06
(e) Emulsified Asphalts (Note 1) (Note 2)	1032.06
(f) Fiber Modified Joint Sealer	1050.05
(g) Additives (Note 3)	

Note 1. When used for slurry seal, the emulsified asphalt shall be CQS-1h according to Article 1032.06(b).

Note 2. When used for micro-surfacing, the emulsified asphalt shall be CQS-1hP according to Article 1032.06(e).

Note 3. Additives may be added to the emulsion mix or any of the component materials to provide the control of the quick-traffic properties. They shall be included as part of the mix design and be compatible with the other components of the mix.

Revise the last sentence of the fourth paragraph of Article 404.08 of the Standard Specifications to read:

“When approved by the Engineer, the sealant may be dusted with fine sand, cement, or mineral filler to prevent tracking.”

Revise Note 2 of Article 516.02 of the Standard Specifications to read:

“Note 2. The sand-cement grout mix shall be according to Section 1020 and shall be a 1:1 blend of sand and cement comprised of a Type I, IL, or II cement at 185 lb/cu yd (110 kg/cu m). The maximum water cement ratio shall be sufficient to provide a flowable mixture with a typical slump of 10 in. (250 mm).”

Revise Note 2 of Article 543.02 of the Standard Specifications to read:

“Note 2. The grout mixture shall be 6.50 hundredweight/cu yd (385 kg/cu m) of cement plus fine aggregate and water. Fly ash or ground granulated blast furnace (GGBF) slag may replace a maximum of 5.25 hundredweight/cu yd (310 kg/cu m) of the cement. The water/cement ratio, according to Article 1020.06, shall not exceed 0.60. An air-entraining admixture shall be used to produce an air content, according to Article 1020.08, of not less than 6.0 percent nor more than 9.0 percent of the volume of the grout. The Contractor shall have the option to use a water-reducing or high range water-reducing admixture.”

Revise Article 583.01 of the Standard Specifications to read:

“**583.01 Description.** This work shall consist of placing cement mortar along precast, prestressed concrete bridge deck beams as required for fairing out any unevenness between adjacent deck beams prior to placing of waterproofing membrane and surfacing.”

Revise Article 583.02(a) of the Standard Specifications to read:

“(a) Cement 1001”

Revise the first paragraph of Article 583.03 of the Standard Specifications to read:

“**583.03 General.** This work shall only be performed when the air temperature is 45 °F (7 °C) and rising. The mixture for cement mortar shall consist of three parts sand to one part cement by volume. The amount of water shall be no more than that necessary to produce a workable, plastic mortar.”

Revise Note 2/ in Article 1003.01(b) of the Standard Specifications to read:

"2/ Applies only to sand. Sand exceeding the colorimetric test standard of 11 (Illinois Modified AASHTO T 21) will be checked for mortar making properties according to Illinois Modified ASTM C 87 and shall develop a compressive strength at the age of 14 days when using Type I, IL, or II cement of not less than 95 percent of the comparable standard.

Revise the second sentence of Article 1003.02(e)(1) of the Standard Specifications to read:

"The test will be performed with Type I, IL, or II portland cement having a total equivalent alkali content ($\text{Na}_2\text{O} + 0.658\text{K}_2\text{O}$) of 0.90 percent or greater."

Revise the first sentence of the second paragraph of Article 1003.02(e)(3) of the Standard Specifications to read:

"The ASTM C 1293 test shall be performed with Type I, IL, or II portland cement having a total equivalent alkali content ($\text{Na}_2\text{O} + 0.658\text{K}_2\text{O}$) of 0.80 percent or greater."

Revise the second sentence of Article 1004.02(g)(1) of the Standard Specifications to read:

"The test will be performed with Type I, IL, or II portland cement having a total equivalent alkali content ($\text{Na}_2\text{O} + 0.658\text{K}_2\text{O}$) of 0.90 percent or greater."

Revise Article 1017.01 of the Standard Specifications to read:

"1017.01 Requirements. The mortar shall be high-strength according to ASTM C 387 and shall have a minimum 80.0 percent relative dynamic modulus of elasticity when tested by the Department according to Illinois Modified AASHTO T 161 or AASHTO T 161 when tested by an independent lab. The high-strength mortar shall have a water-soluble chloride ion content of less than 0.40 lb/cu yd (0.24 kg/cu m). The test shall be performed according to ASTM C 1218, and the high-strength mortar shall have an age of 28 to 42 days at the time of test. The ASTM C 1218 test shall be performed by an independent lab a minimum of once every five years, and the test results shall be provided to the Department. Mixing of the high-strength mortar shall be according to the manufacturer's specifications. The Department will maintain a qualified product list."

Revise the fourth sentence of Article 1018.01 of the Standard Specifications to read:

"The ASTM C 1218 test shall be performed by an independent lab a minimum of once every five years, and the test results shall be provided to the Department."

Revise Article 1019.02 of the Standard Specifications to read:

"1019.02 Materials. Materials shall be according to the following.

Item	Article/Section
(a) Cement	1001
(b) Water	1002
(c) Fine Aggregate for Controlled Low-Strength Material (CLSM).....	1003.06
(d) Fly Ash	1010
(e) Ground Granulated Blast Furnace (GGBF) Slag.....	1010
(f) Admixtures (Note 1)	

Note 1. The air-entraining admixture may be in powder or liquid form. Prior to approval, a CLSM air-entraining admixture will be evaluated by the Department. The admixture shall be able to meet the air content requirements of Mix 2. The Department will maintain a qualified product list.”

Revise Article 1019.05 of the Standard Specifications to read:

“**1019.05 Department Mix Design.** The Department mix design shall be Mix 1, 2, or 3 and shall be proportioned to yield approximately one cubic yard (cubic meter).

Mix 1	
Cement	50 lb (30 kg)
Fly Ash – Class C or F, and/or GGBF Slag	125 lb (74 kg)
Fine Aggregate – Saturated Surface Dry	2900 lb (1720 kg)
Water	50-65 gal (248-322 L)
Air Content	No air is entrained

Mix 2	
Cement	125 lb (74 kg)
Fine Aggregate – Saturated Surface Dry	2500 lb (1483 kg)
Water	35-50 gal (173-248 L)
Air Content	15-25 %

Mix 3	
Cement	40 lb (24 kg)
Fly Ash – Class C or F, and/or GGBF Slag	125 lb (74 kg)
Fine Aggregate – Saturated Surface Dry	2500 lb (1483 kg)
Water	35-50 gal (179-248 L)
Air Content	15-25 %”

Revise Article 1020.04, Table 1, Note (8) of the Standard Specifications to read:

“(8) In addition to the Type III portland cement, 100 lb/cu yd of ground granulated blast-furnace slag and 50 lb/cu yd of microsilica (silica fume) shall be used. For an air temperature greater than 85 °F, the Type III portland cement may be replaced with Type I, IL, or II portland cement.”

Revise Article 1020.04, Table 1 (Metric), Note (8) of the Standard Specifications to read:

“(8) In addition to the Type III portland cement, 60 kg/cu m of ground granulated blast-furnace slag and 30 kg/cu m of microsilica (silica fume) shall be used. For an air temperature greater than 30 °C, the Type III portland cement may be replaced with Type I, IL, or II portland cement.”

Revise the second paragraph of Article 1020.05(a) of the Standard Specifications to read:

“For a mix design using a portland-pozzolan cement, portland blast-furnace slag cement, portland-limestone cement, or replacing portland cement with finely divided minerals per Articles 1020.05(c) and 1020.05(d), the Contractor may submit a mix design with a minimum portland cement content less than 400 lbs/cu yd (237 kg/cu m), but not less than 375 lbs/cu yd (222 kg/cu m), if the mix design is shown to have a minimum relative dynamic modulus of elasticity of 80 percent determined according to AASHTO T 161. Testing shall be performed by an independent laboratory accredited by AASHTO re:source for Portland Cement Concrete.”

Revise the first sentence of the first paragraph of Article 1020.05(b) of the Standard Specifications to read:

“Corrosion inhibitors and concrete admixtures shall be according to the qualified product lists.”

Delete the fourth and fifth sentences of the second paragraph of Article 1020.05(b) of the Standard Specifications.

Revise the third sentence of the second paragraph of Article 1020.05(b)(5) of the Standard Specifications to read:

“The qualified product lists of concrete admixtures shall not apply.”

Revise second paragraph of Article 1020.05(b)(10) of the Standard Specifications to read:

“When calcium nitrite is used, it shall be added at the rate of 4 gal/cu yd (20 L/cu m) and shall be added to the mix immediately after all compatible admixtures have been introduced to the batch. Other corrosion inhibitors shall be added per the manufacturer’s specifications.”

Delete the third paragraph of Article 1020.05(b)(10) of the Standard Specifications.

Revise Article 1020.15(b)(1)c. of the Standard Specifications to read:

“c. The minimum portland cement content in the mixture shall be 375 lbs/cu yd (222 kg/cu m). When the total of organic processing additions, inorganic

processing additions, and limestone addition exceed 5.0 percent in the cement, the minimum portland cement content in the mixture shall be 400 lbs/cu yd (237 kg/cu m). For a drilled shaft, foundation, footing, or substructure, the minimum portland cement may be reduced to as low as 330 lbs/cu yd (196 kg/cu m) if the concrete has adequate freeze/thaw durability. The Contractor shall provide freeze/thaw test results according to AASHTO T 161, and the relative dynamic modulus of elasticity of the mix design shall be a minimum of 80 percent. Testing shall be performed by an independent laboratory accredited by AASHTO resource for Portland Cement Concrete. Freeze/thaw testing will not be required for concrete that will not be exposed to freezing and thawing conditions as determined by the Engineer.”

Revise Article 1021.01 of the Standard Specifications to read:

“**1021.01 General.** Admixtures shall be furnished in liquid or powder form ready for use. The admixtures shall be delivered in the manufacturer's original containers, bulk tank trucks or such containers or tanks as are acceptable to the Engineer. Delivery shall be accompanied by a ticket which clearly identifies the manufacturer, the date of manufacture, and trade name of the material. Containers shall be readily identifiable as to manufacturer, the date of manufacture, and trade name of the material they contain.

Concrete admixtures shall be on one of the Department's qualified product lists. Unless otherwise noted, admixtures shall have successfully completed and remain current with the AASHTO Product Eval and Audit Concrete Admixture (CADD) testing program. For admixture submittals to the Department; the product brand name, manufacturer name, admixture type or types, an electronic link to the product's technical data sheet, and the NTPEP testing number which contains an electronic link to all test data shall be provided. In addition, a letter shall be submitted certifying that no changes have been made in the formulation of the material since the most current round of tests conducted by AASHTO Product Eval and Audit. After 28 days of testing by AASHTO Product Eval and Audit, air-entraining admixtures may be provisionally approved and used on Departmental projects. For all other admixtures, unless otherwise noted, the time period after which provisionally approved status may be earned is 6 months.

The manufacturer shall include the following in the submittal to the AASHTO Product Eval and Audit CADD testing program: the manufacturing range for specific gravity, the midpoint and manufacturing range for residue by oven drying, and manufacturing range of pH. The submittal shall also include an infrared spectrophotometer trace no more than five years old.

For air-entraining admixtures according to Article 1021.02, the specific gravity allowable manufacturing range established by the manufacturer shall be according to AASHTO M 194. For residue by oven drying and pH, the allowable manufacturing range and test methods shall be according to AASHTO M 194.

For admixtures according to Articles 1021.03, 1021.04, 1021.05, 1021.06, 1021.07, and 1021.08, the pH allowable manufacturing range established by the manufacturer shall be

according to ASTM E 70. For specific gravity and residue by oven drying, the allowable manufacturing range and test methods shall be according to AASHTO M 194.

All admixtures, except chloride-based accelerators, shall contain a maximum of 0.3 percent chloride by weight (mass) as determined by an appropriate test method. To verify the test result, the Department will use Illinois Modified AASHTO T 260, Procedure A, Method 1.

Prior to final approval of an admixture, the Engineer reserves the right to request a sample for testing. The test and reference concrete mixtures tested by the Engineer will contain a cement content of 5.65 cwt/cu yd (335 kg/cu m). For freeze-thaw testing, the Department will perform the test according to Illinois Modified AASHTO T 161. The flexural strength test will be performed according to AASHTO T 177. If the Engineer decides to test the admixture, the manufacturer shall submit AASHTO T 197 water content and set time test results on the standard cement used by the Department. The manufacturer may select their lab or an independent lab to perform this testing. The laboratory is not required to be accredited by AASHTO.

Random field samples may be taken by the Department to verify an admixture meets specification. A split sample will be provided to the manufacturer if requested. Admixtures that do not meet specification requirements or an allowable manufacturing range established by the manufacturer shall be replaced with new material.”

Revise Article 1021.03 of the Standard Specifications to read:

“**1021.03 Retarding and Water-Reducing Admixtures.** The admixture shall be according to the following.

- (a) Retarding admixtures shall be according to AASHTO M 194, Type B (retarding) or Type D (water-reducing and retarding).
- (b) Water-reducing admixtures shall be according to AASHTO M 194, Type A.
- (c) High range water-reducing admixtures shall be according to AASHTO M 194, Type F (high range water-reducing) or Type G (high range water-reducing and retarding).”

Revise Article 1021.05 of the Standard Specifications to read:

“**1021.05 Self-Consolidating Admixtures.** Self-consolidating admixture systems shall consist of either a high range water-reducing admixture only or a high range water-reducing admixture combined with a separate viscosity modifying admixture. The one or two component admixture system shall be capable of producing a concrete that can flow around reinforcement and consolidate under its own weight without additional effort and without segregation.

High range water-reducing admixtures shall be according to AASHTO M 194, Type F.

Viscosity modifying admixtures shall be according to AASHTO M 194, Type S (specific performance).”

Revise Article 1021.06 of the Standard Specifications to read:

“1021.06 Rheology-Controlling Admixture. Rheology-controlling admixtures shall be capable of producing a concrete mixture with a lower yield stress that will consolidate easier for slipform applications used by the Contractor. Rheology-controlling admixtures shall be according to AASHTO M 194, Type S (specific performance).”

Revise Article 1021.07 of the Standard Specifications to read:

“1021.07 Corrosion Inhibitor. The corrosion inhibitor shall be according to one of the following.

- (a) Calcium Nitrite. Corrosion inhibitors shall contain a minimum 30 percent calcium nitrite by weight (mass) of solution and shall comply with either the requirements of AASHTO M 194, Type C (accelerating) or the requirements of ASTM C 1582. The corrosion inhibiting performance requirements of ASTM C 1582 shall not apply.
- (b) Other Materials. The corrosion inhibitor shall be according to ASTM C 1582.

For submittals requiring testing according to ASTM M 194, Type C (accelerating), the admixture shall meet the requirements of the AASHTO Product Eval and Audit CADD testing program according to Article 1021.01.

For submittals requiring testing according to ASTM C 1582, a report prepared by an independent laboratory accredited by AASHTO re:source for portland cement concrete shall be provided. The report shall show the results of physical tests conducted no more than five years prior to the time of submittal, according to applicable specifications. However, ASTM G 109 test information specified in ASTM C 1582 is not required to be from an independent accredited lab. All other information in ASTM C 1582 shall be from an independent accredited lab. Test data and other information required to be submitted to AASHTO Product Eval and Audit according to Article 1021.01, shall instead be submitted directly to the Department.”

Add Article 1021.08 of the Standard Specifications as follows:

“1021.08 Other Specific Performance Admixtures. Other specific performance admixtures shall, at a minimum, be according to AASHTO M 194, Type S (specific performance). The Department also reserves the right to require other testing, as determined by the Engineer, to show evidence of specific performance characteristics.

Initial testing according to AASHTO M 194 may be conducted under the AASHTO Product Eval and Audit CADD testing program according to Article 1021.01, or by an independent laboratory accredited by AASHTO re:source for Portland Cement Concrete. In either case, test data and other information required to be submitted to AASHTO Product Eval and Audit according to Article 1021.01, shall also be submitted directly to the Department. The independent

accredited lab report shall show the results of physical tests conducted no more than five years prior to the time of submittal, according to applicable specifications.”

Revise Article 1024.01 of the Standard Specifications to read:

“**1024.01 Requirements for Grout.** The grout shall be proportioned by dry volume, thoroughly mixed, and shall have a minimum temperature of 50 °F (10 °C). Water shall not exceed the minimum needed for placement and finishing.

Materials for the grout shall be according to the following.

Item	Article/Section
(a) Cement	1001
(b) Water	1002
(c) Fine Aggregate	1003.02
(d) Fly Ash	1010
(e) Ground Granulated Blast Furnace (GGBF) Slag.....	1010
(f) Concrete Admixtures	1021”

Revise Note 1 of Article 1024.02 of the Standard Specifications to read:

“Note 1. Nonshrink grout shall be according to Illinois Modified ASTM C 1107.

The nonshrink grout shall have a water-soluble chloride ion content of less than 0.40 lb/cu yd (0.24 kg/cu m). The test shall be performed according to ASTM C 1218, and the grout shall have an age of 28 to 42 days at the time of test. The ASTM C 1218 test shall be performed by an independent lab a minimum of once every five years, and the test results shall be provided to the Department. Mixing of the nonshrink grout shall be according to the manufacturer’s specifications. The Department will maintain a qualified product list.”

Revise Article 1029.02 of the Standard Specifications to read:

“**1029.02 Materials.** Materials shall be according to the following.

Item	Article/Section
(a) Cement.....	1001
(b) Fly Ash	1010
(c) Ground Granulated Blast Furnace (GGBF) Slag	1010
(d) Water.....	1002
(e) Fine Aggregate.....	1003
(f) Concrete Admixtures.....	1021
(g) Foaming Agent (Note 1)	

Note 1. The manufacturer shall submit infrared spectrophotometer trace and test results indicating the foaming agent meets the requirements of ASTM C 869 in order to be on the

Department's qualified product list. Submitted data/results shall not be more than five years old."

Revise the second paragraph of Article 1103.03(a)(4) the Standard Specifications to read:

"The dispenser system shall provide a visual indication that the liquid admixture is actually entering the batch, such as via a transparent or translucent section of tubing or by independent check with an integrated secondary metering device. If approved by the Engineer, an alternate indicator may be used for admixtures dosed at rates of 25 oz/cwt (1630 mL/100 kg) or greater, such as accelerating admixtures, corrosion inhibitors, and viscosity modifying admixtures."

Revise the first two sections of Check Sheet #11 of the Supplemental Specifications and Recurring Special Provisions to read:

Description. This work shall consist of filling voids beneath rigid and composite pavements with cement grout.

Materials. Materials shall be according to the following Articles of Division 1000 - Materials of the Standard Specifications:

Item	Article/Section
(a) Cement	1001
(b) Water	1002
(c) Fly Ash	1010
(d) Ground Granulated Blast Furnace (GGBF) Slag.....	1010
(e) Admixtures	1021
(f) Packaged Rapid Hardening Mortar or Concrete	1018"

Revise the third paragraph of Materials Note 2 of Check Sheet #28 of the Supplemental Specifications and Recurring Special Provisions to read:

"The Department will maintain a qualified product list of synthetic fibers, which will include the minimum required dosage rate. For the minimum required fiber dosage rate based on the Illinois Modified ASTM C 1609 test, a report prepared by an independent laboratory accredited by AASHTO re:source for Portland Cement Concrete shall be provided. The report shall show results of tests conducted no more than five years prior to the time of submittal."

COMPENSABLE DELAY COSTS (BDE)

Effective: June 2, 2017

Revised: April 1, 2019

Revise Article 107.40(b) of the Standard Specifications to read:

“(b) Compensation. Compensation will not be allowed for delays, inconveniences, or damages sustained by the Contractor from conflicts with facilities not meeting the above definition; or if a conflict with a utility in an unanticipated location does not cause a shutdown of the work or a documentable reduction in the rate of progress exceeding the limits set herein. The provisions of Article 104.03 notwithstanding, compensation for delays caused by a utility in an unanticipated location will be paid according to the provisions of this Article governing minor and major delays or reduced rate of production which are defined as follows.

- (1) Minor Delay. A minor delay occurs when the work in conflict with the utility in an unanticipated location is completely stopped for more than two hours, but not to exceed two weeks.
- (2) Major Delay. A major delay occurs when the work in conflict with the utility in an unanticipated location is completely stopped for more than two weeks.
- (3) Reduced Rate of Production Delay. A reduced rate of production delay occurs when the rate of production on the work in conflict with the utility in an unanticipated location decreases by more than 25 percent and lasts longer than seven calendar days.”

Revise Article 107.40(c) of the Standard Specifications to read:

“(c) Payment. Payment for Minor, Major, and Reduced Rate of Production Delays will be made as follows.

- (1) Minor Delay. Labor idled which cannot be used on other work will be paid for according to Article 109.04(b)(1) and (2) for the time between start of the delay and the minimum remaining hours in the work shift required by the prevailing practice in the area.

Equipment idled which cannot be used on other work, and which is authorized to standby on the project site by the Engineer, will be paid for according to Article 109.04(b)(4).

- (2) Major Delay. Labor will be the same as for a minor delay.

Equipment will be the same as for a minor delay, except Contractor-owned equipment will be limited to two weeks plus the cost of move-out to either the Contractor's yard or another job and the cost to re-mobilize, whichever is less. Rental equipment may be paid for longer than two weeks provided the Contractor presents adequate support to the Department (including lease agreement) to show retaining equipment on the job is the most economical course to follow and in the public interest.

- (3) **Reduced Rate of Production Delay.** The Contractor will be compensated for the reduced productivity for labor and equipment time in excess of the 25 percent threshold for that portion of the delay in excess of seven calendar days. Determination of compensation will be in accordance with Article 104.02, except labor and material additives will not be permitted.

Payment for escalated material costs, escalated labor costs, extended project overhead, and extended traffic control will be determined according to Article 109.13."

Revise Article 108.04(b) of the Standard Specifications to read:

"(b) No working day will be charged under the following conditions.

- (1) When adverse weather prevents work on the controlling item.
- (2) When job conditions due to recent weather prevent work on the controlling item.
- (3) When conduct or lack of conduct by the Department or its consultants, representatives, officers, agents, or employees; delay by the Department in making the site available; or delay in furnishing any items required to be furnished to the Contractor by the Department prevents work on the controlling item.
- (4) When delays caused by utility or railroad adjustments prevent work on the controlling item.
- (5) When strikes, lock-outs, extraordinary delays in transportation, or inability to procure critical materials prevent work on the controlling item, as long as these delays are not due to any fault of the Contractor.
- (6) When any condition over which the Contractor has no control prevents work on the controlling item."

Revise Article 109.09(f) of the Standard Specifications to read:

- "(f) **Basis of Payment.** After resolution of a claim in favor of the Contractor, any adjustment in time required for the work will be made according to Section 108. Any adjustment in the costs to be paid will be made for direct labor, direct materials, direct equipment, direct jobsite overhead, direct offsite overhead, and other direct costs allowed by the

resolution. Adjustments in costs will not be made for interest charges, loss of anticipated profit, undocumented loss of efficiency, home office overhead and unabsorbed overhead other than as allowed by Article 109.13, lost opportunity, preparation of claim expenses and other consequential indirect costs regardless of method of calculation.

The above Basis of Payment is an essential element of the contract and the claim cost recovery of the Contractor shall be so limited.”

Add the following to Section 109 of the Standard Specifications.

“109.13 Payment for Contract Delay. Compensation for escalated material costs, escalated labor costs, extended project overhead, and extended traffic control will be allowed when such costs result from a delay meeting the criteria in the following table.

Contract Type	Cause of Delay	Length of Delay
Working Days	Article 108.04(b)(3) or Article 108.04(b)(4)	No working days have been charged for two consecutive weeks.
Completion Date	Article 108.08(b)(1) or Article 108.08(b)(7)	The Contractor has been granted a minimum two week extension of contract time, according to Article 108.08.

Payment for each of the various costs will be according to the following.

- (a) Escalated Material and/or Labor Costs. When the delay causes work, which would have otherwise been completed, to be done after material and/or labor costs have increased, such increases will be paid. Payment for escalated material costs will be limited to the increased costs substantiated by documentation furnished by the Contractor. Payment for escalated labor costs will be limited to those items in Article 109.04(b)(1) and (2), except the 35 percent and 10 percent additives will not be permitted.
- (b) Extended Project Overhead. For the duration of the delay, payment for extended project overhead will be paid as follows.
 - (1) Direct Jobsite and Offsite Overhead. Payment for documented direct jobsite overhead and documented direct offsite overhead, including onsite supervisory and administrative personnel, will be allowed according to the following table.

Original Contract Amount	Supervisory and Administrative Personnel
Up to \$5,000,000	One Project Superintendent
Over \$ 5,000,000 - up to \$25,000,000	One Project Manager, One Project Superintendent or Engineer, and One Clerk
Over \$25,000,000 -	One Project Manager,

up to \$50,000,000	One Project Superintendent, One Engineer, and One Clerk
Over \$50,000,000	One Project Manager, Two Project Superintendents, One Engineer, and One Clerk

(2) Home Office and Unabsorbed Overhead. Payment for home office and unabsorbed overhead will be calculated as 8 percent of the total delay cost.

(c) Extended Traffic Control. Traffic control required for an extended period of time due to the delay will be paid for according to Article 109.04.

When an extended traffic control adjustment is paid under this provision, an adjusted unit price as provided for in Article 701.20(a) for increase or decrease in the value of work by more than ten percent will not be paid.

Upon payment for a contract delay under this provision, the Contractor shall assign subrogation rights to the Department for the Department's efforts of recovery from any other party for monies paid by the Department as a result of any claim under this provision. The Contractor shall fully cooperate with the Department in its efforts to recover from another party any money paid to the Contractor for delay damages under this provision."

80384

CONSTRUCTION AIR QUALITY – DIESEL RETROFIT (BDE)

Effective: June 1, 2010

Revised: January 1, 2025

The reduction of emissions of particulate matter (PM) for off-road equipment shall be accomplished by installing retrofit emission control devices. The term “equipment” refers to diesel fuel powered devices rated at 50 hp and above, to be used on the jobsite in excess of seven calendar days over the course of the construction period on the jobsite (including rental equipment).

Contractor and subcontractor diesel powered off-road equipment assigned to the contract shall be retrofitted according to the table below.

Horsepower Range	Model Year and Older
50-99	2003
100-299	2002
300-599	2000
600-749	2001
750 and up	2005

The retrofit emission control devices shall achieve a minimum PM emission reduction of 50 percent and shall be:

- a) Included on the U.S. Environmental Protection Agency (USEPA) *Verified Retrofit Technology List* (<https://www.epa.gov/verified-diesel-tech/verified-technologies-list-clean-diesel>), or verified by the California Air Resources Board (CARB) (<http://www.arb.ca.gov/diesel/verdev/vt/cvt.htm>); or
- b) Retrofitted with a non-verified diesel retrofit emission control device if verified retrofit emission control devices are not available for equipment proposed to be used on the project, and if the Contractor has obtained a performance certification from the retrofit device manufacturer that the emission control device provides a minimum PM emission reduction of 50 percent.

Note: Large cranes (Crawler mounted cranes) which are responsible for critical lift operations are exempt from installing retrofit emission control devices if such devices adversely affect equipment operation.

Diesel powered off-road equipment with engine ratings of 50 hp and above, which are unable to be retrofitted with verified emission control devices or if performance certifications are not available which will achieve a minimum 50 percent PM reduction, may be granted a waiver by the Department if documentation is provided showing good faith efforts were made by the Contractor to retrofit the equipment.

Construction shall not proceed until the Contractor submits a certified list of the diesel powered off-road equipment that will be used, and as necessary, retrofitted with emission control devices. The list(s) shall include (1) the equipment number, type, make, Contractor/rental company name; and (2) the emission control devices make, model, USEPA or CARB verification number, or performance certification from the retrofit device manufacturer. Equipment reported as fitted with emissions control devices shall be made available to the Engineer for visual inspection of the device installation, prior to being used on the jobsite.

The Contractor shall submit an updated list of retrofitted off-road construction equipment as retrofitted equipment changes or comes on to the jobsite. The addition or deletion of any diesel powered equipment shall be included on the updated list.

If any diesel powered off-road equipment is found to be in non-compliance with any portion of this special provision, the Engineer will issue the Contractor a diesel retrofit deficiency deduction.

Any costs associated with retrofitting any diesel powered off-road equipment with emission control devices shall be considered as included in the contract unit prices bid for the various items of work involved and no additional compensation will be allowed. The Contractor's compliance with this notice and any associated regulations shall not be grounds for a claim.

Diesel Retrofit Deficiency Deduction

When the Engineer determines that a diesel retrofit deficiency exists, a daily monetary deduction will be imposed for each calendar day or fraction thereof the deficiency continues to exist. The calendar day(s) will begin when the time period for correction is exceeded and end with the Engineer's written acceptance of the correction. The daily monetary deduction will be \$1,000.00 for each deficiency identified.

The deficiency will be based on lack of diesel retrofit emissions control.

If a Contractor accumulates three diesel retrofit deficiency deductions for the same piece of equipment in a contract period, the Contractor will be shutdown until the deficiency is corrected. Such a shutdown will not be grounds for any extension of the contract time, waiver of penalties, or be grounds for any claim.

HOT-MIX ASPHALT – LONGITUDINAL JOINT SEALANT (BDE)

Effective: November 1, 2022

Revised: August 1, 2023

Add the following after the second sentence in the eighth paragraph of Article 406.06(h)(2) of the Standard Specifications:

“If rain is forecasted and traffic is to be on the LJS or if pickup/tracking of the LJS material is likely, the LJS shall be covered immediately following its application with FA 20 fine aggregate mechanically spread uniformly at a rate of 1.5 ± 0.5 lb/sq yd (0.75 ± 0.25 kg/sq m). Fine aggregate landing outside of the LJS shall be removed prior to application of tack coat.”

Add the following after the first sentence in the ninth paragraph of Article 406.06(h)(2) of the Standard Specifications:

“LJS half-width shall be applied at a width of 9 ± 1 in. (225 ± 25 mm) in the immediate lane to be placed with the outside edge flush with the joint of the next HMA lift. The vertical face of any longitudinal joint remaining in place shall also be coated.”

Add the following after the eleventh paragraph of Article 406.06(h)(2) of the Standard Specifications:

“LJS Half-Width Application Rate, lb/ft (kg/m) ^{1/}			
Lift Thickness, in. (mm)	Coarse Graded Mixture (IL-19.0, IL-19.0L, IL-9.5, IL-9.5L, IL-4.75)	Fine Graded Mixture (IL-9.5FG)	SMA Mixture (SMA-9.5, SMA-12.5)
$\frac{3}{4}$ (19)	0.44 (0.66)		
1 (25)	0.58 (0.86)		
1 $\frac{1}{4}$ (32)	0.66 (0.98)	0.44 (0.66)	
1 $\frac{1}{2}$ (38)	0.74 (1.10)	0.48 (0.71)	0.63 (0.94)
1 $\frac{3}{4}$ (44)	0.82 (1.22)	0.52 (0.77)	0.69 (1.03)
2 (50)	0.90 (1.34)	0.56 (0.83)	0.76 (1.13)
$\geq 2 \frac{1}{4}$ (60)	0.98 (1.46)		

1/ The application rate includes a surface demand for liquid. The thickness of the LJS may taper from the center of the application to a lesser thickness on the edge of the application, provided the correct width and application rate are maintained.”

Revise the second paragraph of Article 406.13(b) of the Standard Specifications to read:

“Aggregate for covering tack, LJS, or FLS will not be measured for payment.”

Add the following to the end of the second paragraph of Article 406.14 of the Standard Specifications:

“Longitudinal joint sealant (LJS) half-width will be paid for at the contract unit price per foot (meter) for LONGITUDINAL JOINT SEALANT, HALF-WIDTH.”

80446

NOT FOR BID

PAVEMENT PATCHING (BDE)

Effective: August 1, 2025

Revise the first sentence of the last paragraph of Article 442.06(a)(2) of the Standard Specifications to read:

“Type IV patches shall be reinforced with welded wire reinforcement according to the details shown on the plans.”

Revise Article 442.06(a)(3) of the Standard Specifications to read:

“(3) Class C Patching. Patches adjacent to a new lane of pavement, new portland cement concrete shoulder, or new curb and gutter of more than 20 ft (6 m) in length shall be tied with No. 6 (No. 19) tie bars, 24 in. (600 mm) long, embedded 8 in. (200 mm) at 36 in. (900 mm) centers according to Article 420.05(b).

When the patched pavement is not to be resurfaced, transverse contraction joints shall be formed on 15 ft (4.5 m) to 20 ft (6 m) centers by sawing in all patches that are more than 20 ft (6 m) in length. They shall be placed in line with joints or cracks in the existing slab whenever possible.”

Revise the eighth paragraph of Article 442.11 of the Standard Specifications to read:

“Pavement tie bars for patches will be paid for at the contract unit price per each for TIE BARS, of the diameter specified.”

80468

PERFORMANCE GRADED ASPHALT BINDER (BDE)

Effective: January 1, 2023

Revise Article 1032.05 of the Standard Specifications to read:

“1032.05 Performance Graded Asphalt Binder. These materials will be accepted according to the Bureau of Materials Policy Memorandum, “Performance Graded Asphalt Binder Qualification Procedure.” The Department will maintain a qualified producer list. These materials shall be free from water and shall not foam when heated to any temperature below the actual flash point. Air blown asphalt, recycle engine oil bottoms (ReOB), and polyphosphoric acid (PPA) modification shall not be used.

When requested, producers shall provide the Engineer with viscosity/temperature relationships for the performance graded asphalt binders delivered and incorporated in the work.

- (a) Performance Graded (PG) Asphalt Binder. The asphalt binder shall meet the requirements of AASHTO M 320, Table 1 “Standard Specification for Performance Graded Asphalt Binder” for the grade shown on the plans and the following.

Test	Parameter
Small Strain Parameter (AASHTO PP 113) BBR, ΔT_c , 40 hrs PAV (40 hrs continuous or 2 PAV at 20 hrs)	-5 °C min.

- (b) Modified Performance Graded (PG) Asphalt Binder. The asphalt binder shall meet the requirements of AASHTO M 320, Table 1 “Standard Specification for Performance Graded Asphalt Binder” for the grade shown on the plans.

Asphalt binder modification shall be performed at the source, as defined in the Bureau of Materials Policy Memorandum, “Performance Graded Asphalt Binder Qualification Procedure.”

Modified asphalt binder shall be safe to handle at asphalt binder production and storage temperatures or HMA construction temperatures. Safety Data Sheets (SDS) shall be provided for all asphalt modifiers.

- (1) Polymer Modification (SB/SBS or SBR). Elastomers shall be added to the base asphalt binder to achieve the specified performance grade and shall be either a styrene-butadiene diblock, triblock copolymer without oil extension, or a styrene-butadiene rubber. The polymer modified asphalt binder shall be smooth, homogeneous, and be according to the requirements shown in Table 1 or 2 for the grade shown on the plans.

Table 1 - Requirements for Styrene-Butadiene Copolymer (SB/SBS) Modified Asphalt Binders		
Test	Asphalt Grade SB/SBS PG 64-28 SB/SBS PG 70-22	Asphalt Grade SB/SBS PG 64-34 SB/SBS PG 70-28 SB/SBS PG 76-22 SB/SBS PG 76-28
Separation of Polymer ITP, "Separation of Polymer from Asphalt Binder" Difference in °F (°C) of the softening point between top and bottom portions	4 (2) max.	4 (2) max.
TESTS ON RESIDUE FROM ROLLING THIN FILM OVEN TEST (AASHTO T 240)		
Elastic Recovery ASTM D 6084, Procedure A, 77 °F (25 °C), 100 mm elongation, %	60 min.	70 min.

Table 2 - Requirements for Styrene-Butadiene Rubber (SBR) Modified Asphalt Binders		
Test	Asphalt Grade SBR PG 64-28 SBR PG 70-22	Asphalt Grade SB/SBS PG 64-34 SB/SBS PG 70-28 SBR PG 76-22 SBR PG 76-28
Separation of Polymer ITP, "Separation of Polymer from Asphalt Binder" Difference in °F (°C) of the softening point between top and bottom portions	4 (2) max.	4 (2) max.
Toughness ASTM D 5801, 77 °F (25 °C), 20 in./min. (500 mm/min.), in.-lbs (N-m)	110 (12.5) min.	110 (12.5) min.
Tenacity ASTM D 5801, 77 °F (25 °C), 20 in./min. (500 mm/min.), in.-lbs (N-m)	75 (8.5) min.	75 (8.5) min.
TESTS ON RESIDUE FROM ROLLING THIN FILM OVEN TEST (AASHTO T 240)		
Elastic Recovery ASTM D 6084, Procedure A, 77 °F (25 °C), 100 mm elongation, %	40 min.	50 min.

- (2) Ground Tire Rubber (GTR) Modification. GTR modification is the addition of recycled ground tire rubber to liquid asphalt binder to achieve the specified performance grade. GTR shall be produced from processing automobile and/or truck tires by the ambient

grinding method or micronizing through a cryogenic process. GTR shall not exceed 1/16 in. (2 mm) in any dimension and shall not contain free metal particles, moisture that would cause foaming of the asphalt, or other foreign materials. A mineral powder (such as talc) meeting the requirements of AASHTO M 17 may be added, up to a maximum of four percent by weight of GTR to reduce sticking and caking of the GTR particles. When tested in accordance with Illinois Modified AASHTO T 27 “Standard Method of Test for Sieve Analysis of Fine and Coarse Aggregates” or AASHTO PP 74 “Standard Practice for Determination of Size and Shape of Glass Beads Used in Traffic Markings by Means of Computerized Optical Method”, a 50 g sample of the GTR shall conform to the following gradation requirements.

Sieve Size	Percent Passing
No. 16 (1.18 mm)	100
No. 30 (600 µm)	95 ± 5
No. 50 (300 µm)	> 20

GTR modified asphalt binder shall be tested for rotational viscosity according to AASHTO T 316 using spindle S27. GTR modified asphalt binder shall be tested for original dynamic shear and RTFO dynamic shear according to AASHTO T 315 using a gap of 2 mm.

The GTR modified asphalt binder shall meet the requirements of Table 3.

Table 3 - Requirements for Ground Tire Rubber (GTR) Modified Asphalt Binders		
Test	Asphalt Grade GTR PG 64-28 GTR PG 70-22	Asphalt Grade GTR PG 76-22 GTR PG 76-28 GTR PG 70-28
TESTS ON RESIDUE FROM ROLLING THIN FILM OVEN TEST (AASHTO T 240)		
Elastic Recovery ASTM D 6084, Procedure A, 77 °F (25 °C), 100 mm elongation, %	60 min.	70 min.

- (3) Softener Modification (SM). Softener modification is the addition of organic compounds, such as engineered flux, bio-oil blends, modified vegetable oils, glycol amines, and fatty acid derivatives, to the base asphalt binder to achieve the specified performance grade. Softeners shall be dissolved, dispersed, or reacted in the asphalt binder to enhance its performance and shall remain compatible with the asphalt binder with no separation. Softeners shall not be added to modified PG asphalt binder as defined in Articles 1032.05(b)(1) or 1032.05(b)(2).

An Attenuated Total Reflectance-Fourier Transform Infrared spectrum (ATR-FTIR) shall be collected for both the softening compound as well as the softener modified

asphalt binder at the dose intended for qualification. The ATR-FTIR spectra shall be collected on unaged softener modified binder, 20-hour Pressurized Aging Vessel (PAV) aged softener modified binder, and 40-hour PAV aged softener modified binder. The ATR-FTIR shall be collected in accordance with Illinois Test Procedure 601. The electronic files spectral files (in one of the following extensions or equivalent: *.SPA, *.SPG, *.IRD, *.IFG, *.CSV, *.SP, *.IRS, *.GAML, *. [0-9], *.IGM, *.ABS, *.DRT, *.SBM, *.RAS) shall be submitted to the Central Bureau of Materials.

Softener modified asphalt binders shall meet the requirements in Table 4.

Test	Asphalt Grade	
	SM PG 46-28	SM PG 46-34
	SM PG 52-28	SM PG 52-34
	SM PG 58-22	SM PG 58-28
	SM PG 64-22	
Small Strain Parameter (AASHTO PP 113) BBR, ΔT_c , 40 hrs PAV (40 hrs continuous or 2 PAV at 20 hrs)	-5°C min.	
Large Strain Parameter (Illinois Modified AASHTO T 391) DSR/LAS Fatigue Property, $\Delta G^* _{peak}$, 40 hrs PAV (40 hrs continuous or 2 PAV at 20 hrs)	≥ 54 %	

The following grades may be specified as tack coats.

Asphalt Grade	Use
PG 58-22, PG 58-28, PG 64-22	Tack Coat

Revise Article 1031.06(c)(1) and 1031.06(c)(2) of the Standard Specifications to read:

“(1) RAP/RAS. When RAP is used alone or RAP is used in conjunction with RAS, the percentage of virgin ABR shall not exceed the amounts listed in the following table.

Ndesign	Binder	Surface	Polymer Modified Binder or Surface ^{3/}
30	30	30	10
50	25	15	10
70	15	10	10
90	10	10	10

1/ For Low ESAL HMA shoulder and stabilized subbase, the RAP/RAS ABR shall not exceed 50 percent of the mixture.

- 2/ When RAP/RAS ABR exceeds 20 percent, the high and low virgin asphalt binder grades shall each be reduced by one grade (i.e. 25 percent ABR would require a virgin asphalt binder grade of PG 64-22 to be reduced to a PG 58-28).
 - 3/ The maximum ABR percentages for ground tire rubber (GTR) modified mixes shall be equivalent to the percentages specified for SBS/SBR polymer modified mixes.
- (2) FRAP/RAS. When FRAP is used alone or FRAP is used in conjunction with RAS, the percentage of virgin asphalt binder replacement shall not exceed the amounts listed in the following table.

HMA Mixtures - FRAP/RAS Maximum ABR % ^{1/ 2/}			
Ndesign	Binder	Surface	Polymer Modified Binder or Surface ^{3/}
30	55	45	15
50	45	40	15
70	45	35	15
90	45	35	15
SMA	--	--	25
IL-4.75	--	--	35

- 1/ For Low ESAL HMA shoulder and stabilized subbase, the FRAP/RAS ABR shall not exceed 50 percent of the mixture.
- 2/ When FRAP/RAS ABR exceeds 20 percent for all mixes, the high and low virgin asphalt binder grades shall each be reduced by one grade (i.e. 25 percent ABR would require a virgin asphalt binder grade of PG 64-22 to be reduced to a PG 58-28).
- 3/ The maximum ABR percentages for GTR modified mixes shall be equivalent to the percentages specified for SBS/SBR polymer modified mixes.”

Add the following to the end of Note 2 of Article 1030.03 of the Standard Specifications.

“A dedicated storage tank for the ground tire rubber (GTR) modified asphalt binder shall be provided. This tank shall be capable of providing continuous mechanical mixing throughout and/or recirculation of the asphalt binder to provide a uniform mixture. The tank shall be heated and capable of maintaining the temperature of the asphalt binder at 300 °F to 350 °F (149 °C to 177 °C). The asphalt binder metering systems of dryer drum plants shall be calibrated with the actual GTR modified asphalt binder material with an accuracy of ±0.40 percent.”

REMOVAL AND DISPOSAL OF REGULATED SUBSTANCES (BDE)

Effective: January 1, 2024

Revised: April 1, 2024

Revise the first paragraph of Article 669.04 of the Standard Specifications to read:

“669.04 Regulated Substances Monitoring. Regulated substances monitoring includes environmental observation and field screening during regulated substances management activities. The excavated soil and groundwater within the work areas shall be managed as either uncontaminated soil, hazardous waste, special waste, or non-special waste.

As part of the regulated substances monitoring, the monitoring personnel shall perform and document the applicable duties listed on form BDE 2732 “Regulated Substances Monitoring Daily Record (RSMDR)”.”

Revise the first two sentences of the nineteenth paragraph of Article 669.05 of the Standard Specifications to read:

“The Contractor shall coordinate waste disposal approvals with the disposal facility and provide the specific analytical testing requirements of that facility. The Contractor shall make all arrangements for collection, transportation, and analysis of landfill acceptance testing.”

Revise the last paragraph of Article 669.05 of the Standard Specifications to read:

“The Contractor shall select a permitted landfill facility or CCDD/USFO facility meeting the requirements of 35 Ill. Admin. Code Parts 810-814 or Part 1100, respectively. The Department will review and approve or reject the facility proposed by the Contractor based upon information provided in BDE 2730. The Contractor shall verify whether the selected facility is compliant with those applicable standards as mandated by their permit and whether the facility is presently, has previously been, or has never been, on the United States Environmental Protection Agency (U.S. EPA) National Priorities List or the Resource Conservation and Recovery Act (RCRA) List of Violating Facilities. The use of a Contractor selected facility shall in no manner delay the construction schedule or alter the Contractor's responsibilities as set forth.”

Revise the first paragraph of Article 669.07 of the Standard Specifications to read:

“669.07 Temporary Staging. Soil classified according to Articles 669.05(a)(2), (b)(1), or (c) may be temporarily staged at the Contractor's option. All other soil classified according to Articles 669.05(a)(1), (a)(3), (a)(4), (a)(5), (a)(6), or (b)(2) shall be managed and disposed of without temporary staging to the greatest extent practicable. If circumstances beyond the Contractor's control require temporary staging of these latter materials, the Contractor shall request approval from the Engineer in writing.

Topsoil for re-use as final cover which has been field screened and found not to exhibit PID readings over daily background readings as documented on the BDE 2732, visual staining or odors, and is classified according to Articles 669.05(a)(2), (a)(3), (a)(4), (b)(1), or (c) may be temporarily staged at the Contractor's option."

Add the following paragraph after the sixth paragraph of Article 669.11 of the Standard Specifications.

"The sampling and testing of effluent water derived from dewatering discharges for priority pollutants volatile organic compounds (VOCs), priority pollutants semi-volatile organic compounds (SVOCs), or priority pollutants metals, will be paid for at the contract unit price per each for VOCS GROUNDWATER ANALYSIS using EPA Method 8260B, SVOCs GROUNDWATER ANALYSIS using EPA Method 8270C, or RCRA METALS GROUNDWATER ANALYSIS using EPA Methods 6010B and 7471A. This price shall include transporting the sample from the job site to the laboratory."

Revise the first sentence of the eight paragraph of Article 669.11 of the Standard Specifications to read:

"Payment for temporary staging of soil classified according to Articles 669.05(a)(1), (a)(3), (a)(4), (a)(5), (a)(6), or (b)(2) to be managed and disposed of, if required and approved by the Engineer, will be paid according to Article 109.04."

80455

VEHICLE AND EQUIPMENT WARNING LIGHTS (BDE)

Effective: November 1, 2021

Revised: November 1, 2022

Add the following paragraph after the first paragraph of Article 701.08 of the Standard Specifications:

“The Contractor shall equip all vehicles and equipment with high-intensity oscillating, rotating, or flashing, amber or amber-and-white, warning lights which are visible from all directions. In accordance with 625 ILCS 5/12-215, the lights may only be in operation while the vehicle or equipment is engaged in construction operations.”

80439

WORK ZONE TRAFFIC CONTROL DEVICES (BDE)

Effective: March 2, 2020

Revised: January 1, 2025

Add the following to Article 701.03 of the Standard Specifications:

“(q) Temporary Sign Supports 1106.02”

Revise the third paragraph of Article 701.14 of the Standard Specifications to read:

“For temporary sign supports, the Contractor shall provide a FHWA eligibility letter for each device used on the contract. The letter shall provide information for the set-up and use of the device as well as a detailed drawing of the device. The signs shall be supported within 20 degrees of vertical. Weights used to stabilize signs shall be attached to the sign support per the manufacturer’s specifications.”

Revise the first paragraph of Article 701.15 of the Standard Specifications to read:

“**701.15 Traffic Control Devices.** For devices that must meet crashworthiness standards, the Contractor shall provide a manufacturer’s self-certification or a FHWA eligibility letter for each Category 1 device and a FHWA eligibility letter for each Category 2 and Category 3 device used on the contract. The self-certification or letter shall provide information for the set-up and use of the device as well as a detailed drawing of the device.”

Revise the first six paragraphs of Article 1106.02 of the Standard Specifications to read:

“**1106.02 Devices.** Work zone traffic control devices and combinations of devices shall meet crashworthiness standards for their respective categories. The categories are as follows.

Category 1 includes small, lightweight, channelizing and delineating devices that have been in common use for many years and are known to be crashworthy by crash testing of similar devices or years of demonstrable safe performance. These include cones, tubular markers, plastic drums, and delineators, with no attachments (e.g. lights). Category 1 devices shall be MASH compliant.

Category 2 includes devices that are not expected to produce significant vehicular velocity change but may otherwise be hazardous. These include vertical panels with lights, barricades, temporary sign supports, and Category 1 devices with attachments (e.g. drums with lights). Category 2 devices shall be MASH compliant.

Category 3 includes devices that are expected to cause significant velocity changes or other potentially harmful reactions to impacting vehicles. These include crash cushions (impact attenuators), truck mounted attenuators, and other devices not meeting the definitions of Category 1 or 2. Category 3 devices manufactured after December 31, 2019 shall be MASH

compliant. Category 3 devices manufactured on or before December 31, 2019, and compliant with NCHRP 350, may be used on contracts let before December 31, 2029. Category 3 devices shall be crash tested for Test Level 3 or the test level specified.

Category 4 includes portable or trailer-mounted devices such as sign supports, speed feedback displays, arrow boards, changeable message signs, temporary traffic signals, and area lighting supports. It is preferable for Category 4 devices manufactured after December 31, 2019 to be MASH-16 compliant; however, there are currently no crash tested devices in this category, so it remains exempt from the NCHRP 350 or MASH compliance requirement.

For each type of device, when no more than one MASH compliant is available, an NCHRP 350 compliant device may be used, even if manufactured after December 31, 2019.”

Revise Articles 1106.02(g), 1106.02(k), and 1106.02(l) to read:

“(g) Truck Mounted/Trailer Mounted Attenuators. The attenuator shall be approved for use at Test Level 3. Test Level 2 may be used for normal posted speeds less than or equal to 45 mph.

(k) Temporary Water Filled Barrier. The water filled barrier shall be a lightweight plastic shell designed to accept water ballast and be on the Department’s qualified product list.

Shop drawings shall be furnished by the manufacturer and shall indicate the deflection of the barrier as determined by acceptance testing; the configuration of the barrier in that test; and the vehicle weight, velocity, and angle of impact of the deflection test. The Engineer shall be provided one copy of the shop drawings.

(l) Movable Traffic Barrier. The movable traffic barrier shall be on the Department’s qualified product list.

Shop drawings shall be furnished by the manufacturer and shall indicate the deflection of the barrier as determined by acceptance testing; the configuration of the barrier in that test; and the vehicle weight, velocity, and angle of impact of the deflection test. The Engineer shall be provided one copy of the shop drawings. The barrier shall be capable of being moved on and off the roadway on a daily basis.”

State of Illinois
Department of Transportation
Bureau of Local Roads and Streets

SPECIAL PROVISION
FOR
INSURANCE

Effective: February 1, 2007
Revised: August 1, 2007

All references to Sections or Articles in this specification shall be construed to mean specific Section or Article of the Standard Specifications for Road and Bridge Construction, adopted by the Department of Transportation.

The Contractor shall name the following entities as additional insured under the Contractor's general liability insurance policy in accordance with Article 107.27:

The entities listed above and their officers, employees, and agents shall be indemnified and held harmless in accordance with Article 107.26.

State of Illinois
DEPARTMENT OF TRANSPORTATION
Bureau of Local Roads & Streets
SPECIAL PROVISION
FOR
LOCAL QUALITY ASSURANCE/ QUALITY MANAGEMENT QC/QA
Effective: January 1, 2022

Replace the first five paragraphs of Article 1030.06 of the Standard Specifications with the following:

“1030.06 Quality Management Program. The Quality Management Program (QMP) will be Quality Control / Quality Assurance (QC/QA) according to the following.”

Delete Article 1030.06(d)(1) of the Standard Specifications.

Revise Article 1030.09(g)(3) of the Standard Specifications to read:

“(3) If core testing is the density verification method, the Contractor shall provide personnel and equipment to collect density verification cores for the Engineer. Core locations will be determined by the Engineer following the document “Hot-Mix Asphalt QC/QA Procedure for Determining Random Density Locations” at density verification intervals defined in Article 1030.09(b). After the Engineer identifies a density verification location and prior to opening to traffic, the Contractor shall cut a 4 in. (100 mm) diameter core. With the approval of the Engineer, the cores may be cut at a later time.”

Revise Article 1030.09(h)(2) of the Standard Specifications to read:

“(2) After final rolling and prior to paving subsequent lifts, the Engineer will identify the random density verification test locations. Cores or nuclear density gauge testing will be used for density verification. The method used for density verification will be as selected below.

Density Verification Method	
<input type="checkbox"/>	Cores
<input checked="" type="checkbox"/>	Nuclear Density Gauge (Correlated when paving \geq 3,000 tons per mixture)

Density verification test locations will be determined according to the document “Hot-Mix Asphalt QC/QA Procedure for Determining Random Density Locations”. The density testing interval for paving wider than or equal to 3 ft (1 m) will be 0.5 miles (800 m) for lift thicknesses of 3 in. (75 mm) or less and 0.2 miles (320 m) for lift thicknesses greater than 3 in. (75 mm). The density testing interval for paving less than 3 ft (1 m) wide will be 1 mile (1,600 m). If a day’s paving will be less than the prescribed density testing interval, the length of the day’s paving will be the interval for that day. The density testing interval for mixtures used for patching will be 50 patches with a minimum of one test per mixture per project.

If core testing is the density verification method, the Engineer will witness the Contractor coring, and secure and take possession of all density samples at the

density verification locations. The Engineer will test the cores collected by the Contractor for density according to Illinois Modified AASHTO T 166 or AASHTO T 275.

If nuclear density gauge testing is the density verification method, the Engineer will conduct nuclear density gauge tests. The Engineer will follow the density testing procedure detailed in the document "Illinois Modified ASTM D 2950, Standard Test Method for Density of Bituminous Concrete In-Place by Nuclear Method".

A density verification test will be the result of a single core or the average of the nuclear density tests at one location. The results of each density test must be within acceptable limits. The Engineer will promptly notify the Contractor of observed deficiencies."

Revise the seventh paragraph and all subsequent paragraphs in Section D. of the document "Hot-Mix Asphalt QC/QA Initial Daily Plant and Random Samples" to read:

"Mixtures shall be sampled from the truck at the plant by the Contractor following the same procedure used to collect QC mixture samples (Section A). This process will be witnessed by the Engineer who will take custody of the verification sample. Each sample bag with a verification mixture sample will be secured by the Engineer using a locking ID tag. Sample boxes containing the verification mixture sample will be sealed/taped by the Engineer using a security ID label."

ABV	ABOVE	CU YD	CUBIC YARD	HATCH	HATCHING	PM	PAVEMENT MARKING	STD	STANDARD
A/C	ACCESS CONTROL	CULV	CULVERT	HD	HEAD	PED	PEDESTAL	SBI	STATE BOND ISSUE
AC	ACRE	C&G	CURB & GUTTER	HDW	HEADWALL	PNT	POINT	SR	STATE ROUTE
ADJ	ADJUST	D	DEGREE OF CURVE	HDUTY	HEAVY DUTY	PC	POINT OF CURVATURE	STA	STATION
AS	AERIAL SURVEYS	DC	DEPRESSED CURVE	ha	HECTARE	PI	POINT OF INTERSECTION OF HORIZONTAL CURVE	SPBGR	STEEL PLATE BEAM GUARDRAIL
AGG	AGGREGATE	DET	DETECTOR	HMA	HOT MIX ASPHALT			SS	STORM SEWER
AH	AHEAD	DIA	DIAMETER	HWY	HIGHWAY	PRC	POINT OF REVERSE CURVE	STY	STORY
APT	APARTMENT	DIST	DISTRICT	HORIZ	HORIZONTAL	PT	POINT OF TANGENCY	ST	STREET
ASPH	ASPHALT	DOM	DOMESTIC	HSE	HOUSE	POT	POINT ON TANGENT	STR	STRUCTURE
AUX	AUXILIARY	DBL	DOUBLE	IL	ILLINOIS	POLYETH	POLYETHYLENE	e	SUPERELEVATION RATE
AGS	AUXILIARY GAS VALVE (SERVICE)	DSEL	DOWNSTREAM ELEVATION	IMP	IMPROVEMENT	PCC	PORTLAND CEMENT CONCRETE	S.E. RUN.	SUPERELEVATION RUNOFF LENGTH
AVE	AVENUE	DSFL	DOWNSTREAM FLOWLINE	IN DIA	INCH DIAMETER	PP	POWER POLE OR PRINCIPAL POINT	SURF	SURFACE
AX	AXIS OF ROTATION	DR	DRAINAGE OR DRIVE	INL	INLET	PRM	PRIME	SMK	SURVEY MARKER
BK	BACK	DI	DRAINAGE INLET OR DROP INLET	INST	INSTALLATION	PE	PRIVATE ENTRANCE	T	TANGENT DISTANCE
B-B	BACK TO BACK	DRV	DRIVEWAY	IDS	INTERSECTION DESIGN STUDY	PROF	PROFILE	T.R.	TANGENT RUNOUT DISTANCE
BKPL	BACKPLATE	DCT	DUCT	INV	INVERT	PGL	PROFILE GRADELINE	TEL	TELEPHONE
B	BARN	EA	EACH	IP	IRON PIPE	PROJ	PROJECT	TB	TELEPHONE BOX
BARR	BARRICADE	EB	EASTBOUND	IR	IRON ROD	P.C.	PROPERTY CORNER	TP	TELEPHONE POLE
BL	BASELINE	EOP	EDGE OF PAVEMENT	JT	JOINT	PL	PROPERTY LINE	TEMP	TEMPORARY
BGN	BEGIN	E-CL	EDGE TO CENTERLINE	kg	KILOGRAM	PR	PROPOSED	TBM	TEMPORARY BENCH MARK
BM	BENCHMARK	E-E	EDGE TO EDGE	km	KILOMETER	R	RADIUS or RESIDENTUAL	TD	TILE DRAIN
BIND	BINDER	ELEC	ELECTRICAL	LS	LANDSCAPING	RR	RAILROAD	TBE	TO BE EXTENDED
BIT	BITUMINOUS	EL	ELEVATION	LN	LANE	RRS	RAILROAD SPIKE	TBR	TO BE REMOVED
BTM	BOTTOM	ENTR	ENTRANCE	LT	LEFT	RPS	REFERENCE POINT STAKE	TBS	TO BE SAVED
BLVD	BOULEVARD	EXC	EXCAVATION	LIDAR	LIGHT DETECTION AND RANGING	REF	REFLECTIVE	TWP	TOWNSHIP
BRK	BRICK	EX	EXISTING	LP	LIGHT POLE	RCCP	REINFORCED CONCRETE CULVERT PIPE	TR	TOWNSHIP ROAD
BBOX	BUFFALO BOX	EXPWAY	EXPRESSWAY	LGT	LIGHTING	REINF	REINFORCEMENT	TS	TRAFFIC SIGNAL
BLDG	BUILDING	E	EXTERNAL DISTANCE OF HORIZONTAL CURVE	LF	LINEAL FEET OR LINEAR FEET	REM	REMOVAL	TSCB	TRAFFIC SIGNAL CONTROL BOX
CATV	CABLE	E	OFFSET DISTANCE TO VERTICAL CURVE	L	LITER OR CURVE LENGTH	RC	REMOVE CROWN	TSC	TRAFFIC SYSTEMS CENTER
CIP	CAST IRON PIPE	F-F	FACE TO FACE	LC	LONG CHORD	REP	REPLACEMENT	TRVS	TRANSVERSE
CB	CATCH BASIN	FA	FEDERAL AID	LNG	LONGITUDINAL	REST	RESTAURANT	TRVL	TRAVEL
C-C	CENTER TO CENTER	FAI	FEDERAL AID INTERSTATE	L SUM	LUMP SUM	RESURF	RESURFACING	TRN	TURN
CL	CENTERLINE OR CLEARANCE	FAP	FEDERAL AID PRIMARY	MACH	MACHINE	RET	RETAINING	TY	TYPE
CL-E	CENTERLINE TO EDGE	FAS	FEDERAL AID SECONDARY	MB	MAIL BOX	RT	RIGHT	T-A	TYPE A
CL-F	CENTERLINE TO FACE	FAUS	FEDERAL AID URBAN SECONDARY	MH	MANHOLE	ROW	RIGHT-OF-WAY	TYP	TYPICAL
CTS	CENTERS	FP	FENCE POST	MATL	MATERIAL	RD	ROAD	UNDGND	UNDERGROUND
CERT	CERTIFIED	OPT	FIBER OPTIC	MED	MEDIAN	RDWY	ROADWAY	USGS	U.S. GEOLOGICAL SURVEY
CHSLD	CHISELED	FE	FIELD ENTRANCE	m	METER	RTE	ROUTE	USEL	UPSTREAM ELEVATION
CS	CITY STREET	FH	FIRE HYDRANT	METH	METHOD	SAN	SANITARY	USFL	UPSTREAM FLOWLINE
CP	CLAY PIPE	FL	FLOW LINE	M	MID-ORDINATE	SANS	SANITARY SEWER	UTIL	UTILITY
CLSD	CLOSED	FB	FOOT BRIDGE	mm	MILLIMETER	SEC	SECTION	VBOX	VALVE BOX
CLID	CLOSED LID	FDN	FOUNDATION	mm DIA	MILLIMETER DIAMETER	SEED	SEEDING	VV	VALVE VAULT
CT	COAT OR COURT	FR	FRAME	MIX	MIXTURE	SHAP	SHAPING	VLT	VAULT
COMB	COMBINATION	F&G	FRAME & GRATE	MBH	MOBILE HOME	S	SHED	VEH	VEHICLE
C	COMMERCIAL BUILDING	FRWAY	FREEWAY	MOD	MODIFIED	SH	SHEET	VP	VENT PIPE
CE	COMMERCIAL ENTRANCE	GAL	GALLON	MFT	MOTOR FUEL TAX	SHLD	SHOULDER	VERT	VERTICAL
CONC	CONCRETE	GALV	GALVANIZED	N & BC	NAIL & BOTTLE CAP	SW	SIDEWALK OR SOUTHWEST	VC	VERTICAL CURVE
CONST	CONSTRUCT	G	GARAGE	N & C	NAIL & CAP	SIG	SIGNAL	VPC	VERTICAL POINT OF CURVATURE
CONTD	CONTINUED	GM	GAS METER	N & W	NAIL & WASHER	SOD	SODDING	VPI	VERTICAL POINT OF INTERSECTION
CONT	CONTINUOUS	GV	GAS VALVE	NC	NORMAL CROWN	SM	SOLID MEDIATE	VPT	VERTICAL POINT OF TANGENCY
COR	CORNER	GIS	GEOGRAPHICAL INFORMATION SYSTEM	NB	NORTHBOUND	SB	SOUTHBOUND	WM	WATER METER
CORR	CORRUGATED	GRAN	GRANULAR	NE	NORTHEAST	SE	SOUTHEAST	WV	WATER VALVE
CMP	CORRUGATED METAL PIPE	GR	GRATE	NW	NORTHWEST	SPL	SPECIAL	WMAIN	WATER MAIN
CNTY	COUNTY	GRVL	GRAVEL	O/S	OFFSET	SD	SPECIAL DITCH	WB	WESTBOUND
CH	COUNTY HIGHWAY	GND	GROUND	O&C	OIL AND CHIP	SQ FT	SQUARE FEET	WILDFL	WILDFLOWERS
CSE	COURSE	GUT	GUTTER	OLID	OPEN LID	m ²	SQUARE METER	W	WITH
XSECT	CROSS SECTION	GP	GUY POLE	PAT	PATTERN	mm ²	SQUARE MILLIMETER	WO	WITHOUT
m ³	CUBIC METER	GW	GUY WIRE	PVD	PAVED	SQ YD	SQUARE YARD		
mm ³	CUBIC MILLIMETER	HH	HANDHOLE	PVMT	PAVEMENT	STB	STABILIZED		

Illinois Department of Transportation

RECEIVED January 1, 2021

APPROVED January 1, 2021

ENGINEER OF POLICY AND PROCEDURES

ENGINEER OF DESIGN AND ENVIRONMENT

ISSUED 1-1-97

DATE	REVISIONS
1-1-21	Updated fonts, abbreviations, and symbols.
1-1-19	Added new symbols.

**STANDARD SYMBOLS,
ABBREVIATIONS,
AND PATTERNS**

(Sheet 1 of 9)

STANDARD 000001-08

EROSION & SEDIMENT CONTROL ITEMS

EX

PR

- Cleaning & Grading Limits
- Dike
- Erosion Control Fence
- Perimeter Erosion Barrier
- Temporary Fence
- Ditch Check Temporary
- Ditch Check Permanent
- Inlet & Pipe Protection
- Sediment Basin
- Erosion Control Blanket
- Fabric Formed Concrete Revetment Mat
- Turf Reinforcement Mat
- Mulch Temporary
- Mulch Method 1
- Mulch Method 2 Stabilized
- Mulch Method 3 Hydraulic

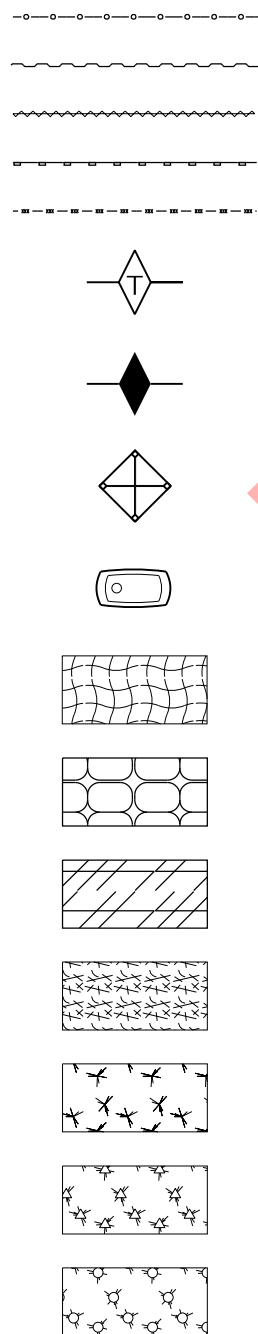

CONTOUR ITEMS

EX

PR

- Approx. Index Line
- Approx. Intermediate Line
- Index Contour
- Intermediate Contour

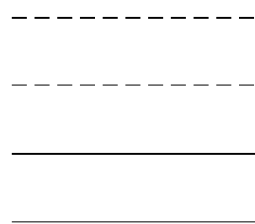

NON-HIGHWAY IMPROVEMENT ITEMS

EX

PR

- Noise Attn./Levee
- Field Line
- Fence
- Base of Levee
- Mailbox
- Multiple Mailboxes
- Pay Telephone
- Advertising Sign
- *ITS Camera
- Wind Turbine
- Cellular Tower
- *Intelligent Transportation Systems

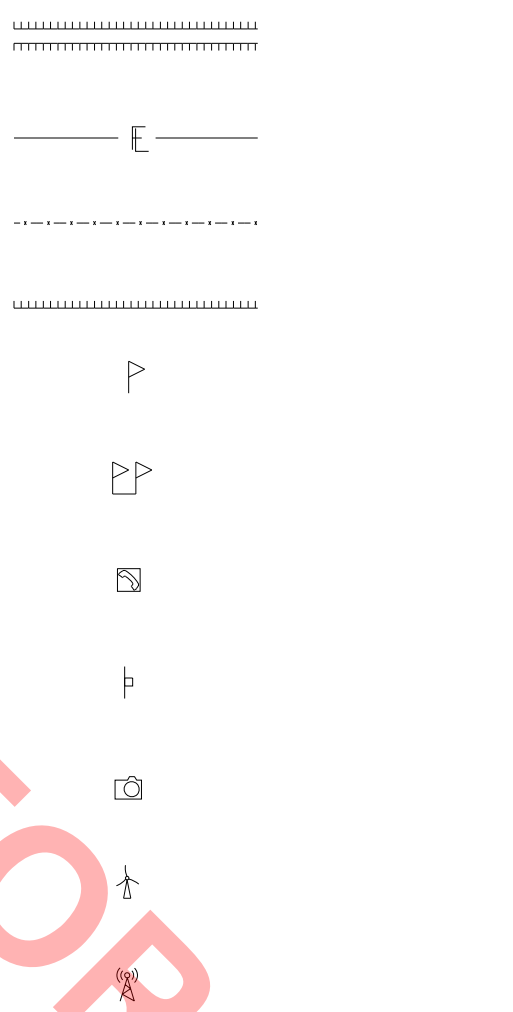

LANDSCAPING ITEMS

EX

PR

- Contour Mounding Line
- Fence
- Fence Post
- Shrubs
- Mowline
- Perennial Plants
- Seeding Class 2
- Seeding Class 2A
- Seeding Class 4
- Seeding Class 4 & 5 Combined

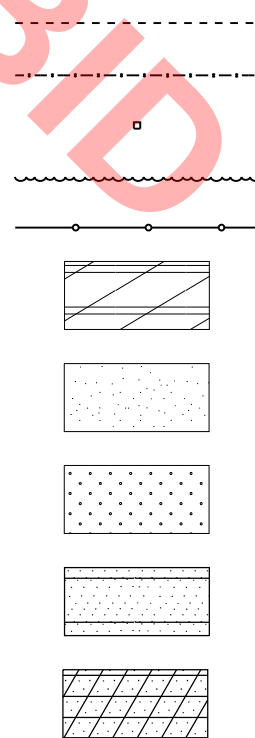

EXISTING LANDSCAPING ITEMS (contd.)

EX

PR

- Seeding Class 5
- Seeding Class 7
- Seedlings Type 1
- Seedlings Type 2
- Sodding
- Mowstake w/Sign
- Tree Trunk Protection
- Evergreen Tree
- Shade Tree

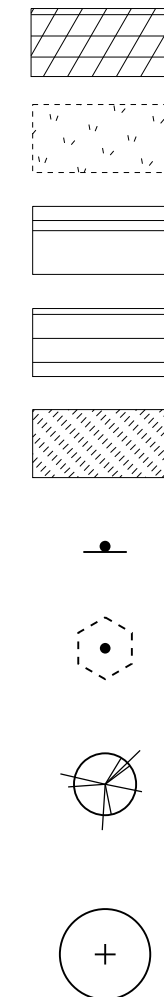

LIGHTING

EX

PR

- Duct
- Conduit
- Electrical Aerial Cable
- Electrical Buried Cable
- Controller
- Underpass Luminaire
- Power Pole

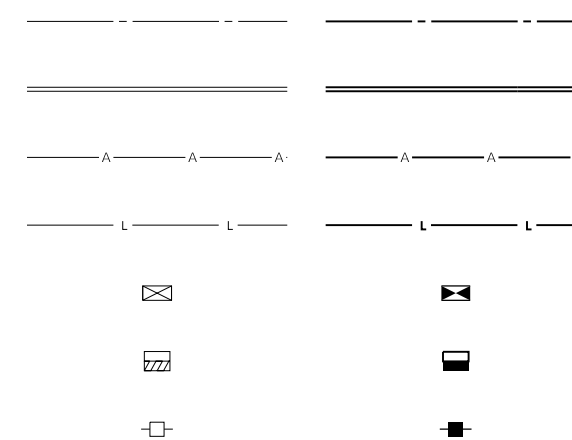

STANDARD SYMBOLS, ABBREVIATIONS, AND PATTERNS

(Sheet 3 of 9)

STANDARD 000001-08

Illinois Department of Transportation

APPROVED January 1, 2021

 ENGINEER OF POLICY AND PROCEDURES

APPROVED January 1, 2021

 ENGINEER OF DESIGN AND ENVIRONMENT

ISSUED 1-1-97

**LIGHTING
(contd.)**

EX

PR

Pull Point



Handhole



Heavy Duty Handhole



Junction Box



Light Unit Comb.



Electrical Ground



Traffic Flow Arrow



High Mast Pole
(Half Size)



Light Unit-1

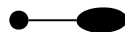

PAVEMENT (MISC.)

EX

PR

Keyed Long. Joint

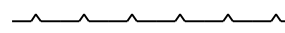

Keyed Long. Joint w/Tie Bars

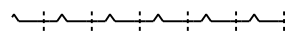

Sawed Long. Joint w/Tie Bars

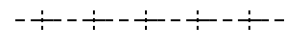

Bituminous Shoulder



Bituminous Taper



Stabilized Driveway



Widening



PAVEMENT MARKINGS

EX

PR

Handicap Symbol



RR Crossing

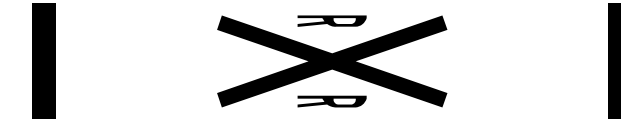
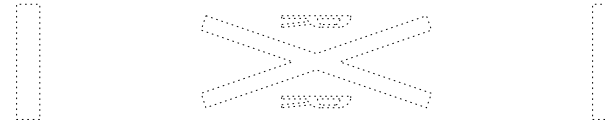

Raised Marker Amber 1 Way



Raised Marker Amber 2 Way



Raised Marker Crystal 1 Way



Two Way Turn Left

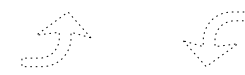

Shoulder Diag. Pattern

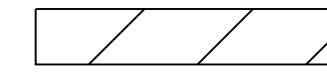
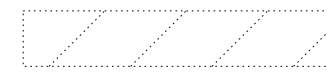

Skip-Dash White



Skip-Dash Yellow



Stop Line

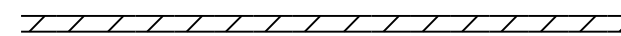
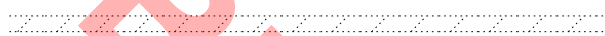

Solid Line

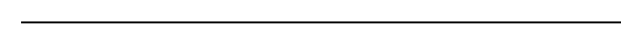
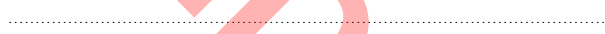

Double Centerline

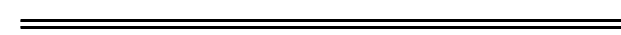

Dotted Lines



Illinois Department of Transportation

APPROVED January 1, 2021

 ENGINEER OF POLICY AND PROCEDURES

APPROVED January 1, 2021

 ENGINEER OF DESIGN AND ENVIRONMENT

ISSUED 1-1-97

**STANDARD SYMBOLS,
ABBREVIATIONS,
AND PATTERNS** (Sheet 4 of 9)

STANDARD 000001-08

PAVEMENT MARKINGS
(contd.)

CL 2Ln 2Way
RRPM 12.2 m (40') o.c.

CL 2Ln 2Way
RRPM 80' (24.4 m) o.c.

CL Multilane Div.
RRPM 40' (12.2 m) o.c.

CL Multilane Div.
RRPM 80' (24.4 m) o.c.

CL Multilane Div. Dbl.
RRPM 80' (24.4 m) o.c.

CL Multilane Undiv.

Two Way Turn Left Line

Urban Combination Left

Urban Combination Right

Urban Left Turn Arrow

Urban Right Turn Arrow

Urban Left Turn Only

Urban Right Turn Only

Urban Thru Only

EX

PR

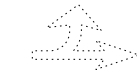
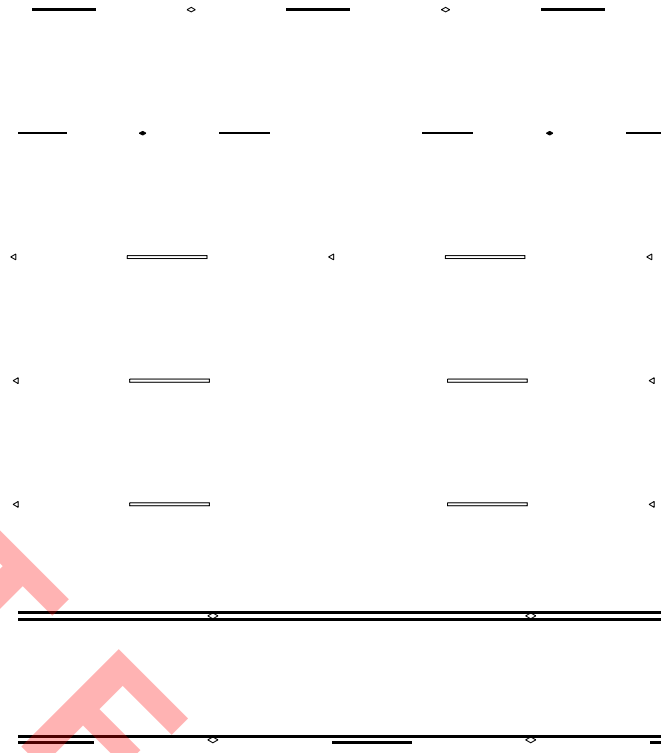

ONLY
ONLY
ONLY

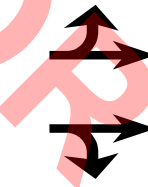

RAILROAD ITEMS

EX

PR

Abandoned Railroad

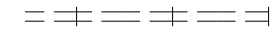

Railroad



Railroad Point



Control Box



Crossing Gate



Flashing Signal



Railroad Cant. Mast Arm

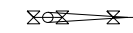

Crossbuck



REMOVAL ITEMS

EX

PR

Removal Tic

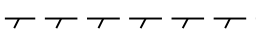

Bituminous Removal

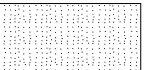

Hatch Pattern



Tree Removal Single



RIGHT OF WAY ITEMS

EX

PR

Future ROW Corner Monument



ROW Marker



ROW Line



Easement



Temporary Easement

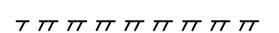

**STANDARD SYMBOLS,
ABBREVIATIONS,
AND PATTERNS**

(Sheet 5 of 9)

STANDARD 000001-08

Illinois Department of Transportation

APPROVED January 1, 2021

ENGINEER OF POLICY AND PROCEDURES

APPROVED January 1, 2021

ENGINEER OF DESIGN AND ENVIRONMENT

ISSUED 1-1-97

Urban LT & RT Turn Arrow

Urban Thru Arrow

PAVEMENT MARKINGS
(contd.)

EX

PR

Urban U-Turn

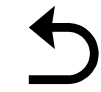

Urban Combined U-Turn

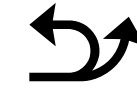

Rural Combination Left



Rural Combination Right



Rural Left Turn Arrow



Rural Right Turn Arrow



Rural Left Turn Only

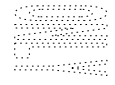

Rural Right Turn Only

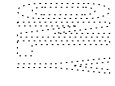

Rural Thru Only

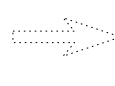
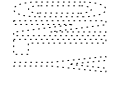

Rural Thru Arrow



Rural Lt & Rt Turn Arrow



Bike Lane Symbol



Bike Lane Text



Bike Path Shared

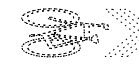

Bike Shared Roadway



Lane Drop Symbol

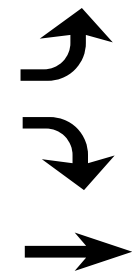

Illinois Department of Transportation
 APPROVED January 1, 2021

 ENGINEER OF POLICY AND PROCEDURES
 APPROVED January 1, 2021

 ENGINEER OF DESIGN AND ENVIRONMENT

Wrong Way Arrow

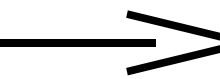
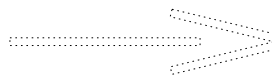

NOT FOR BIDDING
 ONLY ONLY ONLY

**STANDARD SYMBOLS,
ABBREVIATIONS,
AND PATTERNS**

(Sheet 6 of 9)

STANDARD 000001-08

**RIGHT OF WAY ITEMS
(contd.)**

	EX	PR
Access Control Line		
Access Control Line & ROW		
Access Control Line & ROW with Fence		
Excess ROW Line		

**ROADWAY PLAN
ITEMS**

	EX	PR
Cable Barrier		
Concrete Barrier		
Edge of Pavement		
Bit Shoulders, Medians and C&G Line		
Aggregate Shoulder		
Sidewalks, Driveways		
Guardrail		
Guardrail Post		
Traffic Sign		
Corrugated Median		
Impact Attenuator		
North Arrow with District Office (Half Size)		
Match Line		
Slope Limit Line		
Typical Cross-Section Line		

ROADWAY PROFILES

	EX	PR
P.I. Indicator		
Point Indicator		
Earthworks Balance Point		
Begin Point		
Vert. Curve Data	VPI = ELEV = L = E =	VPI = ELEV = L = E =
Ditch Profile Left Side		
Ditch Profile Right Side		
Roadway Profile Line		
Storm Sewer Profile Left Side		
Storm Sewer Profile Right Side		

SIGNING ITEMS

	EX	PR
Cone, Drum or Barricade		
Barricade Type II		
Barricade Type III		
Barricade With Edge Line		
Flashing Light Sign		
Panels I		
Panels II		
Direction of Traffic		
Sign Flag (Half Size)		

**SIGNING ITEMS
(contd.)**

	EX	PR
Reverse Left W1-4L (Half Size)		
Reverse Right W1-4R (Half Size)		
Two Way Traffic Sign W6-3 (Half Size)		
Detour Ahead W20-2(O) (Half Size)		
Left Lane Closed Ahead W20-5L(O) (Half Size)		
Right Lane Closed Ahead W20-5R(O) (Half Size)		
Road Closed Ahead W20-3(O) (Half Size)		
Road Construction Ahead W20-1(O) (Half Size)		
Single Lane Ahead (Half Size)		
Transition Left W4-2L (Half Size)		
Transition Right W4-2R (Half Size)		

Illinois Department of Transportation

APPROVED January 1, 2021
[Signature]
ENGINEER OF POLICY AND PROCEDURES

APPROVED January 1, 2021
[Signature]
ENGINEER OF DESIGN AND ENVIRONMENT

ISSUED 1-1-97

**STANDARD SYMBOLS,
ABBREVIATIONS,
AND PATTERNS** (Sheet 7 of 9)

STANDARD 000001-08

SIGNING ITEMS
(contd.)

EX

PR

- One Way Arrow Lrg. W1-6-(O)
(Half Size)
- Two Way Arrow Large W1-7-(O)
(Half Size)
- Detour M4-10L-(O)
(Half Size)
- Detour M4-10R-(O)
(Half Size)
- One Way Left R6-1L
(Half Size)
- One Way Right R6-1R
(Half Size)
- Left Turn Lane R3-I100L
(Half Size)
- Keep Left R4-7AL
(Half Size)
- Keep Left R4-7BL
(Half Size)
- Keep Right R4-7AR
(Half Size)
- Keep Right R4-7BR
(Half Size)
- Stop Here On Red R10-6-AL
(Half Size)
- Stop Here On Red R10-6-AR
(Half Size)
- No Left Turn R3-2
(Half Size)
- No Right Turn R3-1
(Half Size)
- Road Closed R11-2
(Half Size)
- Road Closed Thru Traffic R11-2
(Half Size)

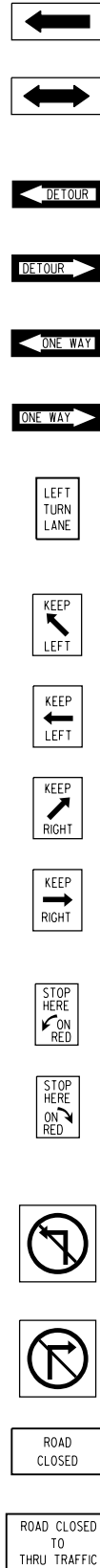

STRUCTURES ITEMS

EX

PR

- Box Culvert Barrel
- Box Culvert Headwall
- Bridge Pier
- Bridge
- Retaining Wall
- Temporary Sheet Piling

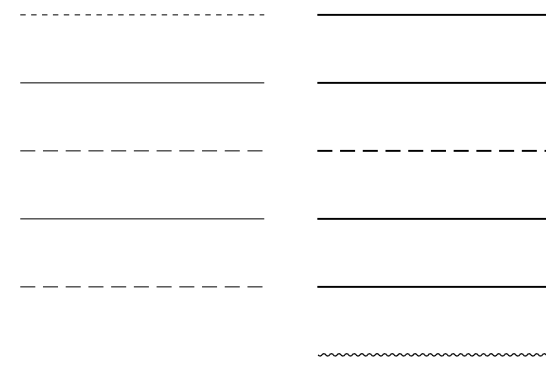

TRAFFIC SHEET ITEMS

EX

PR

- Cable Number
- Left Turn Green
- Left Turn Yellow
- Signal Backplate
- Signal Section 8" (200 mm)
- Signal Section 12" (300 mm)
- Walk/Don't Walk Letters
- Walk/Don't Walk Symbols

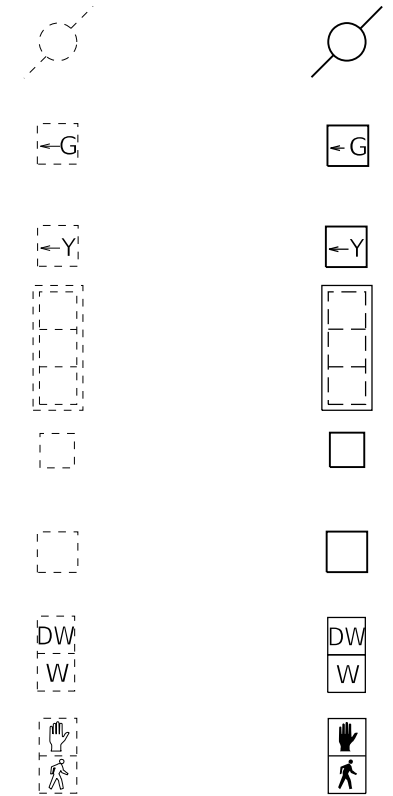

TRAFFIC SIGNAL ITEMS

EX

PR

- Galv. Steel Conduit
- Underground Cable
- Detector Loop Line
- Detector Loop Large
- Detector Loop Small
- Detector Loop Quadrapole

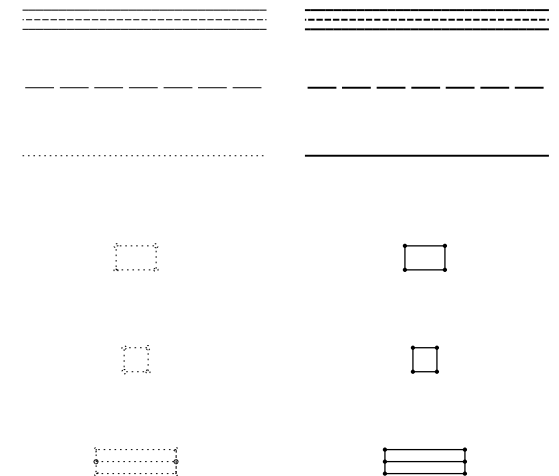

**STANDARD SYMBOLS,
ABBREVIATIONS,
AND PATTERNS**

(Sheet 8 of 9)

STANDARD 000001-08

Illinois Department of Transportation

APPROVED January 1, 2021
Michael Bond
ENGINEER OF POLICY AND PROCEDURES

APPROVED January 1, 2021
Scott E. [Signature]
ENGINEER OF DESIGN AND ENVIRONMENT

ISSUED 1-1-97

NOT FOR BID

TRAFFIC SIGNAL ITEMS (contd.)

EX

PR

Detector Raceway



Aluminum Mast Arm



Steel Mast Arm



Veh. Detector Magnetic



Conduit Splice



Controller



Gulfbox Junction



Wood Pole



Temp. Signal Head



Handhole



Double Handhole



Heavy Duty Handhole



Junction Box



Ped. Pushbutton Detector



Ped. Signal Head



Power Pole Service



Priority Veh. Detector



Signal Head



Signal Head w/Backplate



Signal Post



Closed Circuit TV



Video Detector System



UNDERGROUND UTILITY ITEMS

EX

PR

ABANDONED

Cable TV

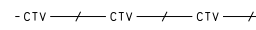
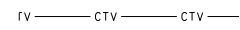

Electric Cable

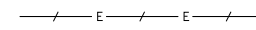
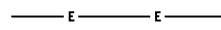
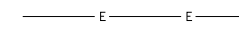

Fiber Optic

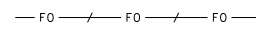
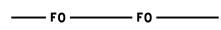
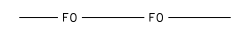

Gas Pipe

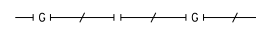
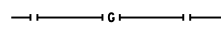
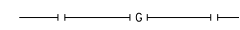

Oil Pipe

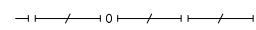
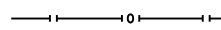
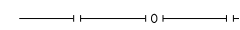

Sanitary Sewer

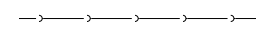
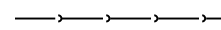
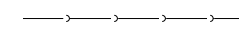

Telephone Cable

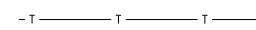
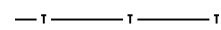
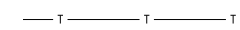

Water Pipe

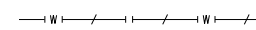
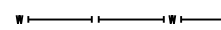
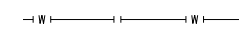

UTILITIES ITEMS

EX

PR

Controller



Double Handhole



Fire Hydrant



GuyWire or Deadman Anchor



Handhole



Heavy Duty Handhole



Junction Box



Light Pole



Manhole



Monitoring Well (Gasoline)



Pipeline Warning Sign



Power Pole



Power Pole with Light



Sanitary Sewer Cleanout



Splice Box Above Ground



Telephone Splice Box Above Ground



Telephone Pole



UTILITY ITEMS (contd.)

EX

PR

Traffic Signal



Traffic Signal Control Box



Water Meter



Water Meter Valve Box



Profile Line

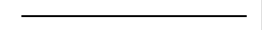

Aerial Power Line

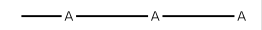

VEGETATION ITEMS

EX

PR

Deciduous Tree



Bush or Shrub



Evergreen Tree



Stump



Orchard/Nursery Line

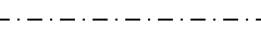

Vegetation Line



Woods & Bush Line

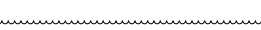

WATER FEATURE ITEMS

EX

PR

Stream or Drainage Ditch

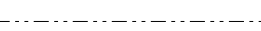

Waters Edge

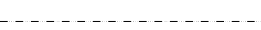

Water Surface Indicator



Water Point



Disappearing Ditch



Marsh



Marsh/Swamp Boundary

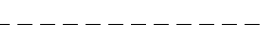

STANDARD SYMBOLS, ABBREVIATIONS, AND PATTERNS

(Sheet 9 of 9)

STANDARD 000001-08

Illinois Department of Transportation

APPROVED January 1, 2021

ENGINEER OF POLICY AND PROCEDURES

APPROVED January 1, 2021

ENGINEER OF DESIGN AND ENVIRONMENT

ISSUED 1-1-97

DECIMAL OF AN INCH AND OF A FOOT

A		B		A		B		A		B		A		B			
1/64	0.0052	1/16	11/64	0.171875	2 1/16	11/32	0.3385	4 1/16	33/64	0.5052	6 1/16	43/64	0.671875	8 1/16	27/32	0.8385	10 1/16
	0.0104	1/8		0.1771	2 1/8		0.34375	4 1/8		0.5104	6 1/8		0.6771	8 1/8		0.84375	10 1/8
	0.015625	3/16		0.1823	2 3/16		0.3490	4 3/16		0.515625	6 3/16		0.6823	8 3/16		0.8490	10 3/16
	0.0208	1/4		0.1875	2 1/4		0.3542	4 1/4		0.5208	6 1/4		0.6875	8 1/4		0.8542	10 1/4
1/32	0.0260	5/16	13/64	0.1927	2 5/16	23/64	0.359375	4 5/16	17/32	0.5260	6 5/16	45/64	0.6927	8 5/16	55/64	0.859375	10 5/16
	0.03125	3/8		0.1979	2 3/8		0.3646	4 3/8		0.53125	6 3/8		0.6979	8 3/8		0.8646	10 3/8
	0.0365	7/16		0.203125	2 7/16		0.3698	4 7/16		0.5365	6 7/16		0.703125	8 7/16		0.8698	10 7/16
	0.0417	1/2		0.2083	2 1/2		0.3750	4 1/2		0.5417	6 1/2		0.7083	8 1/2		0.8750	10 1/2
3/64	0.046875	9/16	7/32	0.2135	2 9/16	25/64	0.3802	4 9/16	35/64	0.546875	6 9/16	23/32	0.7135	8 9/16	57/64	0.8802	10 9/16
	0.0521	5/8		0.21875	2 5/8		0.3854	4 5/8		0.5521	6 5/8		0.71875	8 5/8		0.8854	10 5/8
	0.0573	1 1/16		0.2240	2 1 1/16		0.390625	4 1 1/16		0.5573	6 1 1/16		0.7240	8 1 1/16		0.890625	10 1 1/16
	0.0625	3/4		0.2292	2 3/4		0.3958	4 3/4		0.5625	6 3/4		0.7292	8 3/4		0.8958	10 3/4
1/16	0.0677	13/16	15/64	0.234375	2 13/16	13/32	0.4010	4 13/16	9/16	0.5677	6 13/16	47/64	0.734375	8 13/16	29/32	0.9010	10 13/16
	0.0729	7/8		0.2396	2 7/8		0.40625	4 7/8		0.5729	6 7/8		0.7396	8 7/8		0.90625	10 7/8
	0.078125	15/16		0.2448	2 15/16		0.4115	4 15/16		0.578125	6 15/16		0.7448	8 15/16		0.9115	10 15/16
	0.0833	1		0.2500	3		0.4167	5		0.5833	7		0.7500	9		0.9167	11
3/32	0.0885	1 1/16	17/64	0.2552	3 1/16	27/64	0.421875	5 1/16	19/32	0.5885	7 1/16	49/64	0.7552	9 1/16	59/64	0.921875	11 1/16
	0.09375	1 1/8		0.2604	3 1/8		0.4271	5 1/8		0.59375	7 1/8		0.7604	9 1/8		0.9271	11 1/8
	0.0990	1 3/16		0.265625	3 3/16		0.4323	5 3/16		0.5990	7 3/16		0.765625	9 3/16		0.9323	11 3/16
	0.1042	1 1/4		0.2708	3 1/4		0.4375	5 1/4		0.6042	7 1/4		0.7708	9 1/4		0.9375	11 1/4
7/64	0.109375	1 5/16	9/32	0.2760	3 5/16	29/64	0.4427	5 5/16	39/64	0.609375	7 5/16	25/32	0.7760	9 5/16	61/64	0.9427	11 5/16
	0.1146	1 3/8		0.28125	3 3/8		0.4479	5 3/8		0.6146	7 3/8		0.78125	9 3/8		0.9479	11 3/8
	0.1198	1 7/16		0.2865	3 7/16		0.453125	5 7/16		0.6198	7 7/16		0.7865	9 7/16		0.953125	11 7/16
	0.1250	1 1/2		0.2917	3 1/2		0.4583	5 1/2		0.6250	7 1/2		0.7917	9 1/2		0.9583	11 1/2
1/8	0.1302	1 9/16	19/64	0.296875	3 9/16	15/32	0.4635	5 9/16	5/8	0.6302	7 9/16	51/64	0.796875	9 9/16	31/32	0.9635	11 9/16
	0.1354	1 5/8		0.3021	3 5/8		0.46875	5 5/8		0.6354	7 5/8		0.8021	9 5/8		0.96875	11 5/8
	0.140625	1 11/16		0.3073	3 11/16		0.4740	5 11/16		0.640625	7 11/16		0.8073	9 11/16		0.9740	11 11/16
	0.1458	1 3/4		0.3125	3 3/4		0.4792	5 3/4		0.6458	7 3/4		0.8125	9 3/4		0.9792	11 3/4
9/64	0.1510	1 13/16	5/16	0.3177	3 13/16	31/64	0.484375	5 13/16	41/64	0.6510	7 13/16	13/16	0.8177	9 13/16	63/64	0.984375	11 13/16
	0.15625	1 7/8		0.3229	3 7/8		0.4896	5 7/8		0.65625	7 7/8		0.8229	9 7/8		0.9896	11 7/8
	0.1615	1 15/16		0.328125	3 15/16		0.4948	5 15/16		0.6615	7 15/16		0.828125	9 15/16		0.9948	11 15/16
	0.1667	2		0.3333	4		0.5000	6		0.6667	8		0.8333	10		1.0000	12

A = Fractions of Inch or Foot

B = Inch Equivalents to Foot Fractions

Illinois Department of Transportation

APPROVED January 1, 1997
Garry Costey
 ENGINEER OF POLICY AND PROCEDURES

APPROVED January 1, 1997
Garry Gould
 ENGINEER OF DESIGN AND ENVIRONMENT

ISSUED 1-1-97

DATE	REVISIONS
1-1-97	New Standard.

**DECIMAL OF AN INCH
AND OF A FOOT**

STANDARD 001006

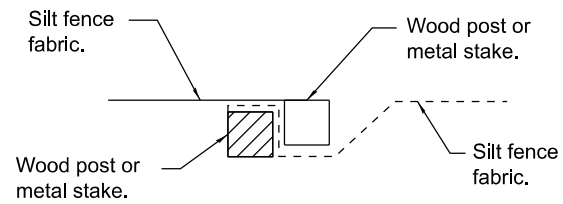

Place end-post (stake) of first silt fence adjacent to end-post (stake) of second silt fence with fabric positioned as shown.

STEP 1

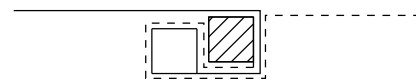

Rotate posts (stakes) together 180° clockwise and drive both posts (stakes) 18 (450) into ground.

STEP 2

ATTACHING TWO SILT FILTER FENCES

(Not applicable for J-hooks)

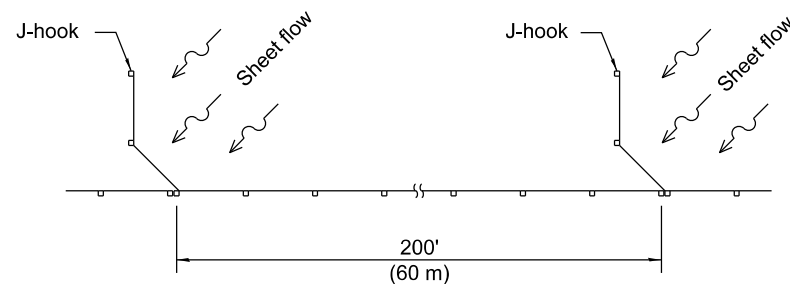

SILT FILTER J-HOOK PLACEMENT

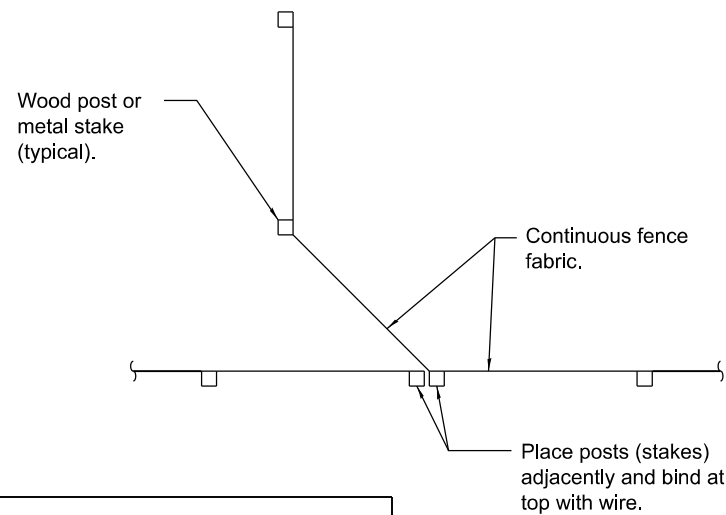

J-HOOK

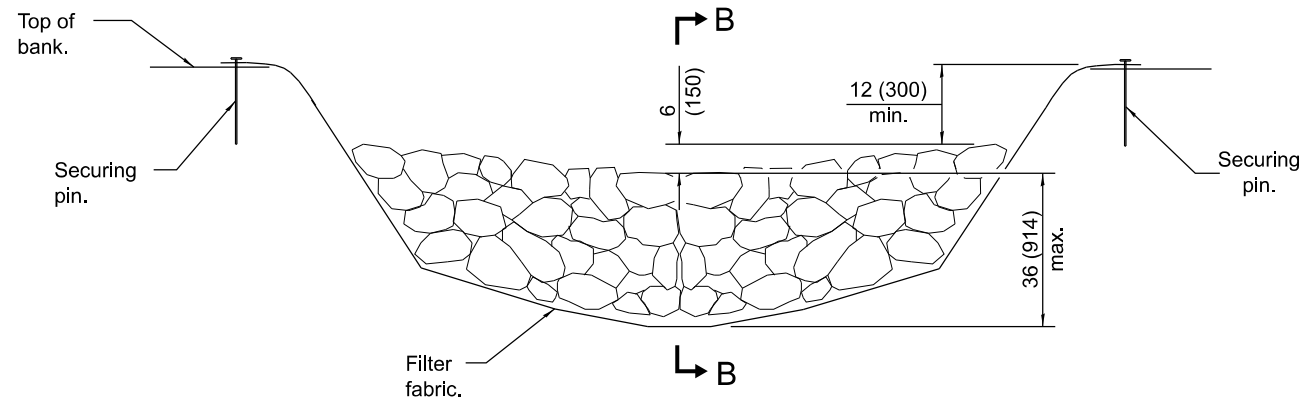

ELEVATION

* When the ditch check is within the clear zone and the road is open to traffic, the traffic approach slope of the aggregate shall be 1:4 (V:H).

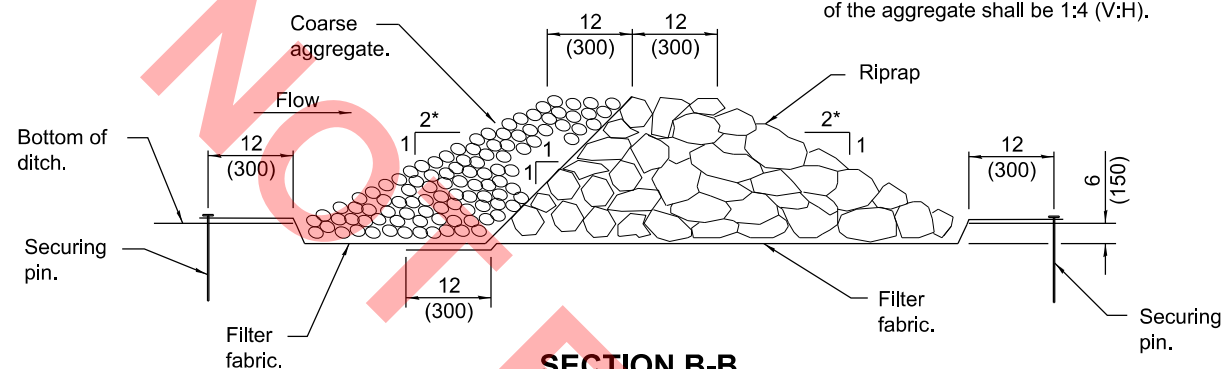

SECTION B-B

AGGREGATE DITCH CHECK

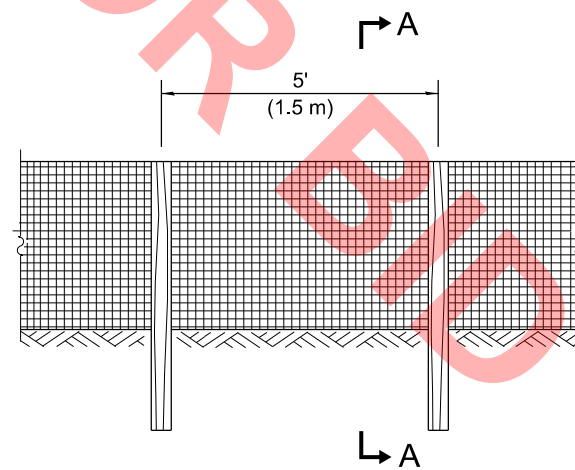

ELEVATION

SILT FILTER FENCE AS A PERIMETER EROSION BARRIER

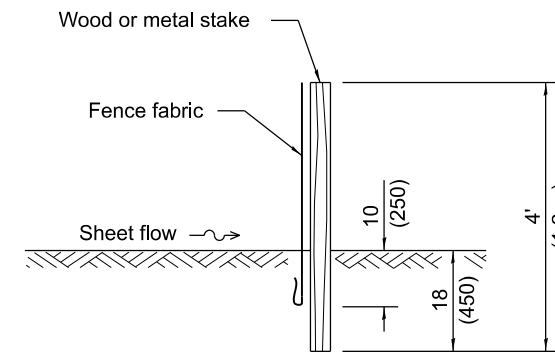

SLICE METHOD

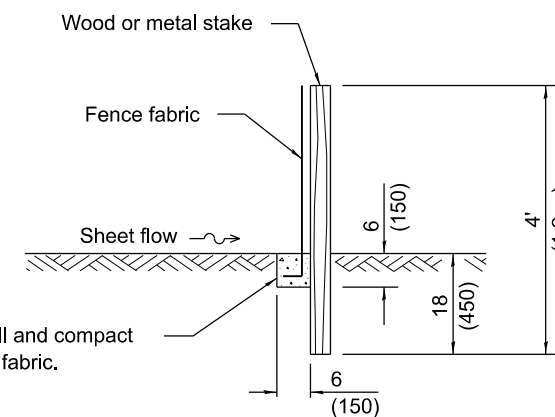

TRENCH METHOD

SECTION A-A

Excavate, backfill and compact trench to secure fabric.

GENERAL NOTES

The installation details and dimensions shown for perimeter erosion barriers shall also apply for inlet and pipe protection.

All dimensions are in inches (millimeters) unless otherwise shown.

Illinois Department of Transportation

APPROVED January 1, 2013
Michael Beard
 ENGINEER OF POLICY AND PROCEDURES

APPROVED January 1, 2013
[Signature]
 ENGINEER OF DESIGN AND ENVIRONMENT

ISSUED 1-1-97

DATE	REVISIONS
1-1-13	Corrected notation for flowline (f) on SEDIMENT BASIN ELEVATION
1-1-12	Omitted hay/straw perimeter barrier. Added SLICE METHOD to SECTION A-A

TEMPORARY EROSION CONTROL SYSTEMS

(Sheet 1 of 2)

STANDARD 280001-07

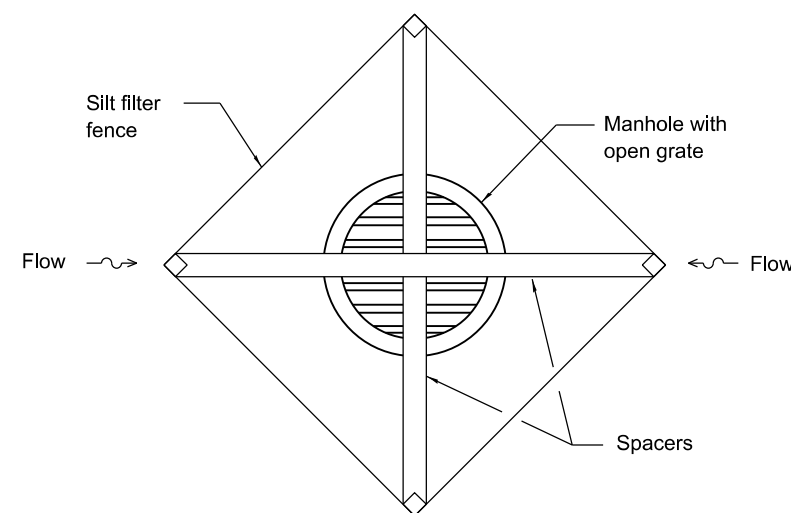
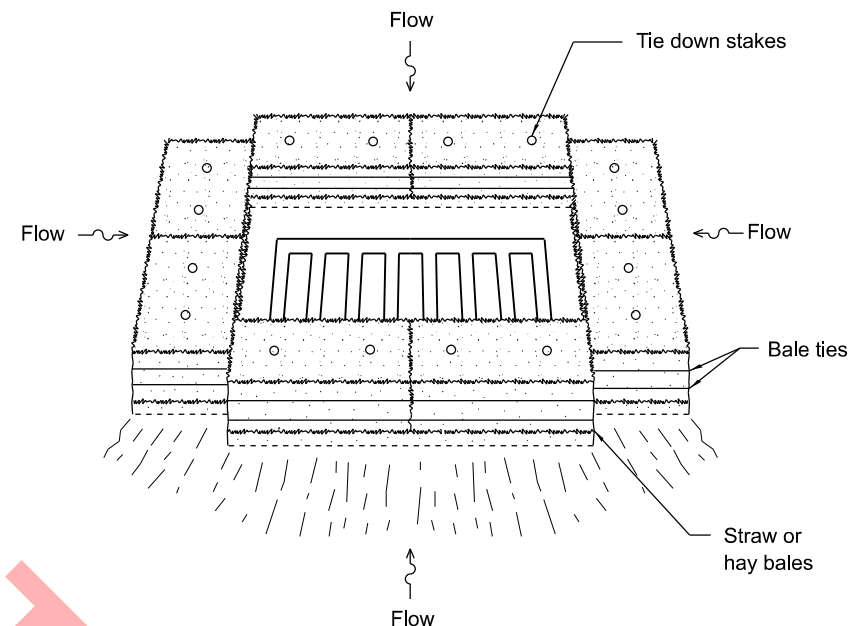
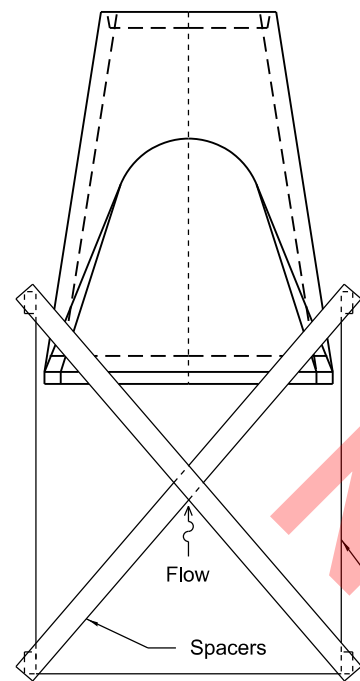
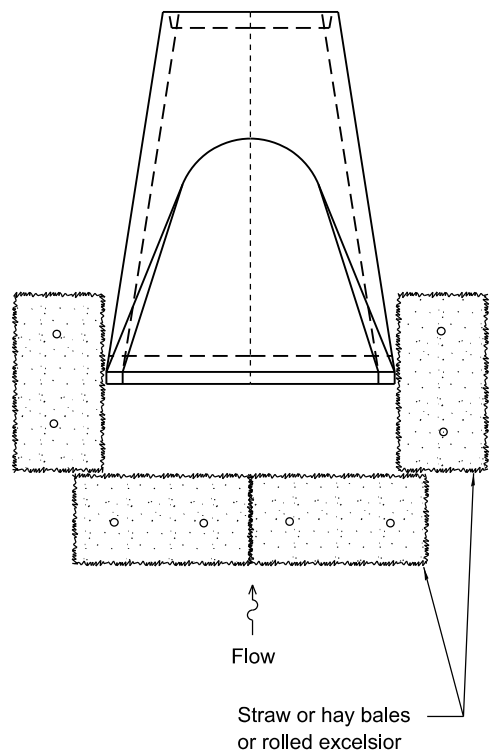

INLET AND PIPE PROTECTION

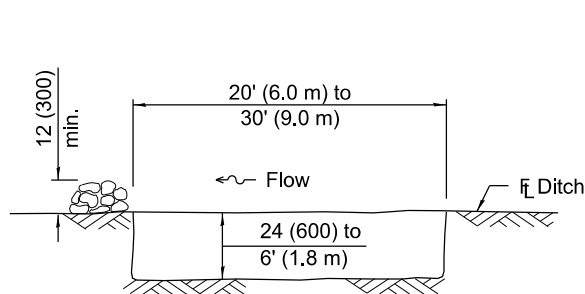

The performance of the basin will improve if put into a series.

ELEVATION

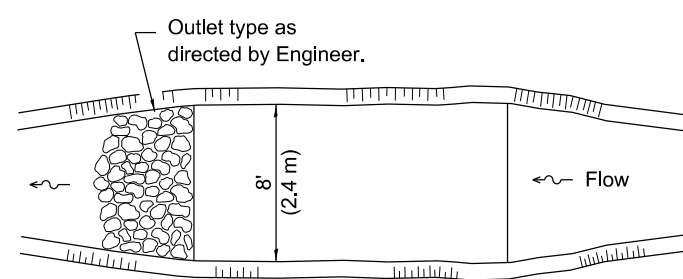

The long dimension should be parallel with the direction of the flow. Accumulated silt shall be removed anytime the basins become 75% filled.

PLAN

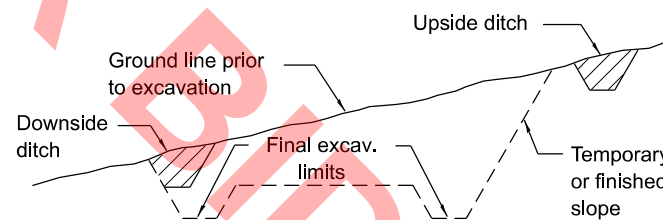

TYPICAL CUT CROSS-SECTION

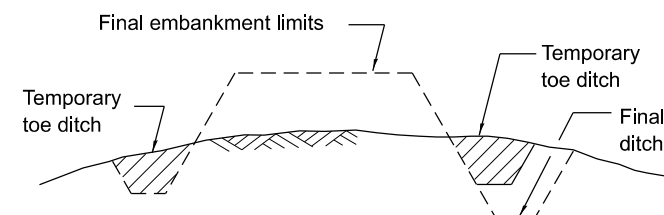

TYPICAL FILL CROSS-SECTION

TEMPORARY DITCHES FOR CUT & FILL SECTIONS

SEDIMENT BASIN

Illinois Department of Transportation
 APPROVED January 1, 2013
 Michael Brand
 ENGINEER OF POLICY AND PROCEDURES
 APPROVED January 1, 2013
 ENGINEER OF DESIGN AND ENVIRONMENT

ISSUED 1-1-97

TEMPORARY EROSION CONTROL SYSTEMS

(Sheet 2 of 2)

STANDARD 280001-07

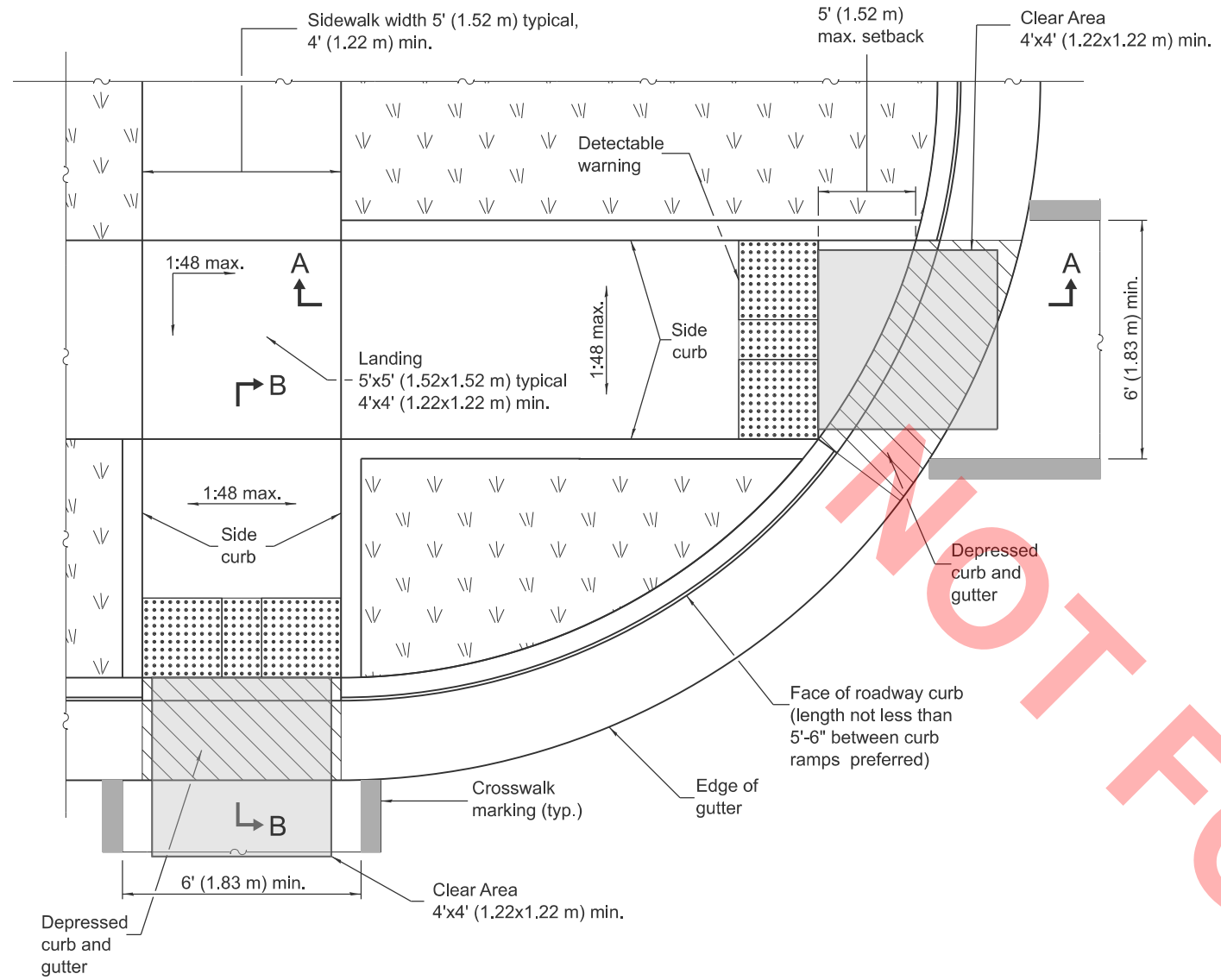

**RAMPS IN LANDSCAPED AREA
SETBACK ≤ 5'**

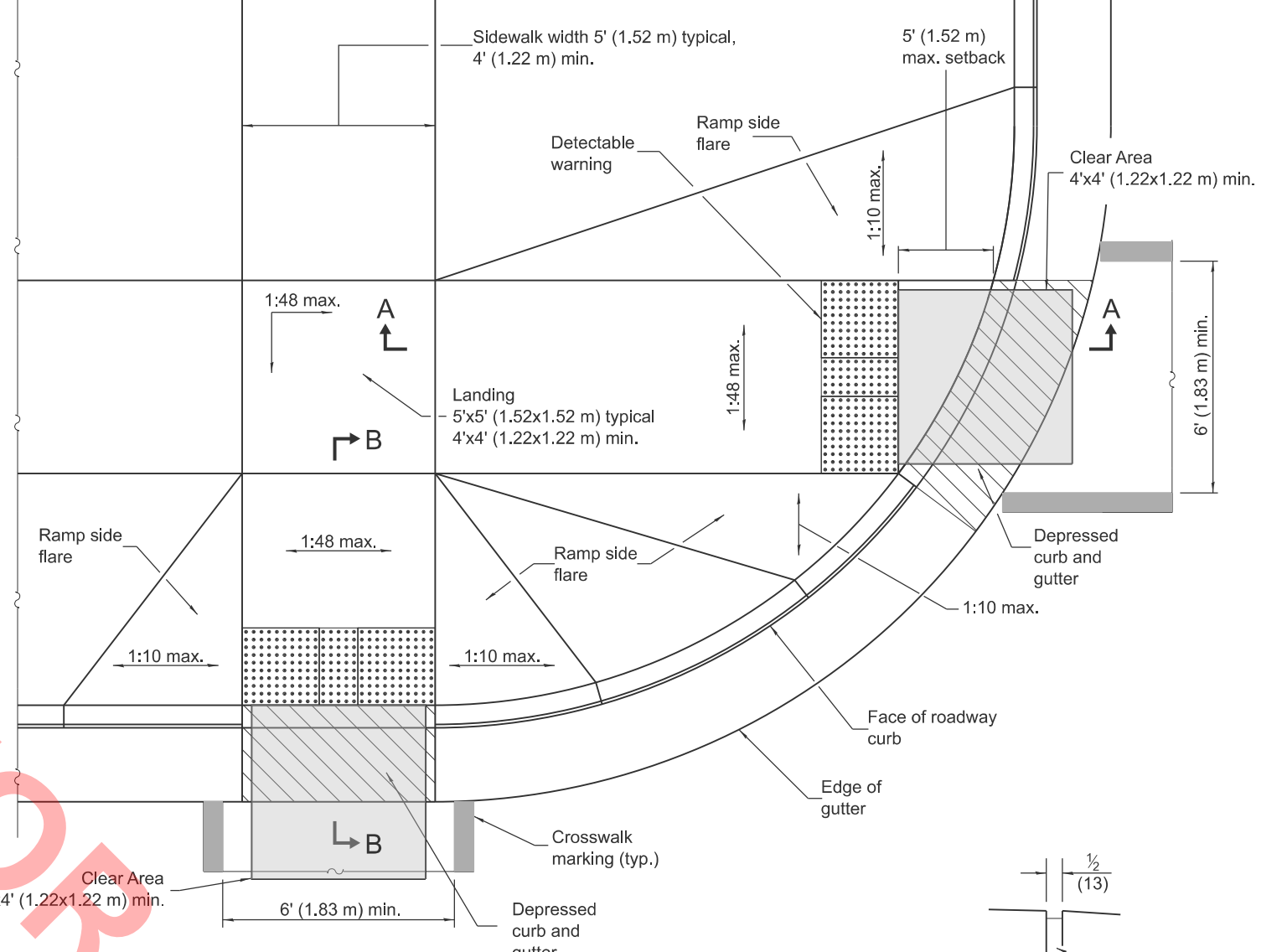

**RAMPS IN PAVED AREA
SETBACK ≤ 5'**

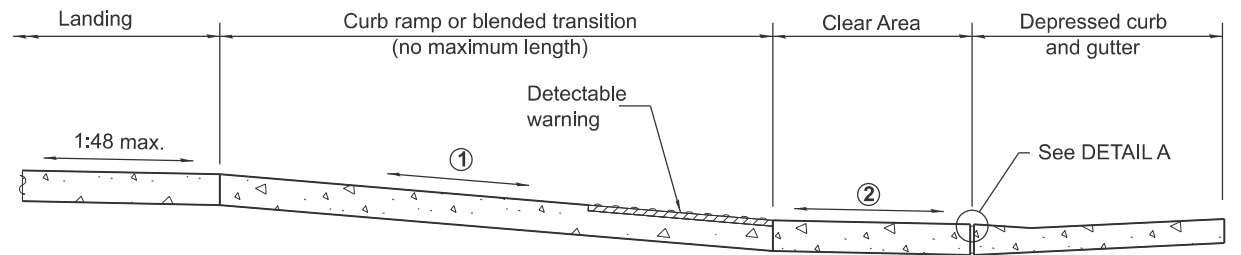
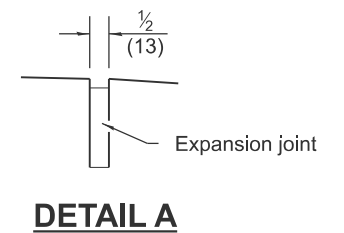

SECTION A-A

- ① The running slope of a curb ramp shall be 1:12 max. The running slope of a blended transition shall be 1:20 max.
- ② Clear Area shall be located outside the travel lane inclusive of any bicycle lanes. The running slope shall be 1:20 max and the cross slope shall be:
 - Signalized/Uncontrolled Intersection - 1:20
 - Yield/Stop Controlled Intersection - 1:48
 - Midblock - grade of the road

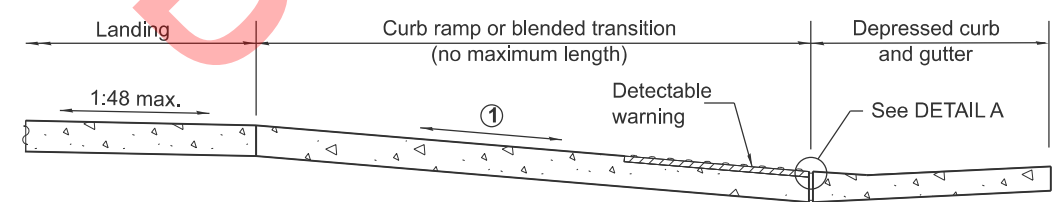

SECTION B-B

- ① The running slope of a curb ramp shall be 1:12 max. The running slope of a blended transition shall be 1:20 max.

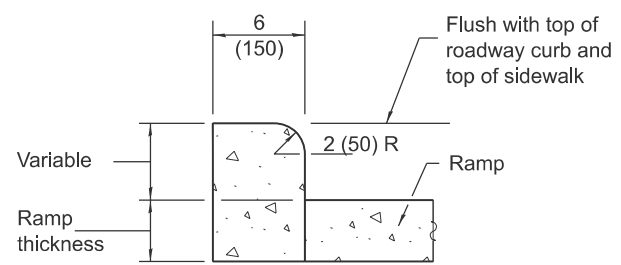

SIDE CURB DETAIL

See Sheet 2 for GENERAL NOTES.

DATE	REVISIONS
1-1-25	Indicated "Clear Area" Location and updated cross-slopes.
1-1-19	Removed "15-foot rule", added "Blended transitions" and placement tolerances for detectable warnings.

**PERPENDICULAR CURB
RAMPS FOR SIDEWALKS**

(Sheet 1 of 2)

STANDARD 424001-12

Illinois Department of Transportation

APPROVED January 1, 2025
Marshall K. Wood
ENGINEER OF POLICY AND PROCEDURES

APPROVED January 1, 2025
Subh Chak
ENGINEER OF DESIGN AND ENVIRONMENT

ISSUED 1-1-97

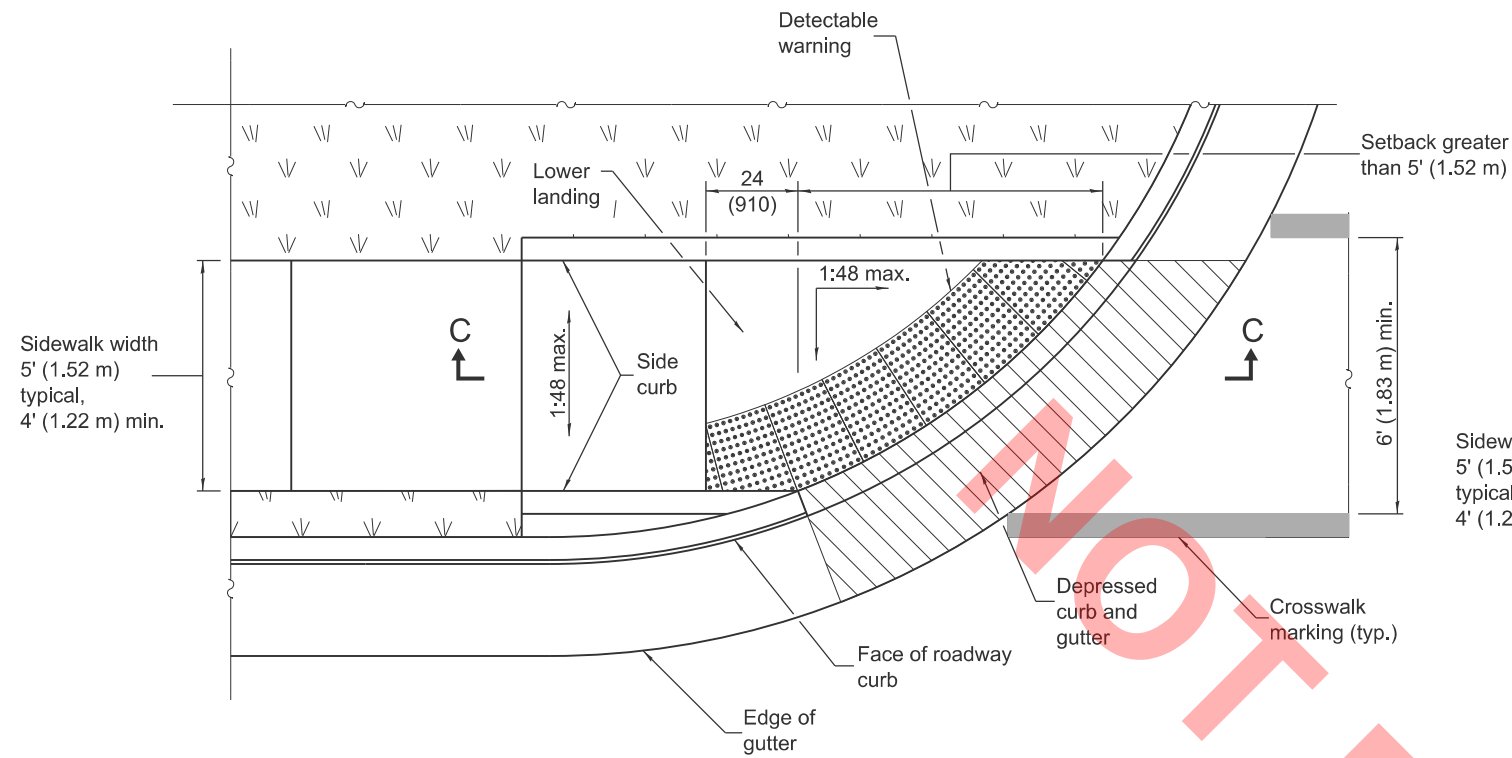

**RAMP IN LANDSCAPED AREA
SETBACK > 5'**

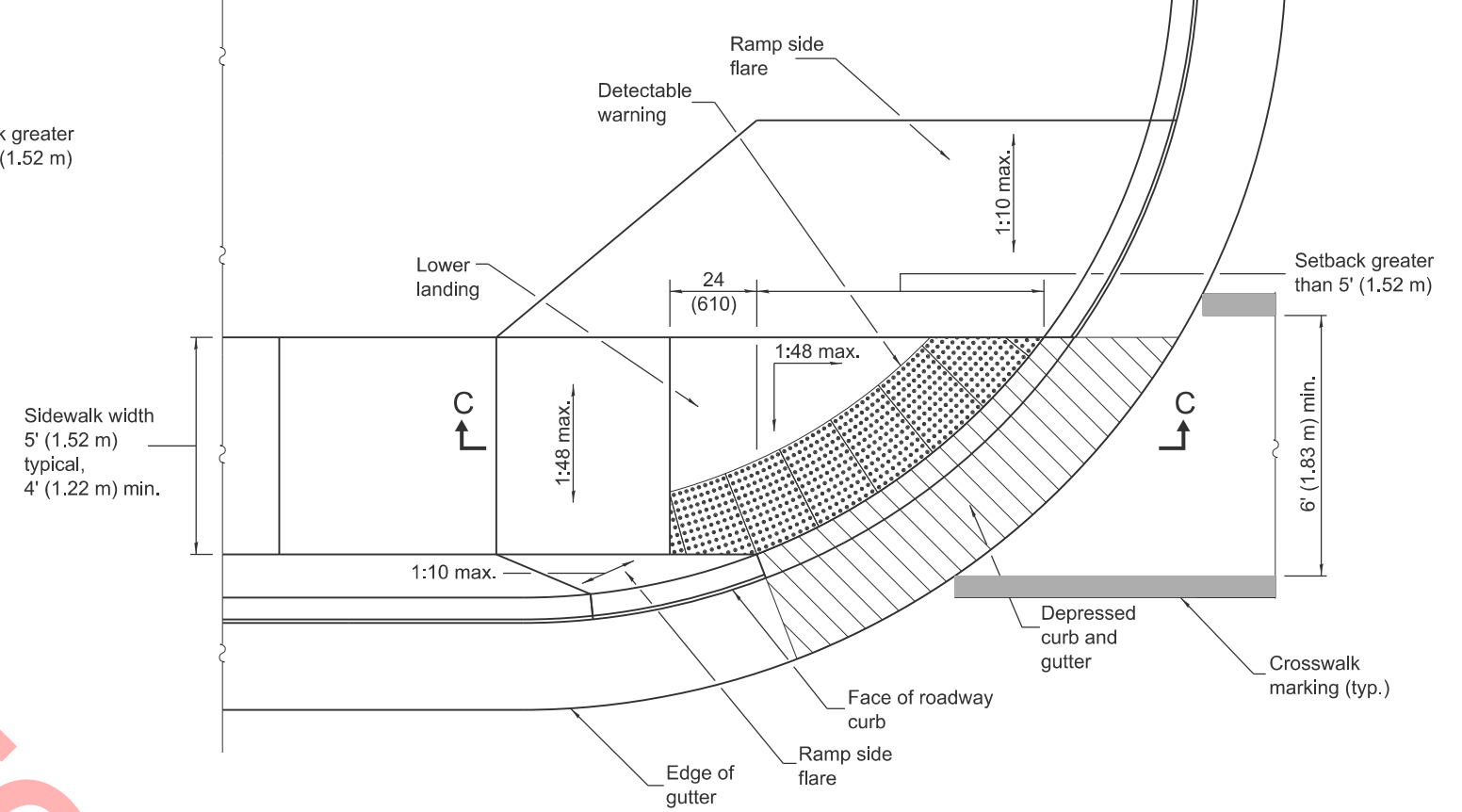

**RAMP IN PAVED AREA
SETBACK > 5'**

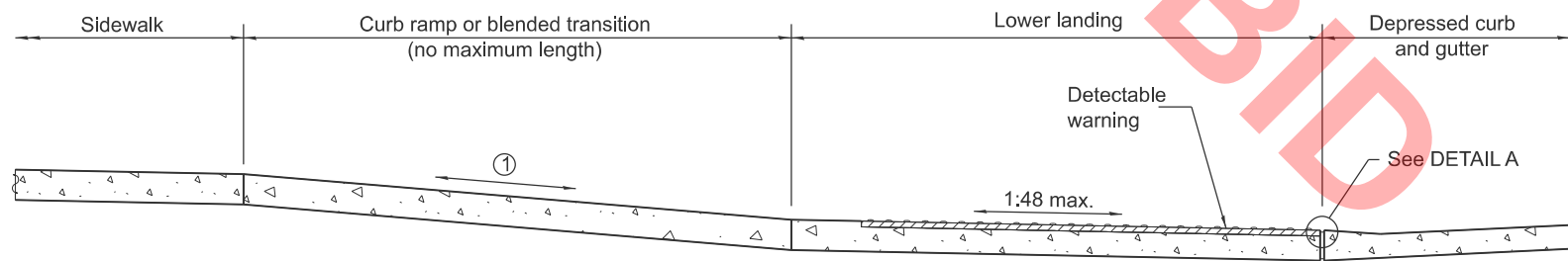

SECTION C-C

- ① The running slope of a curb ramp shall be 1:12 max. The running slope of a blended transition shall be 1:20 max.

GENERAL NOTES

All slope ratios are expressed as units of vertical displacement to units of horizontal displacement (V:H).

Where 1:48 maximum slope is shown, 1:64 is preferred.

Detectable warnings are shown in their ideal locations but the following placement tolerances are allowed.

Side Border - Detectable warnings should extend the full width of the walking surface (excluding flared sides) but a border along each side up to 2 in. (50 mm) in width is allowed.

Curb Set-Back - Detectable warnings located at the back of curb should closely align with the curb but a gap up to 6 in. (150 mm) behind the curb is allowed.

See Standard 606001 for details of depressed curb adjacent to curb ramp.

All dimensions are in inches (millimeters) unless otherwise shown.

Illinois Department of Transportation

APPROVED January 1, 2025
Marshall K. Matell
ENGINEER OF POLICY AND PROCEDURES

APPROVED January 1, 2025
John C. ...
ENGINEER OF DESIGN AND ENVIRONMENT

ISSUED 1-1-97

**PERPENDICULAR CURB
RAMPS FOR SIDEWALKS**

(Sheet 2 of 2)

STANDARD 424001-12

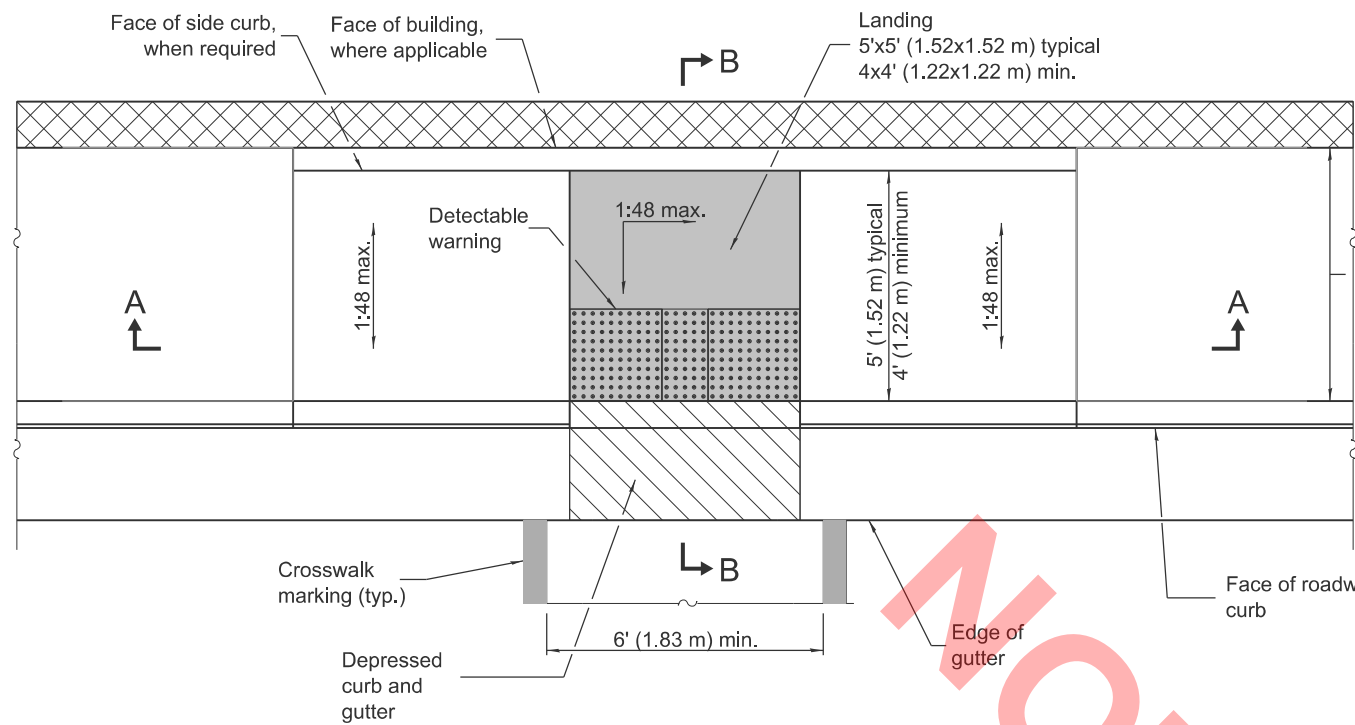

PARALLEL MID-BLOCK CURB RAMP

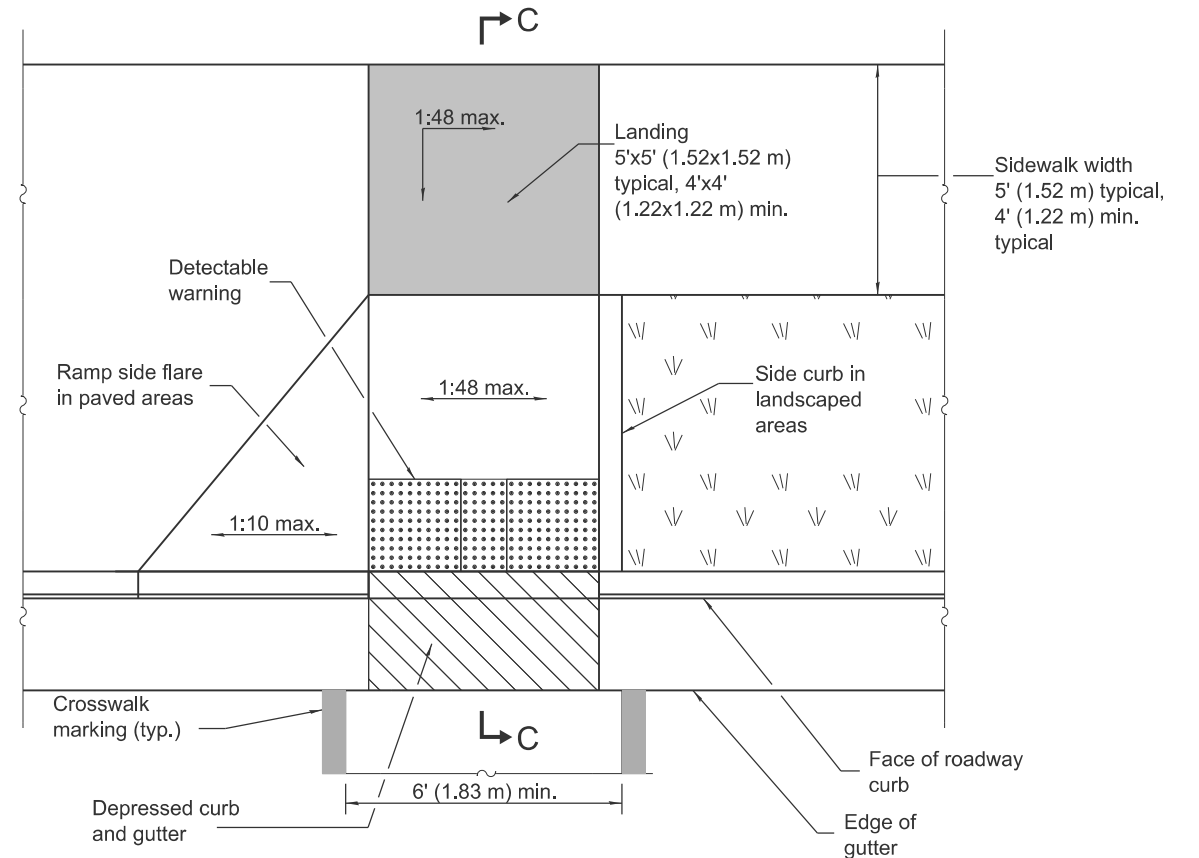

PERPENDICULAR MID-BLOCK CURB RAMP

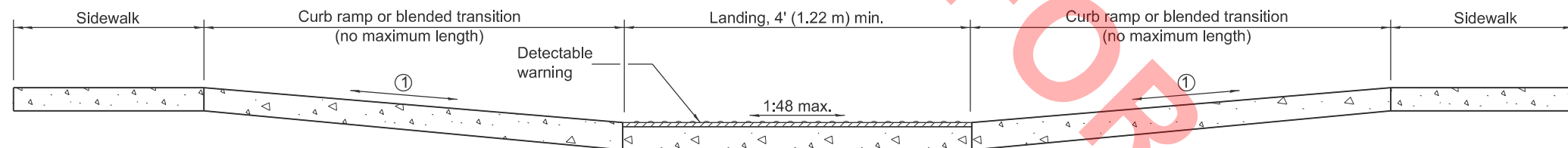

SECTION A-A

① The running slope of a curb ramp shall be 1:12 max. The running slope of a blended transition shall be 1:20 max.

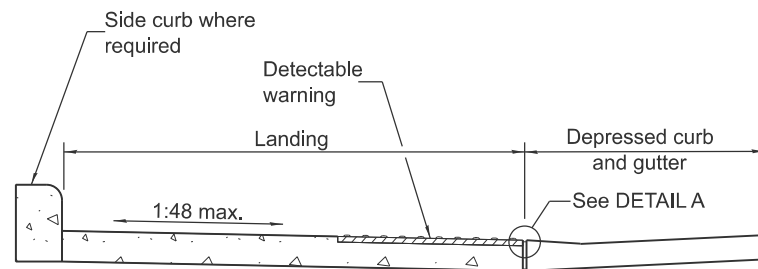

SECTION B-B

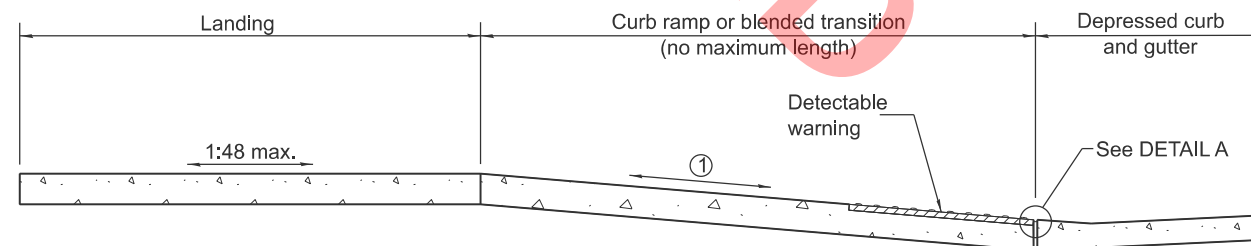

SECTION C-C

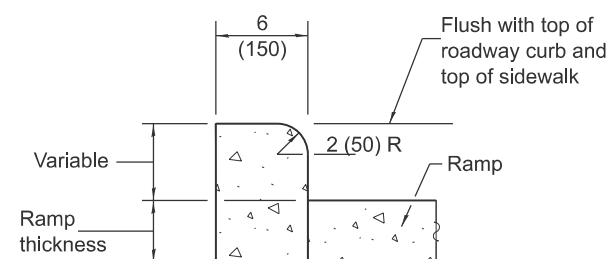

SIDE CURB DETAIL

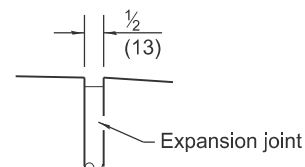

DETAIL A

GENERAL NOTES

All slope ratios are expressed as units of vertical displacement to units of horizontal displacement (V:H).

Where 1:48 maximum slope is shown, 1:64 is preferred.

Detectable warnings are shown in their ideal locations but the following placement tolerances are allowed.

Side Border - Detectable warnings should extend the full width of the walking surface (excluding flared sides) but a border along each side up to 2 in. (50 mm) in. width is allowed.

Curb Set-Back - Detectable warnings located at the back of curb should closely align with the curb but a gap up to 6 in. (150 mm) behind the curb is allowed.

See Standard 606001 for details of depressed curb adjacent to curb ramp.

All dimensions are in inches (millimeters) unless otherwise shown.

DATE	REVISIONS
1-1-25	Revised turning space with landing and updated cross-slope.
1-1-19	Removed upper landing, added blended transitions and detectable warning tolerances.

MID-BLOCK CURB RAMPS FOR SIDEWALKS

STANDARD 424016-06

Illinois Department of Transportation

APPROVED January 1, 2025
Markell K. Metcalf
 ENGINEER OF POLICY AND PROCEDURES

APPROVED January 1, 2025
Scott C. C...
 ENGINEER OF DESIGN AND ENVIRONMENT

ISSUED 1-1-12

CLASS C

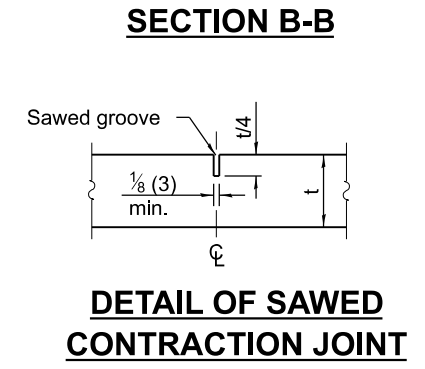
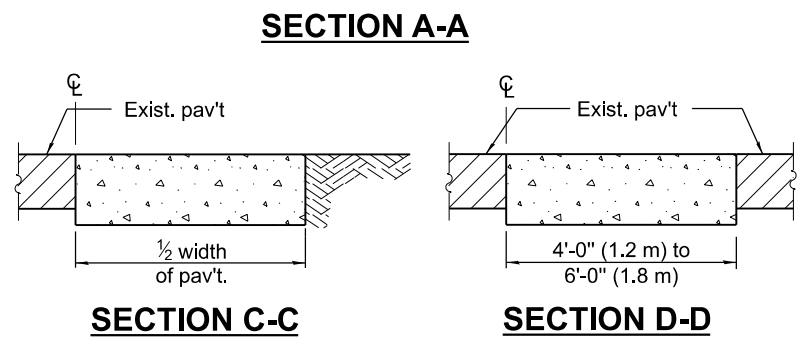
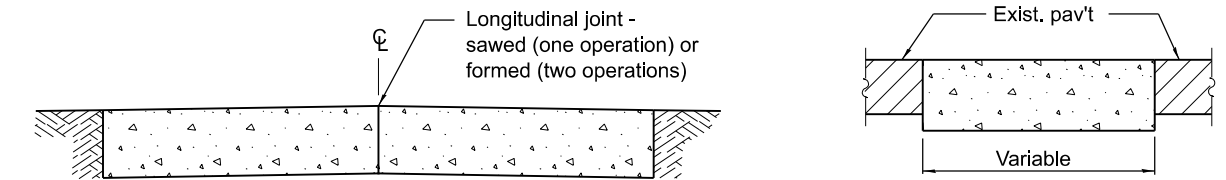
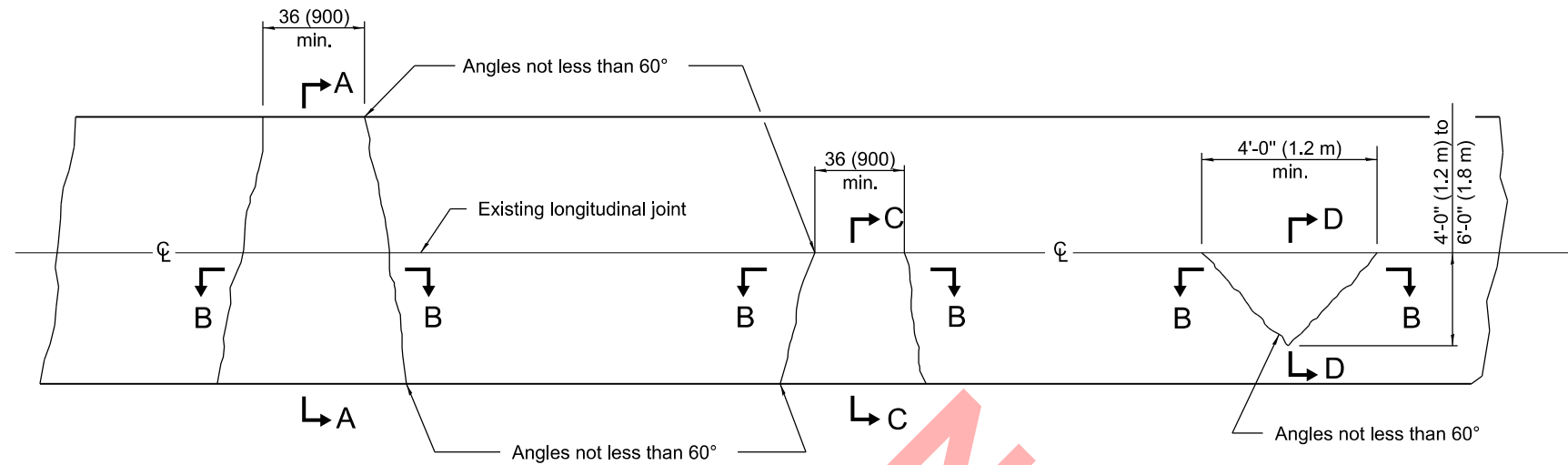

Note:
Longitudinal joints shall be as detailed on Standard 420001, except tie bars are not required for patches 20'-0" (6,0 m) or less in length.

CLASS D

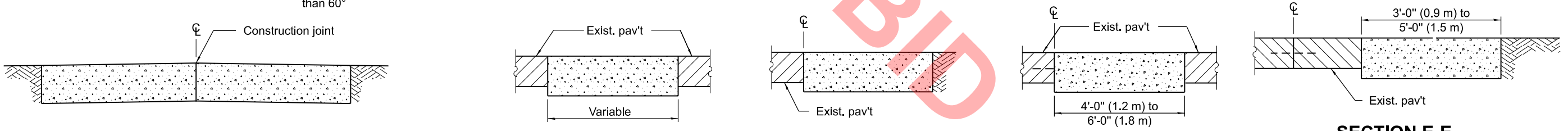
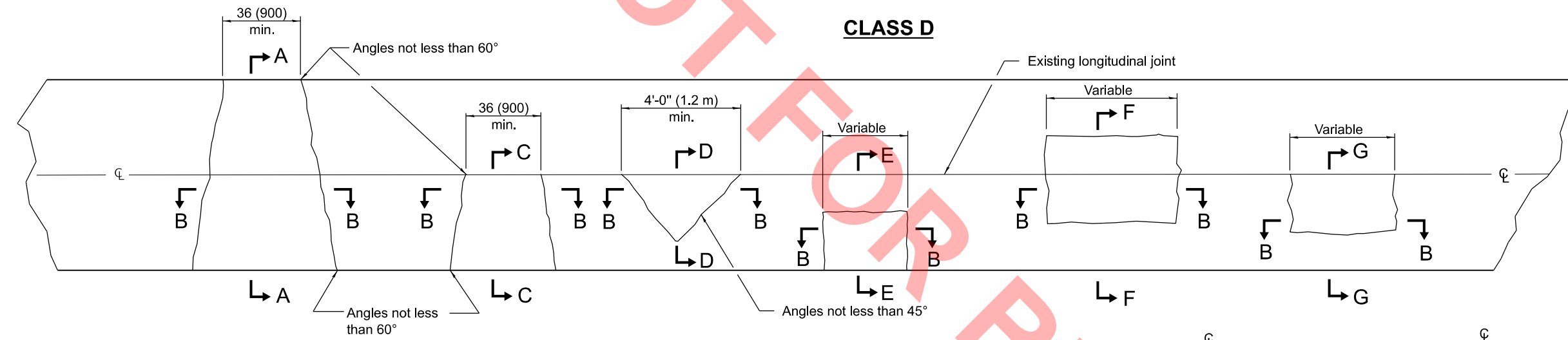

SECTION A-A
(Built in two operations)

SECTION B-B

SECTION C-C

SECTION D-D

SECTION E-E

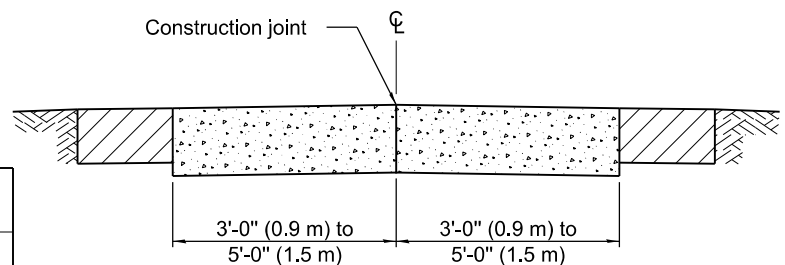

SECTION F-F
(Built in two operations)

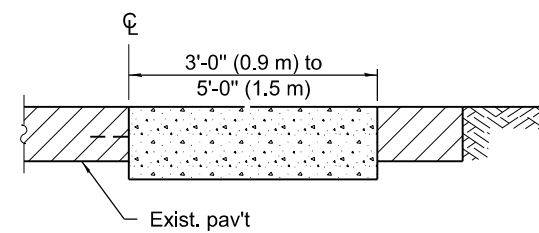

SECTION G-G

GENERAL NOTES

Existing tie bars shall be either cut or removed. Marginal bars shall be cut.

All dimensions are in inches (millimeters) unless otherwise shown.

DATE	REVISIONS
1-1-08	Switched units to English (metric).
1-1-07	Revised Note for Class C patches.

CLASS C and D PATCHES

STANDARD 442201-03

Illinois Department of Transportation

APPROVED January 1, 2008
ENGINEER OF POLICY AND PROCEDURES

APPROVED January 1, 2008
ENGINEER OF DESIGN AND ENVIRONMENT

ISSUED 1-1-97

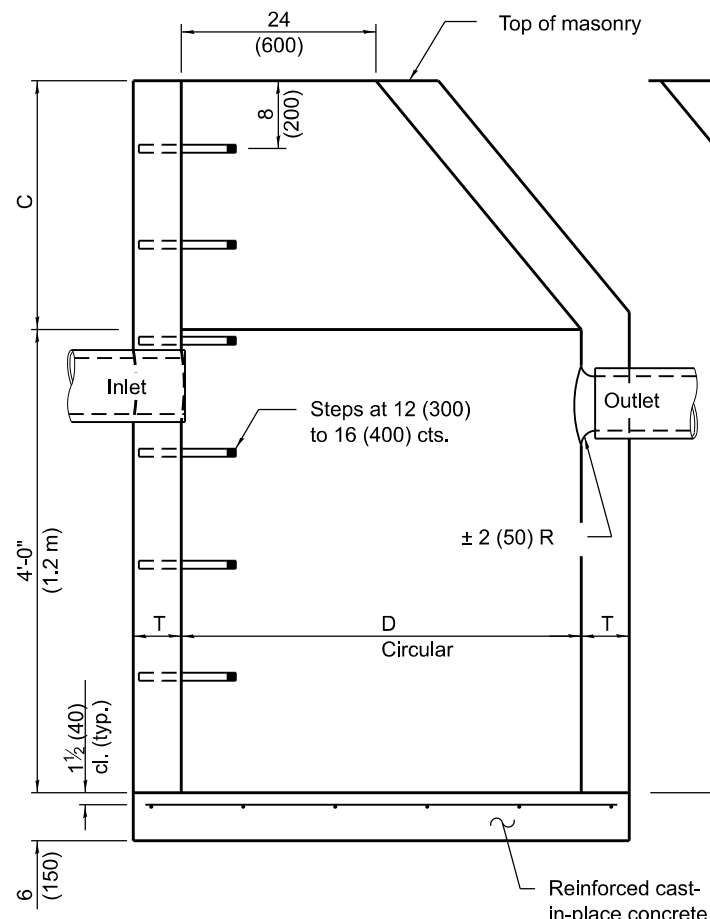

ELEVATION
(Standard Outlet)

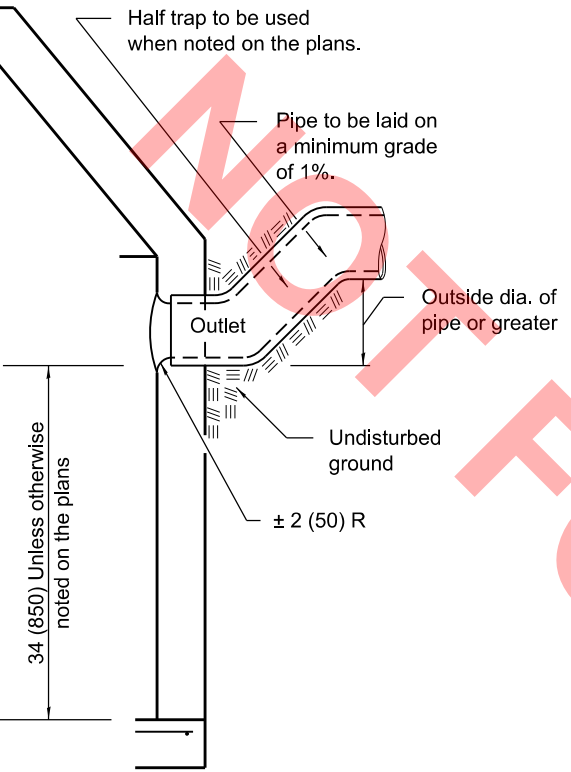

ELEVATION
(Half Trap)

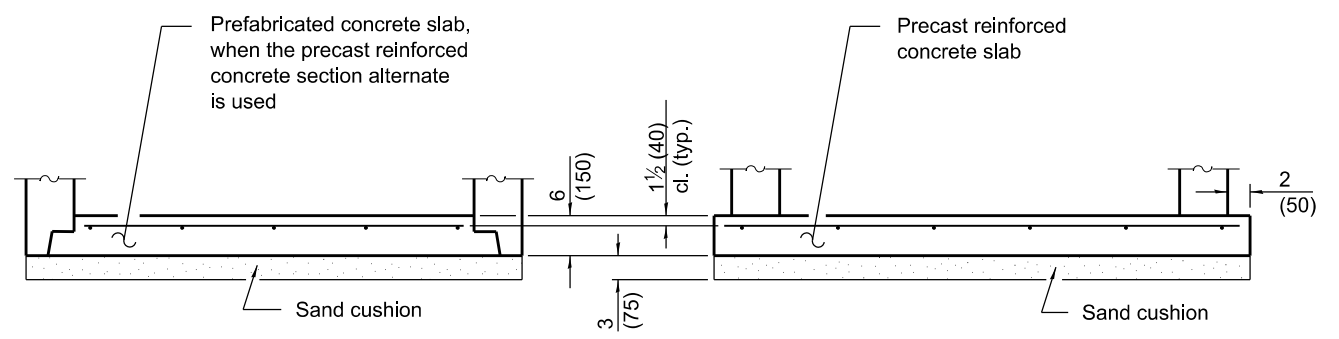

ALTERNATE BOTTOM SLAB

ALTERNATE MATERIALS FOR WALLS	D	C*	T (min.)
Concrete Masonry Unit	4'-0" (1.2 m)	30 (750)	5 (125)
	5'-0" (1.5 m)	3'-9" (1.15 m)	5 (125)
Brick Masonry	4'-0" (1.2 m)	30 (750)	8 (200)
	5'-0" (1.5 m)	3'-9" (1.15 m)	8 (200)
Precast Reinforced Concrete Section	4'-0" (1.2 m)	30 (750)	4 (100)
	5'-0" (1.5 m)	3'-9" (1.15 m)	5 (125)
Cast-in-place Concrete	4'-0" (1.2 m)	30 (750)	6 (150)
	5'-0" (1.5 m)	3'-9" (1.15 m)	6 (150)

* For precast reinforced concrete sections, dimension "C" may vary from the dimension given to plus 6 (150).

GENERAL NOTES

Bottom slabs shall be reinforced with a minimum of 0.20 sq. in./ft (420 sq. mm/m) in both directions with a maximum spacing of 12 (300).

Bottom slabs may be connected to the riser as determined by the fabricator; however, only a single row of reinforcement around the perimeter may be utilized.

See Standard 602601 for optional precast reinforced concrete flat slab top.

See Standard 602701 for details of steps.

All dimensions are in inches (millimeters) unless otherwise shown.

Illinois Department of Transportation

APPROVED January 1, 2011
Michael Brand
ENGINEER OF POLICY AND PROCEDURES

APPROVED January 1, 2011
Scott Schick
ENGINEER OF DESIGN AND ENVIRONMENT

ISSUED 1-1-97

DATE	REVISIONS
1-1-11	Added 'Outside' to half trap note.
	Detail rein. in slabs. Revised
	general notes.
1-1-09	Switched units to English (metric).

**CATCH BASIN
TYPE A**

STANDARD 602001-02

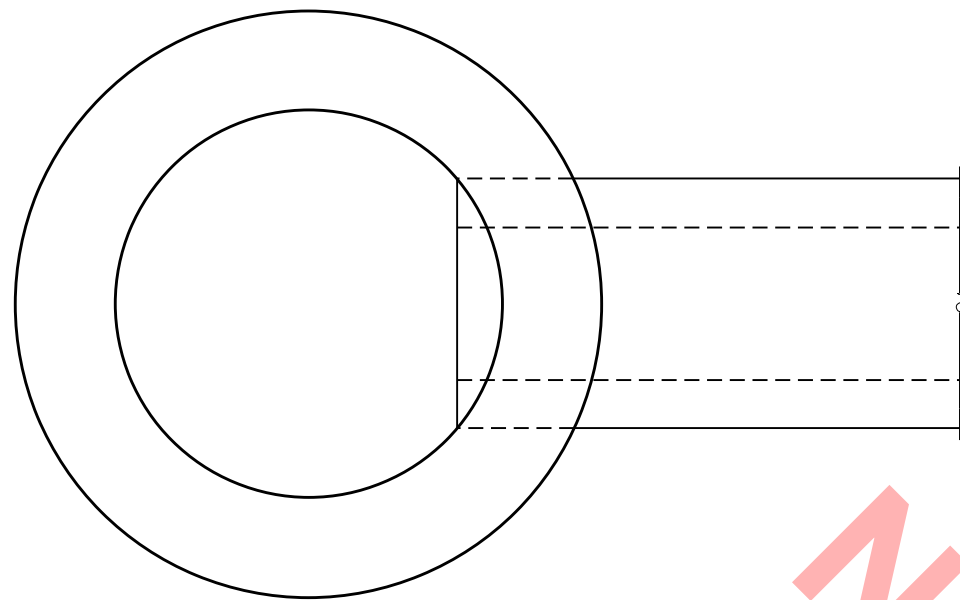

PLAN

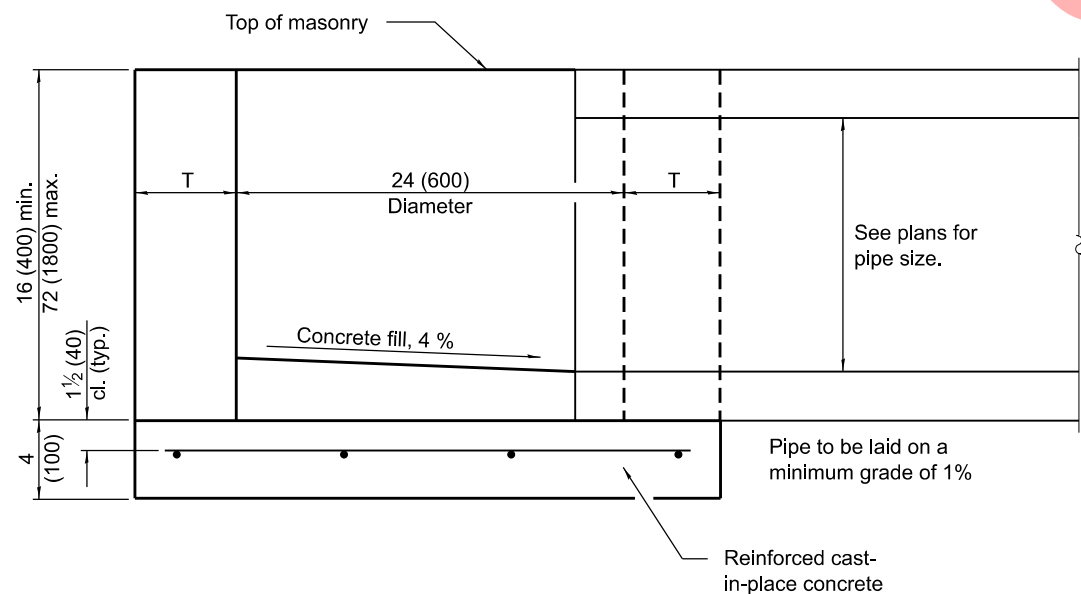

ELEVATION

ALTERNATE MATERIALS FOR WALLS	T
BRICK MASONRY	8 (200)
CAST-IN-PLACE CONCRETE	6 (150)
CONCRETE MASONRY UNIT	5 (125)
PRECAST REINFORCED CONCRETE SECTION	3 (75)

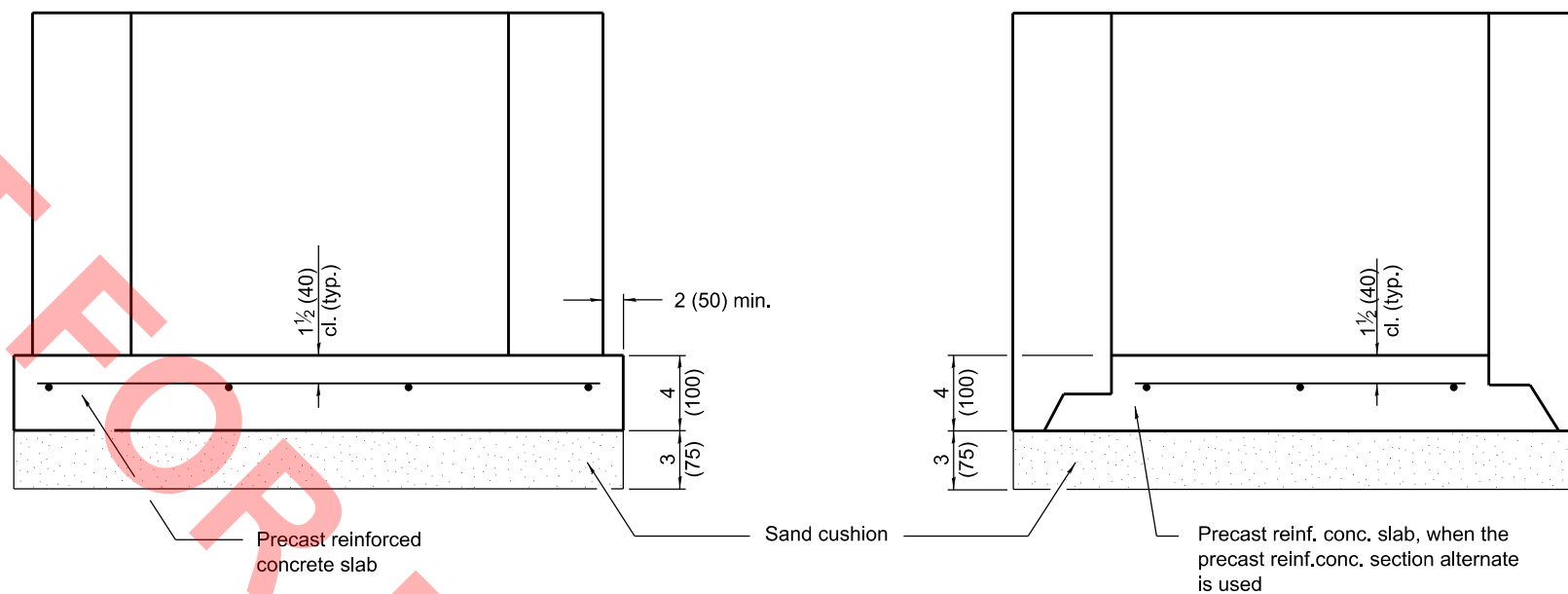

ALTERNATE METHODS

GENERAL NOTES

Bottom slabs shall be reinforced with a minimum of 0.24 sq. in./ft. (510 sq. mm/m) in both directions with a maximum spacing of 10 (250).

Bottom slabs may be connected to the riser as determined by the fabricator; however, only a single row of reinforcement around the perimeter may be utilized.

All dimensions are in inches (millimeters) unless otherwise shown.

DATE	REVISIONS
1-1-14	Increased height to 72 (1800) maximum.
1-1-11	Detailed rein. in slabs. Added max. limit to height. Added general notes.

INLET - TYPE A

STANDARD 602301-04

Illinois Department of Transportation

APPROVED January 1, 2014
Michael Beard
 ENGINEER OF POLICY AND PROCEDURES

APPROVED January 1, 2014
[Signature]
 ENGINEER OF DESIGN AND ENVIRONMENT

ISSUED 1-1-97

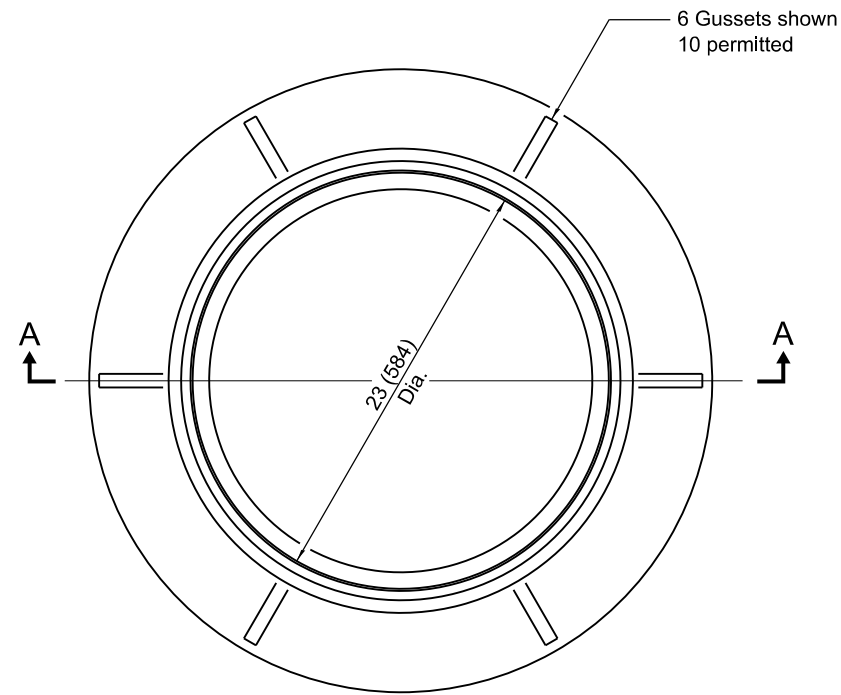

CAST FRAME

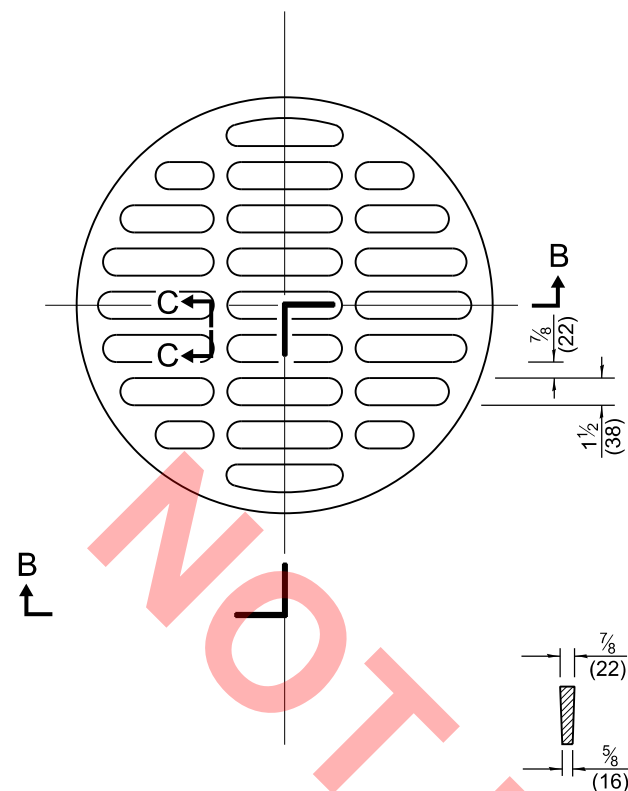

SECTION C-C

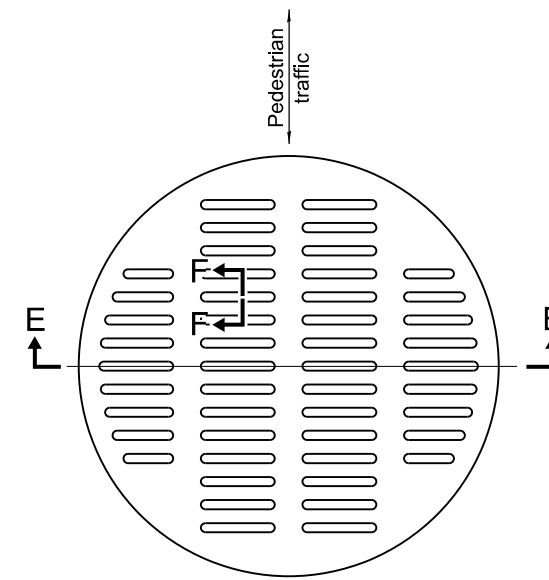

SECTION F-F

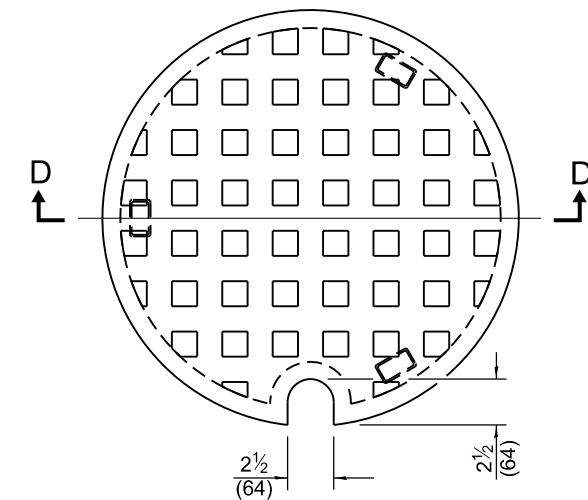

SECTION D-D

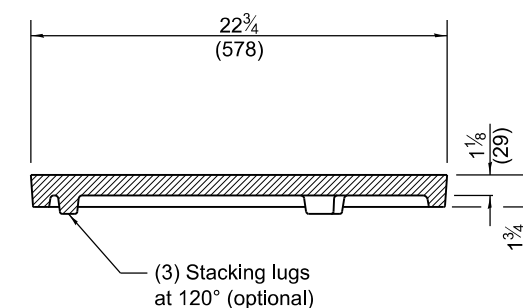

CAST CLOSED LID
Gray Iron Lid

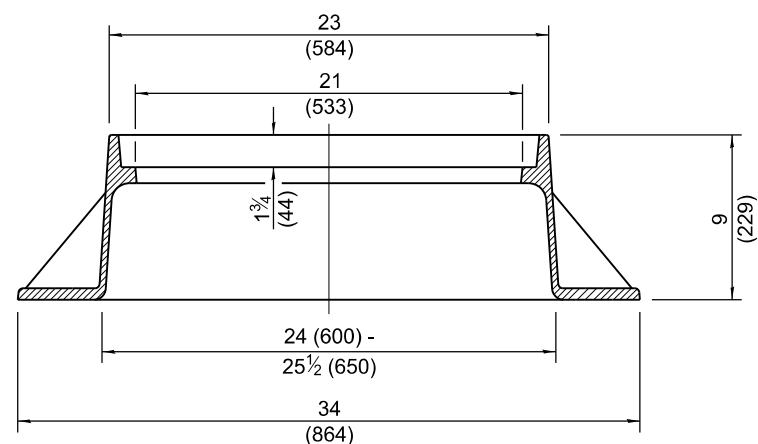

SECTION A-A
Gray Iron

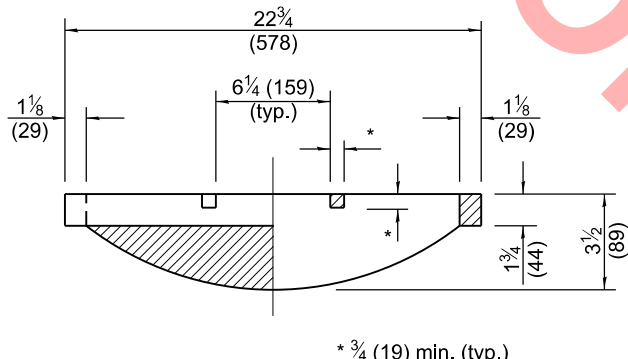

SECTION B-B

CAST OPEN LID

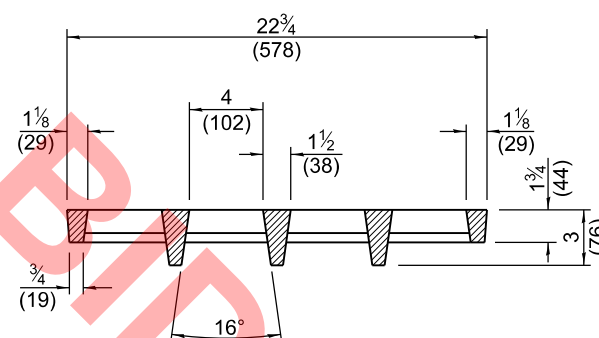

SECTION E-E

**ADA COMPLIANT
CAST OPEN LID**

All dimensions are in inches (millimeters) unless otherwise shown.

Illinois Department of Transportation

APPROVED January 1, 2020
Michael Bond
ENGINEER OF POLICY AND PROCEDURES

APPROVED January 1, 2020
J. E. Egan
ENGINEER OF DESIGN AND ENVIRONMENT

ISSUED 1-1-97

DATE	REVISIONS
1-1-20	Revised dimension in Section B-B of cast open lid.
1-1-15	Revised dimensioning of frame.
	Added ADA compliant open lid.

**FRAME AND LIDS
TYPE 1**

STANDARD 604001-05

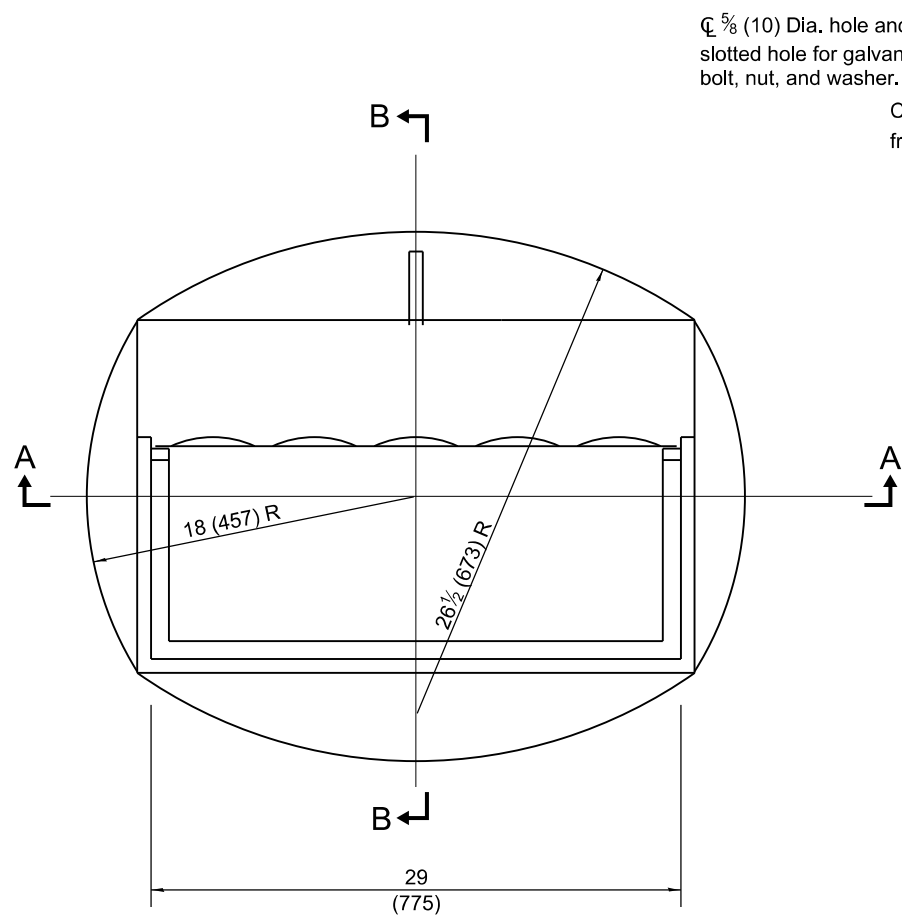

CAST FRAME

☐ 5/8 (10) Dia. hole and 5/8x5 1/2 (16x140) slotted hole for galvanized 1/2 (M12) bolt, nut, and washer.
Curb box adjustable from 4 1/2 (115) to 9 (225)

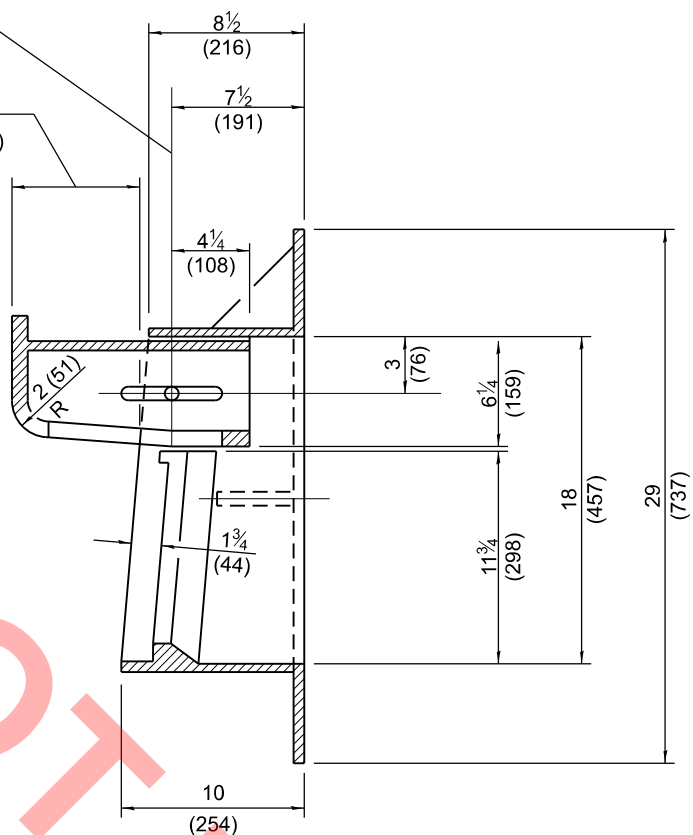

SECTION B-B

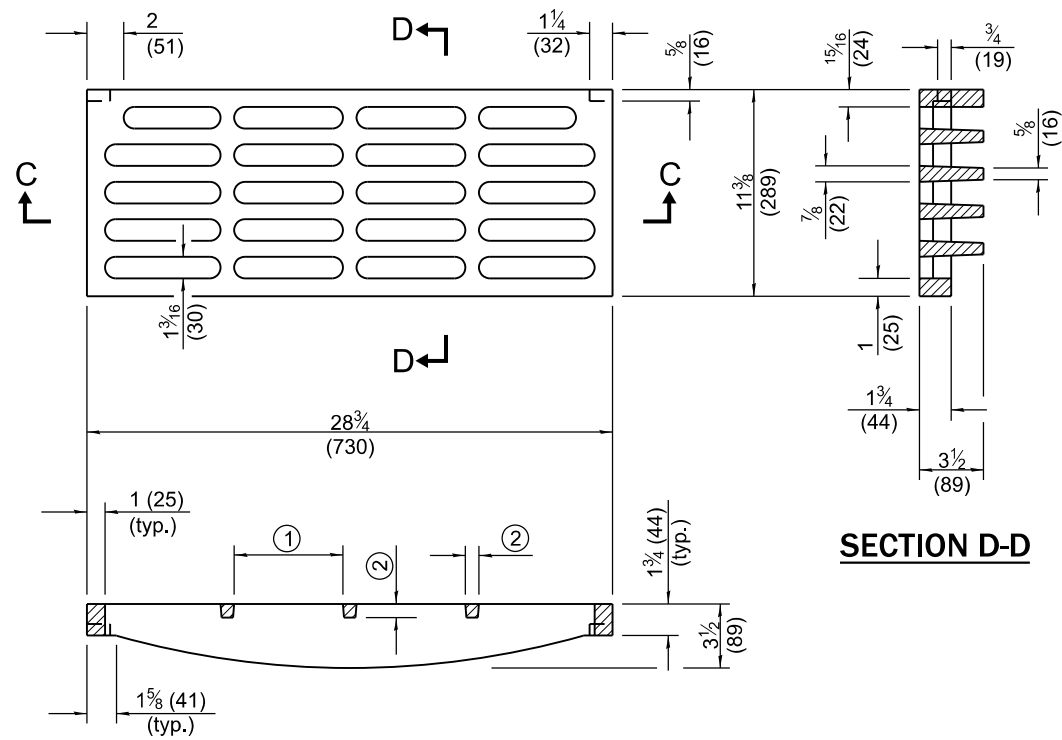

SECTION C-C

- ① = 6 1/4 (159) max. (typ.)
- ② = 3/4 (19) min. (typ.)

CAST GRATE

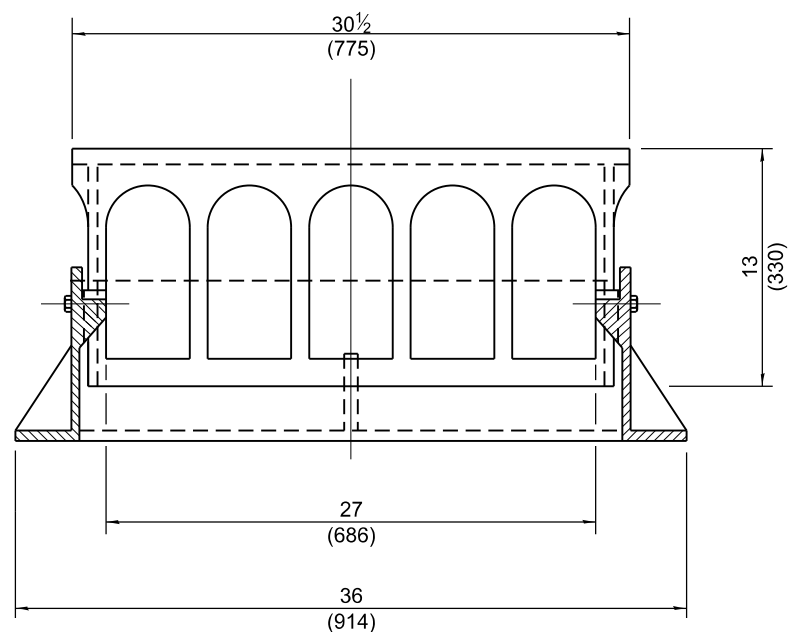

SECTION A-A

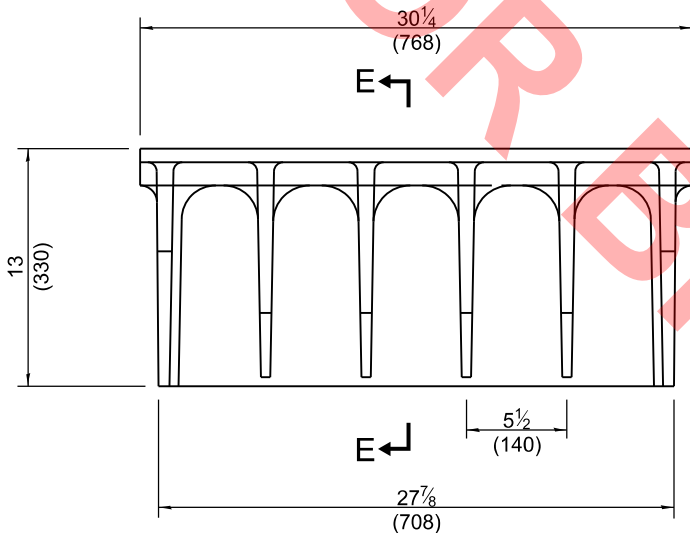

ALTERNATE CURB BOX

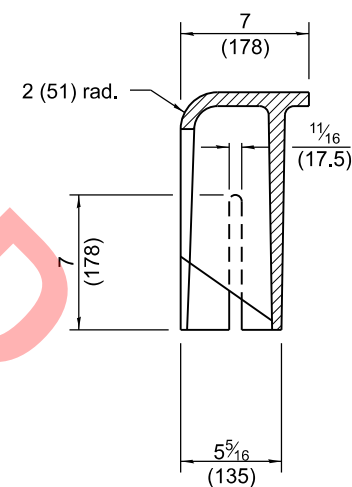

SECTION E-E

All dimensions are in inches (millimeters) unless otherwise shown.

Illinois Department of Transportation

APPROVED January 1, 2015
Michael Brand
ENGINEER OF POLICY AND PROCEDURES

APPROVED January 1, 2015
[Signature]
ENGINEER OF DESIGN AND ENVIRONMENT

ISSUED 1-1-97

DATE	REVISIONS
1-1-15	Revised dimensions of frame and alternate curb box.
4-1-09	Switched units to English (metric).

**FRAME AND GRATE
TYPE 11**

STANDARD 604051-04

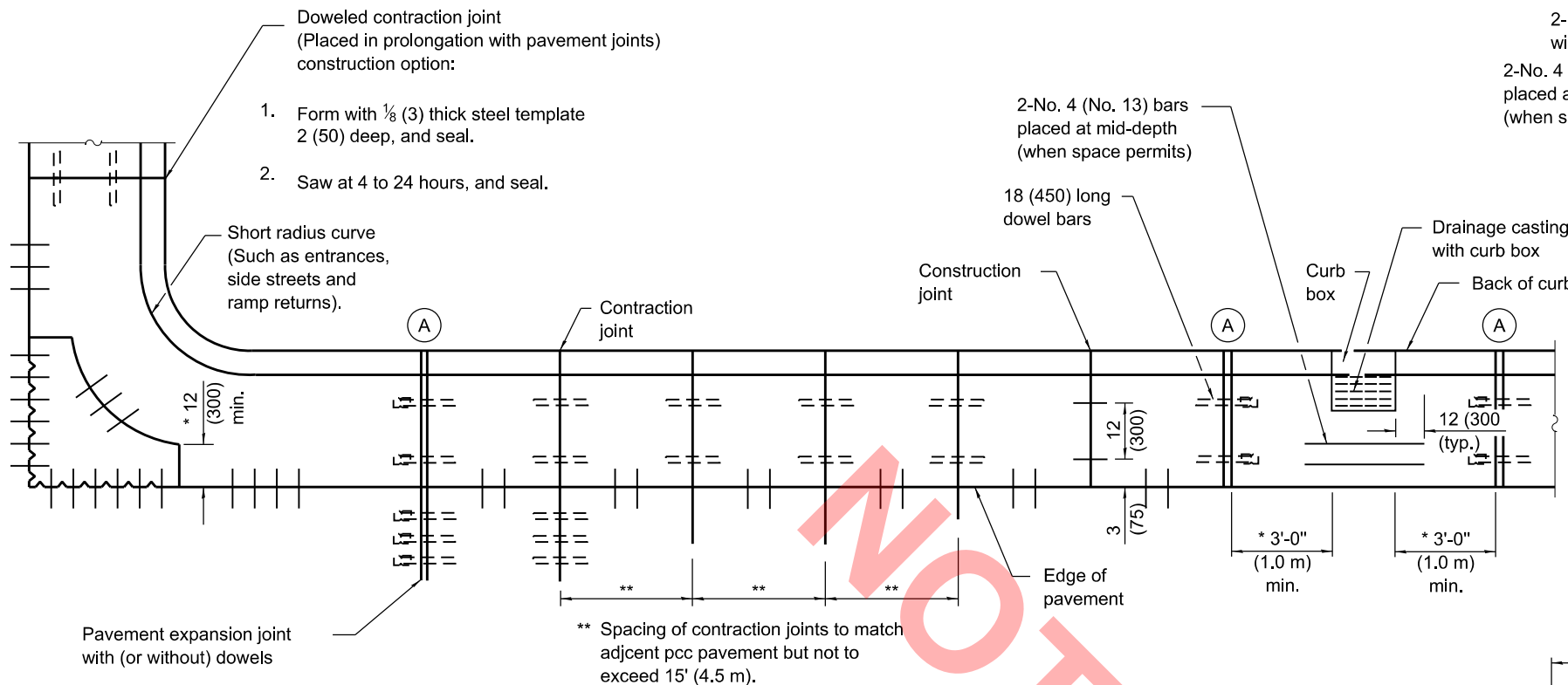

PLAN
ADJACENT TO PCC PAVEMENT OR PCC BASE COURSE

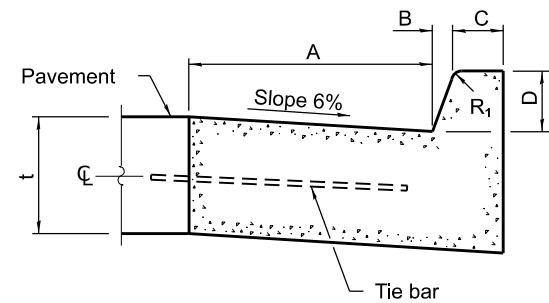

BARRIER CURB

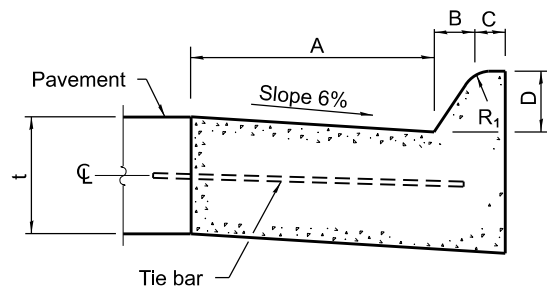

MOUNTABLE CURB

TABLE OF DIMENSIONS BARRIER CURB					
TYPE	A	B	C	D	R ₁
B-6.06 *	6	1	6	6	1
(B-15.15)	(150)	(25)	(150)	(150)	(25)
B-6.12	12	1	6	6	1
(B-15.3)	(300)	(25)	(150)	(150)	(25)
B-6.18	18	1	6	6	1
(B-15.45)	(450)	(25)	(150)	(150)	(25)
B-6.24	24	1	6	6	1
(B-15.60)	(600)	(25)	(150)	(150)	(25)
B-9.12	12	2	5	9	1
(B-22.30)	(300)	(50)	(125)	(225)	(25)
B-9.18	18	2	5	9	1
(B-22.45)	(450)	(50)	(125)	(225)	(25)
B-9.24	24	2	5	9	1
(B-22.60)	(600)	(50)	(125)	(225)	(25)

* For corner islands only.

TABLE OF DIMENSIONS MOUNTABLE CURB						
TYPE	A	B	C	D	R ₁	R ₂
M-2.06	6	2	4	2	3	2
(M-5.15)	(150)	(50)	(100)	(50)	(75)	(50)
M-2.12	12	2	4	2	3	2
(M-5.30)	(300)	(50)	(100)	(50)	(75)	(50)
M-4.06	6	4	3	4	3	NA
(M-10.15)	(150)	(100)	(75)	(100)	(75)	NA
M-4.12	12	4	3	4	3	NA
(M-10.30)	(300)	(100)	(75)	(100)	(75)	NA
M-4.18	18	4	3	4	3	NA
(M-10.45)	(450)	(100)	(75)	(100)	(75)	NA
M-4.24	24	4	3	4	3	NA
(M-10.60)	(600)	(100)	(75)	(100)	(75)	NA
M-6.06	6	6	2	6	2	NA
(M-15.15)	(150)	(150)	(50)	(150)	(50)	NA
M-6.12	12	6	2	6	2	NA
(M-15.30)	(300)	(150)	(50)	(150)	(50)	NA
M-6.18	18	6	2	6	2	NA
(M-15.45)	(450)	(150)	(50)	(150)	(50)	NA
M-6.24	24	6	2	6	2	NA
(M-15.60)	(600)	(150)	(50)	(150)	(50)	NA

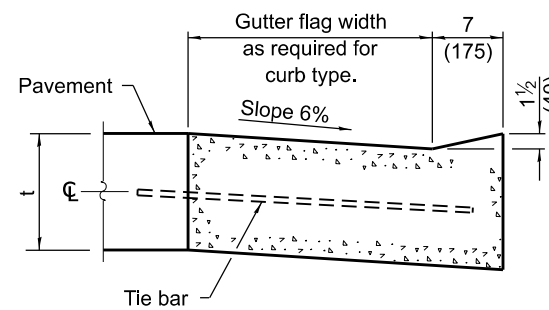

DEPRESSED CURB (TYPICAL)

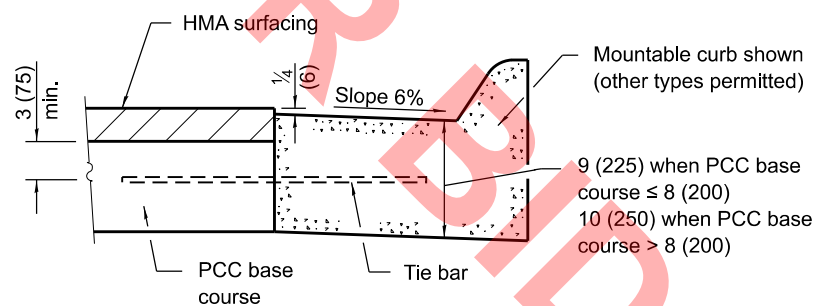

ADJACENT TO PCC BASE COURSE WITH HMA SURFACING

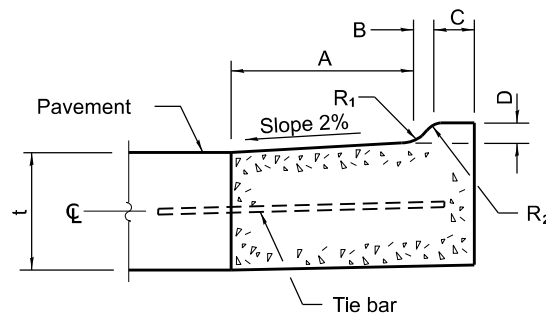

M-2.06 (M-5.15) and M-2.12 (M-5.30)

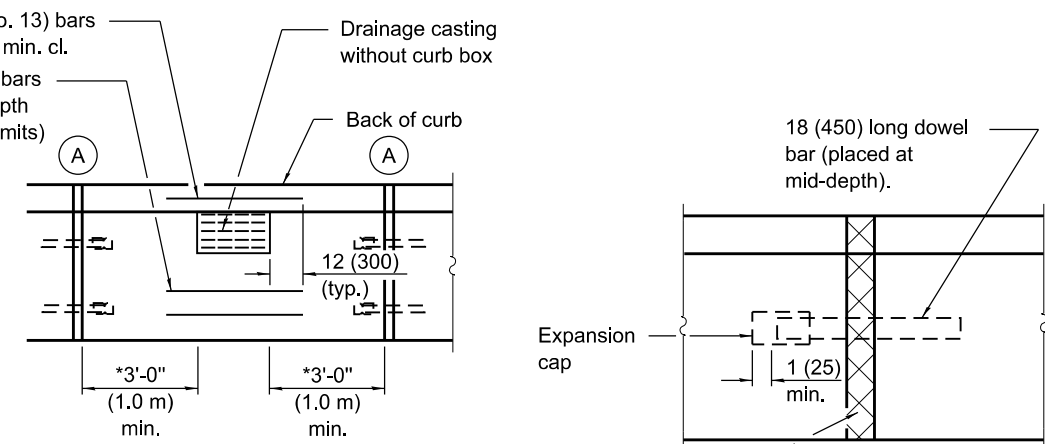

DETAIL A
EXPANSION JOINT

Full depth & width 1 (25) - thick (min.) preformed expansion joint filler.

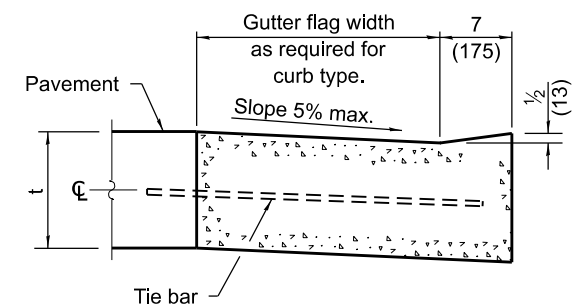

DEPRESSED CURB ADJACENT TO CURB RAMP ACCESSIBLE TO THE DISABLED

GENERAL NOTES

The bottom slope of combination curb and gutter constructed adjacent to pcc pavement shall be the same slope as the subbase or 6% when subbase is omitted.

t = Thickness of pavement.

Longitudinal joint tie bars shall be No. 6 (No. 19) at 36 (900) centers in accordance with details for longitudinal construction joint shown on Standard 420001.

A minimum clearance of 2 (50) between the end of the tie bar and the back of the curb shall be maintained.

The dowel bars shown in contraction joints will only be required for monolithic construction.

See Standard 606301 for details of corner islands.

All dimensions are in inches (millimeters) unless otherwise shown.

DATE	REVISIONS
1-1-22	Revised contract joint spacing adjacent to pcc pavement.
1-1-18	Revised General Note for tie bar spacing to 36 (900) cts.

CONCRETE CURB TYPE B AND COMBINATION CONCRETE CURB AND GUTTER
(Sheet 1 of 2)

STANDARD 606001-08

Illinois Department of Transportation

APPROVED January 1, 2022
Michael Brand
ENGINEER OF POLICY AND PROCEDURES

APPROVED January 1, 2022
John C. ...
ENGINEER OF DESIGN AND ENVIRONMENT

ISSUED 1-1-97

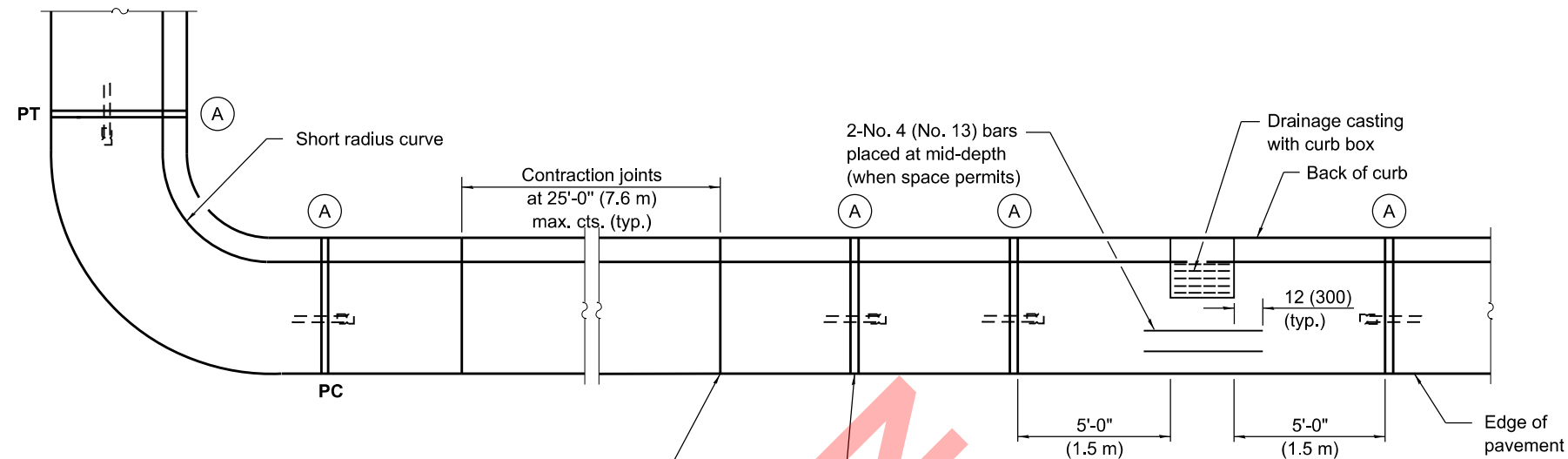

Undoweled contraction joint (typ.) construction options:

1. Form with $\frac{1}{8}$ (3) thick steel template 2 (50) deep, and seal.
2. Saw 2 (50) deep at 4 to 24 hours, and seal.
3. Insert $\frac{3}{4}$ (20) thick preformed joint filler full depth and width.

Construction joint

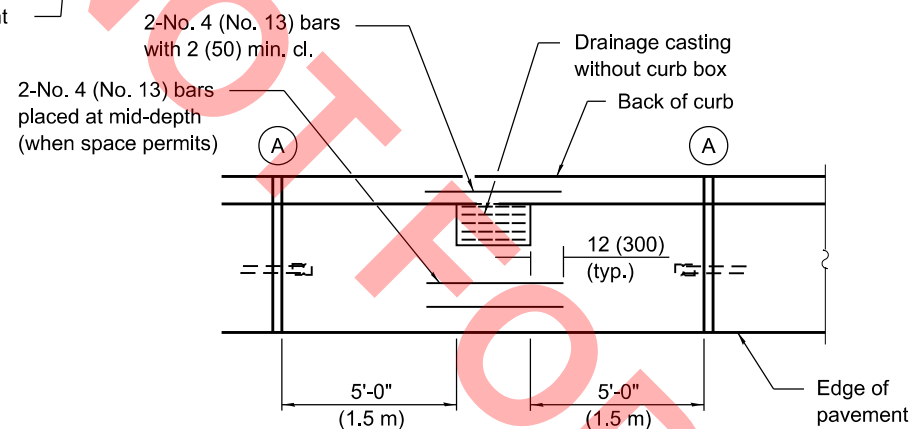

PLAN

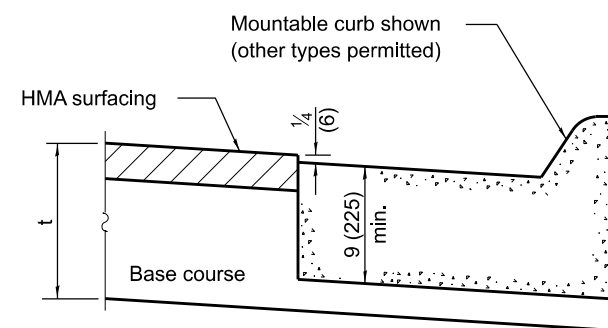

ON DISTURBED SUBGRADE

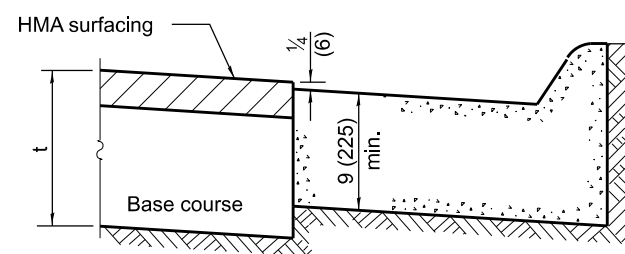

ON UNDISTURBED SUBGRADE

ADJACENT TO FLEXIBLE PAVEMENT

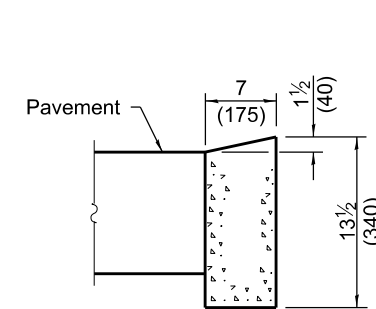

DEPRESSED CURB

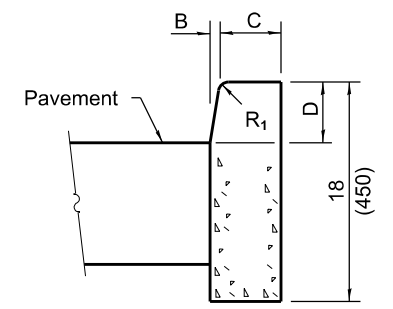

BARRIER CURB

ADJACENT TO FLEXIBLE PAVEMENT

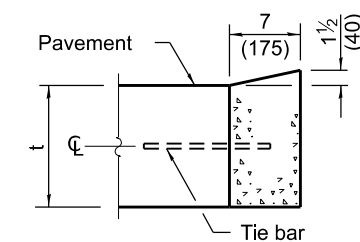

DEPRESSED CURB

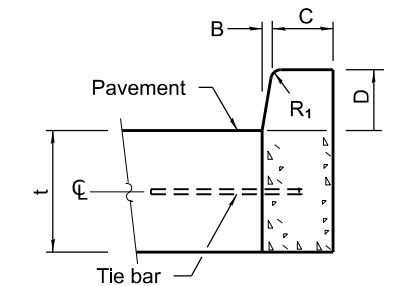

BARRIER CURB

ADJACENT TO PCC PAVEMENT OR PCC BASE COURSE

CONCRETE CURB TYPE B

**CONCRETE CURB TYPE B
AND COMBINATION
CONCRETE CURB AND GUTTER**
(Sheet 2 of 2)

STANDARD 606001-08

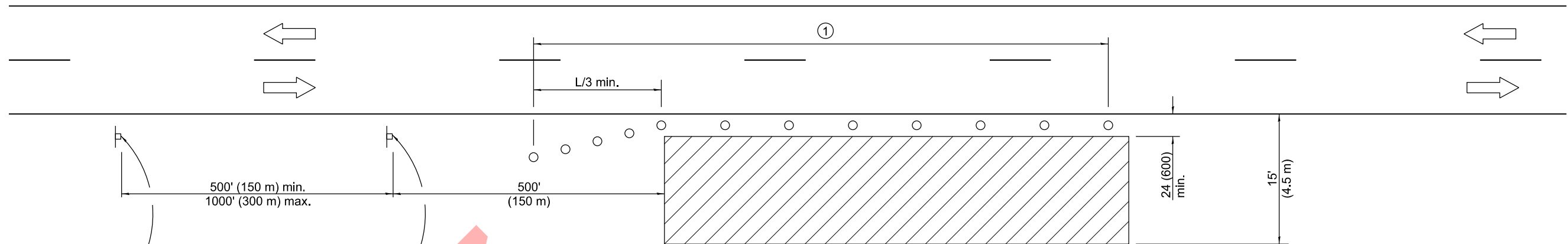

For contract construction projects

ROAD CONSTRUCTION AHEAD

W20-1103(0)-48

W21-1(0)-48

For maintenance and utility projects



ROAD WORK AHEAD

W20-1(0)-48

TYPICAL APPLICATIONS

- Utility operations
- Culvert extensions
- Side slope changes
- Guardrail installation and maintenance
- Delineator installation
- Landscaping operations
- Shoulder repair
- Sign installation and maintenance

SYMBOLS

-  Work area
-  Sign
-  Cone, drum or barricade

① When the work operation exceeds one hour, cones, drums or barricades shall be placed at 25' (8 m) centers for L/3 distance, and at 50' (15 m) centers through the remainder of the work area.

GENERAL NOTES

This Standard is used where any vehicles, equipment, workers or their activities will encroach in the area 15' (4.5 m) to 24 (600) from the edge of pavement.

Calculate L as follows:

SPEED LIMIT	FORMULAS	
	English	(Metric)
40 mph (70 km/h) or less:	$L = \frac{WS^2}{60}$	$L = \frac{WS^2}{150}$
45 mph (80 km/h) or greater:	$L=(W)(S)$	$L=0.65(W)(S)$

W = Width of offset in feet (meters).

S = Normal posted speed mph (km/h).

All dimensions are in inches (millimeters) unless otherwise shown.

DATE	REVISIONS
1-1-14	Revised workers sign number to agree with current MUTCD.
1-1-13	Omitted text 'WORKERS' sign.

OFF-RD OPERATIONS, 2L, 2W, 15' (4.5 m) TO 24" (600 mm) FROM PAVEMENT EDGE

STANDARD 701006-05

Illinois Department of Transportation

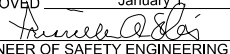
APPROVED January 1, 2014

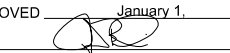
 ENGINEER OF SAFETY ENGINEERING

APPROVED January 1, 2014

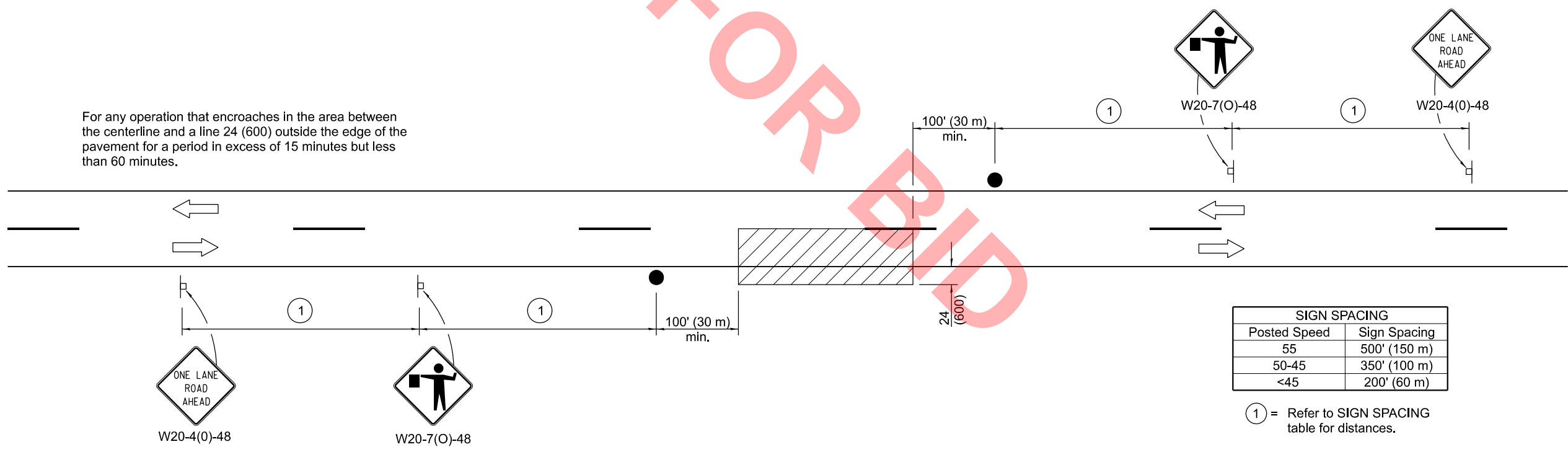
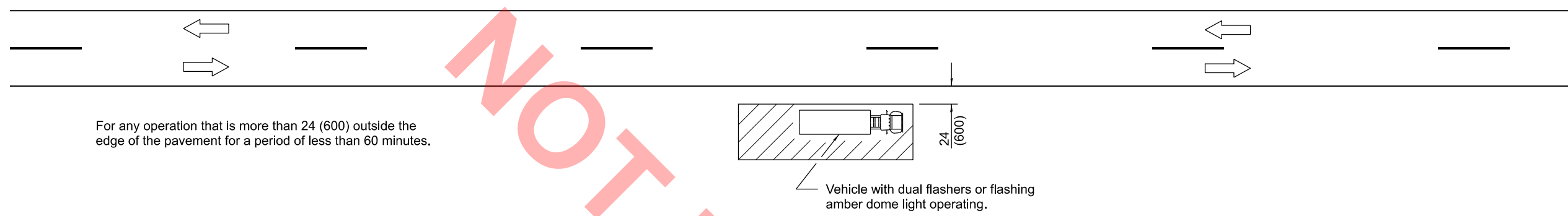
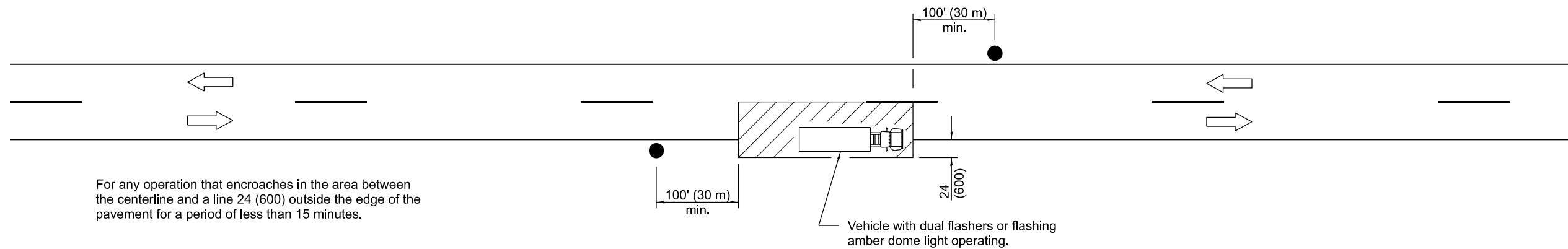
 ENGINEER OF DESIGN AND ENVIRONMENT

ISSUED 1-1-97



SIGN SPACING	
Posted Speed	Sign Spacing
55	500' (150 m)
50-45	350' (100 m)
<45	200' (60 m)

① = Refer to SIGN SPACING table for distances.

TYPICAL APPLICATIONS

- Marking patches
- Field survey
- String line
- Utility operations
- Cleaning up debris on pavement

SYMBOLS

- Work area
- Sign on portable or permanent support
- Flagger with traffic control sign

All dimensions are in inches (millimeters) unless otherwise shown.

Illinois Department of Transportation

APPROVED January 1, 2011
Amelia A. Davis
 ENGINEER OF SAFETY ENGINEERING

APPROVED January 1, 2011
Scott Schickel
 ENGINEER OF DESIGN AND ENVIRONMENT

ISSUED 1-1-97

DATE	REVISIONS
1-1-11	Revised flagger sign.
1-1-09	Switched units to English (metric).

**LANE CLOSURE, 2L, 2W,
SHORT TIME OPERATIONS**

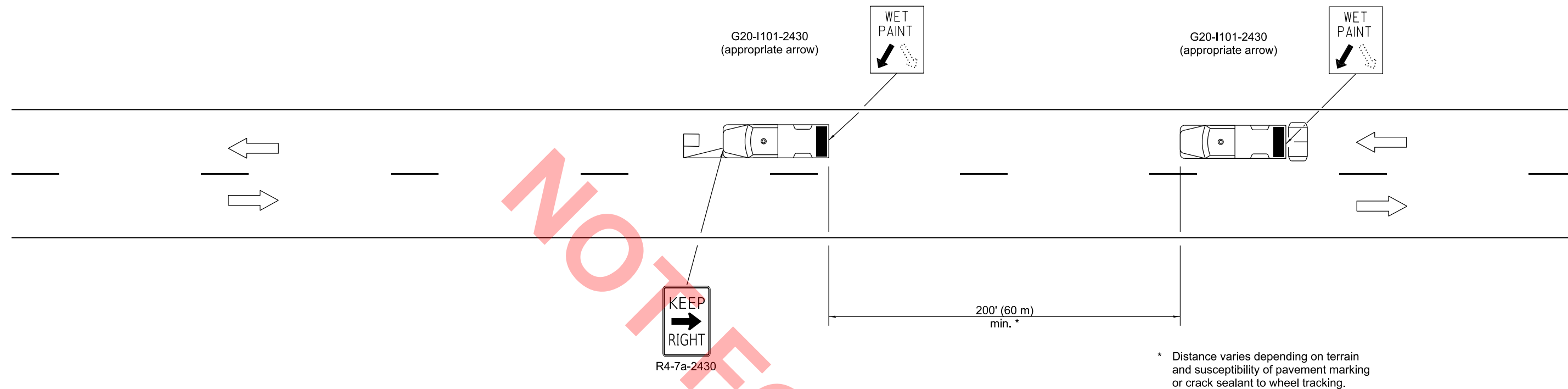

STANDARD 701301-04



TYPICAL APPLICATIONS

- Landscaping work
- Utility work
- Pavement marking
- Weed spraying
- Roadometer measurements
- Debris cleanup
- Crack pouring

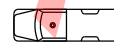
SYMBOLS

-  Arrow board (Hazard Mode only)
-  Truck with headlights, emergency flashers and flashing amber light. (visible from all directions)
-  18 x 18 (450x450) min. orange flag (use when guide wheel is used)
-  Truck mounted attenuator

GENERAL NOTES

This Standard is used where any vehicle, equipment, workers or their activities will require a continuous moving operation where the average speed is greater than 3 mph (5 km/h).

For shoulder operations not encroaching on the pavement, use DETAIL A, Standard 701426.

All dimensions are in inches (millimeters) unless otherwise shown.

Illinois Department of Transportation

APPROVED January 1, 2009
[Signature]
ENGINEER OF OPERATIONS

APPROVED January 1, 2009
[Signature]
ENGINEER OF DESIGN AND ENVIRONMENT

ISSUED 1-1-97

DATE	REVISIONS
1-1-09	Switched units to English (metric). Omitted Pass With Care sign.
1-1-00	Eliminated speed restrictions in Standard title.

**LANE CLOSURE 2L, 2W
MOVING OPERATIONS-
DAY ONLY**

STANDARD 701311-03

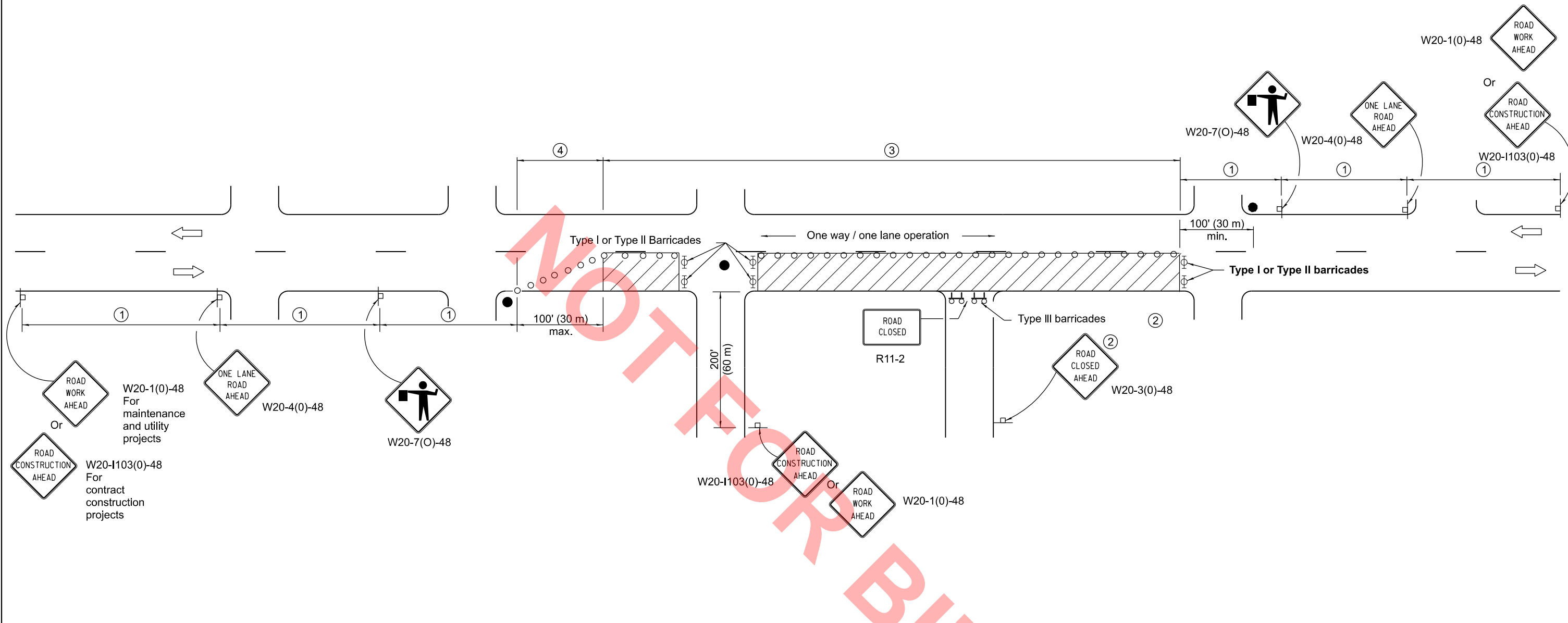

ROAD WORK AHEAD
Or
ROAD CONSTRUCTION AHEAD

W20-1(0)-48
For maintenance and utility projects

W20-1103(0)-48
For contract construction projects

ONE LANE ROAD AHEAD
W20-4(0)-48

W20-7(O)-48

ROAD CONSTRUCTION AHEAD
Or
ROAD WORK AHEAD

W20-1103(0)-48
Or
W20-1(0)-48

ROAD CLOSED
R11-2

ROAD CLOSED AHEAD
W20-3(0)-48

SIGN SPACING	
Posted Speed	Sign Spacing
55	500' (150 m)
50-45	350' (100 m)
<45	200' (60 m)

SYMBOLS

- Work area
- Cone, drum or barricade (not required for moving operations)
- Sign on portable or permanent support
- Flagger with traffic control sign
- Barricade or drum with flashing light
- Type III barricade with flashing lights

- ① Refer to SIGN SPACING TABLE for distances.
- ② For approved sideroad closures.
- ③ Cones at 25' (8 m) centers for 250' (75 m). Additional cones may be placed at 50' (15 m) centers. When drums or Type I or Type II barricades are used, the interval between devices may be doubled.
- ④ Cones, drums or barricades at 20' (6 m) centers.

GENERAL NOTES

This Standard is used where at any time, day or night, any vehicle, equipment, workers or their activities encroach on the pavement requiring the closure of one traffic lane in an urban area.

All dimensions are in inches (millimeters) unless otherwise shown.

DATE	REVISIONS
1-1-11	Revised flagger sign.
1-1-09	Switched units to English (metric). Corrected sign No.'s.

**URBAN LANE CLOSURE,
2L, 2W, UNDIVIDED**

STANDARD 701501-06

Illinois Department of Transportation

APPROVED January 1, 2011
Amelia A. Davis
ENGINEER OF SAFETY ENGINEERING

APPROVED January 1, 2011
Scott Schickel
ENGINEER OF DESIGN AND ENVIRONMENT

ISSUED 1-1-97

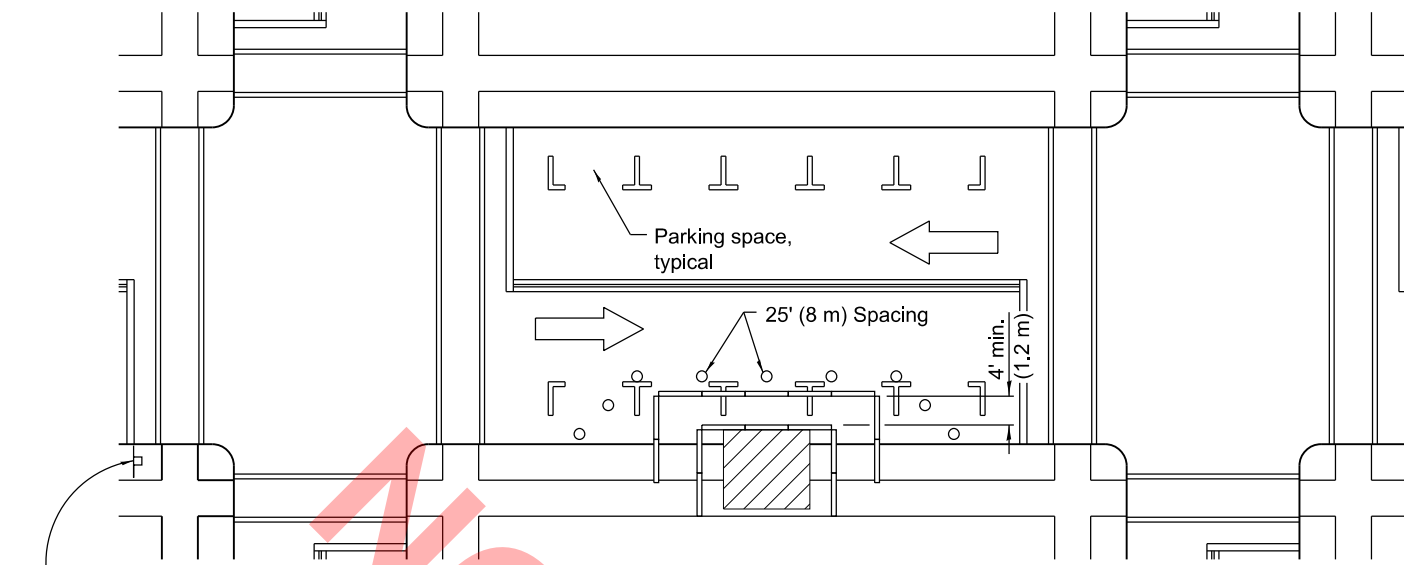

① ROAD CONSTRUCTION AHEAD
W20-I103(0)-48 for contract construction projects

Or
① ROAD WORK AHEAD
W20-1(0)-48 for maintenance and utility projects

SIDEWALK DIVERSION

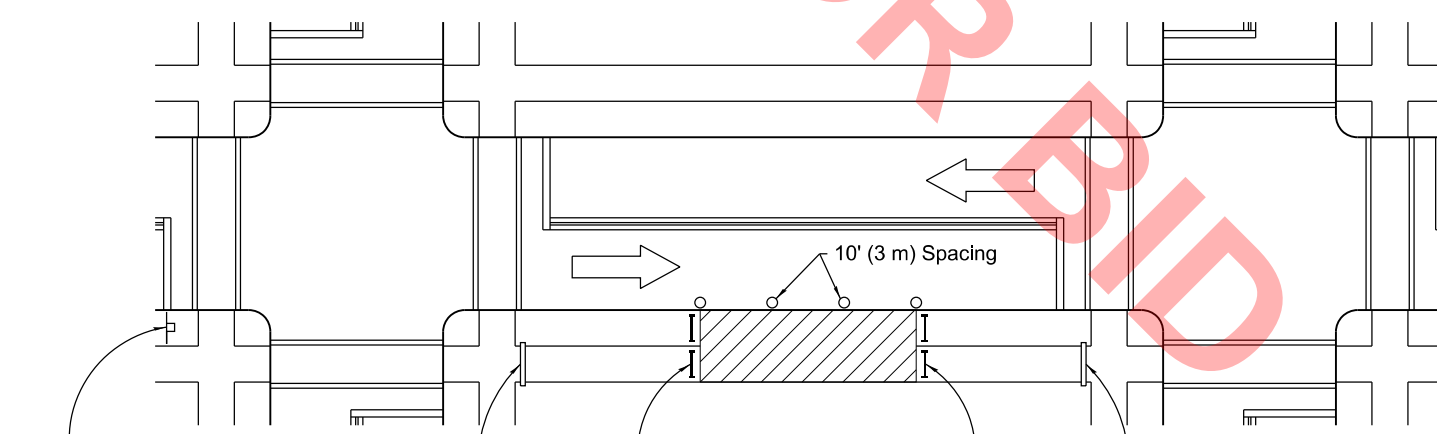

① ROAD CONSTRUCTION AHEAD
W20-I103(0)-48 for contract construction projects

Or
① ROAD WORK AHEAD
W20-1(0)-48 for maintenance and utility projects

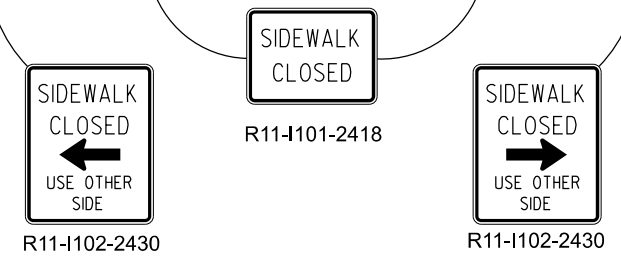

SIDEWALK CLOSURE

① Omit whenever duplicated by road work traffic control.

GENERAL NOTES

This Standard is used where, at any time, pedestrian traffic must be rerouted due to work being performed.

This Standard must be used in conjunction with other Traffic Control & Protection Standards when roadway traffic is affected.

Temporary facilities shall be detectable and accessible.

The temporary pedestrian facilities shall be provided on the same side of the closed facilities whenever possible.

The SIDEWALK CLOSED / USE OTHER SIDE sign shall be placed at the nearest crosswalk or intersection to each end of the closure. Where the closure occurs at a corner, the signs shall be erected on the corners across the street from the closure. The SIDEWALK CLOSED signs shall be used at the ends of the actual closures.

Type III barricades and R11-2-4830 signs shall be positioned as shown in "ROAD CLOSED TO ALL TRAFFIC" detail on Standard 701901.

All dimensions are in inches (millimeters) unless otherwise shown.

SYMBOLS

- Work area
- Sign on portable or permanent support
- Barricade or drum
- Cone, drum or barricade
- Type III barricade
- Detectable pedestrian channelizing barricade

Illinois Department of Transportation

APPROVED January 1, 2016
[Signature]
ENGINEER OF SAFETY ENGINEERING

APPROVED January 1, 2016
[Signature]
ENGINEER OF DESIGN AND ENVIRONMENT

ISSUED 1-1-97

DATE	REVISIONS
4-1-16	Omitted orange safety fence from standard as this is covered in the standard spec.
1-1-12	Added SIDEWALK DIVERSION.
	Modified appearance of plan views.
	Renamed Standard.

SIDEWALK, CORNER OR CROSSWALK CLOSURE

(Sheet 1 of 2)

STANDARD 701801-06

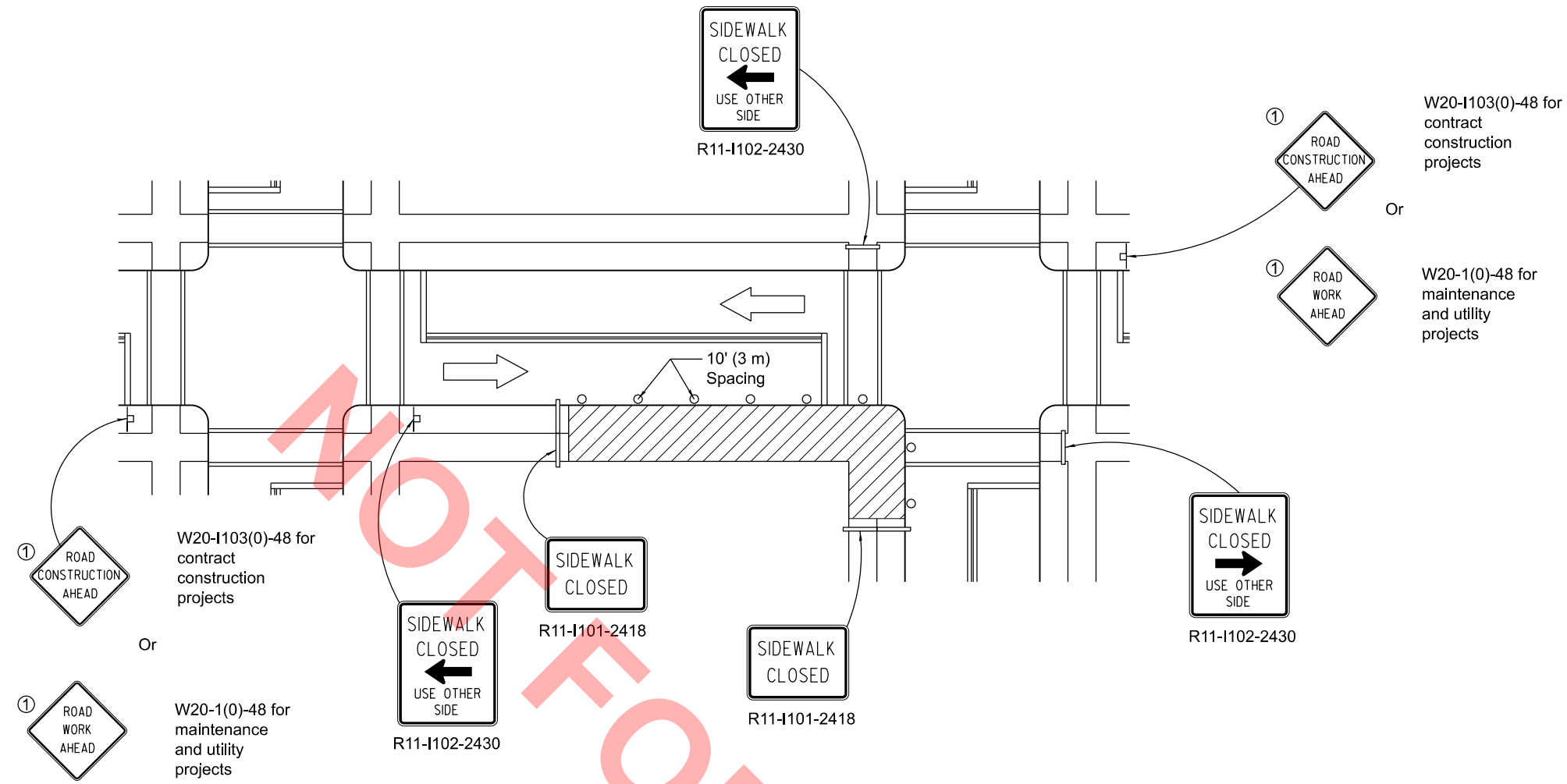

CORNER CLOSURE

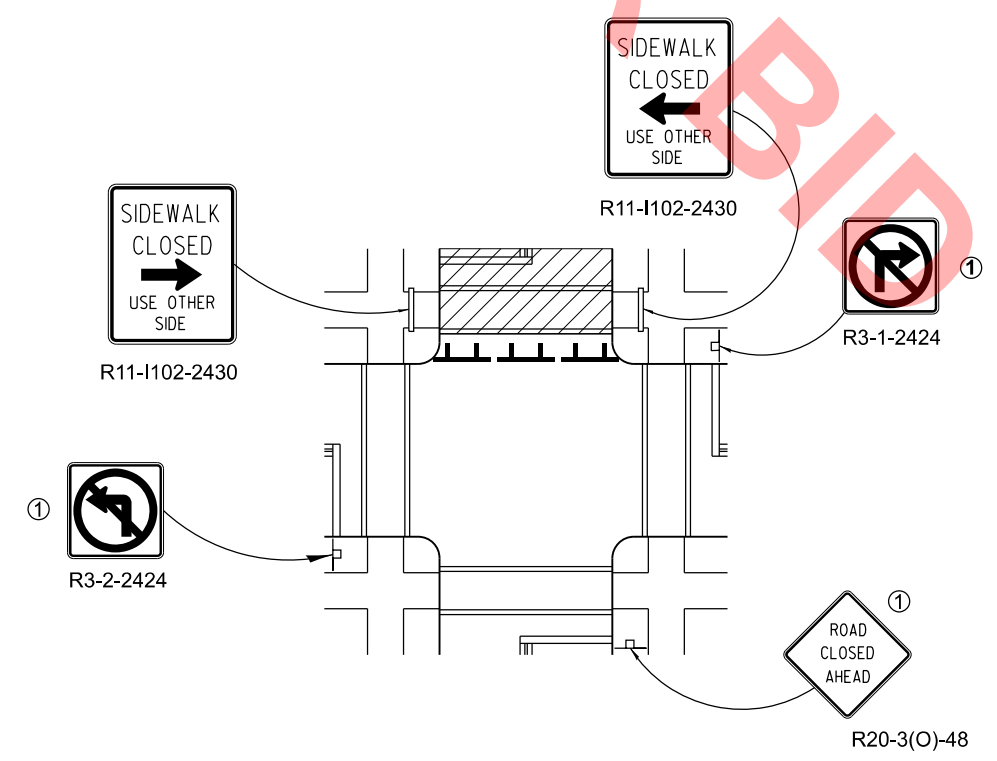

CROSSWALK CLOSURE

W20-I103(0)-48 for contract construction projects
Or
W20-1(0)-48 for maintenance and utility projects

SIDEWALK, CORNER OR CROSSWALK CLOSURE
(Sheet 2 of 2)
STANDARD 701801-06

Illinois Department of Transportation

APPROVED January 1, 2016
[Signature]
ENGINEER OF SAFETY ENGINEERING

APPROVED January 1, 2016
[Signature]
ENGINEER OF DESIGN AND ENVIRONMENT

ISSUED 1-1-97

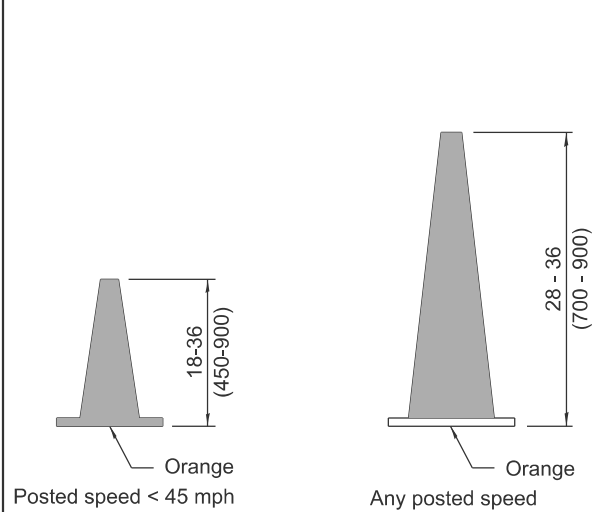

DAYTIME USE

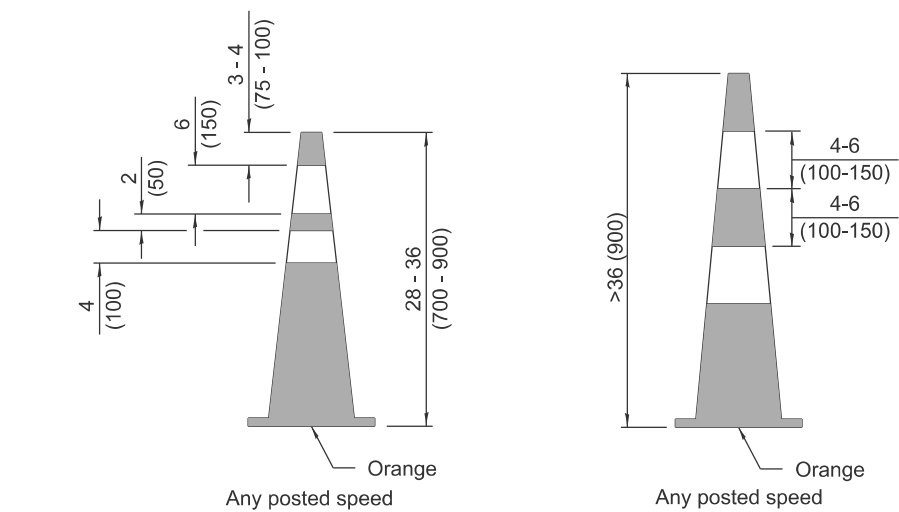

DAY OR NIGHTTIME USE

CONES

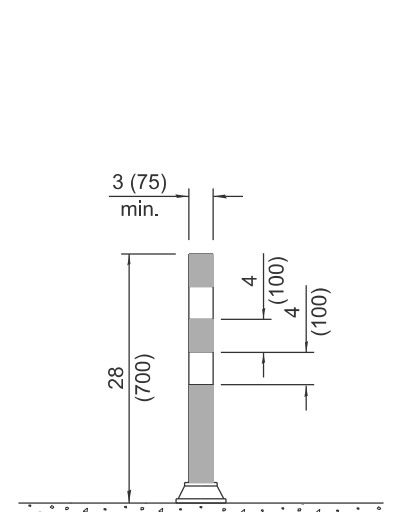

TUBULAR MARKER

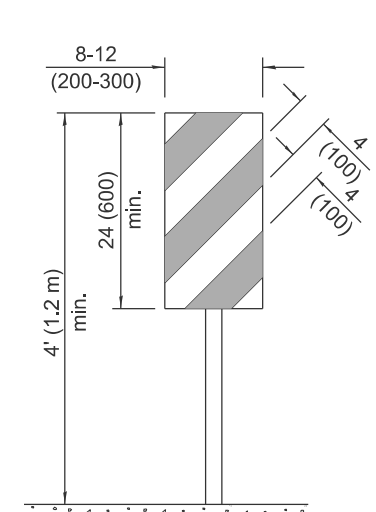

**VERTICAL PANEL
POST MOUNTED**

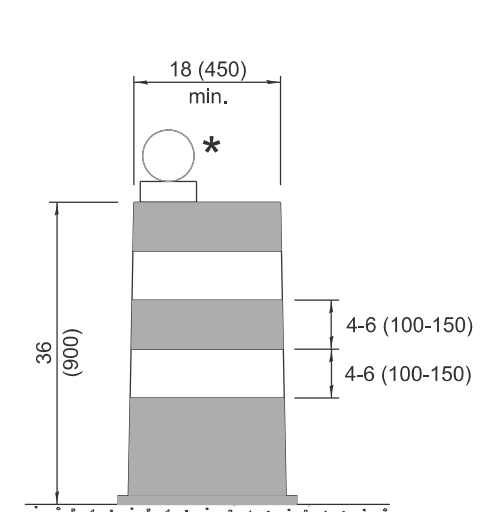

DRUM

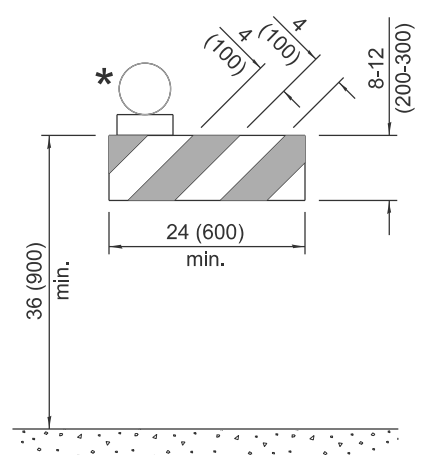

TYPE I BARRICADE

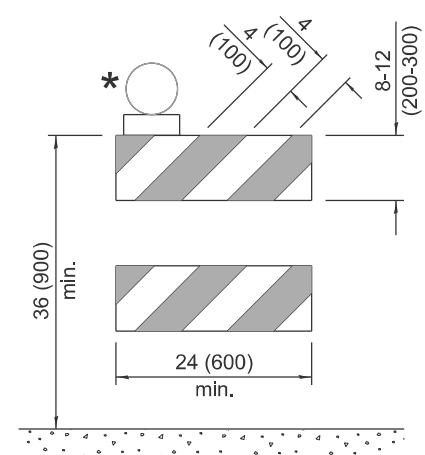

TYPE II BARRICADE

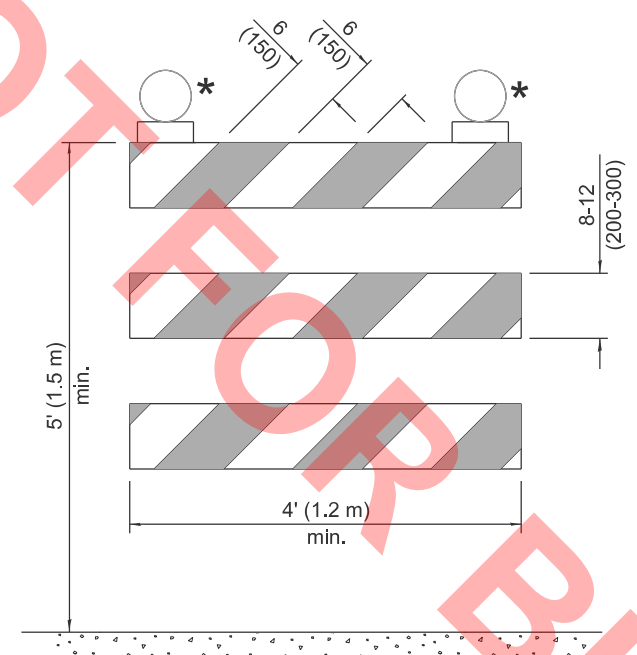

TYPE III BARRICADE

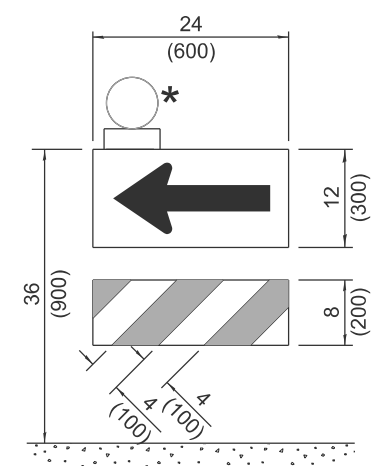

**DIRECTION INDICATOR
BARRICADE**

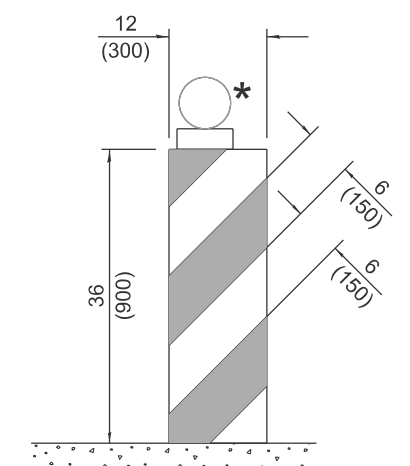

VERTICAL BARRICADE

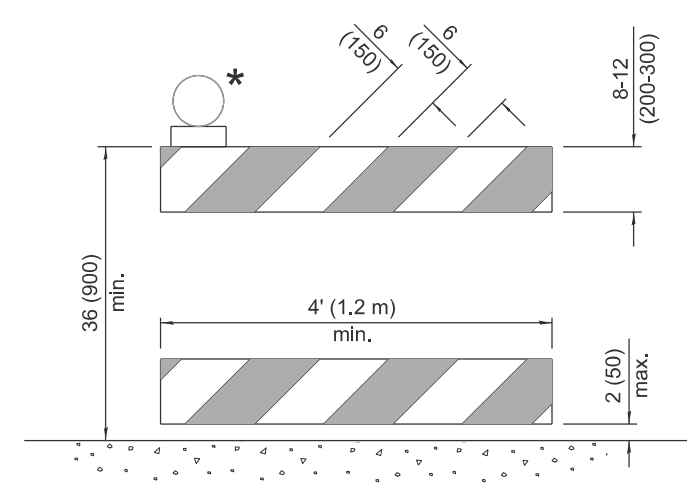

**DETECTABLE PEDESTRIAN
CHANNELIZING BARRICADE**

* Warning lights (if required)

GENERAL NOTES

All heights shown shall be measured above the pavement surface.

All dimensions are in inches (millimeters) unless otherwise shown.

Illinois Department of Transportation

APPROVED January 1, 2025

ENGINEER OF SAFETY PROG. AND ENGINEERING

APPROVED January 1, 2025

ENGINEER OF DESIGN AND ENVIRONMENT

ISSUED 1-1-13

DATE	REVISIONS
1-1-25	Updated Temporary Rumble Strip Detail (sht. 3).
1-1-24	Revised Type III Barricade notes (sht. 3) & moved warning light on post mounted signs to top center.

**TRAFFIC CONTROL
DEVICES**

(Sheet 1 of 3)

STANDARD 701901-10

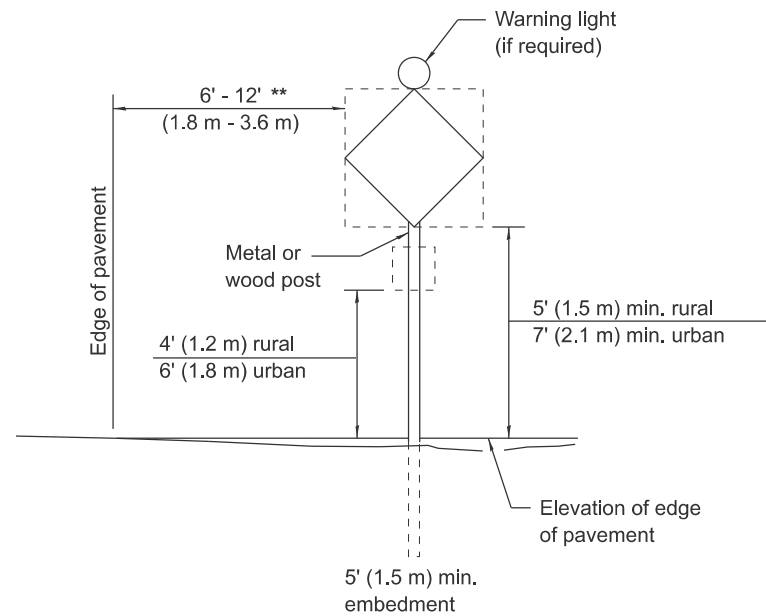

POST MOUNTED SIGNS

** When curb or paved shoulder are present this dimension shall be 24 (600) to the face of curb or 6' (1.8 m) to the outside edge of the paved shoulder.

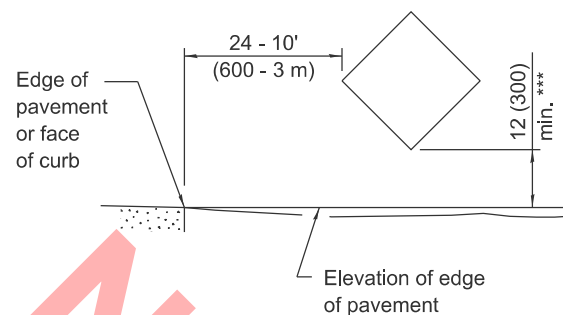

SIGNS ON TEMPORARY SUPPORTS

*** When work operations exceed four days, this dimension shall be 5' (1.5 m) min. If located behind other devices, the height shall be sufficient to be seen completely above the devices.

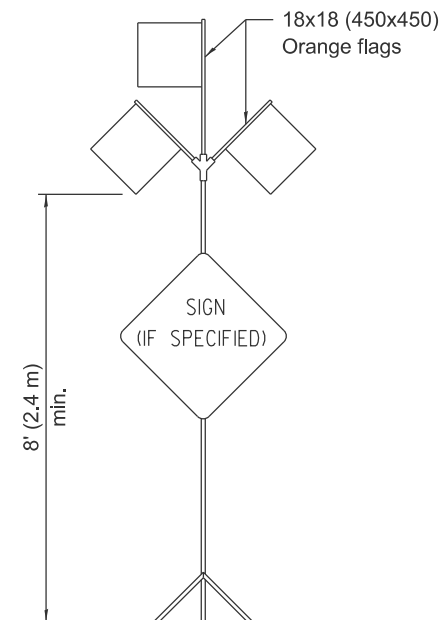

HIGH LEVEL WARNING DEVICE

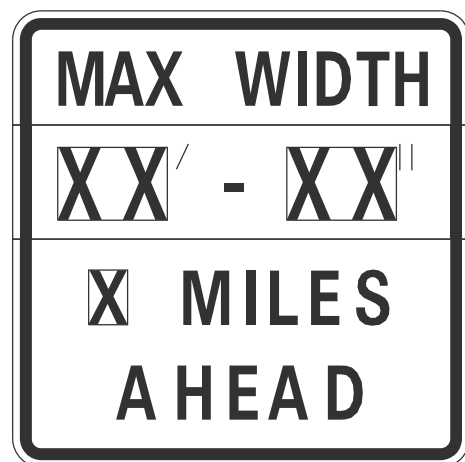

W12-1103-4848

WIDTH RESTRICTION SIGN

XX'-XX" width and X miles are variable.

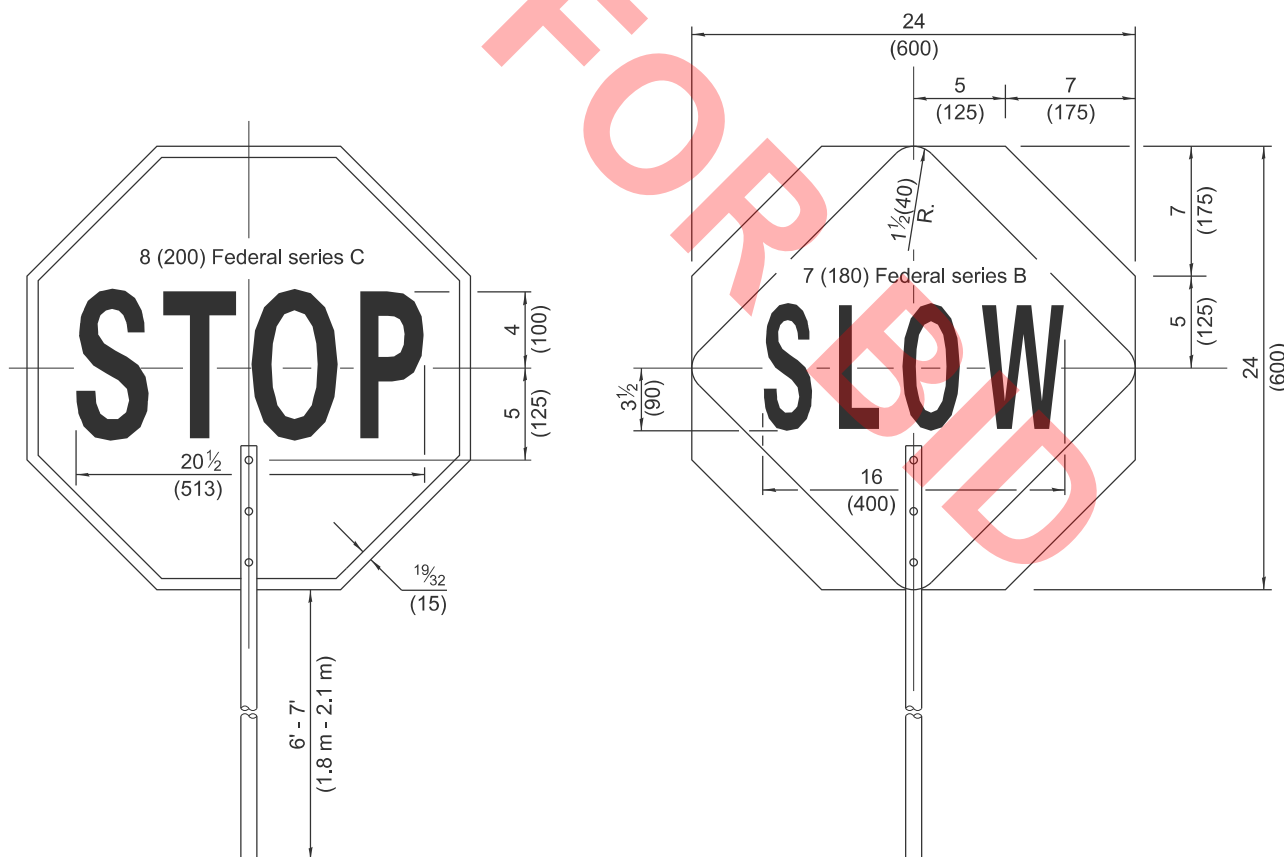

FRONT SIDE

REVERSE SIDE

FLAGGER TRAFFIC CONTROL SIGN



G20-1104(0)-6036



G20-1105(0)-6024

This signing is required for all projects 2 miles (3200 m) or more in length.

ROAD CONSTRUCTION NEXT X MILES sign shall be placed 500' (150 m) in advance of project limits.

END CONSTRUCTION sign shall be erected at the end of the job unless another job is within 2 miles (3200 m).

Dual sign displays shall be utilized on multi-lane highways.

WORK LIMIT SIGNING

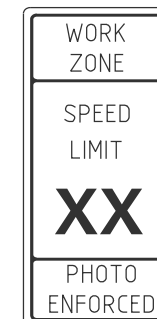

W21-1115(0)-3618

R2-1-3648

R10-1108p-3618 ****



R2-1106p-3618

Sign assembly as shown on Standards or as allowed by District Operations.

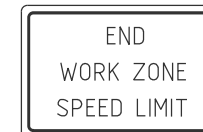

G20-1103-6036

This sign shall be used when the above sign assembly is used.

HIGHWAY CONSTRUCTION SPEED ZONE SIGNS

**** R10-1108p shall only be used along roadways under the jurisdiction of the State.

TRAFFIC CONTROL DEVICES

(Sheet 2 of 3)

STANDARD 701901-10

Illinois Department of Transportation

APPROVED January 1, 2025

ENGINEER OF SAFETY PROG. AND ENGINEERING

APPROVED January 1, 2025

ENGINEER OF DESIGN AND ENVIRONMENT

ISSUED 1-1-13

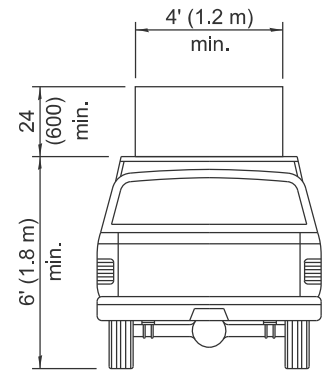

**TYPE A
ROOF
MOUNTED**

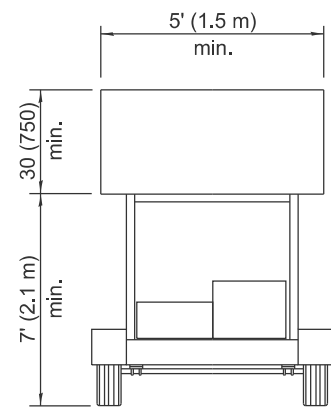

**TYPE B
ROOF OR TRAILER
MOUNTED**

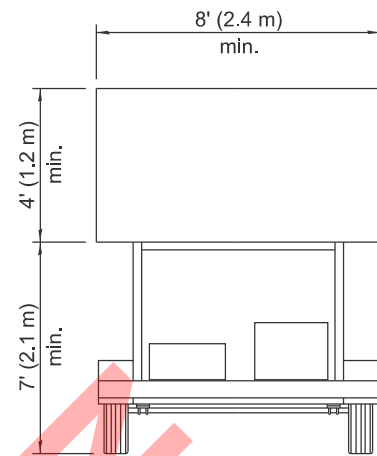

**TYPE C
TRAILER
MOUNTED**

ARROW BOARDS

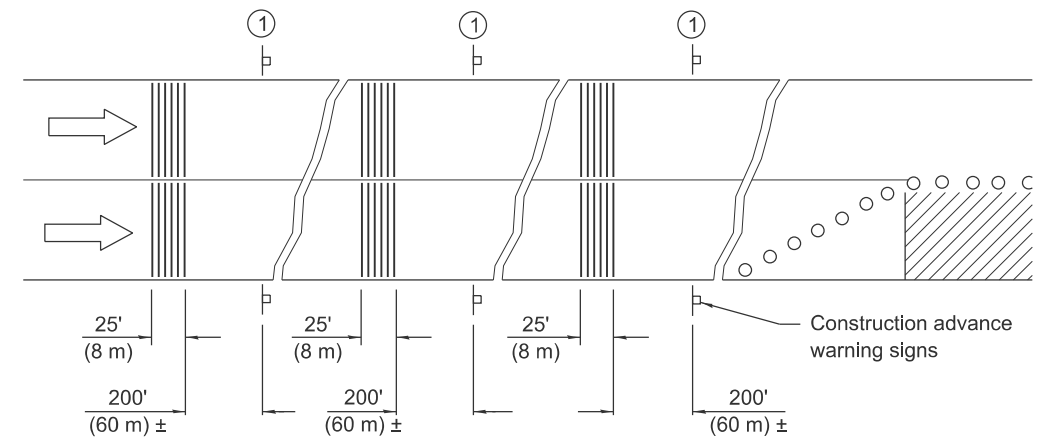

① This sign shall be omitted when median width is less than 10' (3 m).

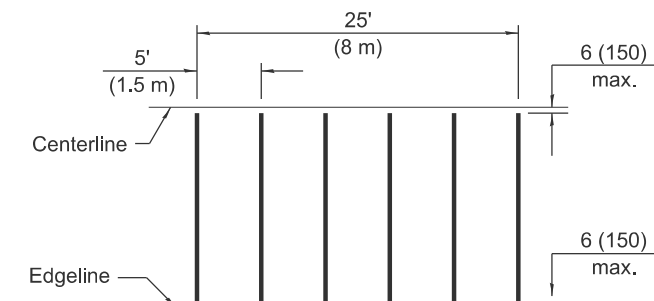

TYPICAL INSTALLATION

TEMPORARY RUMBLE STRIPS

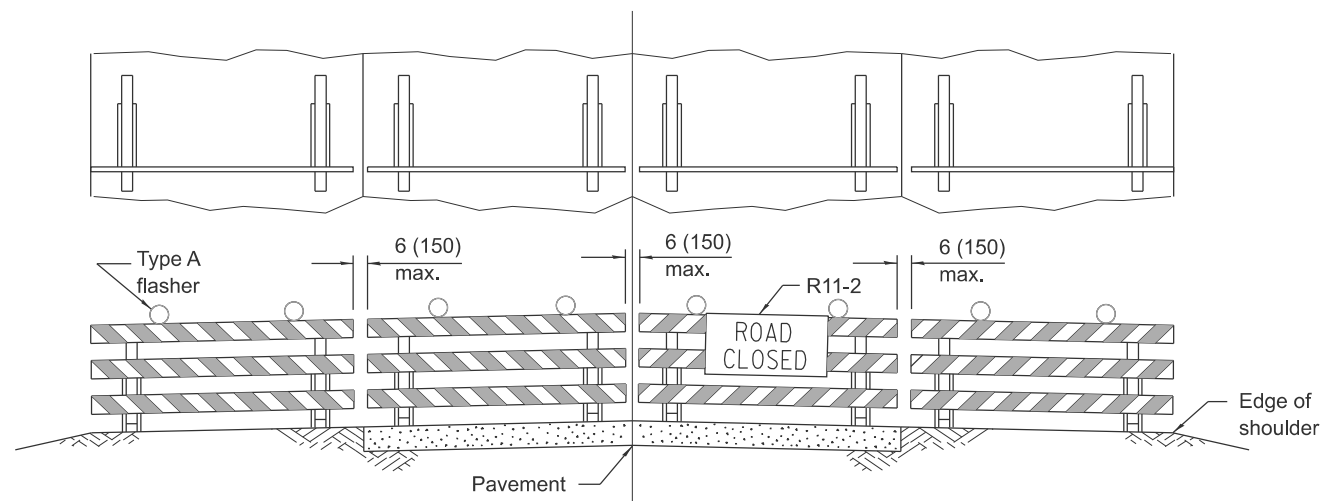

ROAD CLOSED TO ALL TRAFFIC

Reflectorized striping may be omitted on the back side of the barricades.

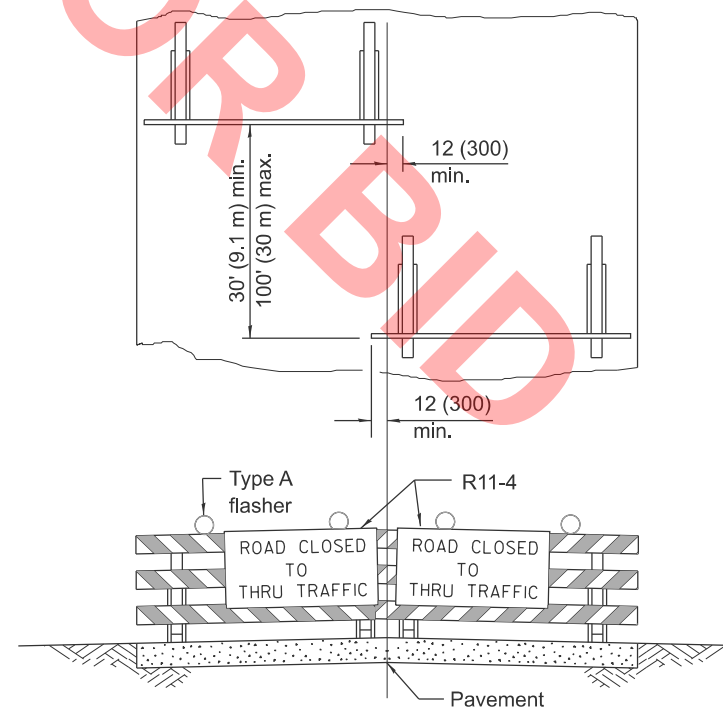

ROAD CLOSED TO THRU TRAFFIC

Reflectorized striping shall appear on both sides of the barricades.

**TYPICAL APPLICATIONS OF
TYPE III BARRICADES CLOSING A ROAD**

If a Type III barricade with an attached sign panel which meets NCHRP 350 or MASH is not available, the sign may be mounted on an NCHRP 350 or MASH temporary sign support directly in front of the barricade.

Illinois Department of Transportation

APPROVED January 1, 2025

ENGINEER OF SAFETY PROG. AND ENGINEERING

APPROVED January 1, 2025

ENGINEER OF DESIGN AND ENVIRONMENT

ISSUED 1-1-13

**TRAFFIC CONTROL
DEVICES**

(Sheet 3 of 3)

STANDARD 701901-10