



VILLAGE OF VILLA PARK

CONTRACT DOCUMENTS

FOR THE

**DCEO DRAINAGE IMPROVEMENT PROJECT
(VARIOUS LOCATIONS)**

ISSUED FOR BID JANUARY 10, 2025

PREPARED BY



**7325 JANES AVENUE
WOODRIDGE, ILLINOIS 60517**

NOT FOR BID

**ADVERTISEMENT FOR BIDS
VILLAGE OF VILLA PARK
FRIDAY, JANUARY 10, 2025**

PROJECT: DCEO DRAINAGE IMPROVEMENT PROJECT (VARIOUS LOCATIONS)

The base bid for this project consists of all work associated with stormwater and drainage improvements at the Ellsworth Ditch south of North Avenue and Ridge Road between Westmore Avenue and Roy Drive.

The project will also include two alternate bids for all work associated with stormwater and drainage improvements at Third Avenue & Vermont Street (Alternate 1), and 205 S. Yale Avenue (Alternate 2).

Project improvements include the installation of approximately 1,200 linear feet of storm sewer varying in size from 6" to 18", the installation of manholes, inlets and catch basins, ditch shaping and regading, pavement and driveway removal and replacement, earth excavation, combination concrete curb and gutter removal and installation, parkway restoration, sidewalk removal and replacement, and other related and incidental work.

A minimum of 28% of contract dollars shall be paid to BEP businesses with current and valid certification through the Illinois Commission on Equity and Inclusion's Business Enterprise Program (BEP). Failure to meet this requirement will be considered a breach of contract.

The Contractor must comply with all requirements set forth in the Illinois Department of Commerce & Economic Opportunity Grant Agreement for this project. Failure to comply with any of these requirements will be considered a breach of contract.

BID DEADLINE: Tuesday, January 28, 2025, 10:00 AM LOCAL TIME

The Village reserves the right to extend the Bid Deadline from this date and time to accept Bids submitted after the Bid Deadline, as the Village, in its sole discretion, determines is in the best interest of the Village.

NOTICE: Proposals for the **DCEO DRAINAGE IMPROVEMENT PROJECT (VARIOUS LOCATIONS)** will be received electronically by the Village of Villa Park, Illinois, through QuestCDN at <https://www.questcdn.com> under **QuestCDN Project #9482156** until the Bid Deadline. Immediately thereafter, the proposals will be opened and read aloud via Teams. Notwithstanding the foregoing, the Village reserves the right to defer, postpone, delay, or reschedule the Bid Opening for such time and to such date as the Village, in its sole discretion, determines is in the best interest of the Village. The Bid Opening Teams meeting may be accessed as follows:

Meeting ID: 278 053 801 187
Passcode: ve9uC9d2

Proposals shall be submitted in accordance with the Bidding Documents prepared by V3 Companies, 7325 Janes Avenue, Woodridge, IL 60517.

BIDDER QUALIFICATIONS: Bidders, in submitting a Bid, shall comply with all applicable federal, state, and local laws and requirements; shall provide documentation of that compliance in accordance with the requirements of the Bidding Documents and as requested by the Village; and, in submitting a Bid, Bidders affirm that they are qualified under all applicable laws and requirements to do so, and agree to be bound by the determination of the Village as to Bidder's compliance and qualifications.

REQUESTS FOR INFORMATION OR CLARIFICATION: All requests for information or clarification shall be submitted to the Village of Villa Park by email to engineering@invillapark.com. All responses that are provided to requests for information or clarification will be provided through QuestCDN at <https://www.questcdn.com> under **QuestCDN Project #9482156**.

The Village will accept requests for information or clarification submitted in accordance with the above requirements until **THURSDAY, JANUARY 23, 2025, 04:00 PM LOCAL TIME**. Requests for information or clarification received after such time will not be accepted and will receive no response.

ADDENDA: The Village reserves the right to issue Addenda modifying the Bidding Documents at any time prior to the Bid Deadline. The foregoing notwithstanding, the Village will make a reasonable effort to issue no addenda after **Friday, January 24, 2025, 04:00 PM LOCAL TIME**.

BID SECURITY: Bid Security in the amount of not less than ten percent (10%) of the Bid shall accompany each Bid in accordance with the Bidding Documents.

RIGHTS RESERVED: The Village will select the lowest, most responsible bidder. The Village reserves the right to reject any or all Bids, to waive any informalities or technicalities in bidding, and to accept the Bid which best serves the interests of the Village. The Village shall, in its sole discretion, determine what does or does not constitute an informality or technicality, and, in submitting a Bid, Bidder agrees to be bound by that determination.

The Village may make such investigations as it deems necessary to determine the ability of the Bidder to perform the Work, and the Bidder shall furnish to the Village all such information and data for this purpose as the Village may request. The Village reserves the right to reject any Bid if the evidence submitted by, or investigation of, such Bidder fails to satisfy the Village that such Bidder is properly qualified to carry out the obligations of the Agreement and to complete the Work contemplated therein.

BIDS TO REMAIN SUBJECT TO ACCEPTANCE: All bids shall remain subject to acceptance by the Village for a period of 90 calendar days from the date of the bid opening. The Village may extend the acceptance period by up to an additional

90 calendar days upon written notice to all bidders by the Village. The Village may, in its sole discretion, release any bid and return the bid bond prior to the end of the acceptance period.

CONTRACT SECURITY: The Bidder to whom a Contract is awarded shall be required to furnish both a Performance Bond and a Payment Bond acceptable to the Village for one-hundred percent (100%) of the Contract Price, in accordance with the requirements of the Contract Documents.

WAGE RATES: All applicable laws, ordinances, and the rules and regulations of all authorities having jurisdiction over construction of the PROJECT shall apply to the contract throughout.

The Contractor shall not pay less than the DuPage County Prevailing Wage Rates (Illinois Department of Labor) to all laborers, workmen, and mechanics performing work under this contract, and shall comply with the requirements of the Prevailing Wage Act (820 ILCS 130/1-12).

BIDDING DOCUMENTS: The Bidding Documents may be obtained from QuestCDN at <https://www.questcdn.com> under **QuestCDN Project #9482156** for a non-refundable fee of forty-two dollars (\$42.00). An active QuestCDN account and login are required. Questions or issues regarding the QuestCDN platform shall be directed to QuestCDN by phone at 952-233-1632 or by email at info@questcdn.com. Hard copies of bidding documents will not be made available. An electronic "Not for Bid" version of the bidding documents in Portable Document Format (PDF) will be available for download on the project page on the Village of Villa Park's website at <https://www.invillapark.com>. This version of the bidding documents is for informational purposes only and may not be used for the preparation or submittal of a bid.

PUBLISHED BY AUTHORITY OF THE VILLAGE OF VILLA PARK, COUNTY OF DUPAGE, STATE OF ILLINOIS.

COVER SHEET

Proposal Submitted By:

Contractor's Name

Contractor's Address

City

State

Zip Code

STATE OF ILLINOIS

Local Public Agency

Village of Villa Park

County

DuPage

Section Number

N/A

Route(s) (Street/Road Name)

Various

Type of Funds

DCEO

Proposal Only Proposal and Plans Proposal only, plans are separate

Submitted/Approved

For Local Public Agency:

For a County and Road District Project

Submitted/Approved

Highway Commissioner Signature & Date

Submitted/Approved

County Engineer/Superintendent of Highways Signature & Date

For a Municipal Project

Submitted/Approved/Passed

Signature & Date

Official Title

Department of Transportation

Released for bid based on limited review

Regional Engineer Signature & Date

Note: All proposal documents, including Proposal Guaranty Checks or Proposal Bid Bonds, should be stapled together to prevent loss when bids are processed.

Local Public Agency	County	Section Number	Route(s) (Street/Road Name)
Village of Villa Park	DuPage	N/A	Various

NOTICE TO BIDDERS

Sealed proposals for the project described below will be received at the office of Public Works Department

11 West Home Avenue, Villa Park, IL 60181	until	10:00AM	on	01/28/25
Address		Time		Date

Sealed proposals will be opened and read publicly at the office of Public Works Department

11 West Home Avenue, Villa Park, IL 60181	at	10:00 AM	on	01/28/25
Address		Time		Date

DESCRIPTION OF WORK

Location	Project Length
Various	0.28 mi

Proposed Improvement
 Storm sewer installation; pavement/curb&gutter/driveway/sidewalk removal and replacement; drainage improvements; ditch shaping and grading; pavement patching; parkway restoration

1. Plans and proposal forms will be available in the office of
 Electronically at WWW.QUESTCDN.COM or Village of Villa Park Public Works Department, 11 West Home Ave, Villa Park, IL 60618

2. Prequalification
 If checked, the 2 apparent as read low bidders must file within 24 hours after the letting an "Affidavit of Availability" (Form BC 57) in triplicate, showing all uncompleted contracts awarded to them and all low bids pending award for Federal, State, County, Municipal and private work. One original shall be filed with the Awarding Authority and two originals with the IDOT District Office.
3. The Awarding Authority reserves the right to waive technicalities and to reject any or all proposals as provided in BLRS Special Provision for Bidding Requirements and Conditions for Contract Proposals.
4. The following BLR Forms shall be returned by the bidder to the Awarding Authority:
 - a. Local Public Agency Formal Contract Proposal (BLR 12200)
 - b. Schedule of Prices (BLR 12201)
 - c. Proposal Bid Bond (BLR 12230) (if applicable)
 - d. Apprenticeship or Training Program Certification (BLR 12325) (do not use for project with Federal funds.)
 - e. Affidavit of Illinois Business Office (BLR 12326) (do not use for project with Federal funds)
5. The quantities appearing in the bid schedule are approximate and are prepared for the comparison of bids. Payment to the Contractor will be made only for the actual quantities of work performed and accepted or materials furnished according to the contract. The scheduled quantities of work to be done and materials to be furnished may be increased, decreased or omitted as hereinafter provided.
6. Submission of a bid shall be conclusive assurance and warranty the bidder has examined the plans and understands all requirements for the performance of work. The bidder will be responsible for all errors in the proposal resulting from failure or neglect to conduct an in depth examination. The Awarding Authority will, in no case, be responsible for any costs, expenses, losses or changes in anticipated profits resulting from such failure or neglect of the bidder.
7. The bidder shall take no advantage of any error or omission in the proposal and advertised contract.
8. If a special envelope is supplied by the Awarding Authority, each proposal should be submitted in that envelope furnished by the Awarding Agency and the blank spaces on the envelope shall be filled in correctly to clearly indicate its contents. When an envelope other than the special one furnished by the Awarding Authority is used, it shall be marked to clearly indicate its contents. When sent by mail, the sealed proposal shall be addressed to the Awarding Authority at the address and in care of the official in whose office the bids are to be received. All proposals shall be filed prior to the time and at the place specified in the Notice to Bidders. Proposals received after the time specified will be returned to the bidder unopened.
9. Permission will be given to a bidder to withdraw a proposal if the bidder makes the request in writing or in person before the time for opening proposals.

Local Public Agency	County	Section Number	Route(s) (Street/Road Name)
Village of Villa Park	DuPage	N/A	Various

PROPOSAL

1. Proposal of _____ Contractor's Name _____

Contractor's Address _____

2. The plans for the proposed work are those prepared by V3 Companies and approved by the Department of Transportation on N/A.

3. The specifications referred to herein are those prepared by the Department of Transportation and designated as "Standard Specifications for Road and Bridge Construction" and the " Supplemental Specifications and Recurring Special Provisions" thereto, adopted and in effect on the date of invitation for bids.

4. The undersigned agrees to accept, as part of the contract, the applicable Special Provisions indicated on the "Check Sheet for Recurring Special Provisions" contained in this proposal.

5. The undersigned agrees to complete the work within _____ working days or by _____ unless additional time is granted in accordance with the specifications.

6. The successful bidder at the time of execution of the contract _____ be required to deposit a contract bond for the full amount of the award. When a contract bond is not required, the proposal guaranty check will be held in lieu thereof. If this proposal is accepted and the undersigned fails to execute a contract and contract bond as required, it is hereby agreed that the Bid Bond of check shall be forfeited to the Awarding Authority.

7. Each pay item should have a unit price and a total price. If no total price is shown or if there is a discrepancy between the products of the unit price multiplied by the quantity, the unit price shall govern. If a unit price is omitted, the total price will be divided by the quantity in order to establish a unit price. A bid may be declared unacceptable if neither a unit price nor a total price is shown.

8. The undersigned submits herewith the schedule of prices on BLR 12201 covering the work to be performed under this contract.

9. The undersigned further agrees that if awarded the contract for the sections contained in the combinations on BLR 12201, the work shall be in accordance with the requirements of each individual proposal for the multiple bid specified in the Schedule for Multiple Bids below.

10. A proposal guaranty in the proper amount, as specified in BLRS Special Provision for Bidding Requirements and Conditions for Contract Proposals, will be required. Bid Bonds will be allowed as a proposal guaranty. Accompanying this proposal is either a bid bond, if allowed, on Department form BLR 12230 or a proposal guaranty check, complying with the specifications, made payable to: Village Treasurer of Villa Park.

The amount of the check is _____ (_____).

Attach Cashier's Check or Certified Check Here

In the event that one proposal guaranty check is intended to cover two or more bid proposals, the amount must be equal to the sum of the proposal guaranties which would be required for each individual bid proposal. If the proposal guaranty check is placed in another bid proposal, state below where it may be found.

The proposal guaranty check will be found in the bid proposal for: Section Number _____.

Local Public Agency	County	Section Number	Route(s) (Street/Road Name)
Village of Villa Park	DuPage	N/A	Various

CONTRACTOR CERTIFICATIONS

The certifications hereinafter made by the bidder are each a material representation of fact upon which reliance is placed should the Department enter into the contract with the bidder.

- Debt Delinquency.** The bidder or contractor or subcontractor, respectively, certifies that it is not delinquent in the payment of any tax administered by the Department of Revenue unless the individual or other entity is contesting, in accordance with the procedure established by the appropriate Revenue Act, its liability for the tax or the amount of the tax. Making a false statement voids the contract and allows the Department to recover all amounts paid to the individual or entity under the contract in a civil action.
- Bid-Rigging or Bid Rotating.** The bidder or contractor or subcontractor, respectively, certifies that it is not barred from contracting with the Department by reason of a violation of either 720 ILCS 5/33E-3 or 720 ILCS 5/33E-4.

A violation of section 33E-3 would be represented by a conviction of the crime of bid-rigging which, in addition to Class 3 felony sentencing, provides that any person convicted of this offense, or any similar offense of any state or the United States which contains the same elements as this offense shall be barred for 5 years from the date of conviction from contracting with any unit of State or local government. No corporation shall be barred from contracting with any unit of State or local government as a result of a conviction under this Section of any employee or agent of such corporation if the employee so convicted is no longer employed by the corporation: (1) it has been finally adjudicated not guilty or (2) if it demonstrates to the governmental entity with which it seeks to contract that entity finds that the commission of the offense was neither authorized, requested, commanded, nor performed by a director, officer or a high managerial agent on behalf of the corporation.

A violation of Section 33E-4 would be represented by a conviction of the crime of bid-rotating which, in addition to Class 2 felony sentencing, provides that any person convicted of this offense or any similar offense of any state or the United States which contains the same elements as this offense shall be permanently barred from contracting with any unit of State of Local government. No corporation shall be barred from contracting with any unit of State or Local government as a result of a conviction under this Section of any employee or agent of such corporation if the employee so convicted is no longer employed by the corporation and: (1) it has been finally adjudicated not guilty or (2) if it demonstrates to the governmental entity with which it seeks to contract and that entity finds that the commission of the offense was neither authorized, requested, commanded, nor performed by a director, officer or a high managerial agent on behalf of the corporation.

- Bribery.** The bidder or contractor or subcontractor, respectively, certifies that, it has not been convicted of bribery or attempting to bribe an officer or employee of the State of Illinois or any unit of local government, nor has the firm made an admission of guilt of such conduct which is a matter or record, nor has an official, agent, or employee of the firm committed bribery or attempted bribery on behalf of the firm and pursuant to the direction or authorization of a responsible official of the firm.
- Interim Suspension or Suspension.** The bidder or contractor or subcontractor, respectively, certifies that it is not currently under a suspension as defined in Subpart I of Title 44 Subtitle A Chapter III Part 6 of the Illinois Administrative code. Furthermore, if suspended prior to completion of this work, the contract or contracts executed for the completion of this work may be canceled.

Local Public Agency	County	Section Number	Route(s) (Street/Road Name)
Village of Villa Park	DuPage	N/A	Various

SIGNATURES

(If an individual)

Bidder Signature & Date

Business Address

City	State	Zip Code
<input type="text"/>	<input type="text"/>	<input type="text"/>

(If a partnership)

Firm Name

Signature & Date

Title

Business Address

City	State	Zip Code
<input type="text"/>	<input type="text"/>	<input type="text"/>

Insert the Names and Addresses of all Partners

(If a corporation)

Corporate Name

Signature & Date

Title

Business Address

City	State	Zip Code
<input type="text"/>	<input type="text"/>	<input type="text"/>

Insert Names of Officers

President

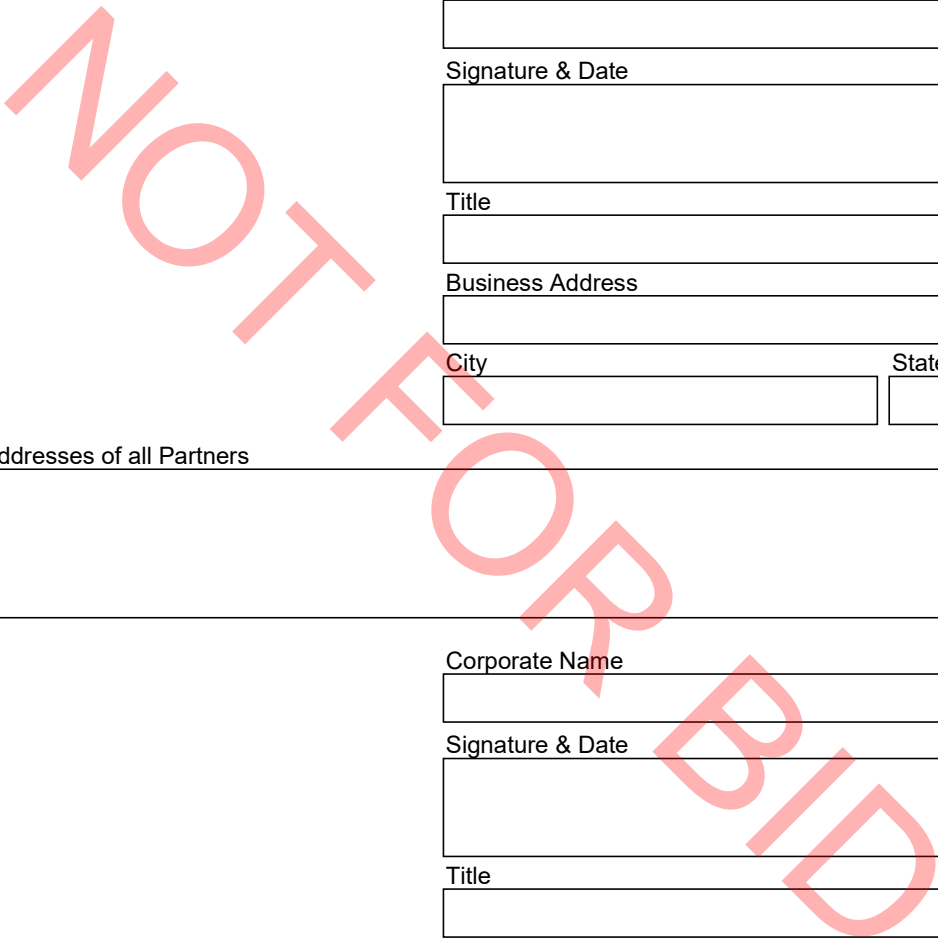

Attest:

Secretary

Secretary

Treasurer

NOT FOR BID

RETURN WITH BID



SCHEDULE OF PRICES

Contractor's Name:

Local Public Agency: **Village of Villa Park**

County: **DuPage**

Section: **N/A**

Route: **Various**

For Information Only
Use QuestCDN Schedule of Prices

Schedule for Multiple Bids

Combination Letter	Sections included in Combinations	Total

Schedule for Single Bid

(For complete information covering these items, see plans and specifications)

Bidder's proposal for making **BASE BID** improvements

Item No.	Items	Unit	Quantity	Unit Price	Total
1	EARTH EXCAVATION	CU YD	258		
2	REMOVAL AND DISPOSAL OF UNSUITABLE MATERIAL	CU YD	229		
3	TRENCH BACKFILL	CU YD	1,004		
4	TOPSOIL FURNISH AND PLACE, 4"	SQ YD	968		
5	GRADING AND SHAPING DITCHES	FOOT	407		
6	SEEDING, CLASS 4A	ACRE	0.20		
7	EROSION CONTROL BLANKET	SQ YD	968		
8	INLET AND PIPE PROTECTION	EACH	1		
9	INLET FILTERS	EACH	7		
10	STONE RIPRAP, CLASS A3	SQ YD	46		
11	FILTER FABRIC	SQ YD	354		
12	AGGREGATE BASE COURSE, TYPE B 6"	SQ YD	93		
13	PORTLAND CEMENT CONCRETE SIDEWALK 5 INCH	SQ FT	1,580		
14	DETECTABLE WARNINGS	SQ FT	10,000		
15	DRIVEWAY PAVEMENT REMOVAL	SQ YD	93		
16	SIDEWALK REMOVAL	SQ FT	1,580		
17	STORM SEWER REMOVAL 18"	FOOT	49		
18	MANHOLES TO BE RECONSTRUCTED	EACH	1		
19	INLETS TO BE RECONSTRUCTED	EACH	2		
20	ABANDON AND FILL EXISTING STORM SEWER	FOOT	40		
21	HOT-MIX ASPHALT DRIVEWAY PAVEMENT, 4"	SQ YD	93		
22	12" X 12" NDS YARD DRAIN WITH GRATE	EACH	3		
23	ROUNDED RIVER ROCK (1"-1.5" NOMINAL DIA.), 4" DEPTH	SQ YD	220		
24	AGGREGATE BASE (CA-1), 8" DEPTH	SQ YD	220		
25	CLASS D PATCHES, SPECIAL	SQ YD	433		
26	CONCRETE CURB AND GUTTER REMOVAL AND REPLACEMENT	FOOT	286		
27	PARKWAY RESTORATION	SQ YD	394		
28	CATCH BASIN, TYPE C, 2' DIAMETER	EACH	1		

For Information Only
Use QuestCDN Schedule of Prices
RETURN WITH BID

Item No.	Items	Unit	Quantity	Unit Price	Total
29	CATCH BASIN, TYPE A, 4' DIAMETER	EACH	3		
30	MANHOLE, TYPE A, 4' DIAMETER	EACH	3		
31	FRAMES AND LIDS, TYPE 1	EACH	4		
32	FRAMES AND GRATES, TYPE 11	EACH	3		
33	STORM SEWERS, PVC, 6" (SDR 26, ASTM D-2241)	FOOT	35		
34	STORM SEWERS, PVC, 15" (SDR 26, ASTM D-2241)	FOOT	158		
35	STORM SEWERS, RCP, 12"	FOOT	688		
36	CONCRETE BULKHEAD	EACH	2		
37	TRAFFIC CONTROL AND PROTECTION (SPECIAL)	LSUM	2		
38	CONSTRUCTION LAYOUT	LSUM	2		
39	PRE-CONSTRUCTION VIDEO RECORDING	LSUM	2		
40	WATER USAGE CREDIT	TGAL	30	\$8.85	\$265.50
41	WATER USAGE DEDUCTION	TGAL	30	(\$8.85)	(\$265.50)
42	CONTINGENCY ALLOWANCE	DOLLAR	30,000	\$1.00	\$30,000.00
END OF SCHEDULE OF PRICES				BASE BID TOTAL=	

1. Each pay item should have a unit price and a total price.
2. If no total price is shown or if there is a discrepancy between the product of the unit price multiplied by the quantity, the unit price shall govern.
3. If a unit price is omitted, the total price will be divided by the quantity in order to establish a unit price.
4. A bid may be declared unacceptable if neither a unit price or total price is shown.

RETURN WITH BID



SCHEDULE OF PRICES

Contractor's Name:

Local Public Agency: **Village of Villa Park**

County: **DuPage**

Section: **N/A**

Route: **Various**

For Information Only
Use QuestCDN Schedule of Prices
Schedule for Multiple Bids

Combination Letter	Sections included in Combinations	Total

Schedule for Single Bid

(For complete information covering these items, see plans and specifications)

Bidder's proposal for making **ALTERNATE 1** improvements

Item No.	Items	Unit	Quantity	Unit Price	Total
A1.3	TRENCH BACKFILL	CU YD	76		
A1.9	INLET FILTERS	EACH	6		
A1.12	AGGREGATE BASE COURSE, TYPE B 6"	SQ YD	25		
A1.13	PORTLAND CEMENT CONCRETE SIDEWALK 5 INCH	SQ FT	180		
A1.14	DETECTABLE WARNINGS	SQ FT	20		
A1.15	DRIVEWAY PAVEMENT REMOVAL	SQ YD	25		
A1.16	SIDEWALK REMOVAL	SQ FT	180		
A1.21	HOT-MIX ASPHALT DRIVEWAY PAVEMENT, 4"	SQ YD	25		
A1.22	12" X 12" NDS YARD DRAIN WITH GRATE	EACH	3		
A1.26	CONCRETE CURB AND GUTTER REMOVAL AND REPLACEMENT	FOOT	44		
A1.27	PARKWAY RESTORATION	SQ YD	136		
A1.28	CATCH BASIN, TYPE C, 2' DIAMETER	EACH	1		
A1.32	FRAMES AND GRATES, TYPE 11	EACH	1		
A1.33	STORM SEWERS, PVC, 6" (SDR 26, ASTM D-2241)	FOOT	98		
A1.37	TRAFFIC CONTROL AND PROTECTION (SPECIAL)	LSUM	1		
A1.38	CONSTRUCTION LAYOUT	LSUM	1		
A1.39	PRE-CONSTRUCTION VIDEO RECORDING	LSUM	1		
A1.40	WATER USAGE CREDIT	TGAL	5	\$8.85	\$44.25
A1.41	WATER USAGE DEDUCTION	TGAL	5	(\$8.85)	(\$44.25)
A1.42	CONTINGENCY ALLOWANCE	DOLLAR	5,000	\$1.00	\$5,000.00
A1.44	CLASS C PATCHES, SPECIAL	SQ YD	20		
A1.48	STORM SEWERS, PVC, 12" (SDR 26, ASTM D-2241)	FOOT	38		
END OF SCHEDULE OF PRICES				ALTERNATE 1 TOTAL=	

1. Each pay item should have a unit price and a total price.
2. If no total price is shown or if there is a discrepancy between the product of the unit price multiplied by the quantity, the unit price shall govern.
3. If a unit price is omitted, the total price will be divided by the quantity in order to establish a unit price.
4. A bid may be declared unacceptable if neither a unit price or total price is shown.

RETURN WITH BID



SCHEDULE OF PRICES

Contractor's Name:

Local Public Agency: **Village of Villa Park**

County: **DuPage**

Section: **N/A**

Route: **Various**

For Information Only
Use QuestCDN Schedule of Prices

Schedule for Multiple Bids

Combination Letter	Sections included in Combinations	Total

Schedule for Single Bid

(For complete information covering these items, see plans and specifications)

Bidder's proposal for making **ALTERNATE 2** improvements

Item No.	Items	Unit	Quantity	Unit Price	Total
A2.3	TRENCH BACKFILL	CU YD	50		
A2.9	INLET FILTERS	EACH	4		
A2.18	MANHOLES TO BE RECONSTRUCTED	EACH	1		
A2.25	CLASS D PATCHES, SPECIAL	SQ YD	107		
A2.26	CONCRETE CURB AND GUTTER REMOVAL AND REPLACEMENT	FOOT	13		
A2.27	PARKWAY RESTORATION	SQ YD	18		
A2.28	CATCH BASIN, TYPE C, 2' DIAMETER	EACH	1		
A2.31	FRAMES AND LIDS, TYPE 1	EACH	1		
A2.32	FRAMES AND GRATES, TYPE 11	EACH	1		
A2.37	TRAFFIC CONTROL AND PROTECTION (SPECIAL)	LSUM	1		
A2.38	CONSTRUCTION LAYOUT	LSUM	1		
A2.39	PRE-CONSTRUCTION VIDEO RECORDING	LSUM	1		
A2.40	WATER USAGE CREDIT	TGAL	5	\$8.85	\$44.25
A2.41	WATER USAGE DEDUCTION	TGAL	5	(\$8.85)	(\$44.25)
A2.42	CONTINGENCY ALLOWANCE	DOLLAR	5,000	\$1.00	\$5,000.00
A2.43	CLEANOUTS	EACH	1		
A2.45	INLET, TYPE A, 2' DIAMETER	EACH	1		
A2.46	STORM SEWERS, PVC, 8" (SDR 26, ASTM D-2241)	FOOT	10		
A2.47	STORM SEWERS, PVC, 10" (SDR 26, ASTM D-2241)	FOOT	8		
A2.48	STORM SEWERS, PVC, 12" (SDR 26, ASTM D-2241)	FOOT	204		
END OF SCHEDULE OF PRICES				ALTERNATE 2 TOTAL=	

1. Each pay item should have a unit price and a total price.
2. If no total price is shown or if there is a discrepancy between the product of the unit price multiplied by the quantity, the unit price shall govern.
3. If a unit price is omitted, the total price will be divided by the quantity in order to establish a unit price.
4. A bid may be declared unacceptable if neither a unit price or total price is shown.

**Local Public Agency
Proposal Bid Bond**

Local Public Agency Village of Villa Park	County DuPage	Section Number N/A
--	------------------	-----------------------

WE, _____ as PRINCIPAL, and _____ as SURETY, are held jointly, severally and firmly bound unto the above Local Public Agency (hereafter referred to as "LPA") in the penal sum of 10% of the total bid price, or for the amount specified in the proposal documents in effect on the date of invitation for bids, whichever is the lesser sum. We bind ourselves, our heirs, executors, administrators, successors, and assigns, jointly pay to the LPA this sum under the conditions of this instrument.

WHEREAS THE CONDITION OF THE FOREGOING OBLIGATION IS SUCH that, the said PRINCIPAL is submitting a written proposal to the LPA acting through its awarding authority for the construction of the work designated as the above section.

THEREFORE if the proposal is accepted and a contract awarded to the PRINCIPAL by the LPA for the above designated section and the PRINCIPAL shall within fifteen (15) days after award enter into a formal contract, furnish surety guaranteeing the faithful performance of the work, and furnish evidence of the required insurance coverage, all as provided in the "Standard Specifications for Road and Bridge Construction" and applicable Supplemental Specifications, then this obligation shall become void; otherwise it shall remain in full force and effect.

IN THE EVENT the LPA determines the PRINCIPAL has failed to enter into a formal contract in compliance with any requirements set forth in the preceding paragraph, then the LPA acting through its awarding authority shall immediately be entitled to recover the full penal sum set out above, together with all court costs, all attorney fees, and any other expense of recovery.

IN TESTIMONY WHEREOF, the said PRINCIPAL and the said SURETY have caused this instrument to be signed by their respective officers this _____ of _____ Day _____ Month and Year

Principal	
Company Name	Company Name
Signature & Date	Signature & Date
Title	Title

(If Principal is a joint venture of two or more contractors, the company names, and authorized signatures of each contractor must be affixed.)

Surety	
Name of Surety	Signature of Attorney-in-Fact Signature & Date
	By:

STATE OF IL
COUNTY OF

I _____, a Notary Public in and for said county do hereby certify that

(Insert names of individuals signing on behalf of PRINCIPAL & SURETY)

who are each personally known to me to be the same persons whose names are subscribed to the foregoing instrument on behalf of PRINCIPAL and SURETY, appeared before me this day in person and acknowledged respectively, that they signed and delivered said instruments as their free and voluntary act for the uses and purposes therein set forth.

Given under my hand and notarial seal this _____ day of _____ Month and Year

(SEAL, if required by the LPA)

Notary Public Signature & Date

Date commission expires _____

Local Public Agency

County

Section Number

Village of Villa Park

DuPage

N/A

ELECTRONIC BID BOND

Electronic bid bond is allowed (box must be checked by LPA if electronic bid bond is allowed)

The Principal may submit an electronic bid bond, in lieu of completing the above section of the Proposal Bid Bond Form. By providing an electronic bid bond ID code and signing below, the Principal is ensuring the identified electronic bid bond has been executed and the Principal and Surety are firmly bound unto the LPA under the conditions of the bid bond as shown above. (If PRINCIPAL is a joint venture of two or more contractors, an electronic bid bond ID code, company/Bidder name title and date must be affixed for each contractor in the venture.)

Electronic Bid Bond ID Code

--	--	--	--	--	--	--	--	--	--	--	--	--	--	--	--	--	--	--	--

Company/Bidder Name

--

Signature & Date

--

Title

--

NOT FOR BID

Apprenticeship and Training Program Certification

Local Public Agency	County	Street Name/Road Name	Section Number
Village of Villa Park	DuPage	Various	N/A

All contractors are required to complete the following certification

- For this contract proposal or for all bidding groups in this deliver and install proposal.
- For the following deliver and install bidding groups in this material proposal.

Illinois Department of Transportation policy, adopted in accordance with the provisions of the Illinois Highway Code, requires this contract to be awarded to the lowest responsive and responsible bidder. The award decision is subject to approval by the Department. In addition to all other responsibility factors, this contract or deliver and install proposal requires all bidders and all bidder's subcontractors to disclose participation in apprenticeship or training programs that are (1) approved by and registered with the United States Department of Labor's Bureau of Apprenticeship and Training, and (2) applicable to the work of the above indicated proposals or groups. Therefore, all bidders are required to complete the following certification:

1. Except as provided in paragraph 4 below, the undersigned bidder certifies that it is a participant, either as an individual or as part of a group program, in an approved apprenticeship or training program applicable to each type of work or craft that the bidder will perform with its own employees.
2. The undersigned bidder further certifies, for work to be performed by subcontract, that each of its subcontractors either (A) is, at the time of such bid, participating in an approved, applicable apprenticeship or training program; or (B) will, prior to commencement of performance of work pursuant to this contract, establish participation in an approved apprenticeship or training program applicable to the work of the subcontract.
3. The undersigned bidder, by inclusion in the list in the space below, certifies the official name of each program sponsor holding the Certificate of Registration for all of the types of work or crafts in which the bidder is a participant and that will be performed with the bidder's employees. Types of work or craft that will be subcontracted shall be included and listed as subcontract work. The list shall also indicate any type of work or craft job category for which there is no applicable apprenticeship or training program available.

4. Except for any work identified above, if any bidder or subcontractor shall perform all or part of the work of the contract or deliver and install proposal solely by individual owners, partners or members and not by employees to whom the payment of prevailing rates of wages would be required, check the following box, and identify the owner/operator workforces and positions of ownership.

The requirements of this certification and disclosure are a material part of the contract, and the contractor shall require this certification provision to be included in all approved subcontracts. The bidder is responsible for making a complete report and shall make certain that each type of work or craft job category that will be utilized on the project is accounted for and listed. The Department at any time before or afterward may require the production of a copy of each applicable Certificate of Registration issued by the United States Department of Labor evidencing such participation by the contractor and any or all of its subcontractors. In order to fulfill the participation requirement, it shall not be necessary that any applicable program sponsor be currently taking or that it will take applications for apprenticeship, training or employment during the performance of the work of this contract or deliver and install proposal.

Bidder	Signature & Date
Title	
Address	City
	State
	Zip Code

Affidavit of Availability

For the Letting of



Bureau of Construction
2300 South Dirksen Parkway/Room 322
Springfield, IL 62764

Instructions: Complete this form by either typing or using black ink. "Authorization to Bid" will not be issued unless both sides of this form are completed in detail. Use additional forms as needed to list all work.

Part I. Work Under Contract

List below all work you have under contract as either a prime contractor or a subcontractor. It is required to include all pending low bids not yet awarded or rejected. In a joint venture, list only that portion of the work which is the responsibility of your company. The uncompleted dollar value is to be based upon the most recent engineer's or owners estimate, and must include work subcontracted to others. If no work is contracted, show NONE.

	1	2	3	4	Awards Pending	Accumulated Totals
Contract Number						
Contract With						
Estimated Completion Date						
Total Contract Price						
Uncompleted Dollar Value if Firm is the Prime Contractor						
Uncompleted Dollar Value if Firm is the Subcontractor						
Total Value of All Work						

Part II. Awards Pending and Uncompleted Work to be done with your own forces.

List below the uncompleted dollar value of work for each contract and awards pending to be completed with your own forces. All work subcontracted to others will be listed on the reverse of this form. In a joint venture, list only that portion of the work to be done by your company. If no work is contracted, show NONE.

Earthwork						
Portland Cement Concrete Paving						
HMA Plant Mix						
HMA Paving						
Clean & Seal Cracks/Joints						
Aggregate Bases, Surfaces						
Highway, R.R., Waterway Struc.						
Drainage						
Electrical						
Cover and Seal Coats						
Concrete Construction						
Landscaping						
Fencing						
Guardrail						
Painting						
Signing						
Cold Milling, Planning, Rotomilling						
Demolition						
Pavement Markings (Paint)						
Other Construction (List)						
Totals						

Disclosure of this information is REQUIRED to accomplish the statutory purpose as outlined in the "Illinois Procurement Code." Failure to comply will result in non-issuance of an "Authorization To Bid." This form has been approved by the State Forms Management Center.

Part III. Work Subcontracted to Others.

For each contract described in Part I, list all the work you have subcontracted to others.

	1	2	3	4	Awards Pending
Subcontractor					
Type of Work					
Subcontract Price					
Amount Uncompleted					
Subcontractor					
Type of Work					
Subcontract Price					
Amount Uncompleted					
Subcontractor					
Type of Work					
Subcontract Price					
Amount Uncompleted					
Subcontractor					
Type of Work					
Subcontract Price					
Amount Uncompleted					
Subcontractor					
Type of Work					
Subcontract Price					
Amount Uncompleted					
Total Uncompleted					

Notary

I, being duly sworn, do hereby declare this affidavit is a true and correct statement relating to ALL uncompleted contracts of the undersigned for Federal, State, County, City and private work, including ALL subcontract work, ALL pending low bids not yet awarded or rejected and ALL estimated completion dates.

Officer or Director

Title

Signature

Date

Company

Address

City

State

Zip Code

Subscribed and sworn to before me

this _____ day of _____, _____

(Signature of Notary Public)

My commission expires _____

(Notary Seal)

Add pages for additional contracts

Local Public Agency Formal Contract

Contractor's Name

Contractor's Address

City

State

Zip Code

STATE OF ILLINOIS

Local Public Agency

County

Section Number

Street Name/Road Name

Type of Funds

CONTRACT BOND (when required)

For a County and Road District Project

Submitted/Approved

Highway Commissioner Signature & Date

Submitted/Approved

County Engineer/Superintendent of Highways Signature & Date

For a Municipal Project

Submitted/Approved/Passed

Signature & Date

Official Title

Department of Transportation

Concurrence in approval of award

Regional Engineer Signature & Date

Local Public Agency	Local Street/Road Name	County	Section Number
Village of Villa Park	Various	DuPage	N/A

1. THIS AGREEMENT, made and concluded the _____ day of _____ between the _____
of _____, known as the party of the first part, and _____,
Local Public Agency Contractor
its successor, and assigns, known as the party of the second part.

2. For and in consideration of the payments and agreements mentioned in the Proposal hereto attached, to be made and performed by the party of the first part, and according to the terms expressed in the Bond referring this contract, the party of the second part agrees with said party of the first part, at its own proper cost and expense, to do all the work, furnish all materials and all labor necessary to complete the work in accordance with the plans and specifications hereinafter described, and in full compliance with all of the terms of this contract.

3. It is also understood and agreed that the LPA Formal Contract Proposal, Special Provisions, Affidavit of Illinois Business Office, Apprenticeship or Training Program Certification, and Contract Bond hereto attached, and the Plans for Section N/A
in Village of Villa Park, approved by the Illinois Department of Transportation on _____, are essential
Local Public Agency Date
documents of this contract and are a part hereof.

4. IN WITNESS WHEREOF, the said parties have executed this contract on the date above mentioned.

Attest: The _____ of _____
Local Public Agency Type Name of Local Public Agency

Clerk Signature & Date

(SEAL, if required by the LPA)

Party of the First Part Signature & Date

By:

(If a Corporation)

Corporate Name

President, Party of the Second Part Signature & Date

By:

(If a Limited Liability Corporation)

LLC Name

Manager or Authorized Member, Party of the Second Part

By:

(If a Partnership)

Partner Signature & Date

Partner Signature & Date

Partners doing Business under the firm name of
Party of the Second Part

(If an individual)

Party of the Second Part Signature & Date

Attest:

Secretary Signature & Date

(SEAL, if required by the LPA)

Contract Bond

Local Public Agency	County	Street Name/Road Name	Section Number
Village of Villa Park	DuPage	Various	N/A

Bond information to be returned to Local Public Agency at _____
Complete Address

We, _____
Contractor's Name and Address

a/an _____ organized under the laws of the State of _____ as PRINCIPAL, and
State

Surety Name and Address

as SURETY, are held and firmly bound unto the above Local Public Agency (hereafter referred to as "LPA") in the penal sum of _____

Dollars (_____) lawful money of the United States, to be paid to said LPA, the payment of which we bind ourselves, successors and assigns jointly to pay to the LPA this sum under the conditions of this instrument.

WHEREAS, THE CONDITION OF THE FOREGOING OBLIGATION IS SUCH that the said Principal has entered into a written contract with the LPA acting through its awarding authority for the construction of work on the above sections, which contract is hereby referred to and made a part hereof, as if written herein at length, and whereby the said Principal has promised and agreed to perform said work in accordance with the terms of said contract, and has promised to pay all sums of money due for any labor, materials, apparatus, fixtures or machinery furnished to such Principal for the purpose of performing such work and has further agreed to pay all direct and indirect damages to any person, firm, company or corporation to whom any money may be due from the Principal, subcontractor or otherwise for any such labor, materials, apparatus, fixtures or machinery so furnished and that suit may be maintained on such bond by any such person, firm, company or corporation for the recovery of any such money.

NOW, THEREFORE, if the said Principal shall perform said work in accordance with the terms of said contract, and shall pay all sums of money due or to become due for any labor, materials, apparatus, fixtures or machinery furnished to it for the purpose of constructing such work, and shall commence and complete the work within the time prescribed in said contract, and shall pay and discharge all damages, direct and indirect, that may be suffered or sustained on account of such work during the time of the performance thereof and until the said work shall have been accepted, and shall hold the LPA and its awarding authority harmless on account of any such damages and shall in all respects fully and faithfully comply with all the provisions, conditions and requirements of said contract, then this obligation shall be void; otherwise it shall remain in full force and effect.

IN TESTIMONY WHEREOF, the said PRINCIPAL and the said SURETY have caused this instrument to be signed by their respective agents this _____ day of _____
Day Month and Year

PRINCIPAL

Company Name

Company Name

By
Signature & Date

By
Signature & Date

Attest
Signature & Date

Attest
Signature & Date

(If PRINCIPAL is a joint venture of two or more contractors, the company names and authorized signature of each contractor must be affixed.)

STATE OF IL
COUNTY OF _____

I, _____, a Notary Public in and for said county, do hereby certify that
Notary Name

Insert name of Individuals signing on behalf of PRINCIPAL

who is/are each personally known to me to be the same person(s) whose name(s) is/are subscribed to the foregoing instrument on behalf of PRINCIPAL, appeared before me this day in person and acknowledged respectively, that he/she/they signed and delivered said instrument freely and voluntarily for the uses and purposes therein set forth.

Given under my hand and notarial seal this _____ day of _____
Day Month, Year

(SEAL)

Notary Public Signature & Date

[Signature Box]

Date commission expires _____

SURETY

Name of Surety

[Name of Surety Box]

Title

By:

[Title/Signature Box]

STATE OF IL
COUNTY OF _____

I, _____, a Notary Public in and for said county, do hereby certify that
Notary Name

Insert name of Individuals signing on behalf of SURETY

who is/are each personally known to me to be the same person(s) whose name(s) is/are subscribed to the foregoing instrument on behalf of SURETY, appeared before me this day in person and acknowledged respectively, that he/she/they signed and delivered said instrument freely and voluntarily for the uses and purposes therein set forth.

Given under my hand and notarial seal this _____ day of _____
Day Month, Year

(SEAL)

Notary Public Signature & Date

[Signature Box]

Date commission expires _____

Approved this _____ day of _____
Day Month, Year

Attest:

Local Public Agency Clerk Signature & Date

[Local Public Agency Clerk Signature Box]

[Local Public Agency Type Box]

Local Public Agency Type

Clerk

Awarding Authority

[Awarding Authority Box]

Awarding Authority Signature & Date

[Awarding Authority Signature Box]

**VILLAGE OF VILLA PARK
BUSINESS ENTERPRISE PROGRAM (BEP) UTILIZATION PLAN**

UTILIZATION PLAN PART I: VENDOR COMMITMENT AND SIGNATURE

The undersigned Vendor submits this Utilization Plan as part of its bid or offer in accordance with the requirements of the Village of Villa Park's DCEO Drainage Improvement Project (DCEO Grant #21-413011) and the requirements of the Business Enterprise Program (BEP). The solicitation contains a requirement that a minimum of **28%** of the value of the contract will be performed by BEP-certified vendors as defined by the Commission on Equity and Inclusion (CEI).

The Utilization Plan consists of the following parts, each of which must be completed and returned as instructed in this Commitment. No alterations of these forms will be permitted. One set of Parts I-II must be completed for the BEP requirement:

- Part I: Vendor Commitment and Signature
- Part II: Subcontractor Participation Agreement(s)
- Part IV: Utilization Plan Terms and Conditions (These terms and conditions apply to all options below but do not need to be returned.)

The undersigned Vendor acknowledges that (1) Vendor has read, understands, and agrees to BEP policies, rules, and procedures as defined in the Terms and Conditions in Part IV of this document, and (2) Vendor hereby affirms (**select one** of the options below):

- Vendor is a BEP certified firm and plans to fully meet the requirement through self-performance. (Return this Part I Signature Page only.)
- Vendor has identified BEP certified subcontractor(s) to fully meet the established BEP requirement. Only BEP certified subcontractors may be used to meet the BEP requirement if Vendor intends to meet the established requirement in whole or in part through the use of subcontractors. (Return this Part I Signature page and signed Part II Subcontractor Participation Agreement(s) to equal or exceed the requirement.)

The undersigned Vendor understands that all subcontractors identified in this Utilization Plan and Participation Agreement(s) must be certified with the Illinois Commission on Equity and Inclusion (CEI) Business Enterprise Program (BEP) at the time of submission of all bids/offers and shall perform commercially useful functions as defined in Part IV of this Utilization Plan. **We understand that compliance with this Utilization Plan is a mandated part of this solicitation and that this Utilization Plan will become a part of the contract, if awarded.** Failure to carry out the requirements of this Utilization Plan is a material breach of the resulting contract, which may result in the termination of the contract or such other remedy as the Agency deems appropriate.

Vendor Name and d/b/a: _____

Name: _____ Title: _____

Telephone: _____ Email: _____

Signature: _____ Date: _____

VILLAGE OF VILLA PARK
BUSINESS ENTERPRISE PROGRAM (BEP) UTILIZATION PLAN

UTILIZATION PLAN PART II: SUBCONTRACTOR PARTICIPATION AGREEMENT

Instructions: The Prime Vendor is required to submit a separate, signed and **fully completed Participation Agreement** from each Business Enterprise Program (BEP) certified vendor. **Once signed and submitted with the bid, this Participation Agreement, along with the other Parts of this Utilization Plan, will become a mandated part of the contract, if awarded.** The Prime Vendor shall not prohibit or otherwise limit the BEP certified vendor(s) from providing subcontractor quotes to other potential bidders.

Project Name: DCEO Drainage Improvement Project

Project Number: DCEO Grant #21-413011

Name of Prime Vendor: _____

Address: _____

City, State, and Zip: _____

Telephone: _____ **Email:** _____

Prime Vendor's contact responsible for compliance with this Participation Agreement:

Name of BEP Certified Vendor: _____

Address: _____

City, State, and Zip: _____

Telephone: _____ **Email:** _____

BEP Vendor's contact responsible for compliance with this Participation Agreement:

Type of Agreement: Services Supplies Both Services and Supplies

(a) Proposed % of Contract to be performed by the BEP Certified Vendor: _____%

NOTE: The Prime Vendor must indicate the percentage of the estimated contract award that will be subcontracted to the certified BEP Vendor.

(b) Anticipated start date of the Certified BEP Vendor: _____

(c) This participation agreement shall have a term of _____ to _____, with a total period of _____ years and _____ months, including renewals, change orders, or extensions to the underlying contract.

**VILLAGE OF VILLA PARK
BUSINESS ENTERPRISE PROGRAM (BEP) UTILIZATION PLAN**

(d) Description of work to be performed or goods/equipment to be provided by the BEP certified vendor. **This description must include identified National Institute for Public Procurement (NIGP) Class or Class Item codes.** All Participation Agreements shall be subject to Agency approval. Any changes involving or affecting the identified BEP certified vendor, scope(s) of work and NIGP Code(s) will not be permitted without notification to the soliciting Agency and BEP Compliance, in writing, and approval of the soliciting Agency. *(If more space is needed to fully describe BEP certified firm's proposed scope of work and/or payment schedule, attach additional sheets.)*

NOT FOR BEP

THE UNDERSIGNED PARTIES FURTHER AGREE that once signed and submitted with the bid, this Participation Agreement, along with the other Parts of this Utilization Plan, will become a material part of the contract, and the BEP certified vendor will perform the scope of work for the percentage as indicated above. The Undersigned Parties do also certify that they did not affix their signatures to this document until all areas under Description of Service/ Supply and Fee/Cost were completed.

Prime Vendor (Company Name and d/b/a)

Certified BEP (Company Name and d/b/a)

Name (Print)

Name (Print)

Title

Title

Signature

Date

Signature

Date

**STATE OF ILLINOIS BUSINESS ENTERPRISE PROGRAM
UTILIZATION PLAN**

UTILIZATION PLAN PART IV: TERMS OF UTILIZATION

DEFINITIONS:

“Agency” shall be defined as any State Agency, Board, or Commission under the jurisdiction of the Governor of the State of Illinois.

“University” shall be defined as any University, Department, public institution of higher education, and/or community college district within the State of Illinois.

"Business owned by a person with a disability" or "PBE" means a business concern that is at least 51% owned by one or more persons with a disability and the management and daily business operations of which are controlled by one or more of the persons with disabilities who own it. A not-for-profit agency for persons with disabilities as defined in Section 45-35 of the Illinois Procurement Code is also considered a "business owned by a person with a disability."

"Certification" means a determination made by the Council or by one delegated authority from the Council to make certifications, or by a State agency with statutory authority to make such a certification, that a business entity is a business owned by a minority, woman, or person with a disability for whatever purpose. A business owned and controlled by women shall be certified as a "woman owned business". A business owned and controlled by women who are also minorities shall be certified as both a "woman owned business" and a "minority owned business".

"Commercially Useful Function" means responsibility for the execution of a distinct element of the work of the contract, which is carried out by actually performing, managing, and supervising the work involved, evidencing the responsibilities and risks of a business owner such as negotiating the terms of (sub)contracts, taking on a financial risk commensurate with the contract or its subcontract, responsibility for acquiring the appropriate lines of credit and/or loans, or fulfilling responsibilities as a joint venture partner as described in the joint venture agreement.

“Compliance” means that a contractor has correctly implemented the requirements of this Utilization Plan.

“Contract Specific Goals” means the goals established under the Agency/University’s supplier diversity program that are based upon relevant factors, including, but not limited to, the availability of diverse businesses in the scopes of work of the contract.

“Contractor” means any person or business entity that has entered into a contract with the Agency/University, and includes all partners, affiliates, and joint ventures of such person or entity.

"Control" means the exclusive or ultimate and sole control of the business including, but not limited to, capital investment and all other financial matters, property, acquisitions, contract negotiations, legal matters, officer-director-employee selection and comprehensive hiring, operating responsibilities, cost-control matters, income and dividend matters, financial transactions and rights of other shareholders or joint partners. Control shall be real, substantial and continuing, not pro forma. Control shall include the power to direct or cause the direction of the management and policies of the business and to make the day-to-day as well as major decisions in matters of policy, management and operations. Control shall be exemplified by possessing the requisite knowledge

**STATE OF ILLINOIS BUSINESS ENTERPRISE PROGRAM
UTILIZATION PLAN**

and expertise to run the particular business and control shall not include simple majority or absentee ownership.

"Council" means the Business Enterprise Council for Minorities, Women and Persons with Disabilities.

"Diverse Firms" shall mean businesses owned by minorities, women, and persons with disabilities. Also to include, qualified service-disabled veteran-owned small businesses and qualified veteran-owned small businesses.

"Woman" shall mean a person who is a citizen or lawful permanent resident of the United States and who is of the female gender.

"Woman-owned business" or "WBE" means a business concern which is at least 51% owned by one or more women, or, in the case of a corporation, at least 51% of the stock in which is owned by one or more women; and the management and daily business operations of which are controlled by one or more of the women who own it.

"Good Faith Efforts" means actions undertaken by a bidder or contractor to achieve a Contract Specific Goal by its scope, intensity, and appropriateness to the objective, that can reasonably be expected to fulfill the program's requirements.

"Joint Venture" means an association of a diverse firm and one or more other firms to carry out a single, for-profit business enterprise, for which each joint venture partner contributes property, capital, efforts, skills and knowledge, and in which the diverse firm is responsible for a distinct, clearly defined portion of the work of the contract and whose share in the capital contribution, control, management, risks, and profits of the joint venture are commensurate with its ownership interest.

"Manufacturer" refers to a company that operates or maintains a factory or establishment that produces, on the premises, the materials, supplies, articles, or equipment required under the contract and of the general character described by the specifications.

"Minority-owned business" or "MBE" means a business concern which is at least 51% owned by one or more minority persons, or in the case of a corporation, at least 51% of the stock in which is owned by one or more minority persons; and the management and daily business operations of which are controlled by one or more of the minority individuals who own it.

"Minority person" shall mean a person who is a citizen or lawful permanent resident of the United States and who is any of the following:

(a) American Indian or Alaska Native (a person having origins in any of the original peoples of North and South America, including Central America, and who maintains tribal affiliation or community attachment).

(b) Asian (a person having origins in any of the original peoples of the Far East, Southeast Asia, or the Indian subcontinent, including, but not limited to, Cambodia, China, India, Japan, Korea, Malaysia, Pakistan, the Philippine Islands, Thailand, and Vietnam).

**STATE OF ILLINOIS BUSINESS ENTERPRISE PROGRAM
UTILIZATION PLAN**

- (c) Black or African American (a person having origins in any of the black racial groups of Africa). Terms such as "Haitian" or "Negro" can be used in addition to "Black or African American".
- (d) Hispanic or Latino (a person of Cuban, Mexican, Puerto Rican, South or Central
- (e) American, or other Spanish culture or origin, regardless of race).
- (f) Native Hawaiian or Other Pacific Islander (a person having origins in any of the original peoples of Hawaii, Guam, Samoa, or other Pacific Islands).

"NIGP Class and Class Item Codes" identify the scope(s) of work as defined by the National Institute of Governmental Procurements. This five-digit code establishes and defines the detailed scope(s) of work for the contract. The first three digits of the NIGP code represents the Class or broad category of the work to be performed, and the second two digits of the NIGP code identify a more specific focus of work within the Class category.

"Owned" means having all the customary incidents of ownership, including the right of disposition, and the sharing in all risks and profits commensurate with the degree of ownership interest.

"Person with a disability" means a person who is a citizen or lawful resident of the United States and is a person qualifying as being disabled under subdivision (Illinois Compiled Statutes 30 ILCS 575/2 subsection A).

"Qualified service-disabled veteran" means a veteran who has been found to have 10% or more service-connected disability by the United States Department of Veterans Affairs or the United States Department of Defense.

"Qualified service-disabled veteran-owned small business" or "SDVOSB" means a small business (i) that is at least 51% owned by one or more qualified service-disabled veterans living in Illinois or, in the case of a corporation, at least 51% of the stock of which is owned by one or more qualified service-disabled veterans living in Illinois; (ii) that has its home office in Illinois; and (iii) for which items (i) and (ii) are factually verified annually by the Commission on Equity and Inclusion.

"Qualified veteran-owned small business" or "VOSB" means a small business (i) that is at least 51% owned by one or more qualified veterans living in Illinois or, in the case of a corporation, at least 51% of the stock of which is owned by one or more qualified veterans living in Illinois; (ii) that has its home office in Illinois; and (iii) for which items (i) and (ii) are factually verified annually by the Commission on Equity and Inclusion.

"Regular Dealer" means a business that owns, operates, or maintains a store, warehouse, or other establishment in which the supplies, equipment, or goods (excluding software licenses) of the general character required for the Procurement are bought, kept in stock, and regularly sold or leased in the usual course of business. To be a Regular Dealer, the business must be an established business that engages, as its principal business and under its own name, in the Procurement and sale or lease of the products in question. A business may be a Regular Dealer in such bulk items as petroleum products, steel, cement, gravel, stone, or asphalt without owning, operating, or maintaining a place of business if the business both owns and operates distribution equipment

**STATE OF ILLINOIS BUSINESS ENTERPRISE PROGRAM
UTILIZATION PLAN**

for the products. Any supplementing of such business' distribution equipment shall be by a long-term lease agreement and not on an ad hoc or contract-by-contract basis. Packagers, manufacturer representatives, or other businesses who arrange or expedite transactions are not Regular Dealers.

"State contracts" means all contracts entered into by the State, any agency or department thereof, or any public institution of higher education, including community college districts, regardless of the source of the funds with which the contracts are paid, which are not subject to federal reimbursement. "State contracts" does not include contracts awarded by a retirement system, pension fund, or investment board subject to Section 1-109.1 of the Illinois Pension Code. This definition shall control over any existing definition under this Act or applicable administrative rule.

"Supplier" refers to a company that owns, operates, or maintains a store, warehouse or other establishment in which materials, supplies, articles or equipment are bought, kept in stock and regularly sold or leased to the public in the usual course of business. A regular distributor or supplier is a firm that owns, operates, or maintains a store, warehouse, or other establishment in which the materials or supplies required for performance of a contract are bought, kept in stock, and regularly sold to the public in the usual course of business. To be a regular distributor the firm must engage in, as its principal business and in its own name, the purchase and sale of the products in question. A regular distributor in bulk items such as steel, cement, gravel, stone, and petroleum products need not keep such products in stock if it owns or operates distribution equipment.

"Utilization Plan" means a form and additional documentation included in all bids or proposals that demonstrates a vendor's proposed utilization of vendors certified by the Business Enterprise Program to meet the targeted goal. The Utilization Plan shall demonstrate that the Vendor has either: (1) met the entire contract goal or (2) requested a full or partial waiver and made Good Faith Efforts towards meeting the goal.

Business Enterprise Program Aspirational Goal

The Business Enterprise for Minorities, Women, and Persons with Disabilities Act, 30 ILCS 575, establishes an aspirational goal of awarding not less than 20% of the total dollar amount of State contracts to businesses certified as owned and controlled by minorities, women, and persons with disabilities. 30 ILCS 575/4(a).

Section 45-75 of the Illinois Procurement Code, 30 ILCS 500, establishes a goal to award not less than 3% of the total dollar amount of State contracts to SDVOSBs and VOSBs.

This solicitation includes Business Enterprise Program (BEP) and/or Veterans Business Program participation goals and, therefore, requires bidders and offerors to include a BEP Utilization Plan and a VSB Utilization Plan. A "Utilization Plan" includes the form on page 1 of this document, with the Participation Agreement and Schedule(s); any additional documentation required in the instructions that demonstrates a commitment to utilizing certified BEP/VSB subcontractors to meet the targeted, contract-specific goal, described below; and documentation demonstrating Good Faith Effort when requesting a goal waiver or reduction.

**STATE OF ILLINOIS BUSINESS ENTERPRISE PROGRAM
UTILIZATION PLAN**

A properly completed BEP Utilization Plan and VSB Utilization Plan is due at the time of bid or offer submission. Failure to complete and include a BEP Utilization Plan shall render a bid or offer non-responsive. 30 ILCS 575/4(f). Non-responsive bids and offers will be rejected by the Agency/University.

In addition to the other award criteria established for this solicitation, the Agency/University will award this contract to a Vendor that meets the contract-specific goal or makes Good Faith Efforts to meet the goal. The goal is applicable to the contract, amendments, modifications, extensions, change orders, and allowances. The Vendor's Utilization Plan must indicate whether the goal will be met by self-performance or by subcontracting. If the prime Vendor is BEP certified, the entire goal can be met by Prime Vendor self-performance, without subcontracting with another certified BEP vendor. If the prime Vendor is VSB certified, the entire VSB goal can be met by Prime Vendor self-performance. However, the prime BEP or VSB Vendor must submit a Utilization Plan indicating that the goal will be met by self-performance. If a prime Vendor subcontracts any portion of a contract to non-BEP/VSB certified subcontractors, the amount paid for goods or services delivered by those subcontractors will not be counted toward the goal.

Contract (Specific) Goal to be Achieved by Vendor

This solicitation includes a contract-specific BEP/VSB participation goal based on certified BEP/VSB vendors available to perform anticipated services and/or provide supplies required by this solicitation. The availability of certified BEP/VSB vendors was determined using The Institute for Public Procurement (NIGP Class and Class Item) codes listed in the Invitation for Bid (IFB), Request for Proposal (RFP), Request for Qualifications (RFQ), or other solicitation documents.

Prime Vendors must only consider NIGP Class and Class Item codes referenced in solicitation documents when selecting BEP/VSB subcontractors or completing a Good Faith Effort. Subject to State Agency/University approval, the Prime Vendor may utilize additional codes to identify BEP/VSB vendors that will be able to perform a commercially useful function under the resulting contract through direct participation. Indirect participation will not be considered towards BEP/VSB goals. Direct participation includes work that is directly related to the completion of the scope of work of the contract. Indirect participation includes work related to other aspects of the Contractor's business. The NIGP Class and Class Item codes listed in the solicitation documents, as well as any additional codes selected by the Prime Vendor and approved by the contracting Agency/University, must be entered in Part II: Participation Agreement and Part III: Good Faith Effort Log sections of this Utilization Plan. Bidders seeking a Good Faith Effort waiver or goal reduction must contact all BEP/VSB vendors identified for respective NIGP Class and Class Item commodity/service codes listed in the solicitation documents.

The Prime Vendor must also enter into the Participation Agreement its plan to utilize each BEP/VSB subcontractor, including: (a) the proposed percentage of the contract to be performed by each BEP/VSB subcontractor; (b) the anticipated start date for each BEP/VSB subcontractor; (c) the anticipated dates and time periods of utilization of each BEP/VSB subcontractor; and (d) a detailed description of the work to be performed by each BEP/VSB subcontractor, including identified NIGP Class and Class Item commodity/service codes.

**STATE OF ILLINOIS BUSINESS ENTERPRISE PROGRAM
UTILIZATION PLAN**

This Utilization Plan must demonstrate that the prime Vendor has either: (1) met the entire contract goal; or (2) requested a full waiver and made Good Faith Efforts towards meeting the entire goal; or (3) requested a goal reduction and made Good Faith Efforts towards meeting a portion of the goal. Submission of Good Faith Effort log and appropriate documentation by Vendor shall be considered as a request for a full or partial goal waiver.

For a Utilization Plan to be considered, at the time of bid or offer, the submitting prime BEP/VSB vendor, if self-performing, or non-BEP/VSB submitting prime Vendor's proposed BEP/VSB subcontractor(s), must be certified with the Illinois Commission on Equity and Inclusion (CEI) Business Enterprise Program as a BEP certified vendor, and Sheltered Workshops must be registered with the State for procurements containing a State Use Program category.

1. Where there is a **joint venture** between a certified and non-certified vendor, the Utilization Plan must include an executed Joint Venture Agreement specifying the terms and conditions of the relationship between the parties and their rights and responsibilities to the prospective contract. The Joint Venture Agreement must clearly evidence that the BEP/VSB certified vendor will be responsible for a defined portion of the work and its responsibilities, risks, profits, contributions of capital, and personnel are proportionate to its ownership/interest percentage, as well as identifying the appropriate and specific NIGP Class and Class Item codes. It must include specific details related to the parties' contributions of capital, personnel, equipment, share of costs, insurance coverage, and other items; the scopes to be performed by BEP/VSB certified vendor(s) under its supervision; and the commitment of management, supervisory personnel, and operative personnel employed by the BEP/VSB certified vendor to be dedicated to the performance of the contract. Established Joint Venture Agreements will **only** be credited toward BEP/VSB goal achievements for specific work performed by the BEP Certified Joint Venture Vendor. **Each party to the Joint Venture Agreement must execute the bid or offer prior to submission of the bid or offer to the Agency/University.**

2. An agreement between a prime Vendor and a BEP/VSB certified vendor in which a BEP/VSB certified vendor promises not to provide subcontracting or pricing quotations to other vendors is prohibited. The Agency/University may request additional information to demonstrate compliance. Vendor agrees to cooperate promptly with the Agency/University in submitting to interviews, allowing entry to business places, providing documentation, and to soliciting the cooperation of a proposed BEP/VSB certified vendor during investigation. Failure to cooperate by a Vendor and/or BEP/VSB certified vendor may render the bidder or offeror non-responsive or not responsible. **A contract will not be awarded to a Vendor unless that Vendor's Utilization Plan is found responsive.**

3. **BEP/VSB Certified Vendor Locator References: Firms must be certified with CEI as BEP/VSB certified vendors at the time of bid or qualify for credit toward the goal through participation in the BEP Mentor/Protégé Program.** Vendors may consult CEI's BEP Vendor Directory at <https://ceibep.diversitysoftware.com/?TN=ceibep>.

4. **Vendor Assurance:** Vendor shall not discriminate based on race, color, national origin, sexual orientation or sex in the performance of this contract. Failure by Vendor to carry out these requirements is a material breach of the contract, which may result in the termination of the

**STATE OF ILLINOIS BUSINESS ENTERPRISE PROGRAM
UTILIZATION PLAN**

contract or such other remedy, as the Agency/University deems appropriate. **This assurance must be included in each subcontract that Vendor signs with a subcontractor or supplier.**

5. Calculating BEP/VSB Certified Vendor Participation: The Utilization Plan and Participation Agreement(s) identify work and/or goods/equipment anticipated to be provided by all BEP/VSB certified vendors and paid for upon satisfactory completion/delivery, based on NIGP Class and Class Item Code(s). **Only the value of payments made for services performed and/or actual supplies/goods/equipment provided by BEP/VSB certified vendors is counted toward the contract goal.** Applicable guidelines for counting payments attributable to contract goals are summarized below.

- 5.1.** The value of performed work and/or goods/equipment provided by the BEP/VSB certified vendor for the resulting contract shall be counted towards the goal. The entire amount of that portion of the contract that is performed by the BEP/VSB certified vendor, including supplies purchased or equipment leased by the BEP/VSB certified vendor shall be counted, except supplies purchased and equipment rented from the Prime Vendor submitting this bid or offer.
- 5.2.** A BEP certified prime Vendor shall count the portion of the total dollar value of the contract equal to the distinct, clearly defined portion of the work of the contract that the BEP/VSB certified prime Vendor self-performs toward the goal. A BEP/VSB certified prime Vendor shall also count the dollar value of work subcontracted to other BEP/VSB certified vendors. **Work performed by non-BEP/VSB certified parties shall not be counted toward the goal, including work that a BEP/VSB certified vendor subcontracts to non-BEP/VSB certified vendors.**
- 5.3.** A Vendor shall count toward the goal 100% of its expenditures for materials and supplies required under the contract and obtained from a BEP/VSB certified vendor manufacturer, regular dealer, or supplier. A Vendor shall also count toward the goal the following expenditures to BEP/VSB certified vendors that are not manufacturers, regular dealers, or suppliers:
 - 5.3.1.** The fees or commissions charged for providing a bona fide service, such as professional, technical, consultant or managerial services and assistance in the procurement of essential personnel, facilities, equipment, materials or supplies required for performance of the contract, provided that the fee or commission is determined by the Agency/University to be reasonable and not excessive as compared with fees customarily allowed for similar services.
 - 5.3.2.** The fees charged for delivery of materials and supplies required by the contract (but not the cost of the materials and supplies themselves) when the hauler, trucker, or delivery service is not also the manufacturer or a supplier of the materials and supplies being procured, provided that the fee is determined by the Agency/University to be reasonable and not excessive as compared with fees customarily allowed for similar services. The BEP/VSB certified vendor's trucking

**STATE OF ILLINOIS BUSINESS ENTERPRISE PROGRAM
UTILIZATION PLAN**

firm must actually be responsible for the management and supervision of the entire trucking operation for which it is responsible on the contract; and must itself own and operate at least one fully licensed, insured and operational truck used on the contract.

- 5.3.3.** The fees or commissions charged for providing any bonds or insurance specifically required for the performance of the contract, provided that the fee or commission is determined by the Agency/University to be reasonable and not excessive as compared with fees customarily allowed for similar services.
- 5.4.** BEP/VSB certified vendors who are performing on a contract as second-tier subcontractors (i.e., subcontractors hired by first-tier subcontractors to perform on the contract) may be counted in meeting the established BEP/VSB goal for this contract where the Prime Vendor will provide monthly documentation indicating the utilization of these vendors by reporting the utilization to the BEP at <https://ceibep.diversitysoftware.com/?TN=ceibep> for State Agencies and by contacting the contract administrator for Universities.
- 5.5.** A Vendor shall count towards the goal only expenditures to BEP/VSB firms that perform a **commercially useful function constituting direct participation** in the work of the contract.
- 5.5.1.** A firm is considered to perform a **commercially useful function** when it is responsible for execution of a distinct element of the work of a contract and carries out its responsibilities by actually performing, managing, and supervising the work involved. The BEP/VSB certified vendor must also be responsible, with respect to materials or supplies used on the contract, for negotiating price, determining quality and quantity, ordering the materials or supplies, and installing the materials (where applicable) and paying for the materials or supplies. To determine whether a firm is performing a commercially useful function, the Agency/University shall evaluate the amount of work subcontracted, whether the amount the firm is to be paid under the contract is commensurate with the work it actually performs, the credit claimed for its performance of the work, industry practices, and other relevant factors.
- 5.5.2.** A BEP certified vendor does not perform a commercially useful function if its role is limited to that of an extra participant in a transaction or contract through which funds are passed through to obtain BEP/VSB certified vendor participation. In determining whether a BEP/VSB certified vendor is such an extra participant, the Agency/University shall examine industry practices and similar transactions, particularly those in which BEP/VSB certified vendors actually participate in a meaningful way.
- 5.6.** A Vendor shall not count towards the goal expenditures that are not direct, necessary and related to the work of the contract. Only the amount of services and/or goods

**STATE OF ILLINOIS BUSINESS ENTERPRISE PROGRAM
UTILIZATION PLAN**

that are directly attributable to the performance of the contract shall be counted. Ineligible expenditures include, but are not limited to, general office overhead and other Vendor support activities, unless allowed by the Agency/University.

6. Good Faith Effort Procedures: Prime Vendors must submit in their bid a Utilization Plan and Participation Agreement(s) that meet or exceed the published goal. If a Prime Vendor cannot meet the stated goal, it must fill out and attach Part III of this document, explaining the Good Faith Efforts it undertook to meet the goal, including contacting all certified BEP/VSB vendors that fall under the scope of work/NIGP Class and Class Item codes identified in the solicitation documentation. Utilization Plans and attached documentation are due at the time of bid or offer submission. The Business Enterprise Council ("Council") or its delegate will consider the quality, quantity, and intensity of the Vendor's efforts to meet the BEP goal. The procuring Agency/University will consider the quality, quantity, and intensity of the Vendor's efforts to meet the VSB goal.

The Utilization Plan contains a checklist of actions that the Council or its delegate will consider as evidence of Vendor's Good Faith Efforts to meet the BEP goal and that the Agency/University will consider as evidence of Vendor's Good Faith Efforts to meet the VSB goal. Documentation that alters or replaces the Utilization Plan and/or Participation Agreement(s), other than supplemental documentation, will not be considered during the Utilization Plan review.

- 6.1.** In evaluating Vendor's Good Faith Efforts, the Council, its delegate, or an Agency/University as applicable may consider whether the ability of other bidders or offerors to meet the contract goal suggests that Good Faith Efforts could have resulted in Vendor meeting the goal.
- 6.2.** If the Council, its delegate, or an Agency/University determines that Vendor has made Good Faith Efforts to meet the BEP and VSB goal, respectively, the Agency/University may award the contract provided that Vendor is otherwise eligible for award.
- 6.3.** If the Council, its delegate, or an Agency/University, as applicable, determines that Good Faith Efforts have not been met, the bid or offer may be determined to be non-responsive by the Chief Procurement Officer.

7. Contract Compliance: Compliance with this section is an essential part of the contract. The following administrative procedures and remedies govern Vendor's compliance with the contractual obligations established by the Utilization Plan and Participation Agreement(s). **After approval of the Utilization Plan and Participation Agreement(s) as well as the award of the contract, the Utilization Plan, including all applicable Parts, becomes part of the contract.** If a Prime Vendor requested a waiver due to its inability to obtain BEP/VSB certified vendor participation equal to or exceeding the goal, and the Utilization Plan was approved and contract awarded based upon a determination of Good Faith Effort, the total dollar value of BEP/VSB certified vendor work in the approved Utilization Plan, calculated as a percentage of the total awarded contract value, shall become the final contract goal.

**STATE OF ILLINOIS BUSINESS ENTERPRISE PROGRAM
UTILIZATION PLAN**

- 7.1.** The Utilization Plan and Participation Agreement(s) may not be amended after contract execution without Agency/University prior written approval.
- 7.2. Vendor may not make modifications to its contractual BEP/VSB certified vendor commitments or substitute BEP/VSB certified vendors without the prior written Agency/University approval.** Unauthorized modifications or substitutions, including performing the work designated for a BEP/VSB certified vendor with Vendor's own forces, shall be a violation of the Utilization Plan and therefore a breach of the contract, cause to terminate the contract, and cause to seek other contract remedies or sanctions. For Agency/University approval of modifications or substitutions, the facts supporting the modifications or substitutions must not have been known nor reasonably should have been known by the parties prior to entering into the contract and/or subcontract. Vendor must negotiate with BEP/VSB certified vendors to resolve problems. Where there has been a mistake or disagreement about the scope of work and/or goods/equipment required by the contract, the BEP/VSB certified vendor can be substituted, but only where agreement cannot be reached for a reasonable price or schedule for the correct scope of work, goods and/or equipment. Any subsequent change **must** be submitted to the soliciting Agency/University and BEP Secretary, in writing, and approved by the soliciting Agency/University.
- 7.3.** Substitutions of a BEP/VSB certified vendor may be permitted under the following circumstances:
- 7.3.1.** Unavailability after receipt of reasonable notice to proceed;
 - 7.3.2.** Failure of performance;
 - 7.3.3.** Financial incapacity;
 - 7.3.4.** Refusal by the BEP/VSB certified vendor to honor the bid or proposal price or scope;
 - 7.3.5.** Material mistake of fact or law about the elements of the scope of work of a contract where a reasonable price cannot be agreed upon;
 - 7.3.6.** Failure of the BEP/VSB certified vendor to meet insurance, licensing or bonding requirements;
 - 7.3.7.** The BEP/VSB certified vendor's withdrawal of its bid or offer; and/or
 - 7.3.8.** Failure of the BEP/VSB certified vendor to maintain certification.
- 7.4.** If it becomes necessary to substitute a BEP/VSB certified vendor, the prime Vendor must notify the Agency/University and BEP Secretary, in writing, of the request to substitute a BEP/VSB certified vendor or otherwise modify the Utilization Plan and

**STATE OF ILLINOIS BUSINESS ENTERPRISE PROGRAM
UTILIZATION PLAN**

Participation Agreement(s). The request must state specific reasons for the substitution or modification. The Agency/University shall notify the Council or its delegate of the request to substitute a BEP/VSB certified vendor or change the Utilization Plan and Participation Agreement(s). The Agency/University will approve or deny a request for substitution or other change in the Utilization Plan and/or Participation Agreement(s) within five business days of receipt of the request or may request a BEP review of the documentation.

- 7.5.** Where Vendor has established the basis for the substitution to the satisfaction of the Agency/University, it must make Good Faith Efforts to meet the contract goal by substituting one or more BEP/VSB certified vendors. Documentation of a replacement BEP certified vendor, or of Good Faith Efforts to replace the BEP/VSB certified vendor, must meet the requirements of the initial Utilization Plan. If the goal cannot be reached and Good Faith Efforts have been made, Vendor may substitute with a non-BEP/VSB certified vendor.
- 7.6.** Prime Vendors are encouraged to utilize BEP/VSB certified firms. If a Vendor plans to hire a subcontractor for any scope of work that was not previously disclosed in the Utilization Plan and this increases BEP/VSB participation, Vendor must obtain the approval of the Agency/University to modify the Utilization Plan and must make Good Faith Efforts to ensure that BEP/VSB certified vendors have a fair opportunity to submit a bid or offer on the new scope of work.
- 7.7.** If the Prime Vendor wishes to substitute its BEP/VSB certified subcontractor, a BEP/VSB certified vendor Utilization Plan and Participation Agreement must be executed and submitted to the Agency/University within five (5) business days of Vendor's receipt of the Agency/University approval for the substitution. The Agency/University must supply the new BEP Utilization Plan and Participation Agreement(s) to the BEP Secretary or their designee.
- 7.8.** Vendor shall maintain a record of all relevant data with respect to the utilization of BEP/VSB certified vendors including, but not limited to, payroll records, invoices, canceled checks and books of account for a period of at least three (3) years after the completion of the contract. If the contract administrator is an Agency, Vendor shall submit monthly reports to BEP via the B2G Now Diversity Contract Monitoring System (DCMS) reporting system. **If the contract administrator is a University, Vendor shall contact the contract administrator to obtain reporting requirements.** Full access to these records shall be granted by Vendor within 48 hours of a written demand by the Agency/University, BEP Secretary, or any duly authorized representative thereof, or to any municipal, county, State or federal authorities. The Agency/University shall have the right to obtain from Vendor any additional data reasonably related or necessary to verify any representations by Vendor. After the performance of the final item of work or delivery of material by the BEP certified vendor and final payment to the BEP certified vendor by Vendor, but not later than thirty (30) calendar days after such payment, Vendor shall submit a statement confirming the final payment and the total payments

**STATE OF ILLINOIS BUSINESS ENTERPRISE PROGRAM
UTILIZATION PLAN**

made to the BEP certified vendor under the contract at <https://ceibep.diversitysoftware.com/?TN=ceibep> for contracts administrated by Agencies. For contracts administered by Universities, Vendor shall submit a statement confirming the final payment and the total payments made to the BEP/VSB certified vendor under the contract in the manner prescribed by the University contract administrator. **Vendor's failure to submit monthly reports shall constitute a material breach of this contract and subject Vendor to the remedies and penalties described in Section 7.10. For contracts administrated by Agencies, The Prime Vendor and BEP subcontractors will receive notification and instructions after the start of the contract for reporting to BEP's DCMS. Failure to report contractual spend or lack of spend monthly reporting may result in a contractual breach.**

- 7.9.** The Agency/University will annually review Vendor's compliance with these provisions and the terms of its contract. Executive Order Number 2018-06 requires review of contractual language regarding cancelation of contracts deemed not to be compliant with the BEP. Without limitation, Vendor's failure to comply with these provisions or its contractual commitments as contained in the Utilization Plan and Participation Agreement(s); failure to cooperate in providing information regarding its compliance with these provisions or its Utilization Plan; or provision of false or misleading information or statements concerning compliance, certification status or eligibility of a BEP certified vendor, Good Faith Efforts or any other material fact or representation shall constitute a material breach of this contract and entitle the Agency/University to declare a default, terminate the contract, and/or exercise those remedies provided for in the contract, law and equity.
- 7.10.** The Agency/University reserves the right to withhold payment to Vendor to enforce these provisions and Vendor's contractual commitments. Final payment shall not be made pursuant to the contract until Vendor submits sufficient documentation demonstrating compliance with its Utilization Plan and Participation Agreement(s).

**DCEO DRAINAGE IMPROVEMENT PROJECT (VARIOUS LOCATIONS)
VILLAGE OF VILLA PARK**

INDEX OF SPECIAL PROVISIONS

TITLE	PAGE NO.
SPECIAL PROVISIONS	5
DEFINITIONS	5
LOCATION OF PROJECT	5
DESCRIPTION OF PROJECT	6
GENERAL SPECIAL PROVISIONS	7
QUALIFICATIONS OF BIDDERS	7
BID PRICE LIMITATIONS	10
BIDS TO REMAIN SUBJECT TO ACCEPTANCE	10
AWARD OF CONTRACT	10
COSTS TO OWNER RESULTING FROM CONTRACTOR'S PROSECUTION OF THE WORK	11
INCREASED OR DECREASED QUANTITIES	11
FINAL INSPECTION	11
DATE OF MANUFACTURE	12
IRON, STEEL, COPPER, AND BRASS PRODUCTS	12
HOLIDAYS	13
PUBLIC CONVENIENCE AND SAFETY (D-1)	13
USE OF FIRE HYDRANTS	13
INSURANCE	14
DUST CONTROL WATERING	15
CONFLICTS WITH UTILITIES	15
SUBCONTRACTING	16
PROGRESS SCHEDULE	16
WORKING DAYS	17
WORKING HOURS	17

**DCEO DRAINAGE IMPROVEMENT PROJECT (VARIOUS LOCATIONS)
VILLAGE OF VILLA PARK**

CONTRACT TIME.....	17
FAILURE TO COMPLETE THE WORK ON TIME	19
MONIES DUE TO OWNER.....	19
PARTIAL PAYMENTS.....	19
TREE CARE.....	20
TREE DAMAGE	20
TRENCH BACKFILL AND PIPE BEDDING	21
PORTLAND CEMENT CONCRETE PAVEMENTS AND SIDEWALKS	22
ADJUSTING RINGS.....	22
MOBILIZATION.....	22
KEEPING ROADS OPEN TO TRAFFIC	23
WINTER WORK.....	23
PORTABLE TOILET.....	23
SPECIAL EVENTS.....	23
PROGRESS MEETINGS	24
OPERATION OF WATER DISTRIBUTION FACILITIES.....	24
CONSTRUCTION SAFETY AND HEALTH STANDARDS.....	24
MAINTENANCE WARRANTY.....	24
MAINTENANCE OF ROADWAYS (D-1).....	25
RESPONSIBILITY FOR VANDALISM.....	26
WORK ON COLLECTOR STREETS	26
EXCAVATION AND BACKFILLING OF DRAINAGE AND UTILITY STRUCTURES	27
SALVAGE AND DISPOSAL OF EXISTING MATERIALS	27
FRAMES, GRATES, AND LIDS	27
PROTECTION OF EXISTING DRAINAGE FACILITIES DURING CONSTRUCTION...	28
DROP HAMMERS.....	29
STORM STRUCTURES.....	29
PLUGGING EXISTING MANHOLES AND PIPES.....	30
ACCESS TO ADJACENT PROPERTIES.....	30
NOTIFICATION OF RESIDENTS.....	30

**DCEO DRAINAGE IMPROVEMENT PROJECT (VARIOUS LOCATIONS)
VILLAGE OF VILLA PARK**

PROTECTION AND RESTORATION OF PROPERTIES	31
SIGN RELOCATION	32
SAW CUTS	32
STATUS OF UTILITIES (D-1)	32
PAY ITEM SPECIAL PROVISIONS.....	36
PAY ITEM #3 – TRENCH BACKFILL.....	36
PAY ITEM #9 – INLET FILTERS.....	36
PAY ITEM #13 – PORTLAND CEMENT CONCRETE SIDEWALK	37
PAY ITEM #14 – DETECTABLE WARNINGS	37
PAY ITEM #15 – DRIVEWAY PAVEMENT REMOVAL	38
PAY ITEM #16 – SIDEWALK REMOVAL.....	38
PAY ITEM #20 – ABANDON AND FILL EXISTING STORM SEWER.....	39
PAY ITEM #21 – HOT-MIX ASPHALT DRIVEWAY PAVEMENT, 4”	39
PAY ITEM #22 – 12”X12” NDS YARD DRAIN WITH GRATE.....	40
PAY ITEM #23 – ROUNDED RIVER ROCK (1"-1.5" NOMINAL DIA.), 4" DEPTH.....	40
PAY ITEM #24 – AGGREGATE BASE (CA-1), 8” DEPTH.....	41
PAY ITEM #25 – CLASS D PATCHES, SPECIAL	41
PAY ITEM #26 – CONCRETE CURB AND GUTTER REMOVAL AND REPLACEMENT	42
PAY ITEM #27 – PARKWAY RESTORATION.....	44
PAY ITEM #28-29 – CATCH BASIN	45
PAY ITEM #30 – MANHOLE, TYPE A, 4’ DIAMETER.....	46
PAY ITEM #31 – FRAMES AND LIDS, TYPE 1.....	47
PAY ITEM #31 – FRAMES AND GRATES, TYPE 11	47
PAY ITEM #33-34, 46-48 – STORM SEWER, PVC.....	48
PAY ITEM #35 – STORM SEWER, RCP.....	48
PAY ITEM #36 – CONCRETE BULKHEAD	49
PAY ITEM #37 – TRAFFIC CONTROL AND PROTECTION (SPECIAL).....	49
PAY ITEM #38 – CONSTRUCTION LAYOUT	51

**DCEO DRAINAGE IMPROVEMENT PROJECT (VARIOUS LOCATIONS)
VILLAGE OF VILLA PARK**

PAY ITEM #39 – PRE–CONSTRUCTION VIDEO RECORDING	52
PAY ITEM #40 – WATER USAGE CREDIT	54
PAY ITEM #41 – WATER USAGE DEDUCTION	55
PAY ITEM #42 – CONTINGENCY ALLOWANCE.....	55
PAY ITEM #43 – CLEANOUTS.....	57
PAY ITEM #44 – CLASS C PATCHES, SPECIAL	58
PAY ITEM #45 – INLET, TYPE A, 2’ DIAMETER	58

APPENDIX A

- VILLAGE OF VILLA PARK ORDINANCE 3733

APPENDIX B

- IRMA CONTRACTUAL INSURANCE GUIDELINES

APPENDIX C

- INDEX FOR SUPPLEMENTAL SPECIFICATIONS AND RECURRING SPECIAL PROVISIONS
- CHECK SHEET FOR RECURRING SPECIAL PROVISIONS
- CHECK SHEET FOR LOCAL ROADS & STREETS RECURRING SPECIAL PROVISIONS
- BDE SPECIAL PROVISIONS
- SPECIAL PROVISION FOR INSURANCE (LR 107-4)
- SPECIAL PROVISION FOR EQUIPMENT RENTAL RATES (LR 109)

APPENDIX D

- DUPAGE COUNTY PREVAILING WAGE RATES

APPENDIX E

- DCEO GRANT AGREEMENT

**DCEO DRAINAGE IMPROVEMENT PROJECT (VARIOUS LOCATIONS)
VILLAGE OF VILLA PARK**

SPECIAL PROVISIONS

The following Special Provisions supplement the “Standard Specifications for Road and Bridge Construction”, adopted January 1, 2022 (referred to hereinafter as the “Standard Specifications”); the “Supplemental Specifications and Recurring Special Provisions”, adopted January 1, 2025; the “Illinois Manual on Uniform Traffic Control Devices For Streets and Highways”, latest edition (referred to hereinafter as the “IMUTCD”); and the “Standard Specifications for Water and Sewer Construction in Illinois”, latest edition (referred to hereinafter as the “Water and Sewer Specifications”). In case of conflict with any part or parts of said Specifications, these Special Provisions shall take precedence and shall govern. Where no conflict exists, the said Specifications shall apply to this Contract as if repeated in their entirety herein.

DEFINITIONS

Contractor. The individual, firm, partnership, joint venture, or corporation contracting with the Village of Villa Park for performance of prescribed work.

Department, Owner or Village. The Village of Villa Park, County of DuPage, State of Illinois.

Engineer. The Resident Engineer who is the authorized representative of the Village of Villa Park in immediate charge of the engineering details of a construction project.

LOCATION OF PROJECT

The project known as DCEO Drainage Improvement Project (Various Locations) involves various stormwater and drainage improvements at the following locations in the Village of Villa Park, DuPage County, Illinois:

Base Bid.

Ellsworth Ditch south of North Avenue, and

Ridge Road between Westmore Avenue and Roy Drive,

The approximate base bid project length is 1,159 feet (0.22 mile).

Alternate 1.

Third Avenue & Vermont Street

The approximate Alternate 1 project length is 102 feet (0.02 mile).

**DCEO DRAINAGE IMPROVEMENT PROJECT (VARIOUS LOCATIONS)
VILLAGE OF VILLA PARK**

Alternate 2.

205 S. Yale Avenue.

The approximate Alternate 2 project length is 213 feet (0.04 mile).

A location map is shown on the cover of the plans.

DESCRIPTION OF PROJECT

Project improvements consists of various stormwater and drainage improvements including the installation of approximately 1,200 linear feet of storm sewer varying in size from 6" to 18", the installation of manholes, inlets and catch basins, ditch shaping and regarding, pavement and driveway removal and replacement, earth excavation, combination concrete curb and gutter removal and installation, parkway restoration, sidewalk removal and replacement, and other related and incidental work necessary to complete the improvements as shown on the plans and as described herein.

NOT FOR BID

**DCEO DRAINAGE IMPROVEMENT PROJECT (VARIOUS LOCATIONS)
VILLAGE OF VILLA PARK**

GENERAL SPECIAL PROVISIONS

QUALIFICATIONS OF BIDDERS

Bidders shall comply with all applicable Federal, State, and local laws and requirements, and will further meet the qualifications prescribed in this and other applicable portions of these provisions.

Bidder, in submitting a Bid, certifies that Bidder is in compliance with all applicable Federal, State, and local laws and requirements, and that Bidder further meets the qualifications prescribed in this and other applicable portions of these provisions. Engineer's determination as to the compliance and qualifications of the Bidder will be final, and Bidder, in submitting a Bid, agrees to be bound by that determination.

Bidder, in submitting a Bid, certifies that Bidder is in compliance with the following requirements and qualifications. Bidder further certifies that Bidder is able to provide written evidence of Bidder's compliance with the following requirements and qualifications. Bidder shall, upon request by Engineer, submit such written evidence within five (5) calendar days of the Engineer's request, as well as any other written evidence which Engineer may deem necessary for the purpose of evaluating Bidder's qualifications.

Failure of the Bidder to respond and/or submit any and all written evidence requested by the Engineer within five (5) calendar days from the request shall be cause for rejection of the Bid and the forfeiture of the Bid Bond which shall become the property of the Village, as liquidation of damages. Award may then be made to the next lowest responsible bidder, re-advertised and re-Bid, or otherwise, as the Engineer may decide is in the best interest of the Village.

- (a) Bidder shall be qualified to do business in the State of Illinois.
- (b) Bidder shall possess either a valid Federal Employer Tax Identification Number (FEIN) or a valid Social Security Number (SSN).
- (c) Bidder shall be able to provide a street address and description of the Bidder's place of business, and the mailing address of the business, if different from the street address.
- (d) Bidder shall be able to provide the number of years Bidder has been engaged in the contracting business under the present firm name, and the name of the state where incorporated.
- (e) Bidder shall be able to provide a list of the property and equipment available to the Bidder.

**DCEO DRAINAGE IMPROVEMENT PROJECT (VARIOUS LOCATIONS)
VILLAGE OF VILLA PARK**

- (f) Bidder shall be able to provide a financial statement demonstrating that the Bidder has the financial resources to meet all obligations related to the Work.
- (g) Bidder shall maintain insurance policies with the coverages required by the Contract, and with the minimum limits of coverage required by the Contract. Bidder shall be able to provide current certificate(s) of insurance for the insurance policies held by Bidder, demonstrating that Bidder holds insurance policies with the coverages required by the contract, and with the minimum limits of coverage required by the Contract.
- (h) Bidder shall have constructed a minimum of three (3) projects of a similar nature in the immediate past five (5) years. Bidder shall be able to provide a list of all projects of a similar nature constructed by Bidder in the immediate past five (5) years, which list shall contain the minimum of three (3) such projects, which list shall provide a description and the location(s) of all such projects, and shall contain the Bidder's performance record and references, as well as the names and current contact information, including addresses and telephone numbers, of persons who acted as owners' representatives for those projects and who have knowledge of those projects, and whom Bidder agrees the Village may contact for the purpose of verifying Bidder's performance and references.
- (i) Bidder shall be able to provide a list of three (3) references (name, address and telephone number) with knowledge of the integrity and business practices of the bidder. Such references may not be persons who have been employed by Bidder as employees.
- (j) Bidder shall be able to provide a list of projects presently under Contract, the awarded Contract amount of each, the approximate adjusted Contract amount of each (if applicable), and the dollar amount or percent of completion of each.
- (k) Bidder shall be able to provide a list of Contracts which have resulted in lawsuits, whether against Bidder as a prime contractor, against Bidder as a subcontractor, or against Bidder as a party in any other capacity; or against subcontractors or suppliers performing work for Bidder or under Contract held by Bidder.
- (l) Bidder shall be able to provide a list of Contracts defaulted.
- (m) Bidder shall be able to provide a statement indicating whether or not Bidder has ever filed bankruptcy.
- (n) Bidder shall be able to provide a list of all officers of the firm, which list shall also indicate those officers who, while in the employ of the firm or in the employ

**DCEO DRAINAGE IMPROVEMENT PROJECT (VARIOUS LOCATIONS)
VILLAGE OF VILLA PARK**

of previous firms, were associated with Contracts which resulted in lawsuits, Contracts defaulted, or firms which filed for bankruptcy.

- (o) Bidder shall maintain personnel guaranteed to be employed in the responsible charge of the Work, which personnel possess sufficient technical experience to ensure the satisfactory completion of the Work. Bidder shall be able to provide the names and technical experience of such personnel, as well as statements as to whether the personnel have or have not performed satisfactorily on other contracts of like nature and magnitude or comparable difficulty at similar rate of progress.
- (p) Bidder shall be able to provide a list of subcontractors and suppliers anticipated to be employed by Bidder for the purpose of completing the Work, including the firm name, street address and description of place of business; mailing address of business (if different); phone, fax and e-mail contact information of business; name of primary contact; and a list of any projects or contracts for which Bidder currently owes monies to said firm, which list shall include a description of the project or contract, the amount currently due to said firm, the period of time for which those monies have been owed, and the expected date of payment of those monies.
- (q) Bidder shall participate in active apprenticeship and training programs approved by and registered with the United States Department of Labor Bureau of Apprenticeship and Training for each of the trades of work contemplated under the Contract. Bidder shall be able to provide evidence of Bidder's participation in such apprenticeship and training programs.
- (r) Bidder shall only employ subcontractors who meet the requirements prescribed in this section and other sections of these specifications.
- (s) Bidder shall be able to provide such other information as may assist the Village in determining whether the Bidder is adequately prepared to fulfill the Contract.

These requirements and qualifications are not intended to discourage bidding, to make it difficult for qualified Bidders to submit Bids, or to discourage beginning contractors. The purpose of these requirements and qualifications is to allow the Village to obtain sufficient information about Bidder's financial state, available equipment, personnel, and previous work experience so that the Village may mitigate the hazards involved in awarding contracts to parties who may not be qualified to perform the Work as specified.

A copy of Village of Villa Park Ordinance No. 3733, amending the requirements of bidders for construction projects, is provided as Appendix A.

**DCEO DRAINAGE IMPROVEMENT PROJECT (VARIOUS LOCATIONS)
VILLAGE OF VILLA PARK**

BID PRICE LIMITATIONS

The bid price for TRAFFIC CONTROL AND PROTECTION shall not exceed 5 percent of the total bid price. If the bid price for TRAFFIC CONTROL AND PROTECTION exceeds 5 percent of the total bid price, the Village may reject the Bid.

The bid price for CONSTRUCTION LAYOUT shall not exceed 2 percent of the total bid price. If the bid price for CONSTRUCTION LAYOUT exceeds 2 percent of the total bid price, the Village may reject the Bid.

The bid price for PRE-CONSTRUCTION VIDEO RECORDING shall not exceed 1 percent of the total bid price. If the bid price for PRE-CONSTRUCTION VIDEO RECORDING exceeds 1 percent of the total bid price, the Village may reject the Bid.

Bidder, in submitting a Bid, certifies that the Bid is in compliance with these requirements. The Village's determination as to whether or not to reject a Bid that does not comply with these requirements will be final, and Bidder, in submitting a Bid, agrees to be bound by that determination.

BIDS TO REMAIN SUBJECT TO ACCEPTANCE

All Bids shall remain subject to acceptance by the Village for a period of 90 calendar days from the date of the bid opening. The Village may extend the acceptance period by up to an additional 90 calendar days upon written notice to all Bidders by the Village. The Village may, in its sole discretion, release any Bid and return the Bid Security prior to the end of the acceptance period.

AWARD OF CONTRACT

The Village of Villa Park reserves the right to award the contract to the lowest responsible Bidder for the Base Bid or for the Base Bid plus any combination of the Alternate(s), based upon the Village's best interest. Providing the lowest bid on the Base Bid or an individual Bid Alternate does not guarantee the Contractor will be awarded the contract, as the Contractor will need to be the lowest bidder on the combination of the Base Bid and Bid Alternates that the Village ultimately selects at its own discretion.

Each Bidder must submit bids for the Base Bid and all Alternates to be eligible for the award of the contract. Failure to do so may result in rejection of the Contractor.

**DCEO DRAINAGE IMPROVEMENT PROJECT (VARIOUS LOCATIONS)
VILLAGE OF VILLA PARK**

COSTS TO OWNER RESULTING FROM CONTRACTOR'S PROSECUTION OF THE WORK

Should Contractor's prosecution of the work, or Contractor's labor, methods, or equipment result in additional costs to Owner, Contractor shall reimburse Owner for such expenses.

EJCDC 7.03:

Contractor shall be liable to Owner for the reasonable direct delay and disruption costs incurred by Owner as a result of Contractor's action or inactions.

The Contractor shall bear any extra expenses incurred by the Owner

Such reimbursement will be calculated by Owner, and may include, but not be limited to, materials, equipment, tools, labor, incidentals, benefits, consultant rates, fees, vehicle or equipment usage, mileage, materials, and reimbursables. Such reimbursement may also be subject to up to a 10% overhead fee to be added on top of all other fees.

Such reimbursement will be separate from and in addition to any liquidated damages which may be assessed.

Such reimbursement may be assessed for reasons including, but not limited to:

- Contractor's failure to notify Owner of work taking place.
- Contractor's failure to complete work as scheduled
- Contractor's failure to attend scheduled activities.

INCREASED OR DECREASED QUANTITIES

The Village reserves the right to increase or decrease the amount of work shown in the plans in accordance with Section 109 of the Standard Specifications.

FINAL INSPECTION

Final inspection shall be in accordance with Article 105.13 of the Standard Specifications, except as modified herein.

Revise the second paragraph of Article 105.13 of the Standard Specifications to read:

**DCEO DRAINAGE IMPROVEMENT PROJECT (VARIOUS LOCATIONS)
VILLAGE OF VILLA PARK**

“If the inspection discloses any work, in whole or in part, as being unsatisfactory, the Engineer will give the Contractor the necessary instructions for correction of same, and the Contractor shall comply with such instructions within 14 calendar days of receipt of such instructions. The Contractor shall give the Engineer not less than 48 hours’ notice, in writing, prior to beginning any such corrective work. Upon completion of all corrective work, the Contractor shall give the Engineer notice in writing. Upon receipt of such notice, the Engineer will make another inspection which shall constitute the final inspection provided the work has been satisfactorily completed. In such event, the Engineer will notify the Contractor in writing of the date of final inspection.”

DATE OF MANUFACTURE

Revise the second paragraph of Article 106.01 of the Standard Specifications to read:

“All materials to be permanently incorporated in the work, including, but not limited to, frames, grates, lids, castings, fire hydrants, pipe, drainage and utility structures, valves, stops, fittings, and hardware, shall have been manufactured no earlier than January 1 of the calendar year in which they are to be installed unless otherwise specifically prescribed in the contract documents.”

IRON, STEEL, COPPER, AND BRASS PRODUCTS

Revise the third paragraph of Article 106.01 of the Standard Specifications to read:

All iron, steel, copper, and brass products, which are to be incorporated into the work, shall be domestically manufactured or produced and fabricated, unless an exception is expressly permitted under Federal and/or State law and written permission is given by Owner. The Contractor shall obtain from the iron, steel, copper, or brass producer and/or fabricator, in addition to the mill analysis, a certification that all iron, steel, copper, or brass materials meet these domestic source requirements.

**DCEO DRAINAGE IMPROVEMENT PROJECT (VARIOUS LOCATIONS)
VILLAGE OF VILLA PARK**

HOLIDAYS

Revise the list of legal holidays in Article 107.09 of the Standard Specifications to read:

New Year's Day	Thanksgiving Day
Easter	Thanksgiving Friday
Memorial Day	Christmas Eve
Independence Day	Christmas Day
Labor Day	New Year's Eve

PUBLIC CONVENIENCE AND SAFETY (D-1)

Effective: May 1, 2012
Revised: July 15, 2012

Add the following to the end of the fourth paragraph of Article 107.09:

“If the holiday is on a Saturday or Sunday, and is legally observed on a Friday or Monday, the length of Holiday Period for Monday or Friday shall apply.”

Add the following sentence after the Holiday Period table in the fourth paragraph of Article 107.09:

“The Length of Holiday Period for Thanksgiving shall be from 5:00 AM the Wednesday prior to 11:59 PM the Sunday After”

Delete the fifth paragraph of Article 107.09 of the Standard Specifications:

“On weekends, excluding holidays, on roadways with Average Daily Traffic of 25,000 or greater, all lanes shall be open to traffic from 3:00 P.M. Friday to midnight Sunday except where structure construction or major rehabilitation makes it impractical.”

USE OF FIRE HYDRANTS

Revise Article 107.18 of the Standard Specifications to read:

“107.18 Use of Fire Hydrants. If Contractor requires water for the completion of construction operations, and desires to obtain water from the Village, the Contractor shall submit a written request to the Village. If such request is approved by the Village, the Contractor shall obtain water from the fire hydrant located at 100 West Home Avenue, adjacent to the Village of Villa Park Fleet Maintenance Garage. Contractor's use of said hydrant and methods of obtaining water shall be in compliance with all applicable

**DCEO DRAINAGE IMPROVEMENT PROJECT (VARIOUS LOCATIONS)
VILLAGE OF VILLA PARK**

ordinances, rules, and regulations concerning such use. Contractor shall furnish all labor and equipment necessary to make a connection to said hydrant, and to obtain and transport water.

Contractor, upon each occasion water is obtained, shall make photographic documentation of such occasion.

If Contractor makes application for temporary use of a hydrant meter and the application is not approved, Contractor shall make record of the quantity of water obtained, along with the date and time obtained, and shall report such information after each use to the Village of Villa Park Public Works Department, 11 West Home Avenue. If such use takes place outside of the normal working hours of the Public Works Department, Contractor shall report such information immediately upon the commencement of normal working hours.

Contractor shall not use, operate, or obtain water from any hydrants other than the hydrant prescribed. Contractor shall not obtain water from the Village for construction operations or activities not under contract with the Village.

If a water main break occurs and the Village determines that the water main break is a result of Contractor's use of a hydrant, the Village may require the Contractor to repair the water main break in accordance with all applicable construction standards and requirements and at no cost to the contract, or may repair the water main break by other means and invoice the Contractor for reimbursement of the Village's costs.

Water usage will be measured according to the Special Provisions WATER USAGE DEDUCTION and WATER USAGE CREDIT."

INSURANCE

Insurance and indemnification shall be in accordance with applicable sections of the Standard Specifications and shall also be in accordance with the "IRMA Contractual Insurance Guidelines", incorporated herein as Appendix B. If a conflict is determined to exist between the requirements prescribed in the Standard Specifications and the requirements prescribed in the IRMA Contractual Insurance Guidelines, such conflict will be resolved as follows:

- a. If a particular type of insurance coverage is required by one standard but not by both, that type of insurance coverage will be required.
- b. If the minimum limits of insurance coverage required by one standard differ from those required by the other standard, the higher minimum limits of insurance coverage will prevail.

**DCEO DRAINAGE IMPROVEMENT PROJECT (VARIOUS LOCATIONS)
VILLAGE OF VILLA PARK**

- c. If any other conflicts are determined to exist between the requirements prescribed in the two standards, the stricter of the two requirements will prevail. The Village will make the final determination as to what constitutes a stricter requirement.

Contractor shall provide a Certificate of Insurance prior to execution of Contract. Such Certificate of Insurance shall list the Village of Villa Park as Certificate Holder and shall also name the following entity or entities as additional insureds:

Village of Villa Park

Certificate of Insurance shall include a CG5036 Additional Insured Endorsement.

Should said Certificate of Insurance expire prior to final acceptance of the project, said certificate shall be automatically renewed and provided to the Village of Villa Park a minimum of 30 days prior to expiration.

DUST CONTROL WATERING

Contractor shall apply water by means of spraying to control dust onsite.

Materials. Water and equipment that can apply the water by means of spraying. The methods of watering must meet the approval of the ENGINEER.

DUST CONTROL WATERING shall be considered incidental to the cost of the contract and will not be paid for separately.

CONFLICTS WITH UTILITIES

Conflicts with utilities shall be in accordance with Article 107.40 of the Standard Specifications, except as modified herein.

Add the following after the first paragraph of Article 107.40 of the Standard Specifications:

“Unless otherwise specified in the contract documents, utility facilities which are encountered during construction operations and are not in direct conflict with a proposed utility to be constructed under this contract shall be left undisturbed in place and shall be protected by the Contractor against damage and the interruption of utility services as a result of construction operations.”

**DCEO DRAINAGE IMPROVEMENT PROJECT (VARIOUS LOCATIONS)
VILLAGE OF VILLA PARK**

SUBCONTRACTING

Add the following to the end of the first paragraph of Article 108.01 of the Standard Specifications:

“Should Contractor fail to respond to such request for proof from Engineer or should Engineer determine that Contractor’s response to such request is not sufficient to prove that a proposed subcontractor has the experience, ability, and equipment the work requires, Engineer may prohibit the employ of said subcontractor.”

Add the following paragraph to the end of Article 108.01 of the Standard Specifications:

“The apparent low Bidder shall submit to Owner within 7 calendar days after the receipt of bids, a list of the names of Bidder’s proposed subcontractors and material suppliers along with a description of the work to be performed or the materials to be supplied by each.”

PROGRESS SCHEDULE

Revise Article 108.02 of the Standard Specifications to read:

After the award of the contract and prior to starting work, the Contractor shall submit to the Engineer a satisfactory progress schedule or critical path schedule which shall show the proposed sequence of work, and how the Contractor proposes to complete the various items of work within the number of calendar days set up in the contract or on or before the completion date specified in the contract.

Work will not be permitted to start until a progress schedule has been submitted and approved. The contract time will commence to run in accordance with the contract documents regardless of whether a progress schedule has been submitted or approved. If the contract time has commenced to run and a progress schedule has not been submitted, the contract time will continue to run until the day that a progress schedule is submitted. The contract time will be suspended upon submittal of a progress schedule and while such progress schedule is under review. The contract time will resume to run upon provision of a response by the Engineer to the submitted progress schedule, regardless of whether such response is approval or rejection.

The progress schedule shall be used as a basis for establishing the controlling item of construction operations and for checking the progress of the work. The controlling item shall be defined as the item which must be completed either partially or completely to permit continuation of progress. It shall be the responsibility of the Contractor to show the intended rate of production for each controlling item listed on the schedule during the period such item is controlling.

**DCEO DRAINAGE IMPROVEMENT PROJECT (VARIOUS LOCATIONS)
VILLAGE OF VILLA PARK**

The Contractor shall confer with the Engineer at regular intervals in regard to the prosecution of the work according to the progress schedule or critical path schedule.

If at any time the actual progress is ten or more calendar days behind the proposed progress shown on the approved schedule, the Engineer will select the controlling item of work for the purpose of checking the progress of the work. In such cases the Contractor shall submit a satisfactory revised progress schedule or revised critical path schedule. The Engineer will continue to determine the controlling item until the Contractor has submitted a satisfactory revised progress schedule or revised critical path schedule and such schedule has been approved.

Payment under this contract may be withheld if, at any time, a satisfactory and approved progress schedule is not in place.

WORKING DAYS

Remove Article 108.04 of the Standard Specifications in its entirety.

WORKING HOURS

Working hours will be between 7:00 A.M. and 5:00 P.M., Monday through Friday, excluding holidays as designated by the Contract.

Contractor will not permit the performance of Work outside these working hours without Owner's written consent, which may be given after prior written request to Engineer, except as otherwise required for the safety of persons or the Work or property at the Site or adjacent thereto, and except as otherwise stated in the Contract Documents.

If Contractor permits the performance of Work outside these working hours, Contractor shall compensate Owner for the costs of inspection and other services provided by Owner or Engineer. Owner will determine the rates at which such inspection and other services are to be compensated. Owner will determine the interval or intervals at which billing will take place, and may, at Owner's discretion, submit invoices for payment to Contractor, or deduct the costs from any monies due or to become due to the Contractor from Owner.

CONTRACT TIME

The work shall achieve substantial completion according to the following schedule unless additional time is granted in accordance with the specifications.

**DCEO DRAINAGE IMPROVEMENT PROJECT (VARIOUS LOCATIONS)
VILLAGE OF VILLA PARK**

Base Bid.

Ellsworth Ditch south of North Avenue substantially complete by **August 1, 2025**

Ridge Road between Westmore Avenue and Roy Drive substantially complete by **August 1, 2025**

Alternate 1.

Third Avenue & Vermont Street substantially complete by **August 1, 2025**

Alternate 2.

205 S. Yale Avenue substantially complete by **August 1, 2025**

Work for the Base Bid plus any combination of the Alternate(s), shall be scheduled to occur concurrently in such a manner and in such a sequence to prevent delays and facilitate efficient restoration of the project areas.

Substantial completion shall be defined as the completion of, at a minimum, underground utility work, roadway excavation, aggregate subgrade improvements, aggregate base course placement, concrete curb and gutter installation, binder course placement, surface course placement, driveway pavement placement, sidewalk removal and replacement, grading of parkways, placement of topsoil, and such other items of work as may be identified by the Engineer.

The work shall achieve final completion in accordance with the special provision FINAL INSPECTION.

No allowance will be made for delay or suspension of the work due to the fault of the Contractor.

**DCEO DRAINAGE IMPROVEMENT PROJECT (VARIOUS LOCATIONS)
VILLAGE OF VILLA PARK**

FAILURE TO COMPLETE THE WORK ON TIME

Replace the table in Article 108.09 of the Standard Specifications with the following:

Schedule of Deductions for Each Day of Overrun in Contract Time			
Original Contract Amount		Daily Charges	
From More Than	To and Including	Calendar Day	Work Day
\$ 0	\$ 100,000	\$ 2,000	\$ 2,800
100,000	500,000	3,000	4,200
500,000	1,000,000	4,000	5,600
1,000,000	3,000,000	5,000	7,000
3,000,000	6,000,000	6,000	8,400
6,000,000	12,000,000	9,000	12,600
12,000,000	And over	25,000	35,000

Add the following paragraph to the end of Article 108.09 of the Standard Specifications:

“Liquidated damages will be charged for each day of overrun in both substantial completion deadlines and final completion deadlines.”

MONIES DUE TO OWNER

Should Contractor be subject to fines, deductions, reimbursements, liquidated damages, or other monies due to Owner, the cost thereof may be deducted from any monies due or to become due the Contractor under this contract or any other contract between the Owner and the Contractor. Bidders and Contractor, in submitting Bids, acknowledge this requirement and agree to be bound by it.

PARTIAL PAYMENTS

Add the following after the first paragraph of Article 109.07(a) of the Standard Specifications:

“Owner will deduct from the amount so determined for the completed work a sum of ten percent to be retained until the final payment. Owner may, at its discretion, reduce the percentage of such retention prior to the final payment, but in no event shall the amount retained be reduced to less than ten percent prior to substantial completion, nor shall

**DCEO DRAINAGE IMPROVEMENT PROJECT (VARIOUS LOCATIONS)
VILLAGE OF VILLA PARK**

such retention be reduced to less than two percent or less than \$5,000.00 prior to the final payment.

TREE CARE

Tree care work shall be defined as all tree pruning, tree root pruning, tree planting, tree assessment, and tree remediation. All tree care work shall be in accordance with Section 201 of the Standard Specifications, except as modified herein.

All tree care work shall be performed by an ISA Certified Arborist or shall be performed under the direct supervision of an ISA Certified Arborist. The certified arborist shall submit a copy of their current and valid certificate to the Owner prior to any tree care work taking place. The certified arborist whose certificate is provided shall be on site at all times when tree care work is taking place. All such tree care work shall either be performed by the certified arborist or shall be performed under the direct supervision of the certified arborist.

TREE DAMAGE

If any trees are damaged during the project, the Contractor shall obtain and file with the Village a tree assessment of the damaged trees. The tree assessment shall detail the health and condition of the damaged trees and shall provide a recommendation for or against retention of each affected tree. The tree assessment will not be paid for.

When, in the opinion of the Village, a tree assessment obtained by the Contractor does not represent an independent evaluation, the Village may direct the Contractor to obtain a second tree assessment of the damaged trees and may provide the Contractor with a list of not less than two ISA Certified Arborists, from which list the Contractor shall select one for completion of the second tree assessment. The second tree assessment, if so directed, will not be paid for.

When multiple tree assessments are obtained, it will be the opinion of the Village as to which tree assessment is utilized for the purposes of addressing the remaining requirements of this section. Further references to the tree assessment in this section shall refer to the tree assessment selected by the Village.

If the tree assessment results in a recommendation for retention of an affected tree, the Contractor shall perform tree remediation of the affected tree as follows.

Trees subject to tree remediation will be fertilized and treated with Paclobutrazol. Treatment shall consist of air spading 2 holes for every 3 sq. ft. of area within the dripline of the tree to a depth of 12 in. to 18 in. and backfilling with Biochar.

**DCEO DRAINAGE IMPROVEMENT PROJECT (VARIOUS LOCATIONS)
VILLAGE OF VILLA PARK**

If a tree subject to tree remediation is an Oak or an Elm species and the damage occurred between the dates of April 15 and October 15, then in addition to the Paclobutrazol treatment specified herein, the damage to the tree will be sealed in a manner approved by the Engineer.

The Owner may require the Contractor to perform additional methods of tree remediation or methods of tree remediation different from those listed if recommended by the tree assessment or deemed appropriate by the Owner.

Tree remediation will not be paid for.

If the tree assessment results in a recommendation against retention of an affected tree, the Contractor shall remove the affected tree. Should removal of the affected tree result in any additional damage to the site or result in the need for any additional restoration, Contractor shall repair or replace the damage or perform the restoration as deemed necessary by the Engineer. This work shall be in accordance with Article 201.04 of the Standard Specifications, except that the work will not be paid for.

If a tree is to be removed due to damage, a deduction will be applied to monies due or that might become due the Contractor. This Tree Damage Deduction will be applied as follows.

Trees to be removed due to damage will be measured per unit of diameter where one unit is equal to 1 in. The diameter will be measured at a point 4.5 ft. above the highest ground level at the base of the tree and will be determined by dividing the measured circumference of the tree by 3.1416.

If the tree had tree protection installed at the time of damage and if, in the opinion of the Village, the tree protection was correctly installed at the time of damage, the Tree Damage Deduction will be \$300 per unit of diameter of the tree.

If the tree did not have tree protection installed at the time of damage or if, in the opinion of the Village, the tree protection was not correctly installed at the time of damage, the Tree Damage Deduction will be \$800 per unit of diameter of the tree.

If a tree is to be removed due to damage, then in addition to the Tree Damage Deduction, Contractor shall also furnish and plant a tree of a species and caliper selected by the Owner at a location determined by the Owner. This work shall be in accordance with Section 253 of the Standard Specifications, except that the work will not be paid for.

TRENCH BACKFILL AND PIPE BEDDING

All trench backfill and pipe bedding materials furnished under this contract shall be virgin, non-recycled materials.

**DCEO DRAINAGE IMPROVEMENT PROJECT (VARIOUS LOCATIONS)
VILLAGE OF VILLA PARK**

All trench backfill shall be crushed aggregate of CA-6 gradation. The aggregate material shall be placed in lifts not exceeding 8 in. in depth, loose measurement, and compacted by mechanical means to the satisfaction of the Engineer.

All pipes installed under this contract shall be placed on a bedding of crushed aggregate of CA-7 or CA-11 gradation having a minimum thickness of 4 in. The bedding shall be placed to a minimum of 12 in. above the top of the pipe and any fittings.

The cost of furnishing and installing pipe bedding materials will not be paid for separately but shall be included in the cost of items to which this work pertains.

PORTLAND CEMENT CONCRETE PAVEMENTS AND SIDEWALKS

Where forms are to be used for the installation of concrete, all such forms shall be wood.

Wood forms for all concrete installation shall be of a width that exceeds the required thickness of the concrete being installed.

ADJUSTING RINGS

All drainage and utility structures which are constructed, reconstructed, or adjusted as a part of this contract shall have adjusting rings installed between the topmost section of the structure and the casting.

Each structure shall be fitted with a minimum of one adjusting ring and a maximum of two adjusting rings. The topmost adjusting ring on each structure shall be rubber. The second adjusting ring on each structure, if needed, shall be precast concrete with steel reinforcement. The total height of all adjusting rings on a single structure shall be a minimum of 2 in. and a maximum of 12 in.

The mating faces of adjusting rings shall be smooth, parallel, and free of cracks, chips, spalling, or casting irregularities. Rubber mastic shall be installed between each joint.

Adjusting rings will not be paid for separately but shall be included in the cost of the items to which this work pertains.

MOBILIZATION

Mobilization shall be in accordance with Section 671 of the Standard Specifications, except as modified herein.

Revise Article 671.02 of the Standard Specifications to read:

**DCEO DRAINAGE IMPROVEMENT PROJECT (VARIOUS LOCATIONS)
VILLAGE OF VILLA PARK**

“671.02 Basis of Payment. This work will not be paid for separately but shall be included in the unit bid prices of the items for which this work applies.”

KEEPING ROADS OPEN TO TRAFFIC

All roads shall remain open to traffic unless otherwise shown on the contract plans. When necessary to close one lane because of construction, the Contractor shall maintain one-way traffic during construction hours with the use of signs and flaggers as shown on the Traffic Control Standards. Two lanes of traffic will be maintained during nights and weekends when no construction activities are being carried on.

Any holes left open at the end of the workday shall be protected and plated in accordance with the IDOT Standard Specifications. The cost of this work shall not be paid for separately and is considered incidental to the cost of the contract.

WINTER WORK

If Contractor elects to begin any site work before or during winter, no additional compensation will be granted for any costs or delays incurred by the Contractor as a result of winter weather. The Contractor shall be responsible for the implementation and cost of any winter shutdown provisions which are deemed necessary by the Engineer.

PORTABLE TOILET

Contractor shall furnish a portable toilet meeting Federal, State, and local health department requirements stocked with lavatory and sanitary supplies at all times. The portable toilet shall be provided at a location approved by the Engineer. The portable toilet shall be maintained in a clean and sanitary condition and shall be emptied as needed. This work will not be paid for separately but shall be included in the cost of the contract.

SPECIAL EVENTS

The Contractor is to coordinate with the Village for any upcoming or anticipated special events to take place in or near the project area during construction.

Contractor shall make accommodations for all special events as directed by the Village or by the Engineer. Such accommodations shall include, but not be limited to, cleaning up the project area or a portion of the project area, implementing additional traffic control or safety measures, removing materials or equipment from a particular portion of the project area, ceasing construction operations in a particular portion of the project area,

**DCEO DRAINAGE IMPROVEMENT PROJECT (VARIOUS LOCATIONS)
VILLAGE OF VILLA PARK**

scheduling construction operations around special events, and other accommodations as directed.

Compliance with this special provision will not be paid for separately but shall be included in the cost of the contract.

PROGRESS MEETINGS

Construction progress meetings will be held on a weekly basis beginning when the contract time commences to run and continuing until the project achieves final completion. Owner may, at its discretion, reduce the frequency of such meetings or cancel any or all such meetings. Contractor's representative in responsible charge of the work shall be present at all scheduled progress meetings. If Contractor's representative is not present at one or more scheduled progress meetings, Contractor shall compensate Owner for the costs of attendance of such meetings by Owner's and Engineer's representatives. Owner will determine the rates at which such attendance is to be compensated. Owner will determine the interval or intervals at which billing will take place, and may, at Owner's discretion, submit invoices for payment to Contractor, or deduct the costs from any monies due or to become due to the Contractor from Owner.

OPERATION OF WATER DISTRIBUTION FACILITIES

Contractor shall not operate any water distribution facilities, including, but not limited to, valves and hydrants. If Contractor requires the operation of such facilities, Contractor shall provide a minimum of 48 hours' notice to the Village and the Village will operate such facilities.

CONSTRUCTION SAFETY AND HEALTH STANDARDS

It is a condition of this contract and shall be made a condition of each subcontract entered into pursuant to this contract that the Contractor and any Subcontractor shall not require any laborer or mechanic employed in performance of that contract to work in surroundings or under working conditions which are unsanitary, hazardous, or dangerous to their health or safety, as determined under Federal Construction Safety and Health Standards.

MAINTENANCE WARRANTY

The Contractor shall execute and deliver to the Village, before final payment will be issued, a written warranty, in a form satisfactory to the Village, which guarantees that all work is in accordance with the contract and will not be defective. This warranty shall guarantee all work for a period of 1 year from the date of final inspection.

**DCEO DRAINAGE IMPROVEMENT PROJECT (VARIOUS LOCATIONS)
VILLAGE OF VILLA PARK**

The Contractor shall furnish a warranty bond in an amount equal to 10 percent of the final contract amount, or \$30,000, whichever is greater, by a surety satisfactory to the Village to guarantee Contractor's warranty to repair defective work.

If, within the warranty period, the Village determines any work to be defective, a written notice of such deficiency will be sent to the Contractor by certified mail.

The Contractor shall, within 14 calendar days of receipt of the notice of deficiency, and without cost to the Village, correct or repair such defective work, or remove and replace the defective work in accordance with the contract requirements for the item or items in question.

If Contractor desires an extension of time to complete the corrective work, Contractor shall make such request in writing within 10 calendar days of receipt of the notice of deficiency. After the Contractor has filed a request for an extension of time, the Village will notify the Contractor, in writing, whether or not such extension will be approved.

Should the Contractor fail to complete the corrective work within the 14 calendar days or within such extended time as may have been allowed, the Contractor shall be liable and shall pay to the Village the amount shown in the Schedule of Deductions for Each Day of Overrun in Contract Time, not as a penalty but as liquidated damages, for each day of overrun beyond the 14 calendar days or such extended time as may have been allowed.

MAINTENANCE OF ROADWAYS (D-1)

Effective: September 30, 1985

Revised: November 1, 1996

Beginning on the date that work begins on this project, the Contractor shall assume responsibility for normal maintenance of all existing roadways within the limits of the improvement. This normal maintenance shall include all repair work deemed necessary by the Engineer, but shall not include snow removal operations. Traffic control and protection for maintenance of roadways will be provided by the Contractor as required by the Engineer.

If items of work have not been provided in the contract, or otherwise specified for payment, such items, including the accompanying traffic control and protection required by the Engineer, will be paid for in accordance with Article 109.04 of the "Standard Specifications".

**DCEO DRAINAGE IMPROVEMENT PROJECT (VARIOUS LOCATIONS)
VILLAGE OF VILLA PARK**

RESPONSIBILITY FOR VANDALISM

The Contractor shall be responsible for the protection of all equipment and materials. Any equipment or materials which are stolen, missing, lost, damaged, or vandalized shall be the Contractor’s responsibility to replace or repair as needed at no additional cost to the contract.

The Contractor shall be responsible for the defacement of any concrete pours before they have set up. Concrete pavement, sidewalk, driveway, or curbing that has been defaced, in the opinion of the Engineer, shall be removed and replaced by the Contractor at Contractor’s expense.

WORK ON COLLECTOR STREETS

Streets in the following list shall be defined as collector streets within and including the limits of the termini indicated. Streets that do not have termini identified shall be considered to be collector streets throughout their entire length within the limits of the Village of Villa Park.

Addison Road (St. Charles Road to Armitage Avenue)	Ardmore Avenue (IL Route 38 to Twin Lakes Park)	Armitage Avenue
Harrison Street (Ardmore Avenue to Villa Avenue)	Harvard Avenue (Jackson Street to St. Charles Road)	High Ridge Road
Highland Avenue (Ardmore Avenue to IL Route 83)	Jackson Street	Lincoln Avenue (Vermont Street to IL Route 64)
Madison Street	Pleasant Avenue	Plymouth Street
Riordan Road (Ardmore Avenue to Villa Avenue)	St. Charles Road	Summit Avenue (IL Route 38 to Kenilworth Avenue)
Sunset Drive (Westwood Avenue to Addison Road)	Vermont Street	Villa Avenue
Washington Street	Westmore Avenue (Terrace Street to IL Route 64)	

Where work takes place in or on a collector street as defined above, all trenches, excavations, street openings, and other work located within the limits of the pavement shall be either covered with steel plates or capped to finished grade with cold-mix asphalt at the end of each workday until and after such underground utility work is complete.

**DCEO DRAINAGE IMPROVEMENT PROJECT (VARIOUS LOCATIONS)
VILLAGE OF VILLA PARK**

Upon completion of such underground utility work in or on a collector street, final pavement restoration shall be completed within 7 calendar days. Final pavement restoration shall be completed without additional costs for mobilization.

Engineer may, at Engineer's discretion, waive the requirement that surface course be placed within the 7 calendar days, in which case Contractor shall place and maintain Bump signs at the location until final surface paving is completed.

EXCAVATION AND BACKFILLING OF DRAINAGE AND UTILITY STRUCTURES

Excavation, bedding and backfilling of drainage and utility structures which are constructed, reconstructed, or adjusted as a part of this contract will not be paid for separately but shall be included in the cost of the items to which this work pertains.

SALVAGE AND DISPOSAL OF EXISTING MATERIALS

Existing manufactured materials which are removed and are not to be reused, including, but not limited to, frames, grates, lids, castings, sign posts, sign panels, fire hydrants, valves, stops, and fittings, shall remain the property of the Village unless the Engineer waives this requirement as specified herein.

Existing manufactured materials which are removed and are not to be reused will be inspected by the Engineer. Materials which are determined by the Engineer to be in satisfactory condition shall remain the property of the Village and shall be delivered by the Contractor to the Village of Villa Park Public Works Department yard located at 51 South Ardmore Avenue in Villa Park. Delivery shall be made during the normal working hours of the Village of Villa Park Public Works Department and the Contractor shall coordinate the day, time, and other details of delivery with the Village.

Materials which are determined by the Engineer to be in unsatisfactory condition shall become the property of the Contractor and shall be removed from the site by the end of the workday and properly disposed of by the Contractor.

The delivery or disposal of materials will not be paid for separately but shall be included in the cost of all items that include removal of existing materials.

FRAMES, GRATES, AND LIDS

Frames, grates, lids, and all other castings furnished under this contract shall be in accordance with Section 602 and Section 604 of the Standard Specifications, except as modified herein.

**DCEO DRAINAGE IMPROVEMENT PROJECT (VARIOUS LOCATIONS)
VILLAGE OF VILLA PARK**

Castings shall conform to ASTM A48 Class 30. Castings shall be free of cracks, holes, swells, cold shuts, and patches. Castings shall not be coated or painted.

Frames, grates, lids, and other castings shall be furnished in accordance with the following:

Type 1 frames and closed lids shall be Neenah R-1713 self-sealing or approved equal.

Type 1 frames and open lids shall be Neenah R-1713 or approved equal.

Type 11 frames and grates located in barrier curb and gutter shall be Neenah R-3281-A with curb box or approved equal.

Type 11 frames and grates located in depressed curb and gutter shall be Neenah R-3281-A with depressed curb grate or approved equal.

All other castings not specified above shall be as shown on the plans or as directed by the Engineer. If any of the castings specified are not compatible in the field due to frame height or other constraints, the Contractor shall propose an alternate casting to the Engineer for approval and shall furnish the alternate casting if approved.

Frames, grates, lids, and other castings located within curb ramps or crosswalks shall be substituted with ADA compliant castings.

All closed lid castings furnished under this contract shall be self-sealing, gasketed, watertight, and shall have machined bearing surfaces and concealed pick holes. The top surface of all closed lids shall be embossed with the words "VILLAGE OF VILLA PARK". The top surface of closed lids shall also be embossed with the word "SANITARY", "STORM", or "WATER" as appropriate.

Enviro-curb logos on curb boxes for Type 11 frames and grates shall have the words "DUMP NO WASTE" and "DRAINS TO RIVER" or "DRAINS TO WATERWAY" cast into the top of all curb boxes.

This work will be paid for separately as the type of frame, lid, grate or other casting specified.

PROTECTION OF EXISTING DRAINAGE FACILITIES DURING CONSTRUCTION

Unless otherwise noted in the contract plans, the existing drainage facilities shall remain in use during the period of construction.

**DCEO DRAINAGE IMPROVEMENT PROJECT (VARIOUS LOCATIONS)
VILLAGE OF VILLA PARK**

Locations of existing drainage structures and sewers, if shown on the contract plans, are approximate. Prior to commencement of work, the Contractor, at his/her own expense, shall determine the exact location of existing structures which are within the proposed construction site.

All drainage structures are to be kept free from any debris resulting from construction operations. All work and materials necessary to prevent accumulation of debris in the drainage structure resulting from construction operations shall be removed at the Contractor's own expense, and no extra compensation will be allowed.

Unless reconstruction or adjustment of an existing manhole, catch basin, or inlet is called for in the contract plans or ordered by the Engineer, the proposed work shall meet the existing elevations of these structures. Should reconstruction or adjustment of a drainage structure be required by the Engineer in the field, the necessary work and payment shall be done in accordance with Section 602 and Article 104.02 respectively, of the Standard Specifications.

Existing frames and grates are to remain unless otherwise noted in the contract plans or as directed by the Engineer. Frames and grates that are missing or damaged prior to construction shall be replaced. The type of replacements frame or grate shall be determined by the Engineer, and replacement and payment for same shall be in accordance with Section 604 and Article 104.02 respectively, of the Standard Specifications unless otherwise noted in the plans or special provisions.

DROP HAMMERS

The use of drop hammers or similar equipment will not be permitted.

STORM STRUCTURES

All manholes, catch basins, and inlets installed under this contract shall be in accordance with Section 602 of the Standard Specifications, except as modified herein.

Unless otherwise noted, the proposed catch basin, manholes, inlets and drainage structures shall be Precast Reinforced Concrete (per Section 1042 of the Standard Specifications).

Removal of existing storm structures, if a new manhole, catch basin or inlet is to be installed at the same location, shall be included in cost of the new structure to be installed.

Removing existing storm structures shall consist of removal and disposal of existing structures in accordance with Section 605 of the Standard Specifications. The word Structure shall be understood to mean all storm manholes, catch basins and inlets.

**DCEO DRAINAGE IMPROVEMENT PROJECT (VARIOUS LOCATIONS)
VILLAGE OF VILLA PARK**

This work will be paid for at the contract unit price per EACH for catch basins, manholes and inlets.

PLUGGING EXISTING MANHOLES AND PIPES

This work shall consist of plugging holes in manholes where sewer pipes have been removed or abandoned as shown on the plans and as determined by the Engineer. The holes shall be plugged with brick and non-shrink concrete mortar to the satisfaction of the Engineer. The non-shrink concrete mortar shall completely fill the holes and keep all water from entering the manhole. When sewers to be removed or abandoned tie directly into a pipe (including blind connections and services), the pipe shall be plugged with non-shrink concrete mortar to the satisfaction of the engineer. The pipe shall be watertight, and the inside of the pipe shall be free of excess material that might restrict flow.

All labor, materials, and equipment necessary to complete the work as specified herein shall not be paid for separately, but shall be included in the bid price of the pay item requiring the pipe removal or abandonment.

ACCESS TO ADJACENT PROPERTIES

Unless otherwise specified in the contract documents or permitted by the Engineer, Contractor shall at all times maintain access to all properties, residences, and businesses located within or adjacent to the project area.

Exception will be made when concrete curb and gutter or concrete driveway pavement construction are taking place.

When access to adjacent properties is restricted due to construction, the Contractor shall maintain one-way traffic during construction hours with the use of signs and flaggers as shown on the Traffic Control Standards. Two lanes of traffic will be maintained during nights and weekends when no construction activities are being carried on.

NOTIFICATION OF RESIDENTS

The Contractor shall be responsible for notifying residents of project schedule, driveway closures, utility disconnects, irrigation system conflicts in the parkway, landscape and hardscape conflicts, and any other construction operations that may disrupt the neighborhood. The Contractor shall coordinate with the Village Engineer on the notification process, content, and lead times within 7 days of being awarded the contract. The notification process may include, but is not limited to: door to door in person notification, flyers delivered in person or sent via certified mail, and neighborhood

**DCEO DRAINAGE IMPROVEMENT PROJECT (VARIOUS LOCATIONS)
VILLAGE OF VILLA PARK**

meetings. Notification of Residents will not be paid for separately but shall be included in the cost of the contract.

PROTECTION AND RESTORATION OF PROPERTIES

If private property outside the limits of existing easements interferes with the work, the Contractor shall notify, in writing, the owners of such property, advising them of the nature of the interference and shall arrange to cooperate with them for the protection or disposition of such property. The Contractor shall furnish the Engineer with copies of such notifications and with copies of any agreements between the Contractor and the property owners concerning such protection or disposition.

The Contractor shall take all necessary precautions for the protection of public or private property, such as driveways, walls and foundations of buildings, vaults, underground structures of public utilities, underground drainage facilities, overhead structures of public utilities, landscape, hardscape, and fences contiguous to the work, for which the contract does not provide for removal or specify precautions. The Contractor shall protect and carefully preserve all official survey monuments, property marks, section markers, and Geological Survey Monuments, or other similar monuments, until the owner, or an authorized surveyor or agent has witnessed or otherwise referenced their location or relocation. The Contractor shall notify the Engineer of the presence of any such survey or property monuments as soon as they are discovered.

The Contractor shall be responsible for the damage or destruction of property of any character resulting from neglect, misconduct, or omission in manner or method of execution or nonexecution of the work, or caused by defective work or the use of unsatisfactory materials, and such responsibility shall not be released until the work has been completed and accepted and the requirements of the Specifications complied with.

Whenever public or private property is so damaged or destroyed, the Contractor shall, at no additional cost to the Owner, restore such property to a condition equal to that existing before such damage or injury was done by repairing, rebuilding, or replacing it as may be directed, or the Contractor shall otherwise make good such damage or destruction in an acceptable manner. If the Contractor fails to do so, the Engineer may, after the expiration of a period of 48 hours after giving the Contractor notice in writing, proceed to repair, rebuild, or otherwise restore such property as may be deemed necessary, and the cost thereof will be deducted from any compensation due, or which may become due, the Contractor under this or any other contract between the Owner and the Contractor.

Damage due to construction operations and equipment beyond the engineering plan quantities without written authorization will be incidental to project.

**DCEO DRAINAGE IMPROVEMENT PROJECT (VARIOUS LOCATIONS)
VILLAGE OF VILLA PARK**

The cost of all materials required and all labor necessary to comply with the above provisions will not be paid for separately, but shall be considered as included in the unit bid prices of the contract, and no additional compensation will be allowed.

SIGN RELOCATION

All existing signs that need to be temporarily removed as part of the construction process or relocated due to location of proposed curb are to be reinstalled at the same station. Sign relocation, assembly removal, storage, temporary signing, and reinstallation to be completed by the Village.

SAW CUTS

Saw cuts are required at all pavement removal limits. All saw cuts performed during the construction process will not be paid for separately but shall be included in the cost of the removal item adjacent to the saw cut.

STATUS OF UTILITIES (D-1)

Effective: June 1, 2016

Revised: January 1, 2020

Utility companies and/or municipal owners located within the construction limits of this project have provided the following information regarding their facilities and the proposed improvements. The tables below contain a description of specific conflicts to be resolved and/or facilities which will require some action on the part of the Department's contractor to proceed with work. Each table entry includes an identification of the action necessary and, if applicable, the estimated duration required for the resolution.

UTILITIES TO BE ADJUSTED

Conflicts noted below have been identified by following the suggested staging plan included in the contract. The company has been notified of all conflicts and will be required to obtain the necessary permits to complete their work; in some instances, resolution will be a function of the construction staging. The responsible agency must relocate, or complete new installations as noted below; this work has been deemed necessary to be complete for the Department's contractor to then work in the stage under which the item has been listed.

**DCEO DRAINAGE IMPROVEMENT PROJECT (VARIOUS LOCATIONS)
VILLAGE OF VILLA PARK**

Pre-Stage

STAGE / LOCATION	TYPE	DESCRIPTION	RESPONSIBLE AGENCY	ACTION
No Conflicts Anticipated				

The following contact information is what was used during the preparation of the plans as provided by the Agency/Company responsible for resolution of the conflict.

Agency/Company Responsible to Resolve Conflict	Name of contact	Phone	E-mail address

UTILITIES TO BE WATCHED AND PROTECTED

The areas of concern noted below have been identified by following the suggested staging plan included for the contract. The information provided is not a comprehensive list of all remaining utilities, but those which during coordination were identified as ones which might require the Department's contractor to take into consideration when making the determination of the means and methods that would be required to construct the proposed improvement. In some instances, the contractor will be responsible to notify the owner in advance of the work to take place so necessary staffing on the owner's part can be secured.

Pre-Stage

STAGE / LOCATION	TYPE	DESCRIPTION	RESPONSIBLE AGENCY	ACTION
Throughout Project Limits	Electrical/Street Lights	Aerial Cable, Street Light Poles	ComEd	The Contractor shall coordinate bracing and protect utility from damage during construction.

**DCEO DRAINAGE IMPROVEMENT PROJECT (VARIOUS LOCATIONS)
VILLAGE OF VILLA PARK**

Throughout Project Limits	Gas	Underground Gas Main and Services	Nicor	The Contractor shall coordinate conflicts of mains and services and protect utility from damage during construction.
Throughout Project Limits	Phone	Aerial Cable and Buried Conduit	AT&T	The Contractor shall protect utility from damage during construction.
Throughout Project Limits	Water Main	Proposed storm sewer crossing existing water main	Villa Park	The Contractor shall protect and/or brace water main as necessary.
Throughout Project Limits	Water and Sanitary Services	Proposed storm sewer crossing existing water and sanitary services	Villa Park	The Contractor shall coordinate conflicts of services and protect from damage during construction.

The following contact information is what was used during the preparation of the plans as provided by the owner of the facility.

Agency/Company Responsible to Resolve Conflict	Name of contact	Phone	E-mail address
ComEd		630-576-7094	PlanSubmittalsandMapRequests@exeloncorp.com
AT&T	Kari Martin	630-573-5789	km2618@att.com
Nicor Gas	Anna Tran	224-239-7693	atran@southernco.com Gasmaps@southernco.com
Villa Park	Kevin Mantels	630-834-8505	kmantels@invillapark.com

The above represents the best information available to the Department and is included for the convenience of the bidder. The days required for conflict resolution should be considered in the bid as this information has also been factored into the timeline identified for the project when setting the completion date. The applicable portions of the Standard Specifications for Road and Bridge Construction shall apply.

Estimated duration of time provided above for the first conflicts identified will begin on the date of the executed contract regardless of the status of the utility relocations. The

**DCEO DRAINAGE IMPROVEMENT PROJECT (VARIOUS LOCATIONS)
VILLAGE OF VILLA PARK**

responsible agencies will be working toward resolving subsequent conflicts in conjunction with contractor activities in the number of days noted.

The estimated relocation duration must be part of the progress schedule submitted by the contractor. A utility kickoff meeting will be scheduled between the Department, the Department's contractor and the utility companies when necessary. The Department's contractor is responsible for contacting J.U.L.I.E. prior to all excavation work.

NOT FOR BID

PAY ITEM SPECIAL PROVISIONS

PAY ITEM #3 – TRENCH BACKFILL

Description. This work shall consist of furnishing aggregate for backfilling all trenches made in the subgrade of the proposed improvement, and all trenches where the inner edge of the trench is within 2 ft of the proposed edge of pavement, curb, gutter, curb and gutter, stabilized shoulder, or sidewalk.

This work also includes the disposal of the surplus excavated material which is replaced by trench backfill. Such disposal shall be made according to Article 202.03.

This work shall be in accordance with Section 208 of the Standard Specifications, except as modified herein.

Method of Measurement. This work will be measured for payment in place as cubic yard.

Basis of Payment. This work will be paid for at the contract unit price per cubic yard for TRENCH BACKFILL.

PAY ITEM #9 – INLET FILTERS

Description. This work shall consist of installing, maintaining, and cleaning inlet filters as shown on the plans or as directed by the Engineer. This work shall be in accordance with Section 280 of the Standard Specifications, except as modified herein.

Inlet filters shall consist of metal frames with attached fabric bags. Contractor shall furnish inlet filters of appropriate sizes and shapes necessary to accommodate all different types of drainage structures encountered. The use of filter fabric without a frame will not be an acceptable material for inlet filters and will be rejected.

Contractor shall inspect and clean all inlet filters weekly, after every rainfall, and additionally as needed. Maintenance and cleaning of inlet filters will not be paid for separately but shall be included in the cost of this work.

Method of Measurement. This work will be measured for payment as each individual inlet filter installed and the unit of measurement will be each. No measurement will be made of maintenance and cleaning efforts. If an inlet filter is installed on multiple structures, the inlet filter will only be measured for payment once.

**DCEO DRAINAGE IMPROVEMENT PROJECT (VARIOUS LOCATIONS)
VILLAGE OF VILLA PARK**

Basis of Payment. This work will be paid for at the contract unit price per each for INLET FILTERS.

PAY ITEM #13 – PORTLAND CEMENT CONCRETE SIDEWALK

Description. This work shall consist of placing Portland Cement Concrete Sidewalk 5". This work shall be in accordance with Section 424 of the Standard Specifications, and the detail on the Plans, except as modified herein:

The sidewalk is to be placed on mechanically compacted Aggregate Base Course, Type B, 4".

Aggregate Base Course, Type B, 4" will not be paid for separately, but shall be included in the cost of PORTLAND CEMENT CONCRETE SIDEWALK 5"

The sidewalk is to be thickened to 6 inches at locations where the sidewalk crosses driveways. The 6 inch thick sidewalk through driveways will not be paid for separately, but shall be included in the cost of PORTLAND CEMENT CONCRETE SIDEWALK 5"

Method of Measurement. This work shall be measured for payment in place and the area computed in square foot.

Basis of Payment. This work will be paid for at the contract unit price per square foot for PORTLAND CEMENT CONCRETE SIDEWALK 5"

PAY ITEM #14 – DETECTABLE WARNINGS

Description. This work shall consist of installing detectable warnings. This work shall be in accordance with Section 424 of the Standard Specifications, except as modified herein.

Detectable warnings shall be installed at curb ramps and other locations where pedestrians are required to cross a hazardous vehicular way. Detectable warnings shall also be installed at alleys and commercial entrances where permanent traffic control devices are present.

Materials. Detectable warnings shall be pre-cast tiles. Installation shall be cast-in-place. Surface mounted applications will not be permitted. Detectable warnings shall be red in color. Detectable warning tiles shall be either rectangular or radial in shape as shown on the plans or as directed by the Engineer. The product or products to be used for detectable warnings shall be approved by the Engineer prior to use.

**DCEO DRAINAGE IMPROVEMENT PROJECT (VARIOUS LOCATIONS)
VILLAGE OF VILLA PARK**

Construction. Installation shall be according to the manufacturer's specifications and as directed by the Engineer.

Where a curb ramp is 5 ft. in width or less and a rectangular detectable warning tile is to be used, the installation shall consist of a single detectable warning tile. If a pre-cast detectable warning tile is not manufactured in the width of the curb ramp, a larger detectable warning tile shall be furnished and shall be cut to the width of the curb ramp.

Installation of multiple detectable warning tiles at a single curb ramp will only be permitted where a curb ramp exceeds 5 ft. in width or where radial detectable warning tiles are to be used. Where multiple detectable warning tiles are permitted at a single curb ramp, they shall be mechanically joined prior to installation.

Method of Measurement. Detectable warnings will be measured for payment in place and the area computed in square feet.

Basis of Payment. This work will be paid for at the contract unit price per square foot for DETECTABLE WARNINGS.

PAY ITEM #15 – DRIVEWAY PAVEMENT REMOVAL

Description. This work shall consist of removing driveway pavement. This work shall be in accordance with Section 440 of the Standard Specifications, except as modified herein:

Revise Section 440.07 (c) to read:

This work shall include all pavement removal and excavation required to reach the subgrade. The excavation depth shall include the excavation for the proposed aggregate base which is included in the cost of this item. The minimum excavation depth for residential driveways is 10 inches and for commercial driveways is 14 inches.

Method of Measurement. This work shall be measured for payment in place and the area computed in square yards.

Basis of Payment. This work will be paid for at the contract unit price per square yard for DRIVEWAY PAVEMENT REMOVAL.

PAY ITEM #16 – SIDEWALK REMOVAL

Description. This work shall consist of the removal and disposal of existing sidewalk at location shown on the plans or directed by the Engineer. This work shall be in accordance with Sections 202 and 440 of the Standard Specifications, except as modified herein.

**DCEO DRAINAGE IMPROVEMENT PROJECT (VARIOUS LOCATIONS)
VILLAGE OF VILLA PARK**

Excavation will not be paid for separately but shall be included in the cost of this item. The Contractor shall excavate all material necessary to meet the lines and grades shown on the plans and as directed by the Engineer.

The Contractor shall remove sidewalk to the next existing joint beyond the location specified on the plans.

Method of Measurement. Sidewalk removal will be measured for payment in place and the area computed in square feet.

Basis of Payment. This work will be paid for at the contract unit price per square foot for SIDEWALK REMOVAL.

PAY ITEM #20 – ABANDON AND FILL EXISTING STORM SEWER

Description. This work shall consist of filling existing sewers that are to be abandoned at the locations shown on the plans or as directed by the Engineer.

Existing storm sewer to be abandoned shall be drained of all water and plugged at both ends with a minimum of two (2) feet of non-shrink concrete mortar to the satisfaction of the Engineer, and the remaining empty length of pipe filled with Controlled Low Strength Material (CLSM) meeting the material requirements of Article 593.02 of the Standard Specifications.

Method of Measurement. This work will be measured for payment in feet for the pipe to be abandoned in place.

Basis of Payment. This work will be paid for at the contract unit price per foot which price shall include all materials, labor, tools and equipment, backfilling of any excavation necessary for ABANDON AND FILL EXISTING STORM SEWER at locations shown in the plans, as specified herein, and as directed by the Engineer.

PAY ITEM #21 – HOT-MIX ASPHALT DRIVEWAY PAVEMENT, 4”

Description. This work shall consist of constructing Hot-Mix Asphalt driveway pavement on a prepared subgrade at locations shown on the plans or as directed by the Engineer.

This work shall be in accordance with Section 355 and 406 of the Standard Specifications, the detail shown on the Plans, and as specified herein.

The proposed driveway pavement shall consist of 1 lift of 2 ½” HMA Binder Course, IL-19.0, N50 and 1 lift of 1 ½” HMA Surface Course, MIX D, N50 for a total of 4” of HMA. Hot-Mix Asphalt driveway pavement shall be constructed on a prepared base of

**DCEO DRAINAGE IMPROVEMENT PROJECT (VARIOUS LOCATIONS)
VILLAGE OF VILLA PARK**

mechanically compacted crushed aggregate of CA-6 gradation having a minimum compacted thickness of 6 in. for residential driveways.

All excavation, embankment, HMA Surface Course, HMA Binder Course and aggregate base course will not be paid for separately, but shall be included in this pay item. This shall include any excavation required to widen the driveway to meet Village Standards.

Method of Measurement. Hot-mix asphalt driveway pavement will be measured for payment in place and the area computed in square yards.

Basis of Payment. This work will be paid for at the contract unit price per square yard for HOT-MIX ASPHALT DRIVEWAY PAVEMENT, 4”.

PAY ITEM #22 – 12”X12” NDS YARD DRAIN WITH GRATE

Description. This work shall consist of furnishing and installing NDS, 12-inch square catch basin drains with compatible NDS grate at the locations shown on the plans. This work shall be according to the details in the plans and the manufacturer’s specifications. Contractor shall provide shop drawings to the engineer for review and approval.

Method of Measurement. This work will be measured for payment per each installed. Excavation, bedding, backfill, fittings and all other items required for this work will not be measured for payment and shall be considered included in the contract unit price.

Basis of Payment. This work will be paid for at the contract unit price per each for 12”X12” NDS YARD DRAIN WITH GRATE.

PAY ITEM #23 – ROUNDED RIVER ROCK (1”-1.5” NOMINAL DIA.), 4” DEPTH

Description. This work shall be according to Section 281 of the Standard Specifications and the following:

This work shall consist of furnishing and installing rounded river rock in the bottom of the Ellsworth ditch as shown on the plans or as directed by the Engineer.

This work shall include uniformly spreading rounded river rock, 1”-1.5” in diameter, to a minimum thickness of four inches (4”) for ditch bottom treatment.

The Engineer shall determine the limit of the ditch bottom treatment and the rounded river rock in the field.

Basis of Payment. This work will be paid for at the contract unit price per square yard for ROUNDED RIVER ROCK (1”-1.5” NOMINAL DIA.), 4” DEPTH.

**DCEO DRAINAGE IMPROVEMENT PROJECT (VARIOUS LOCATIONS)
VILLAGE OF VILLA PARK**

PAY ITEM #24 – AGGREGATE BASE (CA-1), 8” DEPTH

Description. This work shall be according to Section 351 of the Standard Specifications and the following:

This item includes furnishing and installing eight inches (8”) of aggregate base located in the bottom of the proposed Ellsworth ditch as shown on the plans or as directed by the Engineer.

This work shall include compacting, shaping and finishing crushed stone, gradation CA-1, having a minimum thickness of eight inches (8”) for ditch bottom treatment.

This item will include the preparation of base course including the installation and compacting.

The Engineer shall determine the limit of the ditch bottom treatment and the crushed stone in the field.

Basis of Payment. This work will be paid for at the contract unit price per square yard for AGGREGATE BASE (CA-1), 8” DEPTH.

PAY ITEM #25 – CLASS D PATCHES, SPECIAL

Description. This work shall consist of the removal of the existing pavement, the necessary excavation, and the replacement with hot-mix asphalt (HMA) patches at designated locations. This work shall be in accordance with Section 442 of the Standard Specifications, except as modified herein.

Remove all references to a specified type or types of patches in the Standard Specifications.

All patches shall be saw cut full-depth prior to removal of the existing pavement. Saw cuts shall be completed no more than three days prior to removal of the existing pavement. Saw cuts will not be paid for separately, but shall be included in the cost of this work.

Where patches are to be resurfaced with a subsequent lift of hot-mix asphalt, the patches shall be constructed with Hot-Mix Asphalt Binder Course, IL-19.0, N50. The minimum thickness of each lift shall be 2.25 in. The maximum thickness of each lift shall be 4 in.

Where patches are not to be resurfaced with a subsequent lift of hot-mix asphalt, the topmost lift of the patch shall be constructed with Hot-Mix Asphalt Surface Course, Mix “D”, N50. The thickness of the surface course lift shall be 2 in. Lower lifts shall be constructed with Hot-Mix Asphalt Binder Course, IL-19.0, N50. The minimum thickness

**DCEO DRAINAGE IMPROVEMENT PROJECT (VARIOUS LOCATIONS)
VILLAGE OF VILLA PARK**

of each lower binder course lift shall be 2.25 in. The maximum thickness of each lower binder course lift shall be 4 in.

Basis of Payment. This work will be paid for at the contract unit price per square yard for CLASS D PATCHES, SPECIAL, of the thickness specified.

PAY ITEM #26 – CONCRETE CURB AND GUTTER REMOVAL AND REPLACEMENT

Description. This work shall consist of removal and replacement of concrete curb and gutter as shown on the plans or as directed by the Engineer. This work shall be in accordance with Sections 440 and 606 of the Standard Specifications, except as modified herein.

Excavation will not be paid for separately but shall be included in the cost of this item. The Contractor shall excavate all material necessary to build the proposed curb and gutter subbase in accordance with Section 202 of the Standard Specifications. Excavated material will not be permitted to be stockpiled behind the curb.

Combination concrete curb and gutter shall be constructed on a prepared base of mechanically compacted crushed aggregate of CA-6 gradation having a minimum compacted thickness of 4 in.

Wood forms shall be used. Forms constructed of steel or Masonite will not be permitted. Forms for radius sections of the combination concrete curb and gutter shall be constructed of 1 in. thick wood boards.

The height of the curb head may vary as shown on the plans or as directed by the Engineer. Variations in the height of the curb head will not be paid for separately but shall be included in the cost of this item.

Where combination concrete curb and gutter is constructed across driveways, alleys, sidewalk curb ramps, or other designated areas, the top of the curb shall be depressed according to the details shown on the plans or as directed by the Engineer. The transition from full height curb to depressed curb shall be made over a distance equal to at least four times the difference in height between the full height curb and the depressed curb.

Where combination concrete curb and gutter is constructed across sidewalk curb ramps, the depressed curb shall be in compliance with all applicable requirements of the Americans with Disabilities Act (ADA) and the Proposed Guidelines for Accessible Rights-of-Way (PROWAG).

Where combination concrete curb and gutter is to be constructed adjacent to existing pavement that is not being reconstructed, the void between the existing pavement and the proposed combination concrete curb and gutter shall be filled in with a concrete wedge

**DCEO DRAINAGE IMPROVEMENT PROJECT (VARIOUS LOCATIONS)
VILLAGE OF VILLA PARK**

with a minimum width of 6 in. and a minimum thickness of 8 in. The concrete wedge shall be placed after the combination concrete curb and gutter has been placed and the forms have been removed. The placement of the concrete wedge will not be paid for separately but shall be included in the cost of this item.

Where combination concrete curb and gutter is to be constructed adjacent to proposed sidewalk to be constructed, the combination concrete curb and gutter shall be constructed first and shall be constructed with an integral poured ledge. The ledge shall extend horizontally a minimum of 3 in. from the back of the curb head of the combination concrete curb and gutter. The ledge shall be positioned so that the vertical distance from the top of the ledge to the top of the curb head is equal to the thickness of the proposed sidewalk. The ledge shall extend vertically to the bottom edge of the combination concrete curb and gutter. The construction of the integral poured ledge will not be paid for separately but shall be included in the cost of this item.

Expansion joints shall be constructed at 60 ft. maximum centers. Expansion joints shall also be constructed at all construction joints, all points of curvature, all points of tangency, within 5 ft. on either side of all curb structure castings, and at additional locations as directed by the Engineer. Expansion joints shall consist of a 1 in. thick preformed bituminous expansion joint filler that extends the full cross section of the combination concrete curb and gutter. Expansion joint filler material that is larger than the cross section of the combination concrete curb and gutter shall be cut to the exact cross section of the combination concrete curb and gutter. Expansion joints shall have two 18 in. long, No. 6 non-deformed epoxy-coated steel dowel bars placed at mid-depth. The dowel bars shall have a greased plastic expansion cap placed on one end of each dowel bar a minimum of 1 in. from the end of the dowel bar.

Where proposed combination concrete curb and gutter is to be constructed abutting existing combination concrete curb and gutter, the dowel bars shall be drilled into the existing combination concrete curb and gutter. This work will not be paid for separately but shall be included in the cost of this item.

Contraction joints shall be constructed at 15 ft. maximum centers. Where the location of a contraction joint coincides with the location of an expansion joint, the contraction joint may be omitted at the discretion of the Engineer. Contraction joints shall be tooled and sawed. Sawing of contraction joints shall commence as soon as the concrete has hardened sufficiently to permit sawing without excessive raveling, but in no case shall sawing commence less than 4 hours or more than 24 hours after the concrete is placed. Sawing of contraction joints shall be to a depth equal to 1/3 the thickness of the gutter flag and to a width of not less than 1/8 in. Contraction joints shall be sealed according to Article 420.12, except that joints shall be sealed with polysulfide or polyurethane joint sealant.

If Contractor fails to construct joints in accordance with the requirements of this provision and the curb cracks, the Contractor shall remove and replace the affected section of

**DCEO DRAINAGE IMPROVEMENT PROJECT (VARIOUS LOCATIONS)
VILLAGE OF VILLA PARK**

combination concrete curb and gutter extending the full length between the two adjacent joints on either side of the crack. This work will not be paid for but shall be at the Contractor's expense.

Upon removal of the forms from the back of the combination concrete curb and gutter, excavated areas behind the combination concrete curb and gutter shall be immediately backfilled. Areas where pavement or sidewalks are to be constructed shall be backfilled with crushed aggregate of CA-6 or CA-7 gradation and mechanically compacted. Areas where topsoil and sodding are to be placed shall be backfilled with non-organic material acceptable to the Engineer. This work will not be paid for separately but will be included in the cost of this item.

Basis of Payment. This work will be paid for at the contract unit price per foot for CONCRETE CURB AND GUTTER REMOVAL AND REPLACEMENT.

PAY ITEM #27 – PARKWAY RESTORATION

This work shall be done in accordance with Sections 211 and 252 of the Standard Specifications and the Details provided in the Plans, except where modified herein.

Description. The purpose of this work is to restore the areas disturbed by construction and/or to provide proper drainage in the parkways.

This work shall include restoring disturbed areas within the construction limits, removing excess backfill material, excavating for proposed ADA ramps, furnishing and placing 4" of topsoil in accordance with Section 211, compacting and grading to maintain positive slope, fertilizing, and sodding the areas in accordance with Section 252. Contractor is responsible for repairing any parkway settlement to the Engineer's approval.

Materials.

- (a.) Topsoil shall meet the requirements of Article 211.02.
- (b.) Salt Tolerant Sod shall meet the requirements of Article 252.02
- (c.) Fertilizer shall meet the requirements of Article 252.02

Construction. Installation of the topsoil shall be per Article 211.04. Installation of the sod and fertilizer shall be per Articles 252.03-252.06.

Add the following to the end of Article 252.03:

"The removal of excess backfill material shall be included in the pay item for PARKWAY RESTORATION."

**DCEO DRAINAGE IMPROVEMENT PROJECT (VARIOUS LOCATIONS)
VILLAGE OF VILLA PARK**

Method of Measurement. Parkway Restoration will be measured for payment in place and the area computed in square yards. To be acceptable for final payment, the sod shall be growing in place for a minimum of 30 days in a live, healthy condition. When directed by the Engineer, any defective or unacceptable sod shall be removed, replaced, and watered.

Basis of Payment. This work will be paid for at the contract unit price per square yard for PARKWAY RESTORATION.

PAY ITEM #28-29 – CATCH BASIN

Description. This work shall consist of constructing catch basins at locations shown on the plans in accordance with the detail on the plan and Section 602 of the Standard Specifications and as specified herein.

Materials. The materials shall meet the requirements of Article 602.02 of the Standard Specifications.

Construction. Structures shall be constructed in accordance with the Construction Details and Section 602 of the Standard Specifications.

The Contractor is responsible for tying in all existing storm sewers to the proposed structure. Up to 5 feet of new sewer (if required) for each existing sewer tying into the proposed structure all be considered included in the cost of this item. Connections to existing storm sewers should be made using non-shear mission couplings. The Contractor shall be responsible for verifying the size, inverts and locations of the existing sewers to be connected to the proposed structure. Any existing storm sewers that are damaged during construction shall be replaced in kind by the Contractor at no cost to the Village. The pipe, couplings, and trench back fill shall be included in the cost of the structure and will not be paid for separately.

When a proposed catch basin is to be installed at the location of an existing drainage structure, the removal of the existing structure shall be included in this item.

Removing existing drainage structures shall consist of the removal and disposal of existing catch basins and inlets in accordance with Section 604 of the Standard Specifications.

Frames, grates and lids or other castings will be paid for separately.

Method of Measurement. This work will be measured for payment as each individual structure complete installed.

**DCEO DRAINAGE IMPROVEMENT PROJECT (VARIOUS LOCATIONS)
VILLAGE OF VILLA PARK**

Basis of Payment. This work will be paid for at the contract unit price per each for CATCH BASIN, type specified.

PAY ITEM #30 – MANHOLE, TYPE A, 4' DIAMETER

Description. This work shall consist of constructing manholes at locations shown on the plans in accordance with the detail on the plan and Section 602 of the Standard Specifications and as specified herein.

Materials. The materials shall meet the requirements of Article 602.02 of the Standard Specifications.

Construction. Structures shall be constructed in accordance with the Construction Details and Section 602 of the Standard Specifications.

The Contractor is responsible for tying in all existing storm sewers to the proposed structure. Up to 5 feet of new sewer (if required) for each existing sewer tying into the proposed structure all be considered included in the cost of this item. Connections to existing storm sewers should be made using non-shear mission couplings. The Contractor shall be responsible for verifying the size, inverts and locations of the existing sewers to be connected to the proposed structure. Any existing storm sewers that are damaged during construction shall be replaced in kind by the Contractor at no cost to the Village. The pipe, couplings, and trench back fill shall be included in the cost of the structure and will not be paid for separately.

When a proposed manhole is to be installed at the location of an existing drainage structure, the removal of the existing structure shall be included in this item.

Removing existing drainage structures shall consist of the removal and disposal of existing catch basins and inlets in accordance with Section 604 of the Standard Specifications.

Frames, grates and lids or other castings will be paid for separately.

Method of Measurement. This work will be measured for payment as each individual structure complete installed.

Basis of Payment. This work will be paid for at the contract unit price per each for MANHOLE, TYPE A, 4' DIAMETER.

**DCEO DRAINAGE IMPROVEMENT PROJECT (VARIOUS LOCATIONS)
VILLAGE OF VILLA PARK**

PAY ITEM #31 – FRAMES AND LIDS, TYPE 1

Description. This work shall meet the requirements prescribed in General Special Provisions section, FRAMES, GRATES AND LIDS, shall be according to Section 602 and 604 of the Standard Specifications, the details in the plans and the following:

This item includes the replacement of frames and lids on existing structures to be adjusted or reconstructed at locations shown on the plans or as directed by the Engineer.

Type 1 frames and closed lids shall be Neenah R-1713 self-sealing or approved equal.

Type 1 frames and open lids shall be Neenah R-1713 or approved equal.

Frames and lids located within curb ramps or crosswalks shall be substituted with ADA compliant castings.

All closed lid castings shall be self-sealing, gasketed, watertight, and shall have machined bearing surfaces and concealed pick holes. The top surface of all closed lids shall be embossed with the words "VILLAGE OF VILLA PARK".

The top surface of closed lids shall also be embossed with the word "SANITARY", "STORM", or "WATER" as appropriate.

Basis of Payment. This work will be paid for at the contract unit price per each for FRAMES AND LIDS, TYPE 1 as specified.

PAY ITEM #31 – FRAMES AND GRATES, TYPE 11

Description. This work shall meet the requirements prescribed in General Special Provisions section, FRAMES, GRATES AND LIDS, shall be according to Section 602 and 604 of the Standard Specifications, the details in the plans and the following:

This item includes the replacement of frames and grates on existing structures to be adjusted or reconstructed at locations shown on the plans or as directed by the Engineer.

Type 11 frames and grates located in barrier curb and gutter shall be Neenah R-3281-A with curb box or approved equal.

Type 11 frames and grates located in depressed curb and gutter shall be Neenah R-3281-A with depressed curb grate or approved equal.

Frames and grates located within curb ramps or crosswalks shall be substituted with ADA compliant castings.

**DCEO DRAINAGE IMPROVEMENT PROJECT (VARIOUS LOCATIONS)
VILLAGE OF VILLA PARK**

Enviro-curb logos on curb boxes for Type 11 frames and grates shall have the words "DUMP NO WASTE" and "DRAINS TO RIVER" or "DRAINS TO WATERWAY" cast into the top of all curb boxes.

Basis of Payment. This work will be paid for at the contract unit price per each for FRAMES AND GRATES, TYPE 11 as specified.

PAY ITEM #33-34, 46-48 – STORM SEWER, PVC

Description. This work consists of constructing Polyvinyl chloride (PVC) pipe storm sewers on granular bedding at the locations shown on the plans or as determined by the Engineer. The material and installation requirements shall be according to the applicable portions of Section 550 of the Standard Specifications, except as modified herein. Storm sewers shall have a standard dimension ratio (SDR) equal to 26 and gasketed joints.

Materials. Storm sewers shall be Polyvinyl chloride (PVC) pressure pipe conforming to ASTM D-2241, SDR 26 and joints conforming to ASTM D-3212.

Construction Requirements. Storm sewers shall be installed on a minimum of 4-inches of granular bedding. Once the pipe has been installed the Contractor shall place bedding to 12-inches over the crown of the pipe. Bedding material will not be paid for separately but shall be included in the cost of this item.

Connections to the existing drainage systems (pipes or structures) and all material and equipment required to make the connections shall be included in the cost of this item. Connections to existing sewer pipe shall be made with Non-Shear couplings, Fernco Strongback RC Series or approved equal. The couplings shall be equipped with stainless steel bands.

Trench backfill shall be placed over the bedding material and shall be paid for as TRENCH BACKFILL.

Basis of Payment. This work will be paid for at the contract unit price per foot for STORM SEWER, PVC, of the diameter specified.

PAY ITEM #35 – STORM SEWER, RCP

Description. This work consists of constructing reinforced concrete pipe storm sewers on granular bedding at the locations shown on the plans or as determined by the Engineer. The material and installation requirements shall be according to the applicable portions of Section 550 and 1042 of the Standard Specifications and as specified herein.

**DCEO DRAINAGE IMPROVEMENT PROJECT (VARIOUS LOCATIONS)
VILLAGE OF VILLA PARK**

Materials. Storm sewer shall be reinforced concrete pipe in accordance with Section 1042 of the Standard Specifications with rubber gasket joints meeting ASTM C-443. Bedding material shall be crushed gravel or stone meeting gradation CA-7 or CA-11.

Construction Requirements. Storm sewers shall be installed on a minimum of 4-inches of granular bedding. Once the pipe has been installed the Contractor shall place bedding to 12-inches over the crown of the pipe. Bedding material will not be paid for separately but shall be included in the cost of this item.

Connections to the existing drainage systems (pipes or structures) and all material and equipment required to make the connections shall be included in the cost of this item. Connections to existing sewer pipe shall be made with Non-Shear couplings, Fernco Strongback RC Series or approved equal. The couplings shall be equipped with stainless steel bands.

Trench backfill shall be placed over the bedding material and shall be paid for as TRENCH BACKFILL.

Basis of Payment. This work will be paid for at the contract unit price per foot for STORM SEWER, RCP, of the diameter specified.

PAY ITEM #36 – CONCRETE BULKHEAD

Description. This work shall consist of constructing concrete bulkheads at the ends of abandoned pipe at the locations shown on the plans or as directed by the Engineer.

Existing storm sewer to be abandoned shall be plugged at both ends with a minimum of two (2) feet of non-shrink concrete mortar to the satisfaction of the Engineer. The bulkhead shall be water-tight and the inside of the pipe shall be free of excess material that might restrict flow.

Method of Measurement. This work will be measured for payment as each individual concrete bulkhead complete installed.

Basis of Payment. This work will be paid for as each for CONCRETE BULKHEAD.

PAY ITEM #37 – TRAFFIC CONTROL AND PROTECTION (SPECIAL)

Description. This work shall consist of the furnishing, installation, maintenance, relocation, and removal of work zone traffic control and protection. This work shall be in accordance with Section 701 of the Standard Specifications, the Supplemental Specifications, the "Illinois Manual of Uniform Traffic Control Devices", the Highway

**DCEO DRAINAGE IMPROVEMENT PROJECT (VARIOUS LOCATIONS)
VILLAGE OF VILLA PARK**

Standards and details contained in the Plans and Special Provisions, and the Special Provisions contained herein, except as modified herein.

The bid price for TRAFFIC CONTROL AND PROTECTION (SPECIAL) shall not exceed 5 percent of the total bid price. If the bid price for TRAFFIC CONTROL AND PROTECTION (SPECIAL) exceeds 5 percent of the total bid price, the Village may reject the Bid.

Special Attention is called to Article 107.09 of the Standard Specifications and the following Highway Standards, Details, Recurring Local Roads and Streets Special Provisions, and Special Provisions contained herein, relating to traffic control.

HIGHWAY STANDARDS: 701301, 701501, 701801, 701901

DETAILS:

Traffic Control and Protection for Side Roads, Intersections, and Driveways
(TC-10)

SPECIAL PROVISIONS (Included in these Special Provisions):

Maintenance of Roadways
Work Zone Traffic Control Surveillance (LRS 3)
Flaggers in Work Zones (LRS 4)
Sidewalk, Corner, or Crosswalk Closure (BDE)

Contractor shall contact the Village at least 72 hours in advance of beginning work. Construction operations shall be conducted in a manner such that streets shall be open to emergency traffic and accessible as required to local traffic. Advanced notice shall be provided to residents, police, fire, school districts, school bus companies, and trash haulers when access to any street will be temporarily closed or limited. Removal and replacement of curb and gutter and driveways shall be planned so as to cause a minimum of inconvenience to the abutting property owners. The work shall be accomplished such that the streets shall be left open to local traffic at the end of each workday.

Method of Measurement. This work will be measured for payment on a lump sum basis. No measurement will be made of any of the individual components of this work.

Basis of Payment. Traffic control and protection will be paid for at the contract lump sum price for TRAFFIC CONTROL AND PROTECTION (SPECIAL), which price shall include all of the above listed requirements, details, standards, and special provisions.

**DCEO DRAINAGE IMPROVEMENT PROJECT (VARIOUS LOCATIONS)
VILLAGE OF VILLA PARK**

PAY ITEM #38 – CONSTRUCTION LAYOUT

Description. The Contractor shall furnish and place construction layout stakes for this project. Reference points to the centerline of survey and bench marks as shown in the plans. Any additional control points set by the Engineer will be identified in the field to the Contractor and all field notes will be kept in the office of the Engineer.

The Contractor shall provide field forces, equipment, and material to set all additional stakes for this project, which are needed to establish offset stakes, reference points, and any other horizontal or vertical controls, including supplementary bench marks, necessary to secure a correct layout of the work. Stakes for line and grade of pavement and/or curb shall be set at sufficient station intervals (not to exceed 50 feet to assure substantial conformance to plan line and grade.

The Contractor shall be responsible for having the finished work conform to the lines, grades, elevations, and dimensions called for in the plans. Any inspection or checking of the Contractor's layout by the Engineer and the acceptance of all or any part of it shall not relieve the Contractor of responsibility to secure the proper dimensions, grades and elevations of the several parts of the work. The Contractor shall exercise care in the preservation of stakes and bench marks and shall have them reset when any are damaged, lost, displaced, removed, or otherwise obliterated.

Responsibility of the Engineer

The Engineer will make random checks of the Contractor's staking to determine if the work is in conformance with the plans. Where the Contractor's work will tie into work that is being or will be done by others, checks will be made to determine if the work is in conformance with the proposed overall grade and horizontal alignment.

It is not the responsibility of the Engineer, except as provided herein, to check the correctness of the Contractor's stakes; any errors apparent will be immediately called to the Contractor's attention and the Contractor shall make the necessary correction before the stakes are used for construction purposes.

Responsibility of the Contractor

The Contractor shall establish from the given survey points and bench marks all the control points necessary to construct the individual project elements. The Contractor shall provide the Engineer adequate control in close proximity to each individual element to allow adequate checking of construction operations. This includes, but is not limited to, line and grades in substantially completed construction work. It is the Contractor's responsibility to tie in centerline control points in order to preserve them during construction operations.

**DCEO DRAINAGE IMPROVEMENT PROJECT (VARIOUS LOCATIONS)
VILLAGE OF VILLA PARK**

All work shall be according to normally accepted self-checking surveying practices. Field notes shall be kept in standard survey field notebooks and those books shall become the property of the Engineer at the completion of the project. All notes shall be neat, orderly and in accepted form.

Basis of Payment. This work will be paid for at the contract lump sum price for CONSTRUCTION LAYOUT.

PAY ITEM #39 – PRE-CONSTRUCTION VIDEO RECORDING

Description. This work shall consist of performing color video and audio recording of the project area and other areas which may be impacted by construction.

Pre-construction video recordings will include coverage of the project area and all other areas which may be impacted by construction. Video recordings will also include construction easements when applicable. Video recordings will provide a visual record of all physical features within those areas, including, but not limited to, roadways, pavements, curbs, gutters, driveways, driveway aprons, sidewalks, carriage walks, parkways, trees, landscaping, shrubbery, plantings, landscaping walls, retaining walls, signs, sign posts, fences, utility poles, light poles, utilities, equipment, manholes, b-boxes, cleanouts, valves, curb structures, pipelines, buildings, mailboxes, and any other features located within the project area.

Video recordings will begin with an audio narrative which provides the current date and time, the name of the Village and name of project, and a description of both the starting location and the location or locations to be recorded, including street name or names, street addresses, and any additional information which may be necessary to describe the location and subject of viewing.

Video recordings will maintain viewer orientation by means of an audio commentary in the audio track of each video recording which provides an explanation of what is being viewed; and by videotaping landmarks and readily identifiable objects, including property addresses, street signs, or other appropriate objects, at appropriate intervals.

Pre-construction video recordings will be recorded at a rate of travel not exceeding 50 feet per minute, and zooming and panning rates will be controlled to provide clarity of features during playback. The finished product will be provided with bright, clear pictures and accurate colors free from distortion, tearing, rolls, or other forms of picture imperfection. The audio will have proper volume and clarity. All recordings will be performed at times of satisfactory visibility, and when no more than 10 percent of ground is obscured by snow, leaves, or other cover.

If any element within or portion of the project area is not adequately documented by the pre-construction video recording so as to definitively demonstrate its condition prior to the

**DCEO DRAINAGE IMPROVEMENT PROJECT (VARIOUS LOCATIONS)
VILLAGE OF VILLA PARK**

start of construction, Contractor will assume responsibility for the repair, restoration or replacement of that element or portion of the project area. Such repair, restoration or replacement will be to equal or better condition than previously existing, and will further comply with all standards and provisions which govern the work in question.

Schedule. Preconstruction video recording will be performed according to the following schedule:

- (a) Pre-construction video recording will be completed after a Notice to Proceed has been issued.
- (b) Pre-construction video recording will be completed after the Joint Utility Locating Information for Excavators (JULIE) request for the project area has cleared.
- (c) Pre-construction video recording will be completed before any equipment, materials, or other items are delivered to the site.
- (d) Pre-construction video recording will be completed no more than 7 chargeable days prior to the start of construction.
- (e) Pre-construction video recording will be completed, the required pre-construction video recording deliverables will be submitted to the Engineer, and the Engineer will review and issue written approval of the pre-construction video recording before any activity other than utility locating will be permitted to start. Such activity will include, but not be limited to, delivery of materials and equipment, installation of traffic control and erosion control, and completion of construction layout and tree protection. No days will be charged against the contract time while the video is under review by the Engineer, including the day the deliverables are submitted and the day a response is provided. If the pre-construction video recording or any portions thereof are rejected, the contract time will commence to run until revisions are submitted.
- (f) Pre-construction video recording will be submitted to Engineer for review prior to commencement of any construction, and receive acceptance of recordings prior to commencement of construction. Any areas found not acceptable to the Owner will be re-recorded at no additional cost to the contract.

Deliverables. Video will be high-definition, with a minimum resolution of 1280 × 720 pixels per frame. Video will be filmed in a landscape aspect ratio. Video filmed in a portrait aspect ratio will be considered unacceptable and will be rejected.

Preconstruction video recordings will be provided as electronic files of .avi, .mp4, .m4v, .mkv, .wmv, or .mpg file format, or of such other file format as may be approved by Engineer. Preconstruction video recordings will be provided as independent digital

**DCEO DRAINAGE IMPROVEMENT PROJECT (VARIOUS LOCATIONS)
VILLAGE OF VILLA PARK**

container format files, which container files will include all video, audio, and other electronic information necessary to view the preconstruction video recording as intended.

Video DVD will be considered an unacceptable format for providing preconstruction video recordings, and will be rejected.

Pre-construction video recording electronic files will be provided on a portable electronic media device or devices of one of the following types: USB flash drive, SD flash memory card, CF flash memory card, data DVD, external hard drive, or such other portable electronic media device as may be approved by Engineer. Preconstruction video recording electronic files may also be provided via online file sharing, cloud storage, File Transfer Protocol (FTP), or other online or network file transfer methods if approved by Engineer.

Pre-construction video recording electronic files will be accompanied by corresponding logs which document the dates, times, and locations covered by each preconstruction video recording electronic file.

Contractor shall maintain copies of all items submitted to Engineer for Contractor's own use and record.

Method of Measurement. This work will be measured for payment on a lump sum basis. No measurement will be made of the individual components of this effort.

Basis of Payment. Pre-construction video recording will be paid for at the contract lump sum price for PRE-CONSTRUCTION VIDEO RECORDING.

PAY ITEM #40 – WATER USAGE CREDIT

Description. Pay items are provided as a part of this contract for the purpose of documenting the quantity of water obtained from the Village by the Contractor.

If the Contractor elects to obtain water from the Village, the Contractor shall comply with the Special Provision USE OF FIRE HYDRANTS. The quantity of water obtained from the Village by the Contractor shall be deducted from the contract as WATER USAGE DEDUCTION, and shall be credited to the contract as WATER USAGE CREDIT.

The WATER USAGE CREDIT pay item for this contract has been established with a unit of measurement in thousands of gallons (TGAL), a quantity of one-hundred (100.00), and a contract unit price of eight dollars and eighty-five cents (\$8.85), for a total WATER USAGE CREDIT contract price of eight-hundred eighty-five dollars and no cents (\$885.00). Bidder, in submitting a bid, accepts the quantity, contract unit price, and total contract price of the WATER USAGE CREDIT pay item.

**DCEO DRAINAGE IMPROVEMENT PROJECT (VARIOUS LOCATIONS)
VILLAGE OF VILLA PARK**

Method of Measurement. Water usage will be measured as the actual quantity of water obtained from the Village by the Contractor, which quantity shall be rounded up to the nearest 1,000 gallons.

Basis of Payment. The water usage credit will be paid for at the contract unit price per thousand gallons (TGAL) for WATER USAGE CREDIT. The quantity paid for as WATER USAGE CREDIT will be equal to the quantity deducted as WATER USAGE DEDUCTION.

PAY ITEM #41 – WATER USAGE DEDUCTION

Description. Pay items are provided as a part of this contract for the purpose of documenting the quantity of water obtained from the Village by the Contractor.

If the Contractor elects to obtain water from the Village, the Contractor shall comply with the Special Provision USE OF FIRE HYDRANTS. The quantity of water obtained from the Village by the Contractor shall be deducted from the contract as WATER USAGE DEDUCTION, and shall be credited to the contract as WATER USAGE CREDIT.

The WATER USAGE DEDUCTION pay item for this contract has been established with a unit of measurement in thousands of gallons (TGAL), a quantity of one-hundred (100.00), and a contract unit price of a deduction of eight dollars and eighty-five cents (\$8.85), for a total WATER USAGE DEDUCTION contract price of a deduction of eight-hundred eighty-five dollars and no cents (\$885.00). Bidder, in submitting a bid, accepts the quantity, contract unit price, and total contract price of the WATER USAGE DEDUCTION pay item.

Method of Measurement. Water usage will be measured as the actual quantity of water obtained from the Village by the Contractor, which quantity shall be rounded up to the nearest 1,000 gallons.

Basis of Payment. The water usage deduction will be deducted at the contract unit price per thousand gallons (TGAL) for WATER USAGE DEDUCTION. The quantity deducted as WATER USAGE DEDUCTION will be equal to the quantity paid for as WATER USAGE CREDIT.

PAY ITEM #42 – CONTINGENCY ALLOWANCE

Description. A contingency allowance pay item is provided as a part of this contract for the purpose of facilitating the completion of unforeseen or additional work not included in the contract as awarded, and which is determined by the Engineer to be necessary and germane to the contract.

**DCEO DRAINAGE IMPROVEMENT PROJECT (VARIOUS LOCATIONS)
VILLAGE OF VILLA PARK**

Use of the contingency allowance will be at the discretion of the Engineer. The Engineer may, at the Engineer's discretion, use the contingency allowance for any of the following reasons:

- (a) Facilitate a temporary payment allowance to the Contractor for work completed under existing contract pay items and for which completed quantities exceed contract quantities;
- (b) Facilitate a temporary payment allowance to the Contractor for work completed beyond the scope of existing contract pay items; or
- (c) Facilitate a temporary payment allowance to the Contractor for the purchase of equipment, materials or such other requisition as Engineer determines to be necessary for the completion of the Work.

Such use of the CONTINGENCY ALLOWANCE will be further subject to approval by the Village. The Village's decision with regard to use of the CONTINGENCY ALLOWANCE will be final.

- A. Any payments made to Contractor under the CONTINGENCY ALLOWANCE will be considered temporary, and will only be retained by Contractor until such time that an authorization of contract changes can be approved and incorporated into the contract.
- B. Contractor, in accepting payments made under the CONTINGENCY ALLOWANCE, agrees to the terms of this and other applicable special provisions. Contractor agrees to relinquish any monies and any claim to monies paid under the CONTINGENCY ALLOWANCE upon approval of an authorization of contract changes and payment for any work for which payment was previously made under the CONTINGENCY ALLOWANCE. Contractor further agrees to return any monies previously paid thereunder.
- C. The CONTINGENCY ALLOWANCE pay item for the Base Bid of this contract has been established with a unit of measurement in dollars, a quantity of 30,000.00, and a contract unit price of one dollar (\$1.00), for a total CONTINGENCY ALLOWANCE contract price of thirty thousand dollars and no cents (\$30,000.00). Each Alternate Bid (1 & 2) shall have a quantity of 5,000.00 and a contract unit price of one dollar (\$1.00), for a total CONTINGENCY ALLOWANCE price of five thousand dollars and no cents. Bidder, in submitting a bid, accepts the quantity, contract unit price, and total contract price of the CONTINGENCY ALLOWANCE.

Basis of Payment. This work will be paid for at the contract unit price per dollar for CONTINGENCY ALLOWANCE. The total bid amount for this item shall be as follows:

**DCEO DRAINAGE IMPROVEMENT PROJECT (VARIOUS LOCATIONS)
VILLAGE OF VILLA PARK**

Base Bid: \$30,000.00.

Alternate Bid #1: \$5,000.00

Alternate Bid #1: \$5,000.00

PAY ITEM #43 – CLEANOUTS

Description. This work shall consist of furnishing and installing a storm sewer cleanout at the locations shown in the plans or as directed by the Engineer. This work shall be in accordance with Section 560 of the Standard Specifications, the details shown on the plans and described herein.

This work consists of the installation of a storm sewer cleanout on a new storm sewer.

Materials. Storm sewer cleanout, riser pipe and fittings shall be polyvinyl chloride (PVC) of the diameter and type required.

Storm sewer cleanout shall be of the same diameter as the storm sewer line on which the cleanout is to be installed. All supplied pipe shall be from the same manufacturer.

Fittings shall include crosses, tees, bends, reducers, caps, and all other fittings as may be necessary.

Construction. The storm sewer cleanout shall be located a minimum of 12 in. behind the back of the public sidewalk. The height of the cleanout riser pipe shall be such that the top of the cleanout is ½ in. below finished grade.

Excavation, bedding, and backfilling will not be paid for separately but shall be included in the cost of this work.

Method of Measurement. This work will be measured for payment as each storm sewer cleanout installed, regardless of the depth or any other factors. No separate measurement will be made of pipe, fittings or other components.

Basis of Payment. This work will be paid for at the contract unit price per each for CLEANOUTS.

**DCEO DRAINAGE IMPROVEMENT PROJECT (VARIOUS LOCATIONS)
VILLAGE OF VILLA PARK**

PAY ITEM #44 – CLASS C PATCHES, SPECIAL

Description. This work shall consist of the removal of the existing pavement, the necessary excavation, and the replacement with Portland Cement Concrete patches at designated locations. This work shall be in accordance with Section 442 of the Standard Specifications, except as modified herein.

Remove all references to a specified type or types of patches in the Standard Specifications.

All patches shall be saw cut full-depth prior to removal of the existing pavement. Saw cuts shall be completed no more than three days prior to removal of the existing pavement. Saw cuts will not be paid for separately, but shall be included in the cost of this work.

Patches shall be constructed with 8" of Portland Cement Concrete placed on 6" subbase granular material (CA-6) in accordance with Sections 1020 and 311 of the Standard Specifications. Patches shall be installed flush with the abutting existing pavement.

The Contractor shall make every effort to minimize impacts to private driveway access. The use of steel plates will be allowed during concrete curing times, unless otherwise directed by the Engineer.

Basis of Payment. This work will be paid for at the contract unit price per square yard for CLASS C PATCHES, SPECIAL, of the thickness specified.

PAY ITEM #45 – INLET, TYPE A, 2' DIAMETER

Description. This work shall consist of constructing inlets at locations shown on the plans in accordance with the details on the plans, Section 602 of the Standard Specifications and as specified herein.

Materials. The materials shall meet the requirements of Article 602.02 of the Standard Specifications.

Construction. Structures shall be constructed in accordance with the Construction Details and Section 602 of the Standard Specifications.

The Contractor is responsible for tying in all existing storm sewers to the proposed structure. Up to 5 feet of new sewer (if required) for each existing sewer tying into the proposed structure all be considered included in the cost of this item. Connections to existing storm sewers should be made using non-shear mission couplings. The

**DCEO DRAINAGE IMPROVEMENT PROJECT (VARIOUS LOCATIONS)
VILLAGE OF VILLA PARK**

Contractor shall be responsible for verifying the size, inverts and locations of the existing sewers to be connected to the proposed structure. Any existing storm sewers that are damaged during construction shall be replaced in kind by the Contractor at no cost to the Village. The pipe, couplings, and trench back fill shall be included in the cost of the structure and will not be paid for separately.

When a proposed inlet is to be installed at the location of an existing drainage structure, the removal of the existing structure shall be included in this item.

Removing existing drainage structures shall consist of the removal and disposal of existing catch basins and inlets in accordance with Section 604 of the Standard Specifications.

Frames, grates and lids or other castings will be paid for separately.

Method of Measurement. This work will be measured for payment as each individual structure complete installed.

Basis of Payment. This work will be paid for at the contract unit price per each for INLET, TYPE A, 2' DIAMETER.

**DCEO DRAINAGE IMPROVEMENT PROJECT (VARIOUS LOCATIONS)
VILLAGE OF VILLA PARK**

APPENDIX A

VILLAGE OF VILLA PARK ORDINANCE 3733

NOT FOR BID

AN ORDINANCE OF THE VILLAGE OF VILLA PARK, DUPAGE COUNTY, ILLINOIS AMENDING THE REQUIREMENTS OF BIDDERS FOR CONSTRUCTION PROJECTS

WHEREAS, the Village of Villa Park (the “*Village*”) is a duly organized and validly existing non home-rule municipality created in accordance with the Constitution of the State of Illinois of 1970 and the laws of the State; and,

WHEREAS, section 8-9-1 of the Illinois Municipal Code (65 ILCS 5/8-9-2) allows the Village to require competitive bidding after advertising for bids in the manner prescribed by ordinance; and,

WHEREAS, the President and Board of Trustees desire to adopt purchasing procedures to provide for additional requirements of bidders for construction projects to have active apprenticeship and training programs approved and registered with the United States Department of Labor’s Bureau of Apprenticeship and Training and to have bidders show three similar projects they constructed within the last five years.

NOW, THEREFORE, BE IT ORDAINED by the President and Board of Trustees of the Village of Villa Park, DuPage County, Illinois, as follows:

Section 1. That Section 2-219 of the Villa Park Municipal Code, as amended, be and is hereby amended by placing the existing text as subsection A. and adding a new subsection B. to read as follows:

“B. A responsible bidder for the construction of public works projects shall meet and submit evidence of compliance with the following requirements:

- (1) All applicable laws prerequisite to doing business in the State of Illinois,
- (2) A federal employer tax identification number or social security number,
- (3) Provision of Section 2000(e) of Chapter 21, Title 42 of the United States Code and Federal Executive Order No. 11246 as amended by Executive Order No. 11375 (known as the Equal Opportunity Employer provisions),
- (4) Certificates of insurance indicating the following coverage’s: general liability, worker’s compensation, completed operations, automobile, hazardous occupation and product liability
- (5) Compliance with all provisions of the Illinois Prevailing Wage Act, including wages, medical and hospitalization insurance and retirement for those trades covered in the Act,
- (6) The bidder and all bidder’s sub-contractors must participate in active apprenticeship and training programs approved and registered with the United States Department of Labor’s Bureau of Apprenticeship and Training for each of the trades of work contemplated under the proposed contract,
- (7) All contractors and sub-contractors are required to file certified payrolls as specified in Illinois Pubic Act 94-0515, and follow all provisions of the Employee Classification Act (820 ILCS 185/1 et seq.), and

(8) All bidders must provide three (3) projects of a similar nature constructed in the immediate past five (5) years with the name, address and telephone number of the contact person having knowledge of the project along with three (3) references (name, address, and telephone number) with knowledge of the integrity and business practices of the bidder.”

Section 2. This Ordinance shall be in full force and effect upon its passage, approval, and publication as provided by law.

Passed this 11 day of February, 2013.

AYES: ALL

NAYS: Aiello Bulthuis

ABSENT: _____

Approved this 11 day of February, 2013.

Village President

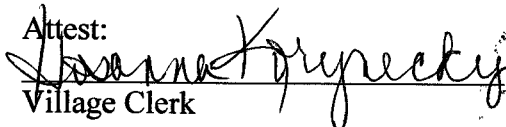
Attest:

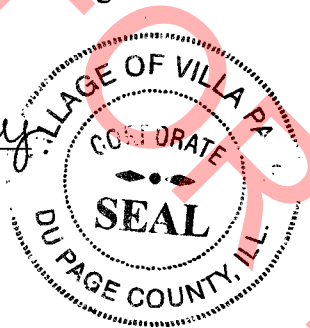
Village Clerk



Published in pamphlet form:

2-11, 2013

**DCEO DRAINAGE IMPROVEMENT PROJECT (VARIOUS LOCATIONS)
VILLAGE OF VILLA PARK**

APPENDIX B

IRMA CONTRACTUAL INSURANCE GUIDELINES

NOT FOR BID

IRMA

CONTRACTUAL INSURANCE GUIDELINES

I. INSURANCE REQUIREMENTS

Contractor shall procure and maintain, for the duration of the contract, insurance against claims for injuries to persons or damages to property, which may arise from or in connection with the performance of the work hereunder by the Contractor, his agents, representatives, employees or subcontractors.

MINIMUM SCOPE OF INSURANCE

Coverage shall be at least as broad as:

- A. Insurance Services Office Commercial General Liability occurrence form CG 0001 with the member named as additional insured, on a form at least as broad as the attached sample endorsement including ISO Additional Insured Endorsement CG 2010 (Exhibit A), CG 2026 (Exhibit B).

CG2037 - Completed Operations – (Exhibit C)

Required if box is checked ; and

- B. Owners and Contractors Protective Liability (OCP) policy with the member as insured

Required if box is checked ; and

- C. Insurance Service Office Business Auto Liability coverage form number CA 0001, Symbol 01 "Any Auto."

- D. Workers' Compensation as required by the Workers' Compensation Act of the State of Illinois and Employers' Liability insurance.

Coverage required for employee exposure to lead, if box is checked

- E. Builder Risk Property Coverage with member as loss payee

Required if box is checked .

- F. Environmental Impairment/Pollution Liability Coverage for pollution incidents as a result of a claim for bodily injury, property damage or remediation costs from an incident at, on or migrating beyond the contracted work site. Coverage shall be extended to Non-Owned Disposal sites resulting from a pollution incident at, on or mitigating beyond the site; and also provide coverage for incidents occurring during transportation of pollutants.

Required if box is checked .

MINIMUM LIMITS OF INSURANCE

Contractor shall maintain limits no less than the following, **if required under above scope**:

- A. Commercial General Liability: \$1,000,000 combined single limit per occurrence for bodily injury, and property damage and \$1,000,000 per occurrence for personal injury. The general aggregate shall be twice the required occurrence limit.

Minimum General Aggregate shall be no less than \$2,000,000 or a project/contract specific aggregate of \$1,000,000.

- B. Owners and Contractors Protective Liability (OCP): \$1,000,000 combined single limit per occurrence for bodily injury and property damage.
- C. Business Automobile Liability: \$1,000,000 combined single limit per accident for bodily injury and property damage.
- D. Workers' Compensation and Employers' Liability: Workers' Compensation coverage with statutory limits and Employers' Liability limits of \$500,000 per accident.
- E. Builder's Risk: Shall insure against "All Risk" of physical damage, including water damage (flood and hydrostatic pressure not excluded), on a completed replacement cost basis.
- F. Environmental Impairment/Pollution Liability: \$1,000,000 combined single limit per occurrence for bodily injury, property damage and remediation costs.

DEDUCTIBLES AND SELF-INSURED RETENTIONS

Any deductibles or self-insured retentions must be declared to and approved by the member. At the option of the member, either: the insurer shall reduce or eliminate such deductibles or self-insured retentions as respects the member, its officials, employees, agents and volunteers; or the Contractor shall procure a bond guaranteeing payment of losses and related investigation, claim administration and defense expenses.

OTHER INSURANCE PROVISIONS

The policies are to contain, or be endorsed to contain, the following provisions:

A. General Liability and Automobile Liability Coverages

1. The member, its officials, agents, employees and volunteers are to be covered as additional insureds as respects: liability arising out of the Contractor's work, including activities performed by or on behalf of the Contractor; products and completed operations of the Contractor; premises owned, leased or used by the Contractor; or automobiles owned, leased, hired or borrowed by the Contractor. The coverage shall contain no special limitations on the scope of protection afforded to the member, its officials, agents, employees and volunteers.
2. The Contractor's insurance coverage shall be primary as respects the member, its officials, employees, agents and volunteers. Any insurance or self-insurance maintained by the member, its officials, agents, employees and volunteers shall be excess of Contractor's insurance and shall not contribute with it.
3. Any failure to comply with reporting provisions of the policies shall not affect coverage provided to the member, its officials, employees, agents and volunteers.
4. The Contractor's insurance shall contain a Severability of Interests/Cross Liability clause or language stating that Contractor's insurance shall apply separately to each insured against whom claim is made or suit is brought,

except with respect to the limits of the insurer's liability.

5. If any commercial general liability insurance is being provided under an excess or umbrella liability policy that does not "follow form," then the Contractor shall be required to name the member, its officials, employees, agents and volunteers as additional insureds.
6. All general liability coverages shall be provided on an occurrence policy form. Claims-made general liability policies will not be accepted.
7. The contractor and all subcontractors hereby agree to waive any limitation as to the amount of contribution recoverable against them by member. This specifically includes any limitation imposed by any state statute, regulation, or case law including any Workers' Compensation Act provision that applies a limitation to the amount recoverable in contribution such as Kotecki v. Cyclops Welding.

B. Workers' Compensation and Employers' Liability Coverage

The insurer shall agree to waive all rights of subrogation against the member, its officials, employees, agents and volunteers for losses arising from work performed by Contractor for the municipality.

1. NCCI Alternate Employer Endorsement (WC 000301) in place to insure that workers' compensation coverage applies under contractor's coverage rather than member's if the member is borrowing, leasing or in day to day control of contractor's employee.

Required if box is checked .

C. Professional Liability (Required if box is checked)

1. Professional liability insurance with limits not less than \$1,000,00 each claim with respect to negligent acts, errors and omissions in connection with professional services to be provided under the contract, with a deductible not-to-exceed \$50,000 without prior written approval.
2. If the policy is written on a claims-made form, the retroactive date must be equal to or preceding the effective date of the contract. In the event the policy is cancelled, non-renewed or switched to an occurrence form, the Contractor shall be required to purchase supplemental extending reporting period coverage for a period of not less than three (3) years.
3. Provide a certified copy of actual policy for review.
4. Recommended Required Coverage (architect, engineer, surveyor, consultant): Professional liability insurance that provides indemnification and defense for injury or damage arising out of acts, errors, or omissions in providing the following professional services, but not limited to the following:
 - a. Preparing, approving or failure to prepare or approve maps, drawings, opinions, report, surveys, change orders, designs or specifications;
 - b. Providing direction, instruction, supervision, inspection, engineering services

or failing to provide them, if that is the primary cause of injury or damage.

D. All Coverages

Each insurance policy required shall have the member expressly endorsed onto the policy as a Cancellation Notice Recipient. Should any of the policies be cancelled before the expiration date thereof, notice will be delivered in accordance with the policy provisions.

ACCEPTABILITY OF INSURERS

Insurance is to be placed with insurers with a Best's rating of no less than A-, VII and licensed to do business in the State of Illinois.

VERIFICATION OF COVERAGE

Contractor shall furnish the member with certificates of insurance naming the member, its officials, employees, agents and volunteers as additional insureds (Exhibit D), and with original endorsements affecting coverage required by this clause. The certificates and endorsements for each insurance policy are to be signed by a person authorized by that insurer to bind coverage on its behalf. The certificates and endorsements are to be received and approved by the member before any work commences. The following additional insured endorsements may be utilized: ISO Additional Insured Endorsements CG 2010 (Exhibit A) or CG 2026 (Exhibit B), and CG 2037 (Exhibit C) – Completed Operations, where required. The member reserves the right to request full certified copies of the insurance policies and endorsements.

SUBCONTRACTORS

Contractor shall include all subcontractors as insureds under its policies or shall furnish separate certificates and endorsements for each subcontractor. All coverages for subcontractors shall be subject to all of the requirements stated herein.

ASSUMPTION OF LIABILITY

The contractor assumes liability for all injury to or death of any person or persons including employees of the contractor, any sub-contractor, any supplier or any other person and assumes liability for all damage to property sustained by any person or persons occasioned by or in any way arising out of any work performed pursuant to this agreement.

II. INDEMNITY/HOLD HARMLESS PROVISION

To the fullest extent permitted by law, the Contractor hereby agrees to defend, indemnify and hold harmless the member, its officials, employees and agents against all injuries, deaths, loss, damages, claims, patent claims, suits, liabilities, judgments, cost and expenses, which may in anywise accrue against the member, its officials, agents and employees, arising in whole or in part or in consequence of the performance of this work by the Contractor, its employees, or subcontractors, or which may in anywise result therefore, except that arising out of the sole legal cause of the member, its employees or agents, the Contractor shall, at its own expense, appear, defend and pay all charges of attorneys and all costs and other expenses arising therefore or incurred in connections therewith, and, if any judgment shall be rendered against the member, its officials, employees and agents, in

any such action, the Contractor shall, at its own expense, satisfy and discharge the same.

Contractor expressly understands and agrees that any performance bond or insurance policies required by this contract, or otherwise provided by the Contractor, shall in no way limit the responsibility to indemnify, keep and save harmless and defend the member, its officials, employees and agents as herein provided.

The Contractor further agrees that to the extent that money is due the Contractor by virtue of this contract as shall be considered necessary in the judgment of the member, may be retained by the member to protect itself against said loss until such claims, suits, or judgments shall have been settled or discharged and/or evidence to that effect shall have been furnished to the satisfaction of the member.

III. SAFETY/LOSS PREVENTION

Safety/Loss Prevention Program Requirements

- Successful bidder will provide written confirmation that a safety/loss prevention program was in place at least 90 days prior to submitting the bid proposal.
- Evidence of completed employee safety training can be provided.

Regulatory Requirements

- Successful bidder must comply with all applicable laws, regulations, and rules promulgated by any Federal, State, County, Municipal and/or other governmental unit or regulatory body now in effect or which may be in effect during the performance of the work. Included within the scope of the laws, regulations, and rules referred to in this paragraph but in no way to operate as a limitation, are Occupational Safety & Health Act (OSHA), Illinois Department of Labor (IDOL), Department of Transportation, all forms of traffic regulations, public utility, Intrastate and Interstate Commerce Commission regulations, Workers' Compensation Laws, Prevailing Wage Laws, the Social Security Act of the Federal Government and any of its titles, the Illinois Department of Human Rights, Human Rights Commission, or EEOC statutory provisions and rules and regulations.
- Evidence of specific regulatory compliance will be provided by bidder, if required by owner.

EXHIBIT A

POLICY NUMBER:

COMMERCIAL GENERAL LIABILITY
CG 20 10 07 04

THIS ENDORSEMENT CHANGES THE POLICY. PLEASE READ IT CAREFULLY.

**ADDITIONAL INSURED – OWNERS, LESSEES OR
CONTRACTORS – SCHEDULED PERSON OR
ORGANIZATION**

This endorsement modifies insurance provided under the following:

COMMERCIAL GENERAL LIABILITY COVERAGE PART

SCHEDULE

Name Of Additional Insured Person(s) Or Organization(s):	Location(s) Of Covered Operations
Information required to complete this Schedule, if not shown above, will be shown in the Declarations.	

A. Section II – Who Is An Insured is amended to include as an additional insured the person(s) or organization(s) shown in the Schedule, but only with respect to liability for "bodily injury," "property damage" or "personal and advertising injury" caused, in whole or in part, by:

1. Your acts or omissions; or
2. The acts or omissions of those acting on your behalf;

in the performance of your ongoing operations for the additional insured(s) at the location(s) designated above.

B. With respect to the insurance afforded to these additional insureds, the following additional exclusions apply:

This insurance does not apply to "bodily injury" or "property damage" occurring after:

1. All work, including materials, parts or equipment furnished in connection with such work, on the project (other than service, maintenance or repairs) to be performed by or on behalf of the additional insured(s) at the location of the covered operations has been completed; or
2. That portion of "your work" out of which the injury or damage arises has been put to its intended use by any person or organization other than another contractor or subcontractor engaged in performing operations for a principal as a part of the same project.

EXHIBIT C

POLICY NUMBER:

COMMERCIAL GENERAL LIABILITY
CG 20 37 07 04

THIS ENDORSEMENT CHANGES THE POLICY. PLEASE READ IT CAREFULLY.

**ADDITIONAL INSURED – OWNERS, LESSEES OR
CONTRACTORS – COMPLETED OPERATIONS**

This endorsement modifies insurance provided under the following:

COMMERCIAL GENERAL LIABILITY COVERAGE PART

SCHEDULE

Name Of Additional Insured Person(s) Or Organization(s):	Location And Description Of Completed Operations
Information required to complete this Schedule, if not shown above, will be shown in the Declarations.	

Section II – Who Is An Insured is amended to include as an additional insured the person(s) or organization(s) shown in the Schedule, but only with respect to liability for "bodily injury" or "property damage" caused, in whole or in part, by "your work" at the location designated and described in the schedule of this endorsement performed for that additional insured and included in the "products-completed operations hazard".



Exhibit D (Example)

CERTIFICATE OF LIABILITY INSURANCE

DATE (MM/DD/YYYY)

THIS CERTIFICATE IS ISSUED AS A MATTER OF INFORMATION ONLY AND CONFERS NO RIGHTS UPON THE CERTIFICATE HOLDER. THIS CERTIFICATE DOES NOT AFFIRMATIVELY OR NEGATIVELY AMEND, EXTEND OR ALTER THE COVERAGE AFFORDED BY THE POLICIES BELOW.

IMPORTANT: If the certificate holder is an ADDITIONAL INSURED, the policy(ies) must be endorsed. If SUBROGATION IS WAIVED, subject to the terms and conditions of the policy, certain policies may require an endorsement.

PRODUCER: Name of Insurance Broker; CONTACT NAME: Producer/Ins. Broker Contact Info.; INSURER(S) AFFORDING COVERAGE: Name of Insurance Company; NAIC #: Completed

COVERAGES CERTIFICATE NUMBER: REVISION NUMBER:

THIS IS TO CERTIFY THAT THE POLICIES OF INSURANCE LISTED BELOW HAVE BEEN ISSUED TO THE INSURED NAMED ABOVE FOR THE POLICY PERIOD INDICATED. NOTWITHSTANDING ANY REQUIREMENT, TERM OR CONDITION OF ANY CONTRACT OR OTHER DOCUMENT WITH RESPECT TO WHICH THIS CERTIFICATE MAY BE ISSUED OR MAY PERTAIN, THE INSURANCE AFFORDED BY THE POLICIES DESCRIBED HEREIN IS SUBJECT TO ALL THE TERMS, EXCLUSIONS AND CONDITIONS OF SUCH POLICIES.

Table with columns: INSR LTR, TYPE OF INSURANCE, ADDL INSR, SUBR WVD, POLICY NUMBER, POLICY EFF, POLICY EXP, LIMITS. Rows include General Liability, Automobile Liability, Umbrella Liab, Workers Compensation and Employers' Liability, and Professional Liability.

DESCRIPTION OF OPERATIONS / LOCATIONS / VEHICLES (Attach ACORD 101, Additional Remarks Schedule, if more space is required) List project number, location and description. No additional endorsements limit coverage to additional insured beyond terms of actual additional insured endorsement (CG 2010 or CG 2026).

CERTIFICATE HOLDER: Name of Member; CANCELLATION: SHOULD ANY OF THE ABOVE DESCRIBED POLICIES BE CANCELLED BEFORE THE EXPIRATION DATE THEREOF, NOTICE WILL BE DELIVERED IN ACCORDANCE WITH THE POLICY PROVISIONS.

**DCEO DRAINAGE IMPROVEMENT PROJECT (VARIOUS LOCATIONS)
VILLAGE OF VILLA PARK**

APPENDIX C

INDEX FOR SUPPLEMENTAL SPECIFICATIONS AND RECURRING SPECIAL PROVISIONS

CHECK SHEET FOR RECURRING SPECIAL PROVISIONS

CHECK SHEET FOR LOCAL ROADS & STREETS RECURRING SPECIAL PROVISIONS

BDE SPECIAL PROVISIONS

SPECIAL PROVISION FOR INSURANCE (LR 107-4)

SPECIAL PROVISION FOR EQUIPMENT RENTAL RATES (LR 109)

NOT FOR BID

INDEX
FOR
SUPPLEMENTAL SPECIFICATIONS
AND RECURRING SPECIAL PROVISIONS

Adopted January 1, 2025

This index contains a listing of SUPPLEMENTAL SPECIFICATIONS, frequently used RECURRING SPECIAL PROVISIONS, and LOCAL ROADS AND STREETS RECURRING SPECIAL PROVISIONS.

ERRATA Standard Specifications for Road and Bridge Construction
(Adopted 1-1-22) (Revised 1-1-25)

SUPPLEMENTAL SPECIFICATIONS

<u>Std. Spec. Sec.</u>	<u>Page No.</u>
202 Earth and Rock Excavation	1
204 Borrow and Furnished Excavation	2
207 Porous Granular Embankment	3
211 Topsoil and Compost	4
406 Hot-Mix Asphalt Binder and Surface Course	5
407 Hot-Mix Asphalt Pavement (Full-Depth)	7
420 Portland Cement Concrete Pavement	8
502 Excavation for Structures	9
509 Metal Railings	10
540 Box Culverts	11
542 Pipe Culverts	31
550 Storm Sewers	40
586 Granular Backfill for Structures	47
630 Steel Plate Beam Guardrail	48
632 Guardrail and Cable Road Guard Removal	49
644 High Tension Cable Median Barrier	50
665 Woven Wire Fence	51
701 Work Zone Traffic Control and Protection	52
781 Raised Reflective Pavement Markers	54
782 Reflectors	55
801 Electrical Requirements	57
821 Roadway Luminaires	60
1003 Fine Aggregates	61
1004 Coarse Aggregates	62
1010 Finely Divided Minerals	63
1020 Portland Cement Concrete	64
1030 Hot-Mix Asphalt	67
1040 Drain Pipe, Tile, and Wall Drain	68
1061 Waterproofing Membrane System	69
1067 Luminaire	70
1097 Reflectors	77
1102 Hot-Mix Asphalt Equipment	78

Check Sheet for Recurring Special Provisions

Local Public Agency	County	Section Number
Village of Villa Park	DuPage	

Check this box for lettings prior to 01/01/2025

The Following Recurring Special Provisions Indicated By An "X" Are Applicable To This Contract And Are Included By Reference:

Recurring Special Provisions

<u>Check Sheet #</u>		<u>Page No.</u>
1	<input type="checkbox"/> Additional State Requirements for Federal-Aid Construction Contracts	79
2	<input type="checkbox"/> Subletting of Contracts (Federal-Aid Contracts)	82
3	<input type="checkbox"/> EEO	83
4	<input type="checkbox"/> Specific EEO Responsibilities Non Federal-Aid Contracts	93
5	<input type="checkbox"/> Required Provisions - State Contracts	98
6	<input type="checkbox"/> Asbestos Bearing Pad Removal	104
7	<input type="checkbox"/> Asbestos Waterproofing Membrane and Asbestos HMA Surface Removal	105
8	<input type="checkbox"/> Temporary Stream Crossings and In-Stream Work Pads	106
9	<input checked="" type="checkbox"/> Construction Layout Stakes	107
10	<input type="checkbox"/> Use of Geotextile Fabric for Railroad Crossing	110
11	<input type="checkbox"/> Subsealing of Concrete Pavements	112
12	<input type="checkbox"/> Hot-Mix Asphalt Surface Correction	116
13	<input type="checkbox"/> Pavement and Shoulder Resurfacing	118
14	<input type="checkbox"/> Patching with Hot-Mix Asphalt Overlay Removal	119
15	<input type="checkbox"/> Polymer Concrete	121
16	<input type="checkbox"/> Reserved	123
17	<input type="checkbox"/> Bicycle Racks	124
18	<input type="checkbox"/> Temporary Portable Bridge Traffic Signals	126
19	<input type="checkbox"/> Nighttime Inspection of Roadway Lighting	128
20	<input type="checkbox"/> English Substitution of Metric Bolts	129
21	<input type="checkbox"/> Calcium Chloride Accelerator for Portland Cement Concrete	130
22	<input type="checkbox"/> Quality Control of Concrete Mixtures at the Plant	131
23	<input checked="" type="checkbox"/> Quality Control/Quality Assurance of Concrete Mixtures	139
24	<input type="checkbox"/> Reserved	155
25	<input type="checkbox"/> Reserved	156
26	<input type="checkbox"/> Temporary Raised Pavement Markers	157
27	<input type="checkbox"/> Restoring Bridge Approach Pavements Using High-Density Foam	158
28	<input type="checkbox"/> Portland Cement Concrete Inlay or Overlay	161
29	<input type="checkbox"/> Portland Cement Concrete Partial Depth Hot-Mix Asphalt Patching	165
30	<input type="checkbox"/> Longitudinal Joint and Crack Patching	168
31	<input type="checkbox"/> Concrete Mix Design - Department Provided	170
32	<input type="checkbox"/> Station Numbers in Pavements or Overlays	171

Village of Villa Park

DuPage

The Following Local Roads And Streets Recurring Special Provisions Indicated By An "X" Are Applicable To This Contract And Are Included By Reference:

Local Roads And Streets Recurring Special Provisions

<u>Check Sheet #</u>		<u>Page No.</u>
LRS 1	Reserved	173
LRS 2	<input type="checkbox"/> Furnished Excavation	174
LRS 3	<input checked="" type="checkbox"/> Work Zone Traffic Control Surveillance	175
LRS 4	<input checked="" type="checkbox"/> Flaggers in Work Zones	176
LRS 5	<input type="checkbox"/> Contract Claims	177
LRS 6	<input type="checkbox"/> Bidding Requirements and Conditions for Contract Proposals	178
LRS 7	<input type="checkbox"/> Bidding Requirements and Conditions for Material Proposals	184
LRS 8	Reserved	190
LRS 9	<input type="checkbox"/> Bituminous Surface Treatments	191
LRS 10	Reserved	195
LRS 11	<input type="checkbox"/> Employment Practices	196
LRS 12	<input type="checkbox"/> Wages of Employees on Public Works	198
LRS 13	<input type="checkbox"/> Selection of Labor	200
LRS 14	<input type="checkbox"/> Paving Brick and Concrete Paver Pavements and Sidewalks	201
LRS 15	<input type="checkbox"/> Partial Payments	204
LRS 16	<input type="checkbox"/> Protests on Local Lettings	205
LRS 17	<input type="checkbox"/> Substance Abuse Prevention Program	206
LRS 18	<input type="checkbox"/> Multigrade Cold Mix Asphalt	207
LRS 19	<input type="checkbox"/> Reflective Crack Control Treatment	208

BDE SPECIAL PROVISIONS
For the January 17 and March 7, 2025 Lettings

The following special provisions indicated by a "check mark" are applicable to this contract and will be included by the Project Coordination and Implementation Section of the Bureau of Design & Environment (BDE).

File Name	#		Special Provision Title	Effective	Revised	
	80099	1	<input type="checkbox"/>	Accessible Pedestrian Signals (APS)	April 1, 2003	Jan. 1, 2022
	80274	2	<input type="checkbox"/>	Aggregate Subgrade Improvement	April 1, 2012	April 1, 2022
	80192	3	<input type="checkbox"/>	Automated Flagger Assistance Devices	Jan. 1, 2008	April 1, 2023
	80173	4	<input type="checkbox"/>	Bituminous Materials Cost Adjustments	Nov. 2, 2006	Aug. 1, 2017
	80426	5	<input type="checkbox"/>	Bituminous Surface Treatment with Fog Seal	Jan. 1, 2020	Jan. 1, 2022
*	80241	6	<input type="checkbox"/>	Bridge Demolition Debris	July 1, 2009	
*	50531	7	<input type="checkbox"/>	Building Removal	Sept. 1, 1990	Aug. 1, 2022
*	50261	8	<input type="checkbox"/>	Building Removal with Asbestos Abatement	Sept. 1, 1990	Aug. 1, 2022
	80460	9	<input type="checkbox"/>	Cement, Finely Divided Minerals, Admixtures, Concrete, and Mortar	Jan. 1, 2025	
	80384	10	<input type="checkbox"/>	Compensable Delay Costs	June 2, 2017	April 1, 2019
*	80198	11	<input type="checkbox"/>	Completion Date (via calendar days)	April 1, 2008	
*	80199	12	<input type="checkbox"/>	Completion Date (via calendar days) Plus Working Days	April 1, 2008	
	80461	13	<input type="checkbox"/>	Concrete Barrier	Jan. 1, 2025	
	80453	14	<input type="checkbox"/>	Concrete Sealer	Nov. 1, 2023	
	80261	15	<input checked="" type="checkbox"/>	Construction Air Quality – Diesel Retrofit	June 1, 2010	Jan. 1, 2025
*	80029	16	<input type="checkbox"/>	Disadvantaged Business Enterprise Participation	Sept. 1, 2000	Mar. 2, 2019
	80229	17	<input type="checkbox"/>	Fuel Cost Adjustment	April 1, 2009	Aug. 1, 2017
	80452	18	<input type="checkbox"/>	Full Lane Sealant Waterproofing System	Nov. 1, 2023	
	80447	19	<input checked="" type="checkbox"/>	Grading and Shaping Ditches	Jan. 1, 2023	
	80433	20	<input type="checkbox"/>	Green Preformed Thermoplastic Pavement Markings	Jan. 1, 2021	Jan. 1, 2022
	80456	21	<input checked="" type="checkbox"/>	Hot-Mix Asphalt	Jan. 1, 2024	Jan. 1, 2025
	80446	22	<input type="checkbox"/>	Hot-Mix Asphalt - Longitudinal Joint Sealant	Nov. 1, 2022	Aug. 1, 2023
	80438	23	<input type="checkbox"/>	Illinois Works Apprenticeship Initiative – State Funded Contracts	June 2, 2021	April 2, 2024
	80450	24	<input type="checkbox"/>	Mechanically Stabilized Earth Retaining Walls	Aug. 1, 2023	
	80441	25	<input type="checkbox"/>	Performance Graded Asphalt Binder	Jan. 1, 2023	
	80459	26	<input type="checkbox"/>	Preformed Plastic Pavement Marking	June 2, 2024	
*	34261	27	<input type="checkbox"/>	Railroad Protective Liability Insurance	Dec. 1, 1986	Jan. 1, 2022
	80455	28	<input type="checkbox"/>	Removal and Disposal of Regulated Substances	Jan. 1, 2024	April 1, 2024
	80445	29	<input type="checkbox"/>	Seeding	Nov. 1, 2022	
	80457	30	<input type="checkbox"/>	Short Term and Temporary Pavement Markings	April 1, 2024	April 2, 2024
	80462	31	<input type="checkbox"/>	Sign Panels and Appurtenances	Jan. 1, 2025	
	80448	32	<input type="checkbox"/>	Source of Supply and Quality Requirements	Jan. 2, 2023	
	80340	33	<input type="checkbox"/>	Speed Display Trailer	April 2, 2014	Jan. 1, 2022
	80127	34	<input type="checkbox"/>	Steel Cost Adjustment	April 2, 2004	Jan. 1, 2022
	80397	35	<input type="checkbox"/>	Subcontractor and DBE Payment Reporting	April 2, 2018	
	80391	36	<input type="checkbox"/>	Subcontractor Mobilization Payments	Nov. 2, 2017	April 1, 2019
	80437	37	<input type="checkbox"/>	Submission of Payroll Records	April 1, 2021	Nov. 2, 2023
	80435	38	<input type="checkbox"/>	Surface Testing of Pavements – IRI	Jan. 1, 2021	Jan. 1, 2023
*	20338	39	<input type="checkbox"/>	Training Special Provisions	Oct. 15, 1975	Sept. 2, 2021
	80429	40	<input type="checkbox"/>	Ultra-Thin Bonded Wearing Course	April 1, 2020	Jan. 1, 2022
	80439	41	<input type="checkbox"/>	Vehicle and Equipment Warning Lights	Nov. 1, 2021	Nov. 1, 2022
	80458	42	<input type="checkbox"/>	Waterproofing Membrane System	Aug. 1, 2024	
	80302	43	<input type="checkbox"/>	Weekly DBE Trucking Reports	June 2, 2012	Nov. 1, 2021
	80454	44	<input type="checkbox"/>	Wood Sign Support	Nov. 1, 2023	
	80427	45	<input checked="" type="checkbox"/>	Work Zone Traffic Control Devices	Mar. 2, 2020	Jan. 1, 2025
*	80071	46	<input type="checkbox"/>	Working Days	Jan. 1, 2002	

Highlighted items indicate a new or revised special provision for the letting.

An * indicates the special provision requires additional information from the designer, which needs to be submitted separately. The Project Coordination and Implementation Section will then include the information in the applicable special provision.

The following special provisions have been deleted from use.

<u>File Name</u>	<u>Special Provision Title</u>	<u>Effective</u>	<u>Revised</u>
80449	Cement, Type IL	Aug. 1, 2023	
80451	Portland Cement Concrete	Aug. 1, 2023	

The following special provisions are in the 2025 Supplemental Specifications and Recurring Special Provisions.

<u>File Name</u>	<u>Special Provision Title</u>	<u>New Location(s)</u>	<u>Effective</u>	<u>Revised</u>
80434	Corrugated Plastic Pipe (Culvert and Storm Sewer)	Articles 542.03, 550.03, 1040.03, 1040.04(b), 1040.04(d) & 1040.08	Jan. 1, 2021	
80443	High Tension Cable Median Barrier Removal	Section 632	April 1, 2022	
80045	Material Transfer Device	Articles 406.03, 406.06(f), 406.13(b), 406.14 & 1102.02	Nov 15, 1999	Jan. 1, 2022
80410	Traffic Spotters	Article 701.13	Jan. 1, 2019	

NOT FOR BID

CONSTRUCTION AIR QUALITY – DIESEL RETROFIT (BDE)

Effective: June 1, 2010

Revised: January 1, 2025

The reduction of emissions of particulate matter (PM) for off-road equipment shall be accomplished by installing retrofit emission control devices. The term “equipment” refers to diesel fuel powered devices rated at 50 hp and above, to be used on the jobsite in excess of seven calendar days over the course of the construction period on the jobsite (including rental equipment).

Contractor and subcontractor diesel powered off-road equipment assigned to the contract shall be retrofitted according to the table below.

Horsepower Range	Model Year and Older
50-99	2003
100-299	2002
300-599	2000
600-749	2001
750 and up	2005

The retrofit emission control devices shall achieve a minimum PM emission reduction of 50 percent and shall be:

- a) Included on the U.S. Environmental Protection Agency (USEPA) *Verified Retrofit Technology List* (<https://www.epa.gov/verified-diesel-tech/verified-technologies-list-clean-diesel>), or verified by the California Air Resources Board (CARB) (<http://www.arb.ca.gov/diesel/verdev/vt/cvt.htm>); or
- b) Retrofitted with a non-verified diesel retrofit emission control device if verified retrofit emission control devices are not available for equipment proposed to be used on the project, and if the Contractor has obtained a performance certification from the retrofit device manufacturer that the emission control device provides a minimum PM emission reduction of 50 percent.

Note: Large cranes (Crawler mounted cranes) which are responsible for critical lift operations are exempt from installing retrofit emission control devices if such devices adversely affect equipment operation.

Diesel powered off-road equipment with engine ratings of 50 hp and above, which are unable to be retrofitted with verified emission control devices or if performance certifications are not available which will achieve a minimum 50 percent PM reduction, may be granted a waiver by the Department if documentation is provided showing good faith efforts were made by the Contractor to retrofit the equipment.

Construction shall not proceed until the Contractor submits a certified list of the diesel powered off-road equipment that will be used, and as necessary, retrofitted with emission control devices. The list(s) shall include (1) the equipment number, type, make, Contractor/rental company name; and (2) the emission control devices make, model, USEPA or CARB verification number, or performance certification from the retrofit device manufacturer. Equipment reported as fitted with emissions control devices shall be made available to the Engineer for visual inspection of the device installation, prior to being used on the jobsite.

The Contractor shall submit an updated list of retrofitted off-road construction equipment as retrofitted equipment changes or comes on to the jobsite. The addition or deletion of any diesel powered equipment shall be included on the updated list.

If any diesel powered off-road equipment is found to be in non-compliance with any portion of this special provision, the Engineer will issue the Contractor a diesel retrofit deficiency deduction.

Any costs associated with retrofitting any diesel powered off-road equipment with emission control devices shall be considered as included in the contract unit prices bid for the various items of work involved and no additional compensation will be allowed. The Contractor's compliance with this notice and any associated regulations shall not be grounds for a claim.

Diesel Retrofit Deficiency Deduction

When the Engineer determines that a diesel retrofit deficiency exists, a daily monetary deduction will be imposed for each calendar day or fraction thereof the deficiency continues to exist. The calendar day(s) will begin when the time period for correction is exceeded and end with the Engineer's written acceptance of the correction. The daily monetary deduction will be \$1,000.00 for each deficiency identified.

The deficiency will be based on lack of diesel retrofit emissions control.

If a Contractor accumulates three diesel retrofit deficiency deductions for the same piece of equipment in a contract period, the Contractor will be shutdown until the deficiency is corrected. Such a shutdown will not be grounds for any extension of the contract time, waiver of penalties, or be grounds for any claim.

GRADING AND SHAPING DITCHES (BDE)

Effective: January 1, 2023

Delete the second paragraph of Article 214.03 of the Standard Specifications.

Delete the second paragraph of Article 214.04 of the Standard Specifications.

80447

NOT FOR BID

HOT-MIX ASPHALT (BDE)

Effective: January 1, 2024

Revised: January 1, 2025

Revise the first and second paragraphs of Articles 1030.06(c)(2) of the Standard Specifications to read:

“(2) Personnel. The Contractor shall provide a QC Manager who shall have overall responsibility and authority for quality control. This individual shall maintain active certification as a Hot-Mix Asphalt Level II technician.

In addition to the QC Manager, the Contractor shall provide sufficient personnel to perform the required visual inspections, sampling, testing, and documentation in a timely manner. Mix designs shall be developed by personnel with an active certification as a Hot-Mix Asphalt Level III technician. Technicians performing mix design testing and plant sampling/testing shall maintain active certification as a Hot-Mix Asphalt Level I technician. The Contractor may provide a technician trainee who has successfully completed the Department's "Hot-Mix Asphalt Trainee Course" to assist in the activities completed by a Hot-Mix Asphalt Level I technician for a period of one year after the course completion date. The Contractor may also provide a Gradation Technician who has successfully completed the Department's "Gradation Technician Course" to run gradation tests only under the supervision of a Hot-Mix Asphalt Level II Technician. The Contractor shall provide a Hot-Mix Asphalt Density Tester who has successfully completed the Department's "Nuclear Density Testing" course to run all nuclear density tests on the job site.”

Revise the second paragraph of Articles 1030.07(a)(11) and 1030.08(a)(9) of the Standard Specifications to read:

“When establishing the target density, the HMA maximum theoretical specific gravity (G_{mm}) will be based on the running average of four available Department test results for that project. If less than four G_{mm} test results are available, an average of all available Department test results for that project will be used. The initial G_{mm} will be the last available Department test result from a QMP project. If there is no available Department test result from a QMP project, the Department mix design verification test result will be used as the initial G_{mm} .”

Revise Article 1030.09(g)(2) of the Standard Specifications to read:

“(2) The Contractor shall complete split verification sample tests listed in the Limits of Precision table in Article 1030.09(h)(1).”

In the Supplemental Specifications, replace the revision for the end of the third paragraph of Article 1030.09(h)(2) with the following:

“When establishing the target density, the HMA maximum theoretical specific gravity (G_{mm}) will be the Department mix design verification test result.”

Revise the tenth paragraph of Article 1030.10 of the Standard Specifications to read:

“Production is not required to stop after a test strip has been constructed.”

80456

NOT FOR BID

WORK ZONE TRAFFIC CONTROL DEVICES (BDE)

Effective: March 2, 2020

Revised: January 1, 2025

Add the following to Article 701.03 of the Standard Specifications:

“(q) Temporary Sign Supports 1106.02”

Revise the third paragraph of Article 701.14 of the Standard Specifications to read:

“For temporary sign supports, the Contractor shall provide a FHWA eligibility letter for each device used on the contract. The letter shall provide information for the set-up and use of the device as well as a detailed drawing of the device. The signs shall be supported within 20 degrees of vertical. Weights used to stabilize signs shall be attached to the sign support per the manufacturer’s specifications.”

Revise the first paragraph of Article 701.15 of the Standard Specifications to read:

“**701.15 Traffic Control Devices.** For devices that must meet crashworthiness standards, the Contractor shall provide a manufacturer’s self-certification or a FHWA eligibility letter for each Category 1 device and a FHWA eligibility letter for each Category 2 and Category 3 device used on the contract. The self-certification or letter shall provide information for the set-up and use of the device as well as a detailed drawing of the device.”

Revise the first six paragraphs of Article 1106.02 of the Standard Specifications to read:

“**1106.02 Devices.** Work zone traffic control devices and combinations of devices shall meet crashworthiness standards for their respective categories. The categories are as follows.

Category 1 includes small, lightweight, channelizing and delineating devices that have been in common use for many years and are known to be crashworthy by crash testing of similar devices or years of demonstrable safe performance. These include cones, tubular markers, plastic drums, and delineators, with no attachments (e.g. lights). Category 1 devices shall be MASH compliant.

Category 2 includes devices that are not expected to produce significant vehicular velocity change but may otherwise be hazardous. These include vertical panels with lights, barricades, temporary sign supports, and Category 1 devices with attachments (e.g. drums with lights). Category 2 devices shall be MASH compliant.

Category 3 includes devices that are expected to cause significant velocity changes or other potentially harmful reactions to impacting vehicles. These include crash cushions (impact attenuators), truck mounted attenuators, and other devices not meeting the definitions of Category 1 or 2. Category 3 devices manufactured after December 31, 2019 shall be MASH compliant. Category 3 devices manufactured on or before December 31, 2019, and compliant

with NCHRP 350, may be used on contracts let before December 31, 2029. Category 3 devices shall be crash tested for Test Level 3 or the test level specified.

Category 4 includes portable or trailer-mounted devices such as sign supports, speed feedback displays, arrow boards, changeable message signs, temporary traffic signals, and area lighting supports. It is preferable for Category 4 devices manufactured after December 31, 2019 to be MASH-16 compliant; however, there are currently no crash tested devices in this category, so it remains exempt from the NCHRP 350 or MASH compliance requirement.

For each type of device, when no more than one MASH compliant is available, an NCHRP 350 compliant device may be used, even if manufactured after December 31, 2019.”

Revise Articles 1106.02(g), 1106.02(k), and 1106.02(l) to read:

“(g) Truck Mounted/Trailer Mounted Attenuators. The attenuator shall be approved for use at Test Level 3. Test Level 2 may be used for normal posted speeds less than or equal to 45 mph.

(k) Temporary Water Filled Barrier. The water filled barrier shall be a lightweight plastic shell designed to accept water ballast and be on the Department’s qualified product list.

Shop drawings shall be furnished by the manufacturer and shall indicate the deflection of the barrier as determined by acceptance testing; the configuration of the barrier in that test; and the vehicle weight, velocity, and angle of impact of the deflection test. The Engineer shall be provided one copy of the shop drawings.

(l) Movable Traffic Barrier. The movable traffic barrier shall be on the Department’s qualified product list.

Shop drawings shall be furnished by the manufacturer and shall indicate the deflection of the barrier as determined by acceptance testing; the configuration of the barrier in that test; and the vehicle weight, velocity, and angle of impact of the deflection test. The Engineer shall be provided one copy of the shop drawings. The barrier shall be capable of being moved on and off the roadway on a daily basis.”

State of Illinois
Department of Transportation
Bureau of Local Roads and Streets

SPECIAL PROVISION
FOR
INSURANCE

Effective: February 1, 2007
Revised: August 1, 2007

All references to Sections or Articles in this specification shall be construed to mean specific Section or Article of the Standard Specifications for Road and Bridge Construction, adopted by the Department of Transportation.

The Contractor shall name the following entities as additional insured under the Contractor's general liability insurance policy in accordance with Article 107.27:

Village of Villa Park

The entities listed above and their officers, employees, and agents shall be indemnified and held harmless in accordance with Article 107.26.

State of Illinois
Department of Transportation
Bureau of Local Roads and Streets

SPECIAL PROVISION
FOR
EQUIPMENT RENTAL RATES

Effective: January 1, 2012

All references to Sections or Articles in this specification shall be construed to mean a specific Section or Article of the Standard Specifications for Road and Bridge Construction, adopted by the Department of Transportation.

Replace Article 109.04(b)(4) with the following:

- "(4) Equipment. For any machinery or special equipment (other than small tools) the use of which has been authorized by the Engineer, the Contractor will be paid according to the latest revision of "SCHEDULE OF AVERAGE ANNUAL EQUIPMENT OWNERSHIP EXPENSE" and latest index factor as issued by the Illinois Department of Transportation. The equipment should be of a type and size reasonably required to complete the extra work."

**DCEO DRAINAGE IMPROVEMENT PROJECT (VARIOUS LOCATIONS)
VILLAGE OF VILLA PARK**

APPENDIX D

DUPAGE COUNTY PREVAILING WAGE RATES

NOT FOR BID

DuPage County Prevailing Wage Rates posted on 12/16/2024

Trade Title	Rg	Type	C	Base	Foreman	Overtime					Pension	Vac	Trng	Other Ins	Add OT 1.5x owed	Add OT 2.0x owed
						M-F	Sa	Su	Hol	H/W						
ASBESTOS ABT-GEN	All	ALL		50.15	51.15	1.5	1.5	2.0	2.0	17.71	16.92	0.00	0.91		0.00	0.00
ASBESTOS ABT-MEC	All	BLD		41.27	44.57	1.5	1.5	2.0	2.0	15.84	16.02	0.00	0.90		3.11	6.21
BOILERMAKER	All	BLD		55.76	60.77	2.0	2.0	2.0	2.0	6.97	26.44	0.00	3.34	1.95	0.00	38.26
BRICK MASON	All	BLD		52.06	57.27	1.5	1.5	2.0	2.0	12.70	24.54	0.00	1.24	0.00	3.99	7.98
CARPENTER	All	ALL		55.11	57.11	1.5	1.5	2.0	2.0	12.89	26.26	2.15	0.93	0.00	0.00	0.00
CEMENT MASON	All	ALL		52.00	54.00	2.0	1.5	2.0	2.0	17.81	23.00	0.00	1.15		2.00	4.00
CERAMIC TILE FINISHER	All	BLD		47.09	47.09	1.5	1.5	2.0	2.0	13.00	16.82	0.00	1.09	0.00	5.17	10.34
CERAMIC TILE LAYER	All	BLD		54.84	59.84	1.5	1.5	2.0	2.0	13.00	20.68	0.00	1.17	0.00	7.15	14.30
COMMUNICATION TECHNICIAN	All	BLD		39.35	42.15	1.5	1.5	2.0	2.0	14.65	24.59	3.20	0.83	0.00	14.32	28.62
ELECTRIC PWR EQMT OP	All	ALL		50.82	69.34	1.5	1.5	2.0	2.0	7.25	14.22	0.00	1.52	1.52	8.63	17.26
ELECTRIC PWR GRNDMAN	All	ALL		39.04	69.34	1.5	1.5	2.0	2.0	7.25	10.93	0.00	1.17	1.17	6.63	13.27
ELECTRIC PWR LINEMAN	All	ALL		61.09	69.34	1.5	1.5	2.0	2.0	7.25	17.10	0.00	1.83	1.83	10.38	20.76
ELECTRIC PWR TRK DRV	All	ALL		40.46	69.34	1.5	1.5	2.0	2.0	7.25	11.33	0.00	1.21	1.21	6.87	13.75
ELECTRICIAN	All	BLD		47.16	51.41	1.5	1.5	2.0	2.0	14.65	28.19	7.36	1.20		18.39	36.76
ELEVATOR CONSTRUCTOR	All	BLD		67.84	76.32	2.0	2.0	2.0	2.0	16.18	20.96	5.42	0.75		0.00	0.00
FENCE ERECTOR	NE	ALL		51.00	53.00	1.5	1.5	2.0	2.0	13.74	18.32	0.00	0.75		0.00	0.00
GLAZIER	All	BLD		51.55	53.05	1.5	2.0	2.0	2.0	15.64	26.18	0.00	2.27	0.00	0.00	0.00
HEAT/FROST INSULATOR	All	BLD		55.02	58.32	1.5	1.5	2.0	2.0	15.84	19.01	0.00	0.90		4.60	9.20
IRON WORKER	All	ALL		59.26	62.76	2.0	2.0	2.0	2.0	18.30	26.31	0.00	0.49	0.00	0.00	0.00
LABORER	All	ALL		50.15	50.90	1.5	1.5	2.0	2.0	17.71	16.92	0.00	0.91		0.00	0.00
LATHER	All	ALL		55.11	57.11	1.5	1.5	2.0	2.0	12.89	26.26	2.15	0.93	0.00	0.00	0.00
MACHINIST	All	BLD		58.39	62.39	1.5	1.5	2.0	2.0	9.93	8.95	1.85	1.47		0.00	0.00
MARBLE FINISHER	All	ALL		39.50	53.55	1.5	1.5	2.0	2.0	12.70	22.32	0.00	0.73	0.00	2.88	5.76
MARBLE SETTER	All	BLD		51.00	56.10	1.5	1.5	2.0	2.0	12.70	24.01	0.00	0.92	0.00	3.73	7.45
MATERIAL TESTER I	All	ALL		40.15		1.5	1.5	2.0	2.0	17.71	16.92	0.00	0.91		0.00	0.00
MATERIALS TESTER II	All	ALL		45.15		1.5	1.5	2.0	2.0	17.71	16.92	0.00	0.91		0.00	0.00

DuPage County Prevailing Wage Rates posted on 12/16/2024

MILLWRIGHT	All	ALL		55.11	57.11	1.5	1.5	2.0	2.0	12.89	26.26	2.15	0.93	0.00	0.00	0.00
OPERATING ENGINEER	All	BLD	1	60.80	64.80	2.0	2.0	2.0	2.0	23.70	20.80	2.00	2.70	0.00	0.00	0.00
OPERATING ENGINEER	All	BLD	2	59.50	64.80	2.0	2.0	2.0	2.0	23.70	20.80	2.00	2.70	0.00	0.00	0.00
OPERATING ENGINEER	All	BLD	3	56.95	64.80	2.0	2.0	2.0	2.0	23.70	20.80	2.00	2.70	0.00	0.00	0.00
OPERATING ENGINEER	All	BLD	4	55.20	64.80	2.0	2.0	2.0	2.0	23.70	20.80	2.00	2.70	0.00	0.00	0.00
OPERATING ENGINEER	All	BLD	5	64.55	64.80	2.0	2.0	2.0	2.0	23.70	20.80	2.00	2.70	0.00	0.00	0.00
OPERATING ENGINEER	All	BLD	6	61.80	64.80	2.0	2.0	2.0	2.0	23.70	20.80	2.00	2.70	0.00	0.00	0.00
OPERATING ENGINEER	All	BLD	7	63.80	64.80	2.0	2.0	2.0	2.0	23.70	20.80	2.00	2.70	0.00	0.00	0.00
OPERATING ENGINEER	All	FLT		50.50	50.50	1.5	1.5	2.0	2.0	23.95	21.40	2.00	2.85	0.00	0.00	0.00
OPERATING ENGINEER	All	HWY	1	59.00	63.00	1.5	1.5	2.0	2.0	23.70	20.80	2.00	2.70	0.00	0.00	0.00
OPERATING ENGINEER	All	HWY	2	58.45	63.00	1.5	1.5	2.0	2.0	23.70	20.80	2.00	2.70	0.00	0.00	0.00
OPERATING ENGINEER	All	HWY	3	56.40	63.00	1.5	1.5	2.0	2.0	23.70	20.80	2.00	2.70	0.00	0.00	0.00
OPERATING ENGINEER	All	HWY	4	55.00	63.00	1.5	1.5	2.0	2.0	23.70	20.80	2.00	2.70	0.00	0.00	0.00
OPERATING ENGINEER	All	HWY	5	53.80	63.00	1.5	1.5	2.0	2.0	23.70	20.80	2.00	2.70	0.00	0.00	0.00
OPERATING ENGINEER	All	HWY	6	62.00	63.00	1.5	1.5	2.0	2.0	23.70	20.80	2.00	2.70	0.00	0.00	0.00
OPERATING ENGINEER	All	HWY	7	60.00	63.00	1.5	1.5	2.0	2.0	23.70	20.80	2.00	2.70	0.00	0.00	0.00
ORNAMENTAL IRON WORKER	All	ALL		57.51	60.51	2.0	2.0	2.0	2.0	14.31	26.50	0.00	2.00	0.00	0.00	0.00
PAINTER	All	ALL		53.05	55.05	1.5	1.5	1.5	2.0	16.08	9.90	0.00	1.65	0.00	0.00	0.00
PAINTER - SIGNS	All	BLD		45.49	51.09	1.5	1.5	2.0	2.0	8.20	16.81	0.00	0.00	0.00	0.00	0.00
PILEDRIVER	All	ALL		55.11	57.11	1.5	1.5	2.0	2.0	12.89	26.26	2.15	0.93	0.00	0.00	0.00
PIPEFITTER	All	BLD		57.00	60.00	1.5	1.5	2.0	2.0	13.65	22.85	0.00	3.12	0.00	0.00	0.00
PLASTERER	All	BLD		52.00	55.12	1.5	1.5	2.0	2.0	12.70	24.23	0.00	1.18	0.00	4.22	8.43
PLUMBER	All	BLD		58.55	62.05	1.5	1.5	2.0	2.0	17.75	17.74	0.00	1.83		0.00	0.00
ROOFER	All	BLD		50.25	55.25	1.5	1.5	2.0	2.0	11.98	17.34	0.00	1.11	0.00	0.00	0.00
SHEETMETAL WORKER	All	BLD		56.35	60.86	1.5	1.5	2.0	2.0	15.41	19.83	0.00	1.79	2.62	0.00	0.00
SPRINKLER FITTER	All	BLD		60.10	62.85	1.5	1.5	2.0	2.0	14.95	19.30	0.00	1.10	0.00	0.00	0.00
STEEL ERECTOR	All	ALL		59.26	62.76	2.0	2.0	2.0	2.0	18.30	26.31	0.00	0.49	0.00	0.00	0.00
STONE MASON	All	BLD		52.06	57.27	1.5	1.5	2.0	2.0	12.70	24.54	0.00	1.24	0.00	3.99	7.98
SURVEY WORKER	All	BLD		56.50	57.50	1.5	1.5	2.0	2.0	17.75	14.15	0.00	1.49		0.00	0.00

DuPage County Prevailing Wage Rates posted on 12/16/2024

SURVEY WORKER	All	HWY		56.50	57.50	1.5	1.5	2.0	2.0	17.75	14.15	0.00	1.49		0.00	0.00
TERRAZZO FINISHER	All	BLD		48.94	48.94	1.5	1.5	2.0	2.0	13.00	18.42	0.00	1.11	0.00	4.22	8.44
TERRAZZO MECHANIC	All	BLD		52.85	56.35	1.5	1.5	2.0	2.0	13.00	19.81	0.00	1.15	0.00	4.47	8.94
TRAFFIC SAFETY WORKER I	All	HWY		42.10	43.70	1.5	1.5	2.0	2.0	11.11	9.81	0.00	1.05	0.00	0.00	0.00
TRAFFIC SAFETY WORKER II	ALL	HWY		43.10	44.70	1.5	1.5	2.0	2.0	11.11	9.81	0.00	1.05	0.00	0.00	0.00
TRUCK DRIVER	All	ALL	1	44.06		1.5	1.5	2.0	2.0	11.65	15.35	0.00	0.25	0.00	0.00	0.00
TRUCK DRIVER	All	ALL	2	44.21		1.5	1.5	2.0	2.0	11.65	15.35	0.00	0.25	0.00	0.00	0.00
TRUCK DRIVER	All	ALL	3	44.41		1.5	1.5	2.0	2.0	11.65	15.35	0.00	0.25	0.00	0.00	0.00
TRUCK DRIVER	All	ALL	4	44.61		1.5	1.5	2.0	2.0	11.65	15.35	0.00	0.25	0.00	0.00	0.00
TUCK POINTER	All	BLD		51.53	52.53	1.5	1.5	2.0	2.0	10.05	22.66	0.00	1.15	0.00	0.00	0.00

Legend

Rg Region

Type Trade Type - All,Highway,Building,Floating,Oil & Chip,Rivers

C Class

Base Base Wage Rate

OT M-F Unless otherwise noted, OT pay is required for any hour greater than 8 worked each day, Mon through Fri. The number listed is the multiple of the base wage.

OT Sa Overtime pay required for every hour worked on Saturdays

OT Su Overtime pay required for every hour worked on Sundays

OT Hol Overtime pay required for every hour worked on Holidays

H/W Health/Welfare benefit

Vac Vacation

Trng Training

Other Ins Employer hourly cost for any other type(s) of insurance provided for benefit of worker.

Explanations DUPAGE COUNTY

IRON WORKERS AND FENCE ERECTOR (WEST) - West of Route 53.

The following list is considered as those days for which holiday rates of wages for work performed apply: New Years Day, Memorial Day, Fourth of July, Labor Day, Thanksgiving Day, Christmas Day and Veterans Day in some classifications/counties. Generally, any of these holidays which fall on a Sunday is celebrated on the following Monday. This then makes work performed on that Monday payable at the appropriate overtime rate for holiday pay. Common practice in a given local may alter certain days of celebration. If in doubt, please check with IDOL.

EXPLANATION OF CLASSES

DuPage County Prevailing Wage Rates posted on 12/16/2024

ASBESTOS - GENERAL - removal of asbestos material/mold and hazardous materials from any place in a building, including mechanical systems where those mechanical systems are to be removed. This includes the removal of asbestos materials/mold and hazardous materials from ductwork or pipes in a building when the building is to be demolished at the time or at some close future date.

ASBESTOS - MECHANICAL - removal of asbestos material from mechanical systems, such as pipes, ducts, and boilers, where the mechanical systems are to remain.

TRAFFIC SAFETY Worker I

Traffic Safety Worker I - work associated with the delivery, installation, pick-up and servicing of safety devices during periods of roadway construction, including such work as set-up and maintenance of barricades, barrier wall reflectors, drums, cones, delineators, signs, crash attenuators, glare screen and other such items, and the layout and application or removal of conflicting and/or temporary roadway markings utilized to control traffic in construction zones, as well as flagging for these operations.

TRAFFIC SAFETY WORKER II

Work associated with the installation and removal of permanent pavement markings and/or pavement markers including both installations performed by hand and installations performed by truck.

CERAMIC TILE FINISHER

The grouting, cleaning, and polishing of all classes of tile, whether for interior or exterior purposes, all burned, glazed or unglazed products; all composition materials, granite tiles, warning detectable tiles, cement tiles, epoxy composite materials, pavers, glass, mosaics, fiberglass, and all substitute materials, for tile made in tile-like units; all mixtures in tile like form of cement, metals, and other materials that are for and intended for use as a finished floor surface, stair treads, promenade roofs, walks, walls, ceilings, swimming pools, and all other places where tile is to form a finished interior or exterior. The mixing of all setting mortars including but not limited to thin-set mortars, epoxies, wall mud, and any other sand and cement mixtures or adhesives when used in the preparation, installation, repair, or maintenance of tile and/or similar materials. The handling and unloading of all sand, cement, lime, tile, fixtures, equipment, adhesives, or any other materials to be used in the preparation, installation, repair, or maintenance of tile and/or similar materials. Ceramic Tile Finishers shall fill all joints and voids regardless of method on all tile work, particularly and especially after installation of said tile work. Application of any and all protective coverings to all types of tile installations including, but not be limited to, all soap compounds, paper products, tapes, and all polyethylene coverings, plywood, masonite, cardboard, and any new type of products that may be used to protect tile installations, Blastrac equipment, and all floor scarifying equipment used in preparing floors to receive tile. The clean up and removal of all waste and materials. All demolition of existing tile floors and walls to be re-tiled.

COMMUNICATIONS TECHNICIAN

Low voltage installation, maintenance and removal of telecommunication facilities (voice, sound, data and video) including telephone and data inside wire, interconnect, terminal equipment, central offices, PABX, fiber optic cable and equipment, micro waves, V-SAT, bypass, CATV, WAN (wide area networks), LAN (local area networks), and ISDN (integrated system digital network),

DuPage County Prevailing Wage Rates posted on 12/16/2024

pulling of wire in raceways, but not the installation of raceways.

MARBLE FINISHER

Loading and unloading trucks, distribution of all materials (all stone, sand, etc.), stocking of floors with material, performing all rigging for heavy work, the handling of all material that may be needed for the installation of such materials, building of scaffolding, polishing if needed, patching, waxing of material if damaged, pointing up, caulking, grouting and cleaning of marble, holding water on diamond or Carborundum blade or saw for setters cutting, use of tub saw or any other saw needed for preparation of material, drilling of holes for wires that anchor material set by setters, mixing up of molding plaster for installation of material, mixing up thin set for the installation of material, mixing up of sand to cement for the installation of material and such other work as may be required in helping a Marble Setter in the handling of all material in the erection or installation of interior marble, slate, travertine, art marble, serpentine, alberene stone, blue stone, granite and other stones (meaning as to stone any foreign or domestic materials as are specified and used in building interiors and exteriors and customarily known as stone in the trade), carrara, sanionyx, vitrolite and similar opaque glass and the laying of all marble tile, terrazzo tile, slate tile and precast tile, steps, risers treads, base, or any other materials that may be used as substitutes for any of the aforementioned materials and which are used on interior and exterior which are installed in a similar manner.

MATERIAL TESTER I: Hand coring and drilling for testing of materials; field inspection of uncured concrete and asphalt.

MATERIAL TESTER II: Field inspection of welds, structural steel, fireproofing, masonry, soil, facade, reinforcing steel, formwork, cured concrete, and concrete and asphalt batch plants; adjusting proportions of bituminous mixtures.

OPERATING ENGINEER - BUILDING

Class 1. Asphalt Plant; Asphalt Spreader; Autograde; Backhoes with Caisson Attachment; Batch Plant; Benoto (requires Two Engineers); Boiler and Throttle Valve; Caisson Rigs; Central Redi-Mix Plant; Combination Back Hoe Front End-loader Machine; Compressor and Throttle Valve; Concrete Breaker (Truck Mounted); Concrete Conveyor; Concrete Conveyor (Truck Mounted); Concrete Paver Over 27E cu. ft; Concrete Paver 27E cu. ft. and Under; Concrete Placer; Concrete Placing Boom; Concrete Pump (Truck Mounted); Concrete Tower; Cranes, All; Cranes, Hammerhead; Cranes, (GCI and similar Type); Creter Crane; Spider Crane; Crusher, Stone, etc.; Derricks, All; Derricks, Traveling; Formless Curb and Gutter Machine; Grader, Elevating; Grouting Machines; Heavy Duty Self-Propelled Transporter or Prime Mover; Highlift Shovels or Front Endloader 2-1/4 yd. and over; Hoists, Elevators, outside type rack and pinion and similar machines; Hoists, One, Two and Three Drum; Hoists, Two Tugger One Floor; Hydraulic Backhoes; Hydraulic Boom Trucks; Hydro Vac (and similar equipment); Locomotives, All; Motor Patrol; Lubrication Technician; Manipulators; Pile Drivers and Skid Rig; Post Hole Digger; Pre-Stress Machine; Pump Cretes Dual Ram; Pump Cretes: Squeeze Cretes-Screw Type Pumps; Gypsum Bulker and Pump; Raised and Blind Hole Drill; Roto Mill Grinder; Scoops - Tractor Drawn; Slip-Form Paver; Straddle Buggies; Operation of Tie Back Machine; Tournapull; Tractor with Boom and Side Boom; Trenching Machines.

Class 2. Boilers; Broom, All Power Propelled; Bulldozers; Concrete Mixer (Two Bag and Over); Conveyor, Portable; Forklift Trucks; Highlift Shovels or Front Endloaders under 2-1/4 yd.; Hoists, Automatic; Hoists, Inside Elevators; Hoists, Sewer Dragging Machine; Hoists, Tugger Single Drum; Laser Screed; Rock Drill (Self-Propelled); Rock Drill (Truck Mounted); Rollers, All; Steam Generators; Tractors, All; Tractor Drawn Vibratory Roller; Winch Trucks with "A" Frame.

DuPage County Prevailing Wage Rates posted on 12/16/2024

Class 3. Air Compressor; Combination Small Equipment Operator; Generators; Heaters, Mechanical; Hoists, Inside Elevators (remodeling or renovation work); Hydraulic Power Units (Pile Driving, Extracting, and Drilling); Pumps, over 3" (1 to 3 not to exceed a total of 300 ft.); Low Boys; Pumps, Well Points; Welding Machines (2 through 5); Winches, 4 Small Electric Drill Winches.

Class 4. Bobcats and/or other Skid Steer Loaders; Oilers; and Brick Forklift.

Class 5. Assistant Craft Foreman.

Class 6. Gradall.

Class 7. Mechanics; Welders.

OPERATING ENGINEERS - HIGHWAY CONSTRUCTION

Class 1. Asphalt Plant; Asphalt Heater and Planer Combination; Asphalt Heater Scarfire; Asphalt Spreader; Autograder/GOMACO or other similar type machines; ABG Paver; Backhoes with Caisson Attachment; Ballast Regulator; Belt Loader; Caisson Rigs; Car Dumper; Central Redi-Mix Plant; Combination Backhoe Front Endloader Machine, (1 cu. yd. Backhoe Bucket or over or with attachments); Concrete Breaker (Truck Mounted); Concrete Conveyor; Concrete Paver over 27E cu. ft.; Concrete Placer; Concrete Tube Float; Cranes, all attachments; Cranes, Tower Cranes of all types: Creter Crane; Spider Crane; Crusher, Stone, etc.; Derricks, All; Derrick Boats; Derricks, Traveling; Dredges; Elevators, Outside type Rack & Pinion and Similar Machines; Formless Curb and Gutter Machine; Grader, Elevating; Grader, Motor Grader, Motor Patrol, Auto Patrol, Form Grader, Pull Grader, Subgrader; Guard Rail Post Driver Truck Mounted; Hoists, One, Two and Three Drum; Heavy Duty Self-Propelled Transporter or Prime Mover; Hydraulic Backhoes; Backhoes with shear attachments up to 40' of boom reach; Lubrication Technician; Manipulators; Mucking Machine; Pile Drivers and Skid Rig; Pre-Stress Machine; Pump Cretes Dual Ram; Rock Drill - Crawler or Skid Rig; Rock Drill - Truck Mounted; Rock/Track Tamper; Roto Mill Grinder; Slip-Form Paver; Snow Melters; Soil Test Drill Rig (Truck Mounted); Straddle Buggies; Hydraulic Telescoping Form (Tunnel); Operation of Tieback Machine; Tractor Drawn Belt Loader; Tractor Drawn Belt Loader (with attached pusher - two engineers); Tractor with Boom; Tractaire with Attachments; Traffic Barrier Transfer Machine; Trenching; Truck Mounted Concrete Pump with Boom; Raised or Blind Hole Drills (Tunnel Shaft); Underground Boring and/or Mining Machines 5 ft. in diameter and over tunnel, etc; Underground Boring and/or Mining Machines under 5 ft. in diameter; Wheel Excavator; Widener (APSCO).

Class 2. Batch Plant; Bituminous Mixer; Boiler and Throttle Valve; Bulldozers; Car Loader Trailing Conveyors; Combination Backhoe Front Endloader Machine (Less than 1 cu. yd. Backhoe Bucket or over or with attachments); Compressor and Throttle Valve; Compressor, Common Receiver (3); Concrete Breaker or Hydro Hammer; Concrete Grinding Machine; Concrete Mixer or Paver 7S Series to and including 27 cu. ft.; Concrete Spreader; Concrete Curing Machine, Burlap Machine, Belting Machine and Sealing Machine; Concrete Wheel Saw; Conveyor Muck Cars (Haglund or Similar Type); Drills, All; Finishing Machine - Concrete; Highlift Shovels or Front Endloader; Hoist - Sewer Dragging Machine; Hydraulic Boom Trucks (All Attachments); Hydro-Blaster; Hydro Excavating (excluding hose work); Laser Screed; All Locomotives, Dinky; Off-Road Hauling Units (including articulating) Non Self-Loading Ejection Dump; Pump Cretes: Squeeze Cretes - Screw Type Pumps, Gypsum Bulker and Pump; Roller, Asphalt; Rotary Snow Plows; Rototiller, Seaman, etc., self-propelled; Self-Propelled Compactor; Spreader - Chip - Stone, etc.; Scraper - Single/Twin Engine/Push and Pull; Scraper - Prime Mover in Tandem (Regardless of Size); Tractors pulling attachments, Sheeps Foot, Disc, Compactor, etc.; Tug Boats.

DuPage County Prevailing Wage Rates posted on 12/16/2024

Class 3. Boilers; Brooms, All Power Propelled; Cement Supply Tender; Compressor, Common Receiver (2); Concrete Mixer (Two Bag and Over); Conveyor, Portable; Farm-Type Tractors Used for Mowing, Seeding, etc.; Forklift Trucks; Grouting Machine; Hoists, Automatic; Hoists, All Elevators; Hoists, Tugger Single Drum; Jeep Diggers; Low Boys; Pipe Jacking Machines; Post-Hole Digger; Power Saw, Concrete Power Driven; Pug Mills; Rollers, other than Asphalt; Seed and Straw Blower; Steam Generators; Stump Machine; Winch Trucks with "A" Frame; Work Boats; Tamper-Form-Motor Driven.

Class 4. Air Compressor; Combination - Small Equipment Operator; Directional Boring Machine; Generators; Heaters, Mechanical; Hydraulic Power Unit (Pile Driving, Extracting, or Drilling); Light Plants, All (1 through 5); Pumps, over 3" (1 to 3 not to exceed a total of 300 ft.); Pumps, Well Points; Vacuum Trucks (excluding hose work); Welding Machines (2 through 5); Winches, 4 Small Electric Drill Winches.

Class 5. SkidSteer Loader (all); Brick Forklifts; Oilers.

Class 6. Field Mechanics and Field Welders

Class 7. Dowell Machine with Air Compressor; Gradall and machines of like nature.

OPERATING ENGINEER - FLOATING

Diver. Diver Wet Tender, Diver Tender, ROV Pilot, ROV Tender

TRUCK DRIVER - BUILDING, HEAVY AND HIGHWAY CONSTRUCTION

Class 1. Two or three Axle Trucks. A-frame Truck when used for transportation purposes; Air Compressors and Welding Machines, including those pulled by cars, pick-up trucks and tractors; Ambulances; Batch Gate Lockers; Batch Hopperman; Car and Truck Washers; Carry-alls; Fork Lifts and Hoisters; Helpers; Mechanics Helpers and Greasers; Oil Distributors 2-man operation; Pavement Breakers; Pole Trailer, up to 40 feet; Power Mower Tractors; Self-propelled Chip Spreader; Skipman; Slurry Trucks, 2-man operation; Slurry Truck Conveyor Operation, 2 or 3 man; Teamsters; Unskilled Dumpman; and Truck Drivers hauling warning lights, barricades, and portable toilets on the job site.

Class 2. Four axle trucks; Dump Crets and Adgetors under 7 yards; Dumpsters, Track Trucks, Euclids, Hug Bottom Dump Turnapulls or Turnatrailers when pulling other than self-loading equipment or similar equipment under 16 cubic yards; Mixer Trucks under 7 yards; Ready-mix Plant Hopper Operator, and Winch Trucks, 2 Axles.

Class 3. Five axle trucks; Dump Crets and Adgetors 7 yards and over; Dumpsters, Track Trucks, Euclids, Hug Bottom Dump Turnatrailers or turnapulls when pulling other than self-loading equipment or similar equipment over 16 cubic yards; Explosives and/or Fission Material Trucks; Mixer Trucks 7 yards or over; Mobile Cranes while in transit; Oil Distributors, 1-man operation; Pole Trailer, over 40 feet; Pole and Expandable Trailers hauling material over 50 feet long; Slurry trucks, 1-man operation; Winch trucks, 3 axles or more; Mechanic--Truck Welder and Truck Painter.

Class 4. Six axle trucks; Dual-purpose vehicles, such as mounted crane trucks with hoist and accessories; Foreman; Master Mechanic; Self-loading equipment like P.B. and trucks with scoops on the front.

DuPage County Prevailing Wage Rates posted on 12/16/2024

SURVEY WORKER

Operates survey equipment (such as levels, transits, data collectors, GPS and robotic total stations) for the purpose of performing construction layout and/or grade checking.

SURVEY FOREMAN

Operates survey equipment (such as levels, transits, data collectors, GPS and robotic total stations) for the purpose of performing construction layout and/or grade checking; oversees survey crew operations; and/or coordinates work of survey crews.

TERRAZZO FINISHER

The handling of sand, cement, marble chips, and all other materials that may be used by the Mosaic Terrazzo Mechanic, and the mixing, grinding, grouting, cleaning and sealing of all Marble, Mosaic, and Terrazzo work, floors, base, stairs, and wainscoting by hand or machine, and in addition, assisting and aiding Marble, Masonic, and Terrazzo Mechanics.

Other Classifications of Work:

For definitions of classifications not otherwise set out, the Department generally has on file such definitions which are available. If a task to be performed is not subject to one of the classifications of pay set out, the Department will upon being contacted state which neighboring county has such a classification and provide such rate, such rate being deemed to exist by reference in this document. If no neighboring county rate applies to the task, the Department shall undertake a special determination, such special determination being then deemed to have existed under this determination. If a project requires these, or any classification not listed, please contact IDOL at 217-782-1710 for wage rates or clarifications.

LANDSCAPING

Landscaping work falls under the existing classifications for laborer, operating engineer and truck driver. The work performed by landscape plantsman and landscape laborer is covered by the existing classification of laborer. The work performed by landscape operators (regardless of equipment used or its size) is covered by the classifications of operating engineer. The work performed by landscape truck drivers (regardless of size of truck driven) is covered by the classifications of truck driver.

MATERIAL TESTER & MATERIAL TESTER/INSPECTOR I AND II

Notwithstanding the difference in the classification title, the classification entitled "Material Tester I" involves the same job duties as the classification entitled "Material Tester/Inspector I". Likewise, the classification entitled "Material Tester II" involves the same job duties as the classification entitled "Material Tester/Inspector II".

NOT FOR BID

**DCEO DRAINAGE IMPROVEMENT PROJECT (VARIOUS LOCATIONS)
VILLAGE OF VILLA PARK**

APPENDIX E

DCEO GRANT AGREEMENT

NOT FOR BID



Illinois Department of Commerce & Economic Opportunity

JB Pritzker, Governor

December 20, 2023

Nick Cuzzone
Village President
Village of Villa Park
20 South Ardmore Avenue
Villa Park, IL 60181-2610

Dear Hon. Cuzzone,

The Department of Commerce and Economic Opportunity (the Department) would like to welcome you to our community of grantees and congratulate you on your grant award (21-413011).

The Department administers a wide range of economic and workforce development programs, services and initiatives designed to create and retain high quality jobs and build strong communities. The Department leads the Illinois economic development process in partnership with businesses, local governments, workers and families.

When administering grant programs, the Department follows guidance from the Grant Accountability and Transparency Act (GATA) (44 Ill. Admin. Code Part 7000) and federal uniform guidance (2CFR 200 Uniform Administrative Requirements, Cost Principles, and Audit Requirements for Federal Awards).

To ensure your organization achieves its goals and objectives and remains in compliance with the grant terms, we have provided a few helpful resources and tips to get you started:

1. Read and understand your grant agreement. The grant agreement outlines grant requirements and programmatic deliverables.
2. Frequent our Grantee Resource Site to review tutorials on the grant process (go to www.illinois.gov/dceo, click on Grant Opportunities and Grantee Resource Site).
3. Maintain your organization's profile on the Illinois GATA Grantee Portal at grants.illinois.gov/portal (i.e. confirm organization and contact information, monitor pre-qualification status, make indirect cost elections and comply with audit requirements).
4. Keep all relevant grant-related documents during the required record retention period. This includes receipts and proof of payment for all grant expenditures, such as, invoices, proposals, contracts, procurement bids, statements of work, bank statements, copies of check and ACH/Wire Transfer documentation. (Please refer to your grant agreement for the record retention period).
5. If your organization expends over \$300,000 in state or federal grant funds during its fiscal year, a financial statement or single audit may be required. Please note, this expense may not be covered with grant funds.

If you have any questions or concerns, please contact your grant manager.

Sincerely,

Kristin A. Richards
Director



**GRANT AGREEMENT
BETWEEN
THE STATE OF ILLINOIS, DEPARTMENT OF COMMERCE AND ECONOMIC OPPORTUNITY
AND
Village of Villa Park**

The parties to this Grant Agreement (Agreement) are the State of Illinois (State), acting through the undersigned agency (Grantor) and Village of Villa Park (Grantee) (collectively, the "Parties" and individually, a "Party"). The Agreement, consisting of the signature page, the parts listed below, and any additional exhibits or attachments referenced in this Agreement, constitute the entire agreement between the Parties. No promises, terms, or conditions not recited, incorporated or referenced herein, including prior agreements or oral discussions, are binding upon either Grantee or Grantor.

PART ONE – The Uniform Terms

Article I	Definitions
Article II	Award Information
Article III	Grantee Certifications and Representations
Article IV	Payment Requirements
Article V	Scope of Award Activities/Purpose of Award
Article VI	Budget
Article VII	Allowable Costs
Article VIII	Lobbying
Article IX	Maintenance and Accessibility of Records; Monitoring
Article X	Financial Reporting Requirements
Article XI	Performance Reporting Requirements
Article XII	Audit Requirements
Article XIII	Termination; Suspension; Non-compliance
Article XIV	Subcontracts/Subawards
Article XV	Notice of Change
Article XVI	Structural Reorganization and Reconstitution of Board Membership
Article XVII	Conflict of Interest
Article XVIII	Equipment or Property
Article XIX	Promotional Materials; Prior Notification
Article XX	Insurance
Article XXI	Lawsuits and Indemnification
Article XXII	Miscellaneous
Exhibit A	Project Description
Exhibit B	Deliverables or Milestones
Exhibit C	Contact Information
Exhibit D	Performance Measures and Standards
Exhibit E	Specific Conditions

PART TWO – Grantor-Specific Terms

PART THREE – Project-Specific Terms

The Parties or their duly authorized representatives hereby execute this Agreement.

ILLINOIS DEPARTMENT OF COMMERCE AND ECONOMIC OPPORTUNITY

VILLAGE OF VILLA PARK

By: [Signature]
By: Meghan L. Street
Cash Desk Manager
Signature of Kristin A. Richards, Director

By: [Signature]
Signature of Authorized Representative

Date: 12/29/23

Date: 12/12/2023

By: _____
Signature of Designee

Printed Name: Matt Harline Nick CUZZONE

Date: _____

Printed Title: Village Manager Village President

Printed Name: _____

Email: robharline@invillapark.com
President CUZZONE@invillapark.com

Printed Title: _____

Designee

By: _____
Signature of Second Grantor Approver, if applicable

By: _____
Signature of Second Grantee Approver, if applicable

Date: _____

Date: _____

Printed Name: _____

Printed Name: _____

Printed Title: _____

Second Grantor Approver

Printed Title: _____

Second Grantee Approver
(optional at Grantee's discretion)

By: _____
Signature of Third Grantor Approver, if applicable

Date: _____

Printed Name: _____

Printed Title: _____

Third Grantor Approver

PART ONE – THE UNIFORM TERMS

**ARTICLE I
DEFINITIONS**

1.1. Definitions. Capitalized words and phrases used in this Agreement have the meanings stated in 2 CFR 200.1 unless otherwise stated below.

"Allowable Costs" has the same meaning as in 44 Ill. Admin. Code 7000.30.

"Award" has the same meaning as in 44 Ill. Admin. Code 7000.30.

"Budget" has the same meaning as in 44 Ill. Admin. Code 7000.30.

"Catalog of State Financial Assistance" or "CSFA" has the same meaning as in 44 Ill. Admin. Code 7000.30.

"Close-out Report" means a report from the Grantee allowing Grantor to determine whether all applicable administrative actions and required work have been completed, and therefore closeout actions can commence.

"Conflict of Interest" has the same meaning as in 44 Ill. Admin. Code 7000.30.

"Cooperative Research and Development Agreement" has the same meaning as in 15 USC 3710a.

"Direct Costs" has the same meaning as in 44 Ill. Admin. Code 7000.30.

"Financial Assistance" has the same meaning as in 44 Ill. Admin. Code 7000.30.

"GATU" has the same meaning as in 44 Ill. Admin. Code 7000.30.

"Grant Agreement" has the same meaning as in 44 Ill. Admin. Code 7000.30.

"Grant Funds" means the Financial Assistance made available to Grantee through this Agreement.

"Grantee Portal" has the same meaning as in 44 Ill. Admin. Code 7000.30.

"Indirect Costs" has the same meaning as in 44 Ill. Admin. Code 7000.30.

"Indirect Cost Rate" means a device for determining in a reasonable manner the proportion of Indirect Costs each Program should bear. It is a ratio (expressed as a percentage) of the Indirect Costs to a Direct Cost base. If reimbursement of Indirect Costs is allowable under an Award, Grantor will not reimburse those Indirect Costs unless Grantee has established an Indirect Cost Rate covering the applicable activities and period of time, unless Indirect Costs are reimbursed at a fixed rate.

"Indirect Cost Rate Proposal" has the same meaning as in 44 Ill. Admin. Code 7000.30.

"Obligations" has the same meaning as in 44 Ill. Admin. Code 7000.30.

"Period of Performance" has the same meaning as in 44 Ill. Admin. Code 7000.30.

"Prior Approval" has the same meaning as in 44 Ill. Admin. Code 7000.30.

"Profit" means an entity's total revenue less its operating expenses, interest paid, depreciation, and taxes. "Profit" is synonymous with the term "net revenue."

"Program" means the services to be provided pursuant to this Agreement. "Program" is used interchangeably with "Project."

"Program Costs" means all Allowable Costs incurred by Grantee and the value of the contributions made by third parties in accomplishing the objectives of the Award during the Term of this Agreement.

"Related Parties" has the meaning set forth in Financial Accounting Standards Board (FASB) Accounting Standards Codification (ASC) 850-10-20.

"SAM" means the federal System for Award Management (SAM), the federal repository into which an entity must provide information required for the conduct of business as a recipient.

"State Grantee Compliance Enforcement System" means the statewide framework for State agencies to manage occurrences of non-compliance with Award requirements.

"State-issued Award" means the assistance that a grantee receives directly from a State agency. The funding source of the State-issued Award can be federal pass-through, State or a combination thereof. "State-issued Award" does not include the following:

- contracts issued pursuant to the Illinois Procurement Code that a State agency uses to buy goods or services from a contractor or a contract to operate State government-owned, contractor-operated facilities;
- agreements that meet the definition of "contract" under 2 CFR 200.1 and 2 CFR 200.331, which a State agency uses to procure goods or services but are exempt from the Illinois Procurement Code due to an exemption listed under 30 ILCS 500/1-10, or pursuant to a disaster proclamation, executive order, or any other exemption permitted by law;
- amounts received for services rendered to an individual;
- Cooperative Research and Development Agreements;
- an agreement that provides only direct cash assistance to an individual;
- a subsidy;
- a loan;
- a loan guarantee; or
- insurance.

"Illinois Stop Payment List" has the same meaning as in 44 Ill. Admin. Code 7000.30.

"Unallowable Cost" has the same meaning as in 44 Ill. Admin. Code 7000.30.

"Unique Entity Identifier" or "UEI" has the same meaning as in 44 Ill. Admin. Code 7000.30.

ARTICLE II AWARD INFORMATION

2.1. **Term.** This Agreement is effective on **10/01/2023** and expires on **09/30/2025** (the Term), unless terminated pursuant to this Agreement.

2.2. **Amount of Agreement.** Grant Funds must not exceed **\$288,500.00**, of which **\$288,500.00** are federal funds. Grantee accepts Grantor's payment as specified in this ARTICLE.

2.3. Payment. Payment will be made as follows (see additional payment requirements in ARTICLE IV; additional payment provisions specific to this Award may be included in **PART TWO** or **PART THREE**):

The Award amount listed in Paragraph 2.2 is not a guarantee of payment, and Grantee’s receipt of Grant Funds is contingent upon all terms and conditions of this Agreement.

Reimbursement

Payments to the Grantee are subject to the Grantee’s submission and certification of eligible costs and any documentation as required by the Grantor. Payment shall be initiated upon the Grantor’s approval of eligible costs and cash amount requested for reimbursement of those costs.

2.4. Award Identification Numbers. If applicable, the Federal Award Identification Number (FAIN) is **SLT-3381**, the federal awarding agency is **Department Of The Treasury**, and the Federal Award date is **03/03/2021**. If applicable, the Assistance Listing Program Title is **The American Rescue Plan Act/State Fiscal Recovery Fund Program** and Assistance Listing Number is **21.027**. The Catalog of State Financial Assistance (CSFA) Number is 420-27-2662 and the CSFA Name is Installation and/or Replacement of Utilities. If applicable, the State Award Identification Number (SAIN) is 2662-44367.

**ARTICLE III
GRANTEE CERTIFICATIONS AND REPRESENTATIONS**

3.1. Registration Certification. Grantee certifies that: (i) it is registered with SAM and **TGAEKG77EJ1** is Grantee’s correct UEI; (ii) it is in good standing with the Illinois Secretary of State, if applicable; and (iii) Grantee has successfully completed the annual registration and prequalification through the Grantee Portal.

Grantee must remain current with these registrations and requirements. If Grantee’s status with regard to any of these requirements changes, or the certifications made in and information provided in the uniform grant application changes, Grantee must notify Grantor in accordance with ARTICLE XV.

3.2. Tax Identification Certification. Grantee certifies that: **366006132** is Grantee’s correct federal employer identification number (FEIN) or Social Security Number. Grantee further certifies, if applicable: (a) that Grantee is not subject to backup withholding because (i) Grantee is exempt from backup withholding, or (ii) Grantee has not been notified by the Internal Revenue Service (IRS) that Grantee is subject to backup withholding as a result of a failure to report all interest or dividends, or (iii) the IRS has notified Grantee that Grantee is no longer subject to backup withholding; and (b) Grantee is a U.S. citizen or other U.S. person. Grantee is doing business as a (check one):

- | | |
|--|---|
| <input type="checkbox"/> Individual | <input type="checkbox"/> Pharmacy-Non Corporate |
| <input type="checkbox"/> Sole Proprietorship | <input type="checkbox"/> Pharmacy/Funeral Home/Cemetery Corp. |
| <input type="checkbox"/> Partnership | <input type="checkbox"/> Tax Exempt |
| <input type="checkbox"/> Corporation (includes Not For Profit) | <input type="checkbox"/> Limited Liability Company (select applicable tax classification) |
| <input type="checkbox"/> Medical Corporation | <input type="checkbox"/> P = partnership |
| <input checked="" type="checkbox"/> Governmental Unit | <input type="checkbox"/> C = corporation |
| <input type="checkbox"/> Estate or Trust | |

If Grantee has not received a payment from the State of Illinois in the last two years, Grantee must submit a W-9 tax form with this Agreement.

3.3. Compliance with Uniform Grant Rules. Grantee certifies that it must adhere to the applicable Uniform Administrative Requirements, Cost Principles, and Audit Requirements for Federal Awards, which are published in Title 2, Part 200 of the Code of Federal Regulations (2 CFR Part 200) and are incorporated herein by reference. 44 Ill. Admin. Code 7000.40(c)(1)(A). The requirements of 2 CFR Part 200 apply to the Grant Funds

awarded through this Agreement, regardless of whether the original source of the funds is State or federal, unless an exception is noted in federal or State statutes or regulations. 30 ILCS 708/5(b).

3.4. **Representations and Use of Funds.** Grantee certifies under oath that (1) all representations made in this Agreement are true and correct and (2) all Grant Funds awarded pursuant to this Agreement must be used only for the purpose(s) described herein. Grantee acknowledges that the Award is made solely upon this certification and that any false statements, misrepresentations, or material omissions will be the basis for immediate termination of this Agreement and repayment of all Grant Funds.

3.5. **Specific Certifications.** Grantee is responsible for compliance with the enumerated certifications in this Paragraph to the extent that the certifications apply to Grantee.

(a) **Bribery.** Grantee certifies that it has not been convicted of bribery or attempting to bribe an officer or employee of the State of Illinois, nor made an admission of guilt of such conduct which is a matter of record.

(b) **Bid Rigging.** Grantee certifies that it has not been barred from contracting with a unit of State or local government as a result of a violation of Paragraph 33E-3 or 33E-4 of the Criminal Code of 2012 (720 ILCS 5/33E-3 or 720 ILCS 5/33E-4, respectively).

(c) **Debt to State.** Grantee certifies that neither it, nor its affiliate(s), is/are barred from receiving an Award because Grantee, or its affiliate(s), is/are delinquent in the payment of any debt to the State, unless Grantee, or its affiliate(s), has/have entered into a deferred payment plan to pay off the debt.

(d) **International Boycott.** Grantee certifies that neither it nor any substantially owned affiliated company is participating or will participate in an international boycott in violation of the provision of the Anti-Boycott Act of 2018, Part II of the Export Control Reform Act of 2018 (50 USC 4841 through 4843), and the anti-boycott provisions set forth in Part 760 of the federal Export Administration Regulations (15 CFR Parts 730 through 774).

(e) **Discriminatory Club Dues or Fees.** Grantee certifies that it is not prohibited from receiving an Award because it pays dues or fees on behalf of its employees or agents, or subsidizes or otherwise reimburses employees or agents for payment of their dues or fees to any club which unlawfully discriminates (775 ILCS 25/2).

(f) **Pro-Children Act.** Grantee certifies that it is in compliance with the Pro-Children Act of 2001 in that it prohibits smoking in any portion of its facility used for the provision of health, day care, early childhood development services, education or library services to children under the age of eighteen (18) (except such portions of the facilities which are used for inpatient substance abuse treatment) (20 USC 7181-7184).

(g) **Drug-Free Workplace.** If Grantee is not an individual, Grantee certifies it will provide a drug free workplace pursuant to the Drug Free Workplace Act. 30 ILCS 580/3. If Grantee is an individual and this Agreement is valued at more than \$5,000, Grantee certifies it will not engage in the unlawful manufacture, distribution, dispensation, possession, or use of a controlled substance during the performance of the Agreement. 30 ILCS 580/4. Grantee further certifies that if it is a recipient of federal pass-through funds, it is in compliance with the government-wide requirements for a drug-free workplace as set forth in 41 USC 8103.

(h) **Motor Voter Law.** Grantee certifies that it is in full compliance with the terms and provisions of the National Voter Registration Act of 1993 (52 USC 20501 et seq.).

- (i) **Clean Air Act and Clean Water Act.** Grantee certifies that it is in compliance with all applicable standards, orders or regulations issued pursuant to the Clean Air Act (42 USC 7401 et seq.) and the Federal Water Pollution Control Act, as amended (33 USC 1251 et seq.).
- (j) **Debarment.** Grantee certifies that it is not debarred, suspended, proposed for debarment or permanent inclusion on the Illinois Stop Payment List, declared ineligible, or voluntarily excluded from participation in this Agreement by any federal department or agency (2 CFR 200.205(a)), or by the State (30 ILCS 708/25(6)(G)).
- (k) **Non-procurement Debarment and Suspension.** Grantee certifies that it is in compliance with Subpart C of 2 CFR Part 180 as supplemented by 2 CFR Part 376, Subpart C.
- (l) **Health Insurance Portability and Accountability Act.** Grantee certifies that it is in compliance with the Health Insurance Portability and Accountability Act of 1996 (HIPAA) (Public Law No. 104-191, 45 CFR Parts 160, 162 and 164, and the Social Security Act, 42 USC 1320d-2 through 1320d-7), in that it may not use or disclose protected health information other than as permitted or required by law and agrees to use appropriate safeguards to prevent use or disclosure of the protected health information. Grantee must maintain, for a minimum of six (6) years, all protected health information.
- (m) **Criminal Convictions.** Grantee certifies that:
- (i) Neither it nor a managerial agent of Grantee (for non-governmental grantees only, this includes any officer, director or partner of Grantee) has been convicted of a felony under the Sarbanes-Oxley Act of 2002, nor a Class 3 or Class 2 felony under Illinois Securities Law of 1953, or that at least five (5) years have passed since the date of the conviction; and
 - (ii) It must disclose to Grantor all violations of criminal law involving fraud, bribery or gratuity violations potentially affecting this Award. Failure to disclose may result in remedial actions as stated in the Grant Accountability and Transparency Act. 30 ILCS 708/40. Additionally, if Grantee receives over \$10 million in total federal Financial Assistance, during the period of this Award, Grantee must maintain the currency of information reported to SAM regarding civil, criminal or administrative proceedings as required by 2 CFR 200.113 and Appendix XII of 2 CFR Part 200, and 30 ILCS 708/40.
- (n) **Federal Funding Accountability and Transparency Act of 2006 (FFATA).** Grantee certifies that it is in compliance with the terms and requirements of 31 USC 6101 with respect to Federal Awards greater than or equal to \$30,000. A FFATA subaward report must be filed by the end of the month following the month in which the award was made.
- (o) **Illinois Works Review Panel.** For Awards made for public works projects, as defined in the Illinois Works Jobs Program Act, Grantee certifies that it and any contractor(s) or subcontractor(s) that performs work using funds from this Award, must, upon reasonable notice, appear before and respond to requests for information from the Illinois Works Review Panel. 30 ILCS 559/20-25(d).
- (p) **Anti-Discrimination.** Grantee certifies that its employees and subcontractors under subcontract made pursuant to this Agreement, must comply with all applicable provisions of State and federal laws and regulations pertaining to nondiscrimination, sexual harassment and equal employment opportunity including, but not limited to: Illinois Human Rights Act (775 ILCS 5/1-101 et seq.), including, without limitation, 44 Ill. Admin. Code 750- Appendix A, which is incorporated herein; Public Works Employment Discrimination Act (775 ILCS 10/1 et seq.); Civil Rights Act of 1964 (as amended) (42 USC 2000a - 2000h-6); Section 504 of the Rehabilitation Act of 1973 (29 USC 794); Americans with Disabilities Act of 1990 (as amended) (42 USC 12101 et seq.); and the Age Discrimination Act of 1975 (42 USC 6101 et seq.).

(q) Internal Revenue Code and Illinois Income Tax Act. Grantee certifies that it complies with all provisions of the federal Internal Revenue Code (26 USC 1), the Illinois Income Tax Act (35 ILCS 5), and all regulations and rules promulgated thereunder, including withholding provisions and timely deposits of employee taxes and unemployment insurance taxes.

ARTICLE IV PAYMENT REQUIREMENTS

4.1. Availability of Appropriation; Sufficiency of Funds. This Agreement is contingent upon and subject to the availability of sufficient funds. Grantor may terminate or suspend this Agreement, in whole or in part, without penalty or further payment being required, if (i) sufficient funds for this Agreement have not been appropriated or otherwise made available to Grantor by the State or the federal funding source, (ii) the Governor or Grantor reserves funds, or (iii) the Governor or Grantor determines that funds will not or may not be available for payment. Grantor must provide notice, in writing, to Grantee of any such funding failure and its election to terminate or suspend this Agreement as soon as practicable. Any suspension or termination pursuant to this Paragraph will be effective upon the date of the written notice unless otherwise indicated.

4.2. Pre-Award Costs. Pre-award costs are not permitted unless specifically authorized by Grantor in **Exhibit A, PART TWO** or **PART THREE** of this Agreement. If they are authorized, pre-award costs must be charged to the initial Budget Period of the Award, unless otherwise specified by Grantor. 2 CFR 200.458.

4.3. Return of Grant Funds. Grantee must liquidate all Obligations incurred under the Award within forty-five (45) days of the end of the Period of Performance, or in the case of capital improvement Awards, within forty-five (45) days of the end of the time period the Grant Funds are available for expenditure or obligation, unless Grantor permits a longer period in **PART TWO OR PART THREE**.

4.4. Cash Management Improvement Act of 1990. Unless notified otherwise in **PART TWO** or **PART THREE**, Grantee must manage federal funds received under this Agreement in accordance with the Cash Management Improvement Act of 1990 (31 USC 6501 et seq.) and any other applicable federal laws or regulations. 2 CFR 200.305; 44 Ill. Admin. Code 7000.120.

4.5. Payments to Third Parties. Grantor will have no liability to Grantee when Grantor acts in good faith to redirect all or a portion of any Grantee payment to a third party. Grantor will be deemed to have acted in good faith when it is in possession of information that indicates Grantee authorized Grantor to intercept or redirect payments to a third party or when so ordered by a court of competent jurisdiction.

4.6. Modifications to Estimated Amount. If the Agreement amount is established on an estimated basis, then it may be increased by mutual agreement at any time during the Term. Grantor may decrease the estimated amount of this Agreement at any time during the Term if (i) Grantor believes Grantee will not use the funds during the Term, (ii) Grantor believes Grantee has used Grant Funds in a manner that was not authorized by this Agreement, (iii) sufficient funds for this Agreement have not been appropriated or otherwise made available to Grantor by the State or the federal funding source, (iv) the Governor or Grantor reserves funds, or (v) the Governor or Grantor determines that funds will or may not be available for payment. Grantee will be notified, in writing, of any adjustment of the estimated amount of this Agreement. In the event of such reduction, services provided by Grantee under **Exhibit A** may be reduced accordingly. Grantor must pay Grantee for work satisfactorily performed prior to the date of the notice regarding adjustment. 2 CFR 200.308.

4.7. Interest.

(a) All interest earned on Grant Funds held by a Grantee will be treated in accordance with 2 CFR 200.305(b)(9), unless otherwise provided in **PART TWO** or **PART THREE**. Grantee must remit annually any amount due in accordance with 2 CFR 200.305(b)(9) or to Grantor, as applicable.

(b) Grant Funds must be placed in an insured account, whenever possible, that bears interest, unless exempted under 2 CFR 200.305(b)(8).

4.8. **Timely Billing Required.** Grantee must submit any payment request to Grantor within fifteen (15) days of the end of the quarter, unless another billing schedule is specified in ARTICLE II, **PART TWO**, or **PART THREE**. Failure to submit such payment request timely will render the amounts billed Unallowable Costs which Grantor cannot reimburse. In the event that Grantee is unable, for good cause, to submit its payment request timely, Grantee shall timely notify Grantor and may request an extension of time to submit the payment request. Grantor's approval of Grantee's request for an extension shall not be unreasonably withheld.

4.9. **Certification.** Pursuant to 2 CFR 200.415, each invoice and report submitted by Grantee (or subrecipient) must contain the following certification by an official authorized to legally bind Grantee (or subrecipient):

By signing this report [or payment request or both], I certify to the best of my knowledge and belief that the report [or payment request] is true, complete, and accurate; that the expenditures, disbursements and cash receipts are for the purposes and objectives set forth in the terms and conditions of the State or federal pass-through award; and that supporting documentation has been submitted as required by the grant agreement. I acknowledge that approval for any other expenditure described herein is considered conditional subject to further review and verification in accordance with the monitoring and records retention provisions of the grant agreement. I am aware that any false, fictitious, or fraudulent information, or the omission of any material fact, may subject me to criminal, civil or administrative penalties for fraud, false statements, false claims or otherwise (U.S. Code Title 18, Section 1001 and Title 31, Sections 3729-3730 and 3801-3812; 30 ILCS 708/120).

ARTICLE V SCOPE OF AWARD ACTIVITIES/PURPOSE OF AWARD

5.1. **Scope of Award Activities/Purpose of Award.** Grantee must perform as described in this Agreement, including as described in **Exhibit A** (Project Description), **Exhibit B** (Deliverables or Milestones), and **Exhibit D** (Performance Measures and Standards), as applicable. Grantee must further comply with all terms and conditions set forth in the Notice of State Award (44 Ill. Admin. Code 7000.360) which is incorporated herein by reference. All Grantor-specific provisions and programmatic reporting required under this Agreement are described in **PART TWO** (Grantor-Specific Terms). All Project-specific provisions and reporting required under this Agreement are described in **PART THREE** (Project-Specific Terms).

5.2. **Scope Revisions.** Grantee must obtain Prior Approval from Grantor whenever a scope revision is necessary for one or more of the reasons enumerated in 44 Ill. Admin. Code 7000.370(b)(2). All requests for scope revisions that require Grantor approval must be signed by Grantee's authorized representative and submitted to Grantor for approval. Expenditure of funds under a requested revision is prohibited and will not be reimbursed if expended before Grantor gives written approval. 2 CFR 200.308.

5.3. **Specific Conditions.** If applicable, specific conditions required after a risk assessment are included in **Exhibit E**. Grantee must adhere to the specific conditions listed therein. 44 Ill. Admin. Code 7000.340(e).

**ARTICLE VI
BUDGET**

6.1. Budget. The Budget submitted by Grantee at application, or a revised Budget subsequently submitted and approved by Grantor, is considered final and is incorporated herein by reference.

6.2. Budget Revisions. Grantee must obtain Prior Approval, whether mandated or discretionary, from Grantor whenever a Budget revision, is necessary for one or more of the reasons enumerated in 44 Ill. Admin. Code 7000.370(b). All requests for Budget revisions that require Grantor approval must be signed by Grantee's authorized representative and submitted to Grantor for approval. Expenditure of funds under a requested revision is prohibited and will not be reimbursed if expended before Grantor gives written approval.

6.3. Notification. Within thirty (30) calendar days from the date of receipt of the request for Budget revisions, Grantor will review the request and notify Grantee whether the Budget revision has been approved, denied, or the date upon which a decision will be reached. 44 Ill. Admin. Code 7000.370(b)(7).

**ARTICLE VII
ALLOWABLE COSTS**

7.1. Allowability of Costs; Cost Allocation Methods. The allowability of costs and cost allocation methods for work performed under this Agreement will be determined in accordance with 2 CFR Part 200 Subpart E and Appendices III, IV, V, and VII.

7.2. Indirect Cost Rate Submission.

(a) All grantees, except for Local Education Agencies (as defined in 34 CFR 77.1), must make an Indirect Cost Rate election in the Grantee Portal, even grantees that do not charge or expect to charge Indirect Costs. 44 Ill. Admin. Code 7000.420(e).

(i) Waived and de minimis Indirect Cost Rate elections will remain in effect until Grantee elects a different option.

(b) Grantee must submit an Indirect Cost Rate Proposal in accordance with federal and State regulations, in a format prescribed by Grantor. For grantees who have never negotiated an Indirect Cost Rate before, the Indirect Cost Rate Proposal must be submitted for approval no later than three months after the effective date of the Award. For grantees who have previously negotiated an Indirect Cost Rate, the Indirect Cost Rate Proposal must be submitted for approval within 180 days of Grantee's fiscal year end, as dictated in the applicable appendices, such as:

(i) Appendix VII to 2 CFR Part 200 governs Indirect Cost Rate Proposals for state and Local Governments and Indian Tribes,

(ii) Appendix III to 2 CFR Part 200 governs Indirect Cost Rate Proposals for public and private institutions of higher education,

(iii) Appendix IV to 2 CFR Part 200 governs Indirect (F&A) Costs Identification and Assignment, and Rate Determination for Nonprofit Organizations, and

(iv) Appendix V to 2 CFR Part 200 governs state/Local Governmentwide Central Service Cost Allocation Plans.

(c) A grantee who has a current, applicable rate negotiated by a cognizant federal agency must provide to Grantor a copy of its Indirect Cost Rate acceptance letter from the federal government and a copy of all documentation regarding the allocation methodology for costs used to negotiate that rate, e.g., without limitation, the cost policy statement or disclosure narrative statement. Grantor will accept that Indirect Cost Rate, up to any statutory, rule-based or programmatic limit.

(d) A grantee who does not have a current negotiated rate, may elect to charge a de minimis rate of 10% of Modified Total Direct Cost which may be used indefinitely. No documentation is required to justify the 10% de minimis Indirect Cost Rate. 2 CFR 200.414(f).

7.3. Transfer of Costs. Cost transfers between Grants, whether as a means to compensate for cost overruns or for other reasons, are unallowable. 2 CFR 200.451.

7.4. Commercial Organization Cost Principles. The federal cost principles and procedures for cost analysis and the determination, negotiation and allowance of costs that apply to commercial organizations are set forth in 48 CFR Part 31.

7.5. Financial Management Standards. The financial management systems of Grantee must meet the following standards:

(a) **Accounting System.** Grantee organizations must have an accounting system that provides accurate, current, and complete disclosure of all financial transactions related to each state- and federally-funded Program. Accounting records must contain information pertaining to State and federal pass-through awards, authorizations, Obligations, unobligated balances, assets, outlays, and income. These records must be maintained on a current basis and balanced at least quarterly. Cash contributions to the Program from third parties must be accounted for in the general ledger with other Grant Funds. Third party in-kind (non-cash) contributions are not required to be recorded in the general ledger, but must be under accounting control, possibly through the use of a memorandum ledger. To comply with 2 CFR 200.305(b)(7)(i) and 30 ILCS 708/97, Grantee must use reasonable efforts to ensure that funding streams are delineated within Grantee's accounting system. 2 CFR 200.302.

(b) **Source Documentation.** Accounting records must be supported by such source documentation as canceled checks, bank statements, invoices, paid bills, donor letters, time and attendance records, activity reports, travel reports, contractual and consultant agreements, and subaward documentation. All supporting documentation must be clearly identified with the Award and general ledger accounts which are to be charged or credited.

(i) The documentation standards for salary charges to Grants are prescribed by 2 CFR 200.430, and in the cost principles applicable to the Grantee's organization.

(ii) If records do not meet the standards in 2 CFR 200.430, then Grantor may notify Grantee in **PART TWO, PART THREE** or **Exhibit E** of the requirement to submit personnel activity reports. 2 CFR 200.430(i)(8). Personnel activity reports must account on an after-the-fact basis for one hundred percent (100%) of the employee's actual time, separately indicating the time spent on the Award, other grants or projects, vacation or sick leave, and administrative time, if applicable. The reports must be signed by the employee, approved by the appropriate official, and coincide with a pay period. These time records must be used to record the distribution of salary costs to the appropriate accounts no less frequently than quarterly.

(iii) Formal agreements with independent contractors, such as consultants, must include a description of the services to be performed, the period of performance, the fee and method of payment, an itemization of travel and other costs which are chargeable to the agreement, and the signatures of both the contractor and an appropriate official of Grantee.

(iv) If third party in-kind (non-cash) contributions are used for Award purposes, the valuation of these contributions must be supported with adequate documentation.

(c) **Internal Control.** Grantee must maintain effective control and accountability for all cash, real and personal property, and other assets. Grantee must adequately safeguard all such property and must provide assurance that it is used solely for authorized purposes. Grantee must also have systems in place that provide reasonable assurance that the information is accurate, allowable, and compliant with the terms and conditions of this Agreement. 2 CFR 200.303.

(d) **Budget Control.** Grantee must maintain records of expenditures for each Award by the cost categories of the approved Budget (including Indirect Costs that are charged to the Award), and actual expenditures are to be compared with budgeted amounts at least quarterly.

(e) **Cash Management.** Requests for advance payment must be limited to Grantee's immediate cash needs. Grantee must have written procedures to minimize the time elapsing between the receipt and the disbursement of Grant Funds to avoid having excess funds on hand. 2 CFR 200.305.

7.6. **Profits.** It is not permitted for any person or entity to earn a Profit from an Award. See, e.g., 2 CFR 200.400(g); see also 30 ILCS 708/60(a)(7).

7.7. **Management of Program Income.** Grantee is encouraged to earn income to defray Program Costs where appropriate, subject to 2 CFR 200.307.

ARTICLE VIII LOBBYING

8.1. **Improper Influence.** Grantee certifies that it will not use and has not used Grant Funds to influence or attempt to influence an officer or employee of any government agency or a member or employee of the State or federal legislature in connection with the awarding of any agreement, the making of any grant, the making of any loan, the entering into of any cooperative agreement, or the extension, continuation, renewal, amendment or modification of any agreement, grant, loan or cooperative agreement. Additionally, Grantee certifies that it has filed the required certification under the Byrd Anti-Lobbying Amendment (31 USC 1352), if applicable.

8.2. **Federal Form LLL.** If any federal funds, other than federally-appropriated funds, were paid or will be paid to any person for influencing or attempting to influence any of the above persons in connection with this Agreement, the undersigned must also complete and submit Federal Form LLL, Disclosure of Lobbying Activities Form, in accordance with its instructions.

8.3. **Lobbying Costs.** Grantee certifies that it is in compliance with the restrictions on lobbying set forth in 2 CFR 200.450. For any Indirect Costs associated with this Agreement, total lobbying costs must be separately identified in the Program Budget, and thereafter treated as other Unallowable Costs.

8.4. **Procurement Lobbying.** Grantee warrants and certifies that it and, to the best of its knowledge, its subrecipients have complied and will comply with Illinois Executive Order No. 1 (2007) (EO 1-2007). EO 1-2007 generally prohibits grantees and subcontractors from hiring the then-serving Governor's family members to lobby procurement activities of the State, or any other unit of government in Illinois including local governments, if that procurement may result in a contract valued at over \$25,000. This prohibition also applies to hiring for that same purpose any former State employee who had procurement authority at any time during the one-year period preceding the procurement lobbying activity.

8.5. **Subawards.** Grantee must include the language of this ARTICLE in the award documents for any subawards made pursuant to this Award at all tiers. All subrecipients are also subject to certification and disclosure. Pursuant to Appendix II(l) to 2 CFR Part 200, Grantee must forward all disclosures by contractors regarding this certification to Grantor.

8.6. **Certification.** This certification is a material representation of fact upon which reliance was placed to enter into this transaction and is a prerequisite for this transaction, pursuant to 31 USC 1352. Any person who fails to file the required certifications will be subject to a civil penalty of not less than \$10,000, and not more than \$100,000, for each such failure.

**ARTICLE IX
MAINTENANCE AND ACCESSIBILITY OF RECORDS; MONITORING**

9.1. Records Retention. Grantee must maintain for three (3) years from the date of submission of the final expenditure report, adequate books, all financial records and, supporting documents, statistical records, and all other records pertinent to this Award, adequate to comply with 2 CFR 200.334, unless a different retention period is specified in 2 CFR 200.334, 44 Ill. Admin. Code 7000.430(a) and (b) or **PART TWO** or **PART THREE**. If any litigation, claim or audit is started before the expiration of the retention period, the records must be retained until all litigation, claims or audit exceptions involving the records have been resolved and final action taken.

9.2. Accessibility of Records. Grantee, in compliance with 2 CFR 200.337 and 44 Ill. Admin. Code 7000.430(f), must make books, records, related papers, supporting documentation and personnel relevant to this Agreement available to authorized Grantor representatives, the Illinois Auditor General, Illinois Attorney General, any Executive Inspector General, Grantor's Inspector General, federal authorities, any person identified in 2 CFR 200.337, and any other person as may be authorized by Grantor (including auditors), by the State of Illinois or by federal statute. Grantee must cooperate fully in any such audit or inquiry.

9.3. Failure to Maintain Books and Records. Failure to maintain books, records and supporting documentation, as described in this ARTICLE, establishes a presumption in favor of the State for the recovery of any Grant Funds paid by the State under this Agreement for which adequate books, records and supporting documentation are not available to support disbursement.

9.4. Monitoring and Access to Information. Grantee must monitor its activities to assure compliance with applicable state and federal requirements and to assure its performance expectations are being achieved. Grantor will monitor the activities of Grantee to assure compliance with all requirements and performance expectations of the Award. Grantee must timely submit all financial and performance reports, and must supply, upon Grantor's request, documents and information relevant to the Award. Grantor may make site visits as warranted by Program needs. 2 CFR 200.329; 200.332. Additional monitoring requirements may be in **PART TWO** or **PART THREE**.

**ARTICLE X
FINANCIAL REPORTING REQUIREMENTS**

10.1. Required Periodic Financial Reports. Grantee must submit financial reports as requested and in the format required by Grantor no later than the dues date(s) specified in **PART TWO** or **PART THREE**. Grantee must submit quarterly reports with Grantor describing the expenditure(s) of the funds related thereto, unless more frequent reporting is required by the Grantee due to the funding source or pursuant to specific award conditions. 2 CFR 200.208. Any report required by 30 ILCS 708/125 may be detailed in **PART TWO** or **PART THREE**.

10.2. Financial Close-out Report.

(a) Grantee must submit a financial Close-out Report, in the format required by Grantor, by the due date specified in **PART TWO** or **PART THREE**, which must be no later than sixty (60) calendar days following the end of the Period of Performance for this Agreement or Agreement termination. The format of this financial Close-out Report must follow a format prescribed by Grantor. 2 CFR 200.344; 44 Ill. Admin. Code 7000.440(b).

(b) If an audit or review of Grantee occurs and results in adjustments after Grantee submits a Close-out Report, Grantee must submit a new financial Close-out Report based on audit adjustments, and immediately submit a refund to Grantor, if applicable. 2 CFR 200.345; 44 Ill. Admin. Code 7000.450.

10.3. Effect of Failure to Comply. Failure to comply with the reporting requirements in this Agreement may cause a delay or suspension of funding or require the return of improper payments or Unallowable Costs, and will be considered a material breach of this Agreement. Grantee's failure to comply with ARTICLE X, ARTICLE XI, or ARTICLE XVII will be considered prima facie evidence of a breach and may be admitted as such, without further proof, into evidence in an administrative proceeding before Grantor, or in any other legal proceeding. Grantee should refer to the State Grantee Compliance Enforcement System for policy and consequences for failure to comply. 44 Ill. Admin. Code 7000.80.

ARTICLE XI PERFORMANCE REPORTING REQUIREMENTS

11.1. Required Periodic Performance Reports. Grantee must submit performance reports as requested and in the format required by Grantor no later than the due date(s) specified in **PART TWO** or **PART THREE**. 44 Ill. Admin. Code 7000.410. Grantee must report to Grantor on the performance measures listed in **Exhibit D, PART TWO** or **PART THREE** at the intervals specified by Grantor, which must be no less frequent than annually and no more frequent than quarterly, unless otherwise specified in **PART TWO, PART THREE**, or **Exhibit E** pursuant to specific award conditions. For certain construction-related Awards, such reports may be exempted as identified in **PART TWO** or **PART THREE**. 2 CFR 200.329.

11.2. Performance Close-out Report. Grantee must submit a performance Close-out Report, in the format required by Grantor by the due date specified in **PART TWO** or **PART THREE**, which must be no later than 60 calendar days following the end of the Period of Performance or Agreement termination. 2 CFR 200.344; 44 Ill. Admin. Code 7000.440(b).

11.3. Content of Performance Reports. Pursuant to 2 CFR 200.329(b) and (c), all performance reports must relate the financial data and accomplishments to the performance goals and objectives of this Award and also include the following: a comparison of actual accomplishments to the objectives of the Award established for the period; where the accomplishments can be quantified, a computation of the cost and demonstration of cost effective practices (e.g., through unit cost data); performance trend data and analysis if required; and reasons why established goals were not met, if appropriate. Additional content and format guidelines for the performance reports will be determined by Grantor contingent on the Award's statutory, regulatory and administrative requirements, and are included in **PART TWO** or **PART THREE** of this Agreement.

ARTICLE XII AUDIT REQUIREMENTS

12.1. Audits. Grantee is subject to the audit requirements contained in the Single Audit Act Amendments of 1996 (31 USC 7501-7507), Subpart F of 2 CFR Part 200, and the audit rules and policies set forth by the Governor's Office of Management and Budget. 30 ILCS 708/65(c); 44 Ill. Admin. Code 7000.90.

12.2. Consolidated Year-End Financial Reports (CYEFR). All grantees must complete and submit a CYEFR through the Grantee Portal, except those exempted by federal or State statute or regulation, as set forth in **PART TWO** or **PART THREE**. The CYEFR is a required schedule in Grantee's audit report if Grantee is required to complete and submit an audit report as set forth herein.

(a) Grantee's CYEFR must cover the same period as the audited financial statements, if required, and must be submitted in accordance with the audit schedule at 44 Ill. Admin. Code 7000.90. If Grantee is not required to complete audited financial statements, the CYEFR must cover Grantee's fiscal year and must be submitted within 6 months of the Grantee's fiscal year-end.

(b) The CYEFR must include an in relation to opinion from the auditor of the financial statements included in the audit.

(c) The CYEFR must follow a format prescribed by Grantor.

12.3. Entities That Are Not "For-Profit".

(a) This Paragraph applies to Grantees that are not "for-profit" entities.

(b) Single and Program-Specific Audits. If, during its fiscal year, Grantee expends \$750,000 or more in federal Awards (direct federal and federal pass-through awards combined), Grantee must have a single audit or program-specific audit conducted for that year as required by 2 CFR 200.501 and other applicable sections of Subpart F of 2 CFR Part 200. The audit report packet must be completed as described in 2 CFR 200.512 (single audit) or 2 CFR 200.507 (program-specific audit), 44 Ill. Admin. Code 7000.90(h)(1) and the current GATA audit manual and submitted to the Federal Audit Clearinghouse, as required by 2 CFR 200.512. The results of peer and external quality control reviews, management letters issued by the auditors and their respective corrective action plans if significant deficiencies or material weaknesses are identified, and the CYEFR(s) must be submitted to the Grantee Portal. The due date of all required submissions set forth in this Paragraph is the earlier of (i) thirty (30) calendar days after receipt of the auditor's report(s) or (ii) nine (9) months after the end of Grantee's audit period.

(c) Financial Statement Audit. If, during its fiscal year, Grantee expends less than \$750,000 in federal Awards, Grantee is subject to the following audit requirements:

(i) If, during its fiscal year, Grantee expends \$500,000 or more in State-issued Awards, Grantee must have a financial statement audit conducted in accordance with the Generally Accepted Government Auditing Standards (GAGAS). Grantee may be subject to additional requirements in **PART TWO**, **PART THREE** or **Exhibit E** based on Grantee's risk profile.

(ii) If, during its fiscal year, Grantee expends less than \$500,000 in State-issued Awards, but expends \$300,000 or more in State-issued Awards, Grantee must have a financial statement audit conducted in accordance with the Generally Accepted Auditing Standards (GAAS).

(iii) If Grantee is a Local Education Agency (as defined in 34 CFR 77.1), Grantee must have a financial statement audit conducted in accordance with GAGAS, as required by 23 Ill. Admin. Code 100.110, regardless of the dollar amount of expenditures of State-issued Awards.

(iv) If Grantee does not meet the requirements in subsections 12.3(b) and 12.3(c)(i-iii) but is required to have a financial statement audit conducted based on other regulatory requirements, Grantee must submit those audits for review.

(v) Grantee must submit its financial statement audit report packet, as set forth in 44 Ill. Admin. Code 7000.90(h)(2) and the current GATA audit manual, to the Grantee Portal within the earlier of (i) thirty (30) calendar days after receipt of the auditor's report(s) or (ii) six (6) months after the end of Grantee's audit period.

12.4. "For-Profit" Entities.

(a) This Paragraph applies to Grantees that are "for-profit" entities.

(b) Program-Specific Audit. If, during its fiscal year, Grantee expends \$750,000 or more in federal pass-through funds from State-issued Awards, Grantee must have a program-specific audit conducted in accordance with 2 CFR 200.507. The auditor must audit federal pass-through programs with federal pass-through Awards expended that, in the aggregate, cover at least 50 percent (0.50) of total federal pass-through Awards expended. The audit report packet must be completed as described in 2 CFR 200.507 (program-specific audit), 44 Ill. Admin. Code 7000.90 and the current GATA audit manual, and

must be submitted to the Grantee Portal. The due date of all required submissions set forth in this Paragraph is the earlier of (i) thirty (30) calendar days after receipt of the auditor's report(s) or (ii) nine (9) months after the end of Grantee's audit period.

(c) **Financial Statement Audit.** If, during its fiscal year, Grantee expends less than \$750,000 in federal pass-through funds from State-issued Awards, Grantee must follow all of the audit requirements in Paragraphs 12.3(c)(i)-(v), above.

(d) **Publicly-Traded Entities.** If Grantee is a publicly-traded company, Grantee is not subject to the single audit or program-specific audit requirements, but must submit its annual audit conducted in accordance with its regulatory requirements.

12.5. **Performance of Audits.** For those organizations required to submit an independent audit report, the audit must be conducted by the Illinois Auditor General (as required for certain governmental entities only), or a Certified Public Accountant or Certified Public Accounting Firm licensed in the State of Illinois or in accordance with Section 5.2 of the Illinois Public Accounting Act (225 ILCS 450/5.2). For all audits required to be performed subject to GAGAS or Generally Accepted Auditing Standards, Grantee must request and maintain on file a copy of the auditor's most recent peer review report and acceptance letter. Grantee must follow procedures prescribed by Grantor for the preparation and submission of audit reports and any related documents.

12.6. **Delinquent Reports.** When audit reports or financial statements required under this ARTICLE are prepared by the Illinois Auditor General, if they are not available by the above-specified due date, they must be provided to Grantor within thirty (30) days of becoming available. Grantee should refer to the State Grantee Compliance Enforcement System for the policy and consequences for late reporting. 44 Ill. Admin. Code 7000.80.

ARTICLE XIII TERMINATION; SUSPENSION; NON-COMPLIANCE

13.1. **Termination.**

(a) Either Party may terminate this Agreement, in whole or in part, upon thirty (30) calendar days' prior written notice to the other Party.

(b) If terminated by the Grantee, Grantee must include the reasons for such termination, the effective date, and, in the case of a partial termination, the portion to be terminated. If Grantor determines in the case of a partial termination that the reduced or modified portion of the Award will not accomplish the purposes for which the Award was made, Grantor may terminate the Agreement in its entirety. 2 CFR 200.340(a)(4).

(c) This Agreement may be terminated, in whole or in part, by Grantor:

(i) Pursuant to a funding failure under Paragraph 4.1;

(ii) If Grantee fails to comply with the terms and conditions of this or any Award, application or proposal, including any applicable rules or regulations, or has made a false representation in connection with the receipt of this or any Award; or

(iii) If the Award no longer effectuates the Program goals or agency priorities as set forth in **Exhibit A, PART TWO** or **PART THREE**.

13.2. **Suspension.** Grantor may suspend this Agreement, in whole or in part, pursuant to a funding failure under Paragraph 4.1 or if the Grantee fails to comply with terms and conditions of this or any Award. If

suspension is due to Grantee's failure to comply, Grantor may withhold further payment and prohibit Grantee from incurring additional Obligations pending corrective action by Grantee or a decision to terminate this Agreement by Grantor. Grantor may allow necessary and proper costs that Grantee could not reasonably avoid during the period of suspension.

13.3. Non-compliance. If Grantee fails to comply with the U.S. Constitution, applicable statutes, regulations or the terms and conditions of this or any Award, Grantor may impose additional conditions on Grantee, as described in 2 CFR 200.208. If Grantor determines that non-compliance cannot be remedied by imposing additional conditions, Grantor may take one or more of the actions described in 2 CFR 200.339. The Parties must follow all Grantor policies and procedures regarding non-compliance, including, but not limited to, the procedures set forth in the State Grantee Compliance Enforcement System. 44 Ill. Admin. Code 7000.80 and 7000.260.

13.4. Objection. If Grantor suspends or terminates this Agreement, in whole or in part, for cause, or takes any other action in response to Grantee's non-compliance, Grantee may avail itself of any opportunities to object and challenge such suspension, termination or other action by Grantor in accordance with any applicable processes and procedures, including, but not limited to, the procedures set forth in the State Grantee Compliance Enforcement System. 2 CFR 200.342; 44 Ill. Admin. Code 7000.80 and 7000.260.

13.5. Effects of Suspension and Termination.

(a) Grantor may credit Grantee for allowable expenditures incurred in the performance of authorized services under this Agreement prior to the effective date of a suspension or termination.

(b) Except as set forth in subparagraph (c), below, Grantee must not incur any costs or Obligations that require the use of Grant Funds after the effective date of a suspension or termination, and must cancel as many outstanding Obligations as possible.

(c) Costs to Grantee resulting from Obligations incurred by Grantee during a suspension or after termination of the Agreement are not allowable unless Grantor expressly authorizes them in the notice of suspension or termination or subsequently. However, Grantor may allow costs during a suspension or after termination if:

(i) The costs result from Obligations properly incurred before the effective date of suspension or termination, are not in anticipation of the suspension or termination, and the costs would be allowable if the Agreement was not suspended or terminated prematurely. 2 CFR 200.343.

13.6. Close-out of Terminated Agreements. If this Agreement is terminated, in whole or in part, the Parties must comply with all close-out and post-termination requirements of this Agreement. 2 CFR 200.340(d).

**ARTICLE XIV
SUBCONTRACTS/SUBAWARDS**

14.1. Subcontracting/Subrecipients/Delegation. Grantee must not subcontract nor issue a subaward for any portion of this Agreement nor delegate any duties hereunder without Prior Approval of Grantor. The requirement for Prior Approval is satisfied if the subcontractor or subrecipient has been identified in the uniform grant application, such as, without limitation, a Project description, and Grantor has approved. Grantee must notify any potential subrecipient that the subrecipient must obtain and provide to the Grantee a Unique Entity Identifier prior to receiving a subaward. 2 CFR 25.300.

14.2. Application of Terms. If Grantee enters into a subaward agreement with a subrecipient, Grantee must notify the subrecipient of the applicable laws and regulations and terms and conditions of this Award by attaching this Agreement to the subaward agreement. The terms of this Agreement apply to all subawards authorized in accordance with Paragraph 14.1. 2 CFR 200.101(b)(2).

14.3. Liability as Guaranty. Grantee will be liable as guarantor for any Grant Funds it obligates to a subrecipient or subcontractor pursuant to this ARTICLE in the event Grantor determines the funds were either misspent or are being improperly held and the subrecipient or subcontractor is insolvent or otherwise fails to return the funds. 2 CFR 200.345; 30 ILCS 705/6; 44 Ill. Admin. Code 7000.450(a).

ARTICLE XV NOTICE OF CHANGE

15.1. Notice of Change. Grantee must notify Grantor if there is a change in Grantee's legal status, FEIN, UEI, SAM registration status, Related Parties, senior management (for non-governmental grantees only) or address. If the change is anticipated, Grantee must give thirty (30) days' prior written notice to Grantor. If the change is unanticipated, Grantee must give notice as soon as practicable thereafter. Grantor reserves the right to take any and all appropriate action as a result of such change(s).

15.2. Failure to Provide Notification. To the extent permitted by Illinois law (see Paragraph 21.2), Grantee must hold harmless Grantor for any acts or omissions of Grantor resulting from Grantee's failure to notify Grantor as required by Paragraph 15.1.

15.3. Notice of Impact. Grantee must notify Grantor in writing of any event, including, by not limited to, becoming a party to litigation, an investigation, or transaction that may have a material impact on Grantee's ability to perform under this Agreement. Grantee must provide notice to Grantor as soon as possible, but no later than five (5) days after Grantee becomes aware that the event may have a material impact.

15.4. Effect of Failure to Provide Notice. Failure to provide the notice described in this ARTICLE is grounds for termination of this Agreement and any costs incurred after the date notice should have been given may be disallowed.

ARTICLE XVI STRUCTURAL REORGANIZATION AND RECONSTITUTION OF BOARD MEMBERSHIP

16.1. Effect of Reorganization. This Agreement is made by and between Grantor and Grantee, as Grantee is currently organized and constituted. Grantor does not agree to continue this Agreement, or any license related thereto, should Grantee significantly reorganize or otherwise substantially change the character of its corporate structure, business structure or governance structure. Grantee must give Grantor prior notice of any such action or changes significantly affecting its overall structure or, for non-governmental grantees only, management makeup (for example, a merger or a corporate restructuring), and must provide all reasonable documentation necessary for Grantor to review the proposed transaction including financial records and corporate and shareholder minutes of any corporation which may be involved. Grantor reserves the right to terminate the Agreement based on whether the newly organized entity is able to carry out the requirements of the Award. This ARTICLE does not require Grantee to report on minor changes in the makeup of its board membership or governance structure, as applicable. Nevertheless, **PART TWO** or **PART THREE** may impose further restrictions. Failure to comply with this ARTICLE constitutes a material breach of this Agreement.

ARTICLE XVII CONFLICT OF INTEREST

17.1. Required Disclosures. Grantee must immediately disclose in writing any potential or actual Conflict of Interest to Grantor. 2 CFR 200.113; 30 ILCS 708/35.

17.2. Prohibited Payments. Payments made by Grantor under this Agreement must not be used by Grantee to compensate, directly or indirectly, any person currently holding an elective office in this State including, but not limited to, a seat in the General Assembly. In addition, where Grantee is not an instrumentality of the State of Illinois, as described in this Paragraph, Grantee must request permission from Grantor to compensate, directly or indirectly, any person employed by an office or agency of the State of Illinois. An instrumentality of the State of Illinois includes, without limitation, State departments, agencies, boards, and State universities. An instrumentality of the State of Illinois does not include, without limitation, units of Local Government and related entities.

17.3. Request for Exemption. Grantee may request written approval from Grantor for an exemption from Paragraph 17.2. Grantee acknowledges that Grantor is under no obligation to provide such exemption and that Grantor may grant an such exemption subject to additional terms and conditions as Grantor may require.

ARTICLE XVIII EQUIPMENT OR PROPERTY

18.1. Purchase of Equipment. For any equipment purchased in whole or in part with Grant Funds, if Grantor determines that Grantee has not met the conditions of 2 CFR 200.439, the costs for such equipment will be disallowed. Grantor must notify Grantee in writing that the purchase of equipment is disallowed.

18.2. Prohibition against Disposition/Encumbrance. Any equipment, material, or real property that Grantee purchases or improves with Grant Funds must not be sold, transferred, encumbered (other than original financing) or otherwise disposed of during the Award Term without Prior Approval of Grantor unless a longer period is required in **PART TWO** or **PART THREE** and permitted by 2 CFR Part 200 Subpart D. Use or disposition of real property acquired or improved using Grant Funds must comply with the requirements of 2 CFR 200.311. Real property, equipment, and intangible property that are acquired or improved in whole or in part using Grant Funds are subject to the provisions of 2 CFR 200.316. Grantor may require the Grantee to record liens or other appropriate notices of record to indicate that personal or real property has been acquired or improved with this Award and that use and disposition conditions apply to the property.

18.3. Equipment and Procurement. Grantee must comply with the uniform standards set forth in 2 CFR 200.310–200.316 governing the management and disposition of property, the cost of which was supported by Grant Funds. Any waiver from such compliance must be granted by either the President's Office of Management and Budget, the Governor's Office of Management and Budget, or both, depending on the source of the Grant Funds used. Additionally, Grantee must comply with the standards set forth in 2 CFR 200.317-200.326 to establish procedures to use Grant Funds for the procurement of supplies and other expendable property, equipment, real property and other services.

18.4. Equipment Instructions. Grantee must obtain disposition instructions from Grantor when equipment, purchased in whole or in part with Grant Funds, is no longer needed for their original purpose. Notwithstanding anything to the contrary contained in this Agreement, Grantor may require transfer of any equipment to Grantor or a third party for any reason, including, without limitation, if Grantor terminates the Award or Grantee no longer conducts Award activities. Grantee must properly maintain, track, use, store and insure the equipment according to applicable best practices, manufacturer's guidelines, federal and state laws or rules, and Grantor requirements stated herein.

18.5. Domestic Preferences for Procurements. In accordance with 2 CFR 200.322, as appropriate and to the extent consistent with law, Grantee must, to the greatest extent practicable under this Award, provide a

preference for the purchase, acquisition, or use of goods, products, or materials produced in the United States (including but not limited to iron, aluminum, steel, cement, and other manufactured products). The requirements of this Paragraph must be included in all subawards and in all contracts and purchase orders for work or products under this Award.

ARTICLE XIX PROMOTIONAL MATERIALS; PRIOR NOTIFICATION

19.1. Promotional and Written Materials. Use of Grant Funds for promotions is subject to the prohibitions for advertising or public relations costs in 2 CFR 200.421(e). In the event that Grant Funds are used in whole or in part to produce any written publications, announcements, reports, flyers, brochures or other written materials, Grantee must obtain Prior Approval for the use of those funds (2 CFR 200.467) and must include in these publications, announcements, reports, flyers, brochures and all other such material, the phrase "Funding provided in whole or in part by the [Grantor]." 2 CFR 200.467. Exceptions to this requirement must be requested, in writing, from Grantor and will be considered authorized only upon written notice thereof to Grantee.

19.2. Prior Notification/Release of Information. Grantee must notify Grantor ten (10) days prior to issuing public announcements or press releases concerning work performed pursuant to this Agreement, or funded in whole or in part by this Agreement, and must cooperate with Grantor in joint or coordinated releases of information.

ARTICLE XX INSURANCE

20.1. Maintenance of Insurance. Grantee must maintain in full force and effect during the Term of this Agreement casualty and bodily injury insurance, as well as insurance sufficient to cover the replacement cost of any and all real or personal property, or both, purchased or, otherwise acquired, or improved in whole or in part, with funds disbursed pursuant to this Agreement. 2 CFR 200.310. Additional insurance requirements may be detailed in **PART TWO** or **PART THREE**.

20.2. Claims. If a claim is submitted for real or personal property, or both, purchased in whole with funds from this Agreement and such claim results in the recovery of money, such money recovered must be surrendered to Grantor.

ARTICLE XXI LAWSUITS AND INDEMNIFICATION

21.1. Independent Contractor. Neither Grantee nor any employee or agent of Grantee acquires any employment rights with Grantor by virtue of this Agreement. Grantee must provide the agreed services and achieve the specified results free from the direction or control of Grantor as to the means and methods of performance. Grantee must provide its own equipment and supplies necessary to conduct its business; provided, however, that in the event, for its convenience or otherwise, Grantor makes any such equipment or supplies available to Grantee, Grantee's use of such equipment or supplies provided by Grantor pursuant to this Agreement is strictly limited to official Grantor or State of Illinois business and not for any other purpose, including any personal benefit or gain.

21.2. Indemnification and Liability.

(a) Non-governmental entities. This subparagraph applies only if Grantee is a non-governmental entity. Grantee must hold harmless Grantor against any and all liability, loss, damage, cost

or expenses, including attorneys' fees, arising from the intentional torts, negligence or breach of contract of Grantee, with the exception of acts performed in conformance with an explicit, written directive of Grantor. Indemnification by Grantor is governed by the State Employee Indemnification Act (5 ILCS 350/.01 et seq.) as interpreted by the Illinois Attorney General. Grantor makes no representation that Grantee, an independent contractor, will qualify or be eligible for indemnification under said Act.

(b) Governmental entities. This subparagraph applies only if Grantee is a governmental unit as designated in Paragraph 3.2. Neither Party shall be liable for actions chargeable to the other Party under this Agreement including, but not limited to, the negligent acts and omissions of the other Party's agents, employees or subcontractors in the performance of their duties as described under this Agreement, unless such liability is imposed by law. This Agreement is not construed as seeking to enlarge or diminish any obligation or duty owed by one Party against the other or against a third party.

ARTICLE XXII MISCELLANEOUS

22.1. Gift Ban. Grantee is prohibited from giving gifts to State employees pursuant to the State Officials and Employees Ethics Act (5 ILCS 430/10-10) and Illinois Executive Order 15-09.

22.2. Assignment Prohibited. This Agreement must not be sold, assigned, or transferred in any manner by Grantee, to include an assignment of Grantee's rights to receive payment hereunder, and any actual or attempted sale, assignment, or transfer by Grantee without the Prior Approval of Grantor in writing renders this Agreement null, void and of no further effect.

22.3. Copies of Agreements upon Request. Grantee must, upon request by Grantor, provide Grantor with copies of contracts or other agreements to which Grantee is a party with any other State agency.

22.4. Amendments. This Agreement may be modified or amended at any time during its Term by mutual consent of the Parties, expressed in writing and signed by the Parties.

22.5. Severability. If any provision of this Agreement is declared invalid, its other provisions will remain in effect.

22.6. No Waiver. The failure of either Party to assert any right or remedy pursuant to this Agreement will not be construed as a waiver of either Party's right to assert such right or remedy at a later time or constitute a course of business upon which either Party may rely for the purpose of denial of such a right or remedy.

22.7. Applicable Law; Claims. This Agreement and all subsequent amendments thereto, if any, are governed and construed in accordance with the laws of the State of Illinois. Any claim against Grantor arising out of this Agreement must be filed exclusively with the Illinois Court of Claims. 705 ILCS 505/1 et seq. Grantor does not waive sovereign immunity by entering into this Agreement.

22.8. Compliance with Law. This Agreement and Grantee's Obligations and services hereunder must be performed in compliance with all applicable federal and State laws, including, without limitation, federal regulations, State administrative rules, including but not limited to 44 Ill. Admin. Code Part 7000, laws and rules which govern disclosure of confidential records or other information obtained by Grantee concerning persons served under this Agreement, and any license requirements or professional certification provisions.

22.9. Compliance with Freedom of Information Act. Upon request, Grantee must make available to Grantor all documents in its possession that Grantor deems necessary to comply with requests made under the Freedom of Information Act. 5 ILCS 140/7(2).

22.10. Precedence.

(a) Except as set forth in subparagraph (b), below, the following rules of precedence are controlling for this Agreement: In the event there is a conflict between this Agreement and any of the exhibits or attachments hereto, this Agreement controls. In the event there is a conflict between **PART ONE** and **PART TWO** or **PART THREE** of this Agreement, **PART ONE** controls. In the event there is a conflict between **PART TWO** and **PART THREE** of this Agreement, **PART TWO** controls. In the event there is a conflict between this Agreement and relevant statute(s) or rule(s), the relevant statute(s) or rule(s) controls.

(b) Notwithstanding the provisions in subparagraph (a), above, if a relevant federal or state statute(s) or rule(s) requires an exception to this Agreement's provisions, or an exception to a requirement in this Agreement is granted by GATU, such exceptions must be noted in **PART TWO** or **PART THREE**, and in such cases, those requirements control.

22.11. Illinois Grant Funds Recovery Act. In the event of a conflict between the Illinois Grant Funds Recovery Act and the Grant Accountability and Transparency Act, the provisions of the Grant Accountability and Transparency Act control. 30 ILCS 708/80.

22.12. Headings. Articles and other headings contained in this Agreement are for reference purposes only and are not intended to define or limit the scope, extent or intent of this Agreement or any provision hereof.

22.13. Counterparts. This Agreement may be executed in one or more counterparts, each of which are considered to be one and the same agreement, binding on all Parties hereto, notwithstanding that all Parties are not signatories to the same counterpart. Duplicated signatures, signatures transmitted via facsimile, or signatures contained in a Portable Document Format (PDF) document are deemed original for all purposes.

22.14. Attorney Fees and Costs. Unless prohibited by law, if Grantor prevails in any proceeding to enforce the terms of this Agreement, including any administrative hearing pursuant to the Grant Funds Recovery Act or the Grant Accountability and Transparency Act, Grantor has the right to recover reasonable attorneys' fees, costs and expenses associated with such proceedings.

22.15. Continuing Responsibilities. The termination or expiration of this Agreement does not affect: (a) the right of Grantor to disallow costs and recover funds based on a later audit or other review; (b) the obligation of the Grantee to return any funds due as a result of later refunds, corrections or other transactions, including, without limitation, final Indirect Cost Rate adjustments and those funds obligated pursuant to ARTICLE XIV; (c) the CYEFR(s); (d) audit requirements established in 44 Ill. Admin. Code 7000.90 and ARTICLE XII; (e) property management and disposition requirements established in 2 CFR 200.310 through 2 CFR 200.316 and ARTICLE XVIII; or (f) records related requirements pursuant to ARTICLE IX. 44 Ill. Admin. Code 7000.440.

THE REMAINDER OF THIS PAGE IS INTENTIONALLY LEFT BLANK.

EXHIBIT A

PROJECT DESCRIPTION

Grantee must complete the Award Activities described on this **Exhibit A**, the Deliverables and Milestones listed on **Exhibit B** and the Performance Measures listed on **Exhibit D** within the term of this Agreement, as provided in Paragraph 2.1, herein.

AUTHORITY: The Grantor is authorized to make this Award pursuant to 20 ILCS 605/605-55 and/or 20 ILCS 605/605-30.

The purpose of this authority is as follows:

To make & enter into contracts, including grants, as authorized pursuant to appropriations by the General Assembly &/or to use State & federal programs, grants, & subsidies that are available to assist in discharge of the provisions of the Civil Administrative Code of Illinois.

PROJECT DESCRIPTION:

The Grantee is a governmental entity providing services to residents of the Village of Villa Park in DuPage County.

Grant funds will be utilized for a portion of the costs, including any that are prior incurred, associated with the implementation of various stormwater improvements at multiple locations within the corporate limits of the Grantee. Grant funds will be used for the purchase and installation of storm sewers, manholes, catch basins, associated pavement restoration, and nonpaved area grading and restoration at various locations. The project is necessary to reduce flooding and improve stormwater drainage to prevent further damage to residential and commercial properties. Unless otherwise determined by the Department, this award is considered to be covered by Expenditure Category 5.6 (Clean Water- Stormwater) as identified within the associated federal guidance. All other costs associated with the completion of the project will be paid via the use of other funding sources.

Specifically, Grant funds will include a portion of the costs associated with the project as follows:

Paving/Concrete/Masonry – to include costs associated with the purchase and installation of asphalt and concrete for replacement of removed pavement.

Excavation/Site Prep/Demo – to include costs associated with the excavation, grading and restoration of the project sites, including the purchase of topsoil, seed, and erosion blankets.

Plumbing – to include costs associated with the purchase and installation of storm sewers, catch basins, and manholes.

The completion of this project will benefit the public by providing flood mitigation and improved stormwater drainage for residents and businesses.

EXHIBIT B

DELIVERABLES OR MILESTONES

To be stated on the initial submitted Periodic Performance Report (PPR), as directed by the Report Deliverable Schedule, the Grantee will provide a detailed task list of projected deliverables, which must be approved by Grantor. These tasks and associated due dates, and any subsequent revisions, shall be incorporated by reference into this Agreement. These tasks will be used to measure performance throughout the life of the Award and can be updated and reported on each PPR reporting due date.

NOT FOR BID

EXHIBIT C

CONTACT INFORMATION

CONTACTS FOR NOTIFICATION AND GRANT ADMINISTRATION:

Unless specified elsewhere, all notices required or desired to be sent by either Party must be sent to the persons listed below. Grantee must notify Grantor of any changes in its contact information listed below within five (5) business days from the effective date of the change, and Grantor must notify Grantee of any changes to its contact information as soon as practicable. The Party making a change must send any changes in writing to the contact for the other Party. No amendment to this Agreement is required if information in this Exhibit is changed.

FOR OFFICIAL GRANT NOTIFICATIONS

GRANTOR CONTACT

Name: Kristin A. Richards
Title: Director
Address: 607 E. Adams St.
Springfield, IL 62701

GRANTEE CONTACT

Name: Matt Harline
Title: Village Manager
Address: 20 South Ardmore Avenue
Villa Park, IL 60181-2610

GRANTEE PAYMENT ADDRESS

(If different than the address above)

Address: N/A

FOR GRANT ADMINISTRATION

GRANTOR CONTACT

Name: Alex Fuller
Title: Grant Manager
Address: 607 E. Adams St.
Springfield, IL 62701
Phone: 217-782-9988
TTY#: (800) 785-6055
Email: Alex.Fuller@Illinois.gov
Address:

GRANTEE CONTACT

Name: Michael Guerra
Title: Director of Public Works
Address: 20 South Ardmore Avenue
Villa Park, IL 60181-2610
Phone: 630-834-8505
TTY#: N/A
Email: mguerra@invillapark.com
Address:

GRANTEE DESIGNEES

The following are designated as Authorized Designee(s) for the Grantee (See **PART TWO**, ARTICLE XXIII):

Authorized Designee: _____
Authorized Designee Title: _____
Authorized Designee Phone: _____
Authorized Designee Email: _____

Authorized Designee Signature: _____

Authorized Signatory Approval: _____

Authorized Designee: _____
Authorized Designee Title: _____
Authorized Designee Phone: _____
Authorized Designee Email: _____

Authorized Designee Signature: _____

Authorized Signatory Approval: _____

GRANTOR CONTACT FOR AUDIT OR CONSOLIDATED YEAR-END FINANCIAL REPORTS QUESTIONS—AUDIT UNIT

Email: externalauditunit@illinois.gov

GRANTOR CONTACT FOR FINANCIAL CLOSEOUT QUESTIONS—PROGRAM ACCOUNTANT

Name: Lucy Tankoua
Email: lucy.tankoua@illinois.gov
Phone: 000-000-0000
Fax#: N/A

Address: 607 E. Adams St.
Springfield, IL 62701

EXHIBIT D

PERFORMANCE MEASURES AND STANDARDS

To be stated on the initial submitted Periodic Performance Report (PPR), as directed by the Report Deliverable Schedule, the Grantee will incorporate project specific performance measures within the corresponding section of the PPR. The project specific performance measures will encompass the following standardized performance measures listed below.

- Did the deliverables specified in the task list submitted pursuant to Exhibit B lead to the completion of the project described in Exhibit A?
- Given the total amount of Grant Funds available, does the percent currently drawn and expended directly correlate to the percent of the completion of the project to date?
- At the time of Award closeout, has the Grantee fulfilled the public purpose of the project stated in Exhibit A?

The Grantor reserves the right to deny any voucher request(s) at its discretion, based on lack of progress toward meeting completion goals. If the Grantee fails to meet any of the performance measures/goals, and if deemed appropriate at the discretion of the Grantor, the Grant Funds may be decreased by an amount proportionate to the size of the shortfall, and/or the Grantee may be responsible for the return of the Grant Funds in the amount specified by the Grantor. Grantor may initiate a grant modification(s) to de-obligate Grant Funds based on non-performance. The Grantee will submit grant modification requests as necessary in a timely manner, including a request to de-obligate Grant Funds in an amount that the Grantee determines will be unspent by the end of the Grant Agreement Term.

EXHIBIT E

SPECIFIC CONDITIONS

Grantor may remove (or reduce) a Specific Condition included in this Exhibit by providing written notice to the Grantee, in accordance with established procedures for removing a Specific Condition.

There were no conditions resulting from the Internal Control Questionnaire (ICQ).

There were no conditions resulting from the Programmatic Risk Assessment.

NOT FOR BID

PART TWO – GRANTOR-SPECIFIC TERMS

In addition to the uniform requirements in **PART ONE**, Grantor has the following additional requirements for its Grantee:

**ARTICLE XXIII
AUTHORIZED SIGNATORY**

23.1. Authorized Signatory. In processing this Award and related documentation, Grantor will only accept materials signed by the Authorized Signatory or Designee of this Agreement, as designated or prescribed in the Grantee's signature block or on **Exhibit C**. If the Authorized Signatory chooses to assign a designee to sign or submit materials required by this Agreement to Grantor, the Authorized Signatory must either send written notice to Grantor indicating the name of the designee, or provide notice as set forth in **Exhibit C**. Without this notice, Grantor will reject any materials signed or submitted on the Grantee's behalf by anyone other than the Authorized Signatory. The Authorized Signatory must approve each Authorized Designee separately by signing as indicated on **Exhibit C** or on the appropriate form provided by Grantor. If an Authorized Designee(s) appears on **Exhibit C**, the Grantee should verify the information and indicate any changes as necessary. Signatures of both the Authorized Signatory and the Authorized Designee are required in order for the Authorized Designee to have signature authority under this Agreement.

**ARTICLE XXIV
ADDITIONAL AUDIT PROVISIONS**

24.1. Discretionary Audit. The Grantor may, at any time and in its sole discretion, require a program-specific audit, or other audit, SAS 115/AU-C265 letters (Auditor's Communication of Internal Control Related Matters) and SAS 114/AU-C260 letters (Auditor's Communication With Those Charged With Governance).

**ARTICLE XXV
ADDITIONAL MONITORING PROVISIONS**

25.1. Access to Documentation. The Award will be monitored for compliance in accordance with the terms and conditions of this Agreement, together with appropriate programmatic rules, regulations, and/or guidelines that the Grantor promulgates or implements. The Grantee must permit any agent authorized by the Grantor, upon presentation of credentials, in accordance with all methods available by law, full access to and the right to examine any document, papers and records either in hard copy or electronic format, of the Grantee involving transactions relating to this Award.

25.2. Cooperation with Audits and Inquiries, Confidentiality. Pursuant to ARTICLE IX, above, the Grantee is obligated to cooperate with the Grantor and other legal authorities in any audit or inquiry related to the Award. The Grantor or any other governmental authority conducting an audit or inquiry may require the Grantee to keep confidential any audit or inquiry and to limit internal disclosure of the audit or inquiry to those Grantee personnel who are necessary to support the Grantee's response to the audit or inquiry. This confidentiality requirement does not limit Grantee's right to discuss an audit or inquiry with its legal counsel. If a third party seeks to require the Grantee, pursuant to any law, regulation, or legal process, to disclose an audit or inquiry that has been deemed confidential by the Grantor or other governmental authority, the Grantee must promptly notify the entity that is conducting the audit or inquiry of such effort so that the entity that is conducting the audit or inquiry may seek a protective order, take other appropriate action, or waive compliance by the Grantee with the confidentiality requirement.

**ARTICLE XXVI
ADDITIONAL INTEREST PROVISIONS**

26.1. Interest Earned on Grant Funds. Interest earned on Grant Funds in an amount up to \$500 per year may be retained by the Grantee for administrative expenses unless otherwise provided in **PART THREE**. Any additional interest earned on Grant Funds above \$500 per year must be returned to the Grantor pursuant to Paragraphs 4.3 and 29.2 herein, or as otherwise instructed by the Grant Manager or as set forth in **PART THREE**. All interest earned must be expended prior to Grant Funds. Any unspent Grant Funds or earned interest unspent must be returned as Grant Funds to the Grantor as described in Paragraphs 4.3 and 29.2 herein. All interest earned on Grant Funds must be accounted for and reported to the Grantor as provided in ARTICLE X herein. If applicable, the Grantor will remit interest earned and returned by Grantee to the U.S. Department of Health and Human Services Payment Management System through the process set forth at 2 CFR 200.305(b)(9), or as otherwise directed by the federal awarding agency. The provisions of this Paragraph are inapplicable to the extent any statute, rule or program requirement provides for different treatment of interest income. Any provision that deviates from this paragraph is set forth in **PART THREE**.

ARTICLE XXVII ADDITIONAL BUDGET PROVISIONS

27.1. Restrictions on Line Item Transfers. Unless set forth otherwise in **PART THREE** herein, Budget line item transfers within the guidelines set forth in paragraph 6.2 herein, which would not ordinarily require approval from Grantor, but vary more than ten percent (10%) of the current approved Budget line item amount, are considered changes in the project scope and require Prior Approval from Grantor pursuant to 44 Ill. Admin. Code 7000.370(b).

ARTICLE XXVIII ADDITIONAL REPRESENTATIONS AND WARRANTIES

28.1. Grantee Representations and Warranties. In connection with the execution and delivery of this Agreement, the Grantee makes the following representations and warranties to Grantor:

- (a) That it has no public or private interest, direct or indirect, and will not acquire, directly or indirectly any such interest which does or may conflict in any manner with the performance of the Grantee's services and obligations under this Agreement;
- (b) That no member of any governing body or any officer, agent or employee of the State, has a personal financial or economic interest directly in this Agreement, or any compensation to be paid hereunder except as may be permitted by applicable statute, regulation or ordinance;
- (c) That there is no action, suit or proceeding at law or in equity pending, nor to the best of Grantee's knowledge, threatened, against or affecting the Grantee, before any court or before any governmental or administrative agency, which will have a material adverse effect on the performance required by this Agreement;
- (d) That to the best of the Grantee's knowledge and belief, the Grantee, its principals and key project personnel:
 - (i) Are not presently declared ineligible or voluntarily excluded from contracting with any federal or State department or agency;
 - (ii) Have not, within a three (3)-year period preceding this Agreement, been convicted of any felony; been convicted of a criminal offense in connection with obtaining, attempting to obtain, or performing a public (federal, state, or local) transaction or contract under a public transaction; had a civil judgment rendered against them for commission of fraud; been found in violation of federal or state antitrust statutes; or been convicted of embezzlement, theft, larceny, forgery, bribery, falsification or destruction of records, making a false statement, or receiving stolen property;

(iii) Are not presently indicted for, or otherwise criminally or civilly charged, by a government entity (federal, state or local) with commission of any of the offenses enumerated in subparagraph (ii) of this certification; and

(iv) Have not had, within a three (3)-year period preceding this Agreement, any judgment rendered in an administrative, civil or criminal matter against the Grantee, or any entity associated with its principals or key personnel, related to a grant issued by any federal or state agency or a local government.

Any request for an exception to the provisions of this subparagraph (d) must be made in writing, listing the name of the individual, home address, type of conviction and date of conviction; and

(e) Grantee certifies that it is not currently operating under, or subject to, any cease and desist order, or subject to any informal or formal regulatory action, and, to the best of Grantee's knowledge, that it is not currently the subject of any investigation by any state or federal regulatory, law enforcement or legal authority. Should it become the subject of an investigation by any state or federal regulatory, law enforcement or legal authority, Grantee shall promptly notify Grantor of any such investigation. Grantee acknowledges that should it later be subject to a cease and desist order, Memorandum of Understanding, or found in violation pursuant to any regulatory action or any court action or proceeding before any administrative agency, that Grantor is authorized to declare Grantee out of compliance with this Agreement and suspend or terminate the Agreement pursuant to ARTICLE XIII herein and any applicable rules.

ARTICLE XXIX

ADDITIONAL TERMINATION, SUSPENSION, BILLING SCHEDULE AND NON-COMPLIANCE PROVISIONS

29.1. Remedies for Non-Compliance. If Grantor suspends or terminates this Agreement pursuant to ARTICLE XIII herein, Grantor may also elect any additional remedy allowed by law, including, but not limited to, one or more of the following remedies:

(a) Direct the Grantee to refund some or all of the Grant Funds disbursed to it under this Agreement; and

(b) Direct the Grantee to remit an amount equivalent to the "Net Salvage Value" of all equipment or materials purchased with Grant Funds provided under this Agreement. For purposes of this Agreement, "Net Salvage Value" is defined as the amount realized, or that the Parties agree is likely to be realized from, the sale of equipment or materials purchased with Grant Funds provided under this Agreement at its current fair market value, less selling expenses.

29.2. Grant Refunds. In accordance with the Illinois Grant Funds Recovery Act, 30 ILCS 705/1 *et seq.*, the Grantee must, within forty-five (45) days of the effective date of a termination of this Agreement, refund to Grantor, any balance of Grant Funds not spent or not obligated as of that date.

29.3. Grant Funds Recovery Procedures. In the event that Grantor seeks to recover from Grantee Funds received pursuant to this Award that: (i) Grantee cannot demonstrate were properly spent, or (ii) have not been expended or legally obligated by the time of expiration or termination of this Award, the Parties agree to follow the procedures set forth in the Illinois Grant Funds Recovery Act, 30 ILCS 705/1 *et seq.* (GFRA), for the recovery of Grant Funds, including the informal and formal hearing requirements. All remedies available in Section 6 of the GFRA will apply to these proceedings. The Parties agree that Grantor's Administrative Hearing Rules (56 Ill. Admin. Code Part 2605) and/or any other applicable hearing rules shall govern these proceedings.

29.4. Grantee Responsibility. Grantee will be held responsible for the expenditure of all Grant Funds received through this Award, whether expended by Grantee or a subrecipient or contractor of Grantee. Grantor may

seek any remedies against Grantee permitted pursuant to this Agreement and 2 CFR 200.339 for the action of a subrecipient or contractor of Grantee that is not in compliance with the applicable statutes, regulations or the terms and conditions of this Award.

29.5. Billing Schedule. In accordance with paragraph 4.8, herein Grantee must submit all payment requests to Grantor within thirty (30) days of the end of the quarter, unless another billing schedule is specified in **PART THREE** or Paragraph 2.3. Failure to submit such payment request timely will render the amounts billed an unallowable cost which Grantor cannot reimburse. In the event that Grantee is unable, for good cause, to submit its payment request timely, Grantee must timely notify Grantor and may request an extension of time to submit the payment request. Grantor's approval of Grantee's request for an extension cannot be unreasonably withheld. The payment requirements of this Paragraph supersede those set forth in Paragraph 4.8.

ARTICLE XXX ADDITIONAL MODIFICATION PROVISIONS

30.1. Modifications by Operation of Law. This Agreement is subject to such modifications as the Grantor determines, in its sole discretion, may be required by changes in federal or State law or regulations applicable to this Agreement. Grantor will initiate such modifications, and Grantee will be required to agree to the modification in writing as a condition of continuing the Award. Any such required modification will be incorporated into and become part of this Agreement as if fully set forth herein. The Grantor will timely notify the Grantee of any pending implementation of or proposed amendment to any laws or regulations of which it has notice.

30.2. Discretionary Modifications. If either the Grantor or the Grantee wishes to modify the terms of this Agreement other than as set forth in ARTICLES V and VI and Paragraphs 30.1 and 30.3, written notice of the proposed modification must be given to the other Party. Modifications will only take effect when agreed to in writing by both the Grantor and the Grantee. However, if the Grantor notifies the Grantee in writing of a proposed modification, and the Grantee fails to respond to that notification, in writing, within thirty (30) days, the Grantor may commence a process to suspend or terminate this Award. In making an objection to the proposed modification, the Grantee must specify the reasons for the objection and the Grantor will consider those objections when evaluating whether to follow through with the proposed modification. The Grantor's notice to the Grantee must contain the Grantee name, Agreement number, Amendment number and purpose of the revision. If the Grantee seeks any modification to the Agreement, the Grantee must submit a detailed narrative explaining why the Project cannot be completed in accordance with the terms of the Agreement and how the requested modification will ensure completion of the Grant Activities, Deliverables, Milestones and/or Performance Measures (**Exhibits A, B and D**).

30.3. Unilateral Modifications. The Parties agree that Grantor may, in its sole discretion, unilaterally modify this Agreement without prior approval of the Grantee when the modification is initiated by Grantor for the sole purpose of increasing the Grantee's funding allocation as additional funds become available for the Award during the program year covered by the Term of this Agreement.

30.4. Management Waiver. The Parties agree that the Grantor may issue a waiver of specific requirements of this Agreement after the term of the Agreement has expired. These waivers are limited to non-material changes to specific provisions that the Grantor determines are necessary to place the Grantee in administrative compliance with the requirements of this Agreement. A management waiver issued after the Term of the Agreement has expired will supersede the original requirements of this Agreement that would normally require a modification of this Agreement to be executed. The Grantor will make no modifications of this Agreement not agreed to prior to the expiration of the Agreement beyond what is specifically set forth in this Paragraph.

30.5. Term Extensions. The Grantee acknowledges that all Grant Funds must be expended or legally obligated, and all Grant Activities, Deliverables, Milestones and Performance Measures (**Exhibits A, B and D**) must be completed during the Term of the Agreement. Extensions of the Term will be granted only for good cause, subject to the Grantor's discretion. Pursuant to the Grant Funds Recovery Act (30 ILCS 705/1 *et seq.*), no Award may be

extended in total beyond a two (2)-year period unless the Grant Funds are expended or legally obligated during that initial two-year period, or unless Grant Funds are disbursed for reimbursement of costs previously incurred by the Grantee. If Grantee requires an extension of the Award Term, Grantee should submit a written request to the Grant Manager at least sixty (60) days prior to the end of the Award Term or extended Award Term, as applicable, stating the reason for the extension. If Grantee provides reasonable extenuating circumstances, Grantee may request an extension of the Award Term with less than sixty (60) days remaining.

**ARTICLE XXXI
ADDITIONAL CONFLICT OF INTEREST PROVISIONS**

31.1. Bonus or Commission Prohibited. The Grantee shall not pay any bonus or commission for the purpose of obtaining the Grant Funds awarded under this Agreement.

31.2. Hiring State Employees Prohibited. No State officer or employee may be hired to perform services under this Agreement on behalf of the Grantee, or be paid with Grant Funds derived directly or indirectly through this Award without the written approval of the Grantor unless Grantee is a State agency.

**ARTICLE XXXII
ADDITIONAL EQUIPMENT OR PROPERTY PROVISIONS**

32.1. Equipment Management. The Grantee is responsible for replacing or repairing equipment and materials purchased with Grant Funds that are lost, stolen, damaged, or destroyed. Any loss, damage or theft of equipment and materials must be investigated and fully documented, and immediately reported to the Grantor and, where appropriate, the appropriate law enforcement authorities.

32.2. Purchase of Real Property. If permitted by the Award Budget and scope of activities provided in this Agreement, a Grantee may use the Grant Funds during the Award Term for the costs associated with the purchase of real property (as defined by 2 CFR 200.1) either through the use of reimbursement or advanced funds as permitted in Paragraph 2.3 of this Agreement for the following purposes and consistent with the Grantor's bondability guidelines and 2 CFR 200:

- (a) Cash payment of the entirety or a portion of the real property acquisition;
- (b) Cash Payment of a down payment for the acquisition;
- (c) Standard and commercially reasonable costs required to be paid at the acquisition closing (*i.e.*, closing costs); or
- (d) Payments to reduce the debt incurred by Grantee to purchase the real property.

32.3. Bonding Requirements. If Grant Funds through this Award are used for construction or facility improvement projects that exceed the Simplified Acquisition Threshold, the Grantee must comply with the minimum bonding requirements listed in 2 CFR 200.326(a) – (c). Grantor will not accept the Grantee's own bonding policy and requirements.

32.4. Lien Requirements. Grantor may direct Grantee in writing to record a lien or notice of State or federal interest on the property purchased or improved with Grant Funds. 2 CFR 200.316. If Grantor makes this direction and the Grantee does not comply, the Grantor may: (a) record the lien or notice of State or federal interest and reduce the amount of the Grant Funds by the cost of recording the lien or notice of State or federal interest, or (b) suspend this Award until Grantee complies with Grantor's direction.

**ARTICLE XXXIII
APPLICABLE STATUTES**

To the extent applicable, Grantor and Grantee shall comply with the following:

33.1. Grantee Responsibility. Grantee is responsible for ensuring compliance with all applicable laws, rules and regulations, including, but not limited to those specifically referenced herein. Except where expressly required by applicable laws and regulations, the Grantor shall not be responsible for monitoring Grantee's compliance.

33.2. Land Trust Beneficial Interest Disclosure Act (765 ILCS 405/2.1). No Grant Funds will be paid to any trustee of a land trust, or any beneficiary or beneficiaries of a land trust, for any purpose relating to the land, which is the subject of such trust, any interest in such land, improvements to such land or use of such land unless an affidavit is first filed with the Grantor identifying each beneficiary of the land trust by name and address and defining such interest therein. This affidavit must be filed with the Illinois Office of the Comptroller as an attachment to this Agreement.

33.3. Historic Preservation Act (20 ILCS 3420/1 et seq.). The Grantee will not expend Grant Funds under this Agreement which result in the destruction, alteration, renovation, transfer or sale, or utilization of a historic property, structure or structures, or in the introduction of visual, audible or atmospheric elements to a historic property, structure or structures, which will result in the change in the character or use of any historic property, except as approved by the Illinois Department of Natural Resources, Historic Preservation Division. The Grantee must not expend Grant Funds under this Agreement for any project, activity, or program that can result in changes in the character or use of historic property, if any historic property is located in the area of potential effects without the approval of the Illinois Department of Natural Resources, Historic Preservation Division. 20 ILCS 3420/3(f).

33.4. Victims' Economic Security and Safety Act (820 ILCS 180 et seq.). If the Grantee has one (1) or more employees, it may not discharge or discriminate against an employee who is a victim of domestic or sexual violence, or who has a family or household member who is a victim of domestic or sexual violence, for taking up to the allowable amount of leave from work to address the domestic violence, pursuant to the Victims' Economic Security and Safety Act. 820 ILCS 180/20(a)(2). The Grantee is not required to provide paid leave under the Victims' Economic Security and Safety Act, but may not suspend group health plan benefits during the leave period. Any failure on behalf of the Grantee to comply with all applicable provisions of the Victims' Economic Security and Safety Act, or applicable rules and regulations promulgated thereunder, may result in a determination that the Grantee is ineligible for future contracts or subcontracts with the State of Illinois or any of its political subdivisions or municipal corporations, and this Agreement may be cancelled or voided in whole or in part, and such other sanctions or penalties may be imposed or remedies invoked, as provided by statute or regulation.

33.5. Equal Pay Act of 2003 (820 ILCS 112 et seq.). If the Grantee has one (1) or more employees, it is prohibited by the Equal Pay Act of 2003 from: (a) discriminating between employees by paying unequal wages on the basis of sex for doing the same or substantially similar work; (b) discriminating between employees by paying wages to an African-American employee at a rate less than the rate at which the Grantee pays wages to another employee who is not African-American for the same or substantially similar work; (c) remedying violations of the Equal Pay Act of 2003 by reducing the wages of other employees or discriminating against any employee exercising their rights under the Equal Pay Act of 2003; and (d) screening job applicants based on their current or prior wages or salary histories, or requesting or requiring a wage or salary history from an individual as a condition of employment or consideration for employment. Any failure on behalf of the Grantee to comply with all applicable provisions of the Equal Pay Act of 2003, or applicable rules and regulations promulgated thereunder, may result in a determination that the Grantee is ineligible for future contracts or subcontracts with the State of Illinois or any of its political subdivisions or municipal corporations, and this Agreement may be cancelled or voided in whole or in part, and such other sanctions or penalties may be imposed or remedies invoked, as provided by statute or regulation.

33.6. Steel Products Procurement Act (30 ILCS 565/1 et seq.). The Grantee, if applicable, hereby certifies that any steel products used or supplied in accordance with this Award for a public works project shall be

manufactured or produced in the United States per the requirements of the Steel Products Procurement Act (30 ILCS 565/1 *et seq.*).

33.7. Business Enterprise for Minorities, Women, and Persons with Disabilities Act and Illinois Human Rights Act (30 ILCS 575/0.01; 775 ILCS 5/2-105). The Grantee acknowledges and hereby certifies compliance with the provisions of the Business Enterprise for Minorities, Women, and Persons with Disabilities Act, and the equal employment practices of Section 2-105 of the Illinois Human Rights Act for the provision of services which are directly related to the Award activities to be performed under this Agreement.

33.8. Identity Protection Act (5 ILCS 179/1 *et seq.*) and Personal Information Protection Act (815 ILCS 530/1 *et seq.*). The Grantor is committed to protecting the privacy of its vendors, grantees and beneficiaries of programs and services. At times, the Grantor will request social security numbers or other personal identifying information. Federal and state laws, rules and regulations require the collection of this information for certain purposes relating to employment and/or payments for goods and services, including, but not limited to, Awards. The Grantor also collects confidential information for oversight and monitoring purposes.

Furnishing personal identity information, such as a social security number, is voluntary; however, failure to provide required personal identity information may prevent an individual or organization from using the services/benefits provided by the Grantor as a result of state or federal laws, rules and regulations.

To the extent the Grantee collects or maintains protected personal information as part of carrying out the Award activities, the Grantee must maintain the confidentiality of the protected personal information in accordance with applicable law and as set forth below.

(a) **Personal Information Defined.** As used herein, "Personal Information" shall have the definition set forth in the Personal Information Protection Act, 815 ILCS 530/5 ("PIPA").

(b) **Protection of Personal Information.** The Grantee must use at least reasonable care to protect the confidentiality of Personal Information that is collected or maintained as part of the Award activities and (i) not use any Personal Information for any purpose outside the scope of the Award activities and (ii) except as otherwise authorized by the Grantor in writing, limit access to Personal Information to those of its employees, contractors, and agents who need such access for purposes consistent with the Award Activities. If Grantee provides any contractor or agent with access to Personal Information, it must require the contractor or agent to comply with the provisions of this Paragraph.

(c) **Security Assurances.** Grantee represents and warrants that it has established and will maintain safeguards against the loss and unauthorized access, acquisition, destruction, use, modification, or disclosure of Personal Information and shall otherwise maintain the integrity of Personal Information in its possession in accordance with any federal or state law privacy requirements, including PIPA. These safeguards must be reasonably designed to (i) ensure the security and confidentiality of the Personal Information, (ii) protect against any anticipated threats or hazards to the security or integrity of Personal Information, and (iii) protect against unauthorized access to or use of Personal Information. Additionally, Grantee will have in place policies, which provide for the secure disposal of documents and information which contain Personal Information, including but not limited to shredding documents and establishing internal controls over the authorized access to such information. 815 ILCS 530/40.

(d) **Breach Response.** In the event of any unauthorized access to, unauthorized disclosure of, loss of, damage to or inability to account for any Personal Information (a "Breach"), Grantee agrees that it will promptly, at its own expense: (i) report such Breach to the Grantor by telephone with immediate written confirmation sent by e-mail, describing in detail any accessed materials and identifying any individual(s) who may have been involved in such Breach; (ii) take all actions necessary or reasonably requested by the Grantor to stop, limit or minimize the Breach; (iii) restore and/or retrieve, as applicable, and return all Personal Information that was lost, damaged, accessed, copied or removed; (iv) cooperate in

all reasonable respects to minimize the damage resulting from such Breach; (v) provide any notice to Illinois residents as required by 815 ILCS 530/10, 815 ILCS 530/12 or applicable federal law, in consultation with the Grantor; and (vi) cooperate in the preparation of any report related to the Breach that the Grantor may need to present to any governmental body.

(e) **Injunctive Relief.** Grantee acknowledges that, in the event of a breach of this Paragraph, Grantor will likely suffer irreparable damage that cannot be fully remedied by monetary damages. Accordingly, in addition to any remedy which the Grantor may possess pursuant to applicable law, the Grantor retains the right to seek and obtain injunctive relief against any such breach in any Illinois court of competent jurisdiction.

(f) **Compelled Access or Disclosure.** The Grantee may disclose Personal Information if it is compelled by law, regulation, or legal process to do so, provided the Grantee gives the Grantor at least ten (10) days' prior notice of such compelled access or disclosure (to the extent legally permitted) and reasonable assistance if the Grantor wishes to contest the access or disclosure.

ARTICLE XXXIV ADDITIONAL MISCELLANEOUS PROVISIONS

34.1. **Workers' Compensation Insurance, Social Security, Retirement and Health Insurance Benefits, and Taxes.** The Grantee must provide Workers' Compensation insurance where the same is required and accepts full responsibility for the payment of unemployment insurance, premiums for Workers' Compensation, Social Security and retirement and health insurance benefits, as well as all income tax deduction and any other taxes or payroll deductions required by law for its employees who are performing services specified by this Agreement.

34.2. **Required Notice.** Grantee agrees to give prompt notice to the Grantor of any event that may materially affect the performance required under this Agreement. Any notice or final decision by Grantor relating to (a) a Termination or Suspension (ARTICLE XIII), (b) Modifications, Management Waivers or Term Extensions (ARTICLE XXX) or (c) Assignments (Paragraph 22.2) must be executed by the Director of the Grantor or her or his authorized designee.

ARTICLE XXXV ADDITIONAL REQUIRED CERTIFICATIONS

The Grantee makes the following certifications as a condition of this Agreement. These certifications are required by State statute and are in addition to any certifications required by any federal funding source as set forth in this Agreement. Grantee's execution of this Agreement shall serve as its attestation that the certifications made herein are true and correct.

35.1. **Sexual Harassment.** The Grantee certifies that it has written sexual harassment policies that must include, at a minimum, the following information: (i) the illegality of sexual harassment; (ii) the definition of sexual harassment under State law; (iii) a description of sexual harassment, utilizing examples; (iv) the Grantee's internal complaint process including penalties; (v) the legal recourse, investigative and complaint process available through the Department of Human Rights and the Human Rights Commission; (vi) directions on how to contact the Department of Human Rights and the Human Rights Commission; and (vii) protection against retaliation as provided by Sections 6-101 and 6-101.5 of the Illinois Human Rights Act. 775 ILCS 5/2-105(A)(4). A copy of the policies must be provided to the Grantor upon request.

35.2. **Federal, State and Local Laws; Tax Liabilities; State Agency Delinquencies.** The Grantee is required to comply with all federal, state and local laws, including but not limited to the filing of any and all applicable tax returns. If Grantee is delinquent in filing and/or paying any federal, state and/or local taxes, the Grantor will disburse

Grant Funds only if the Grantee enters into an installment payment agreement with the applicable tax authority and remains in good standing with that authority. Grantee is required to tender a copy of all relevant installment payment agreements to the Grantor. In no event may Grantee utilize Grant Funds to discharge outstanding tax liabilities or other debts owed to any governmental unit. **The execution of this Agreement by the Grantee is its certification that: (i) it is current as to the filing and payment of any federal, state and/or local taxes applicable to Grantee; and (ii) it is not delinquent in its payment of moneys owed to any federal, state, or local unit of government.**

35.3. Lien Waivers. If applicable, the Grantee must monitor construction to assure that necessary contractors' affidavits and waivers of mechanics liens are obtained prior to release of Grant Funds to contractors and subcontractors.

35.4. Grant for the Construction of Fixed Works. Grantee certifies that all Projects for the construction of fixed works which are financed in whole or in part with funds provided by this Agreement will be subject to the Prevailing Wage Act (820 ILCS 130/0.01 *et seq.*) unless the provisions of that Act exempt its application. In the construction of the Projects, Grantee must comply with the requirements of the Prevailing Wage Act including, but not limited to: (a) paying the prevailing rate of wages required by the Illinois Department of Labor, or a court on review, to all laborers, workers and mechanics performing work with Grant Funds provided through this Agreement, (b) inserting into all contracts for such construction a stipulation to the effect that not less than the prevailing rate of wages as applicable to the Project must be paid to all laborers, workers, and mechanics performing work under this Award; and (c) requiring all bonds of contractors to include a provision as will guarantee the faithful performance of the prevailing wage clause as provided by contract.

THE REMAINDER OF THIS PAGE IS INTENTIONALLY LEFT BLANK.

PART THREE – PROJECT-SPECIFIC TERMS

In addition to the uniform requirements in **PART ONE** and Grantor-Specific Terms in **PART TWO**, Grantor has the following additional requirements for this Project:

**ARTICLE XXXVI
REPORT DELIVERABLE SCHEDULE**

36.1. External Audit Reports. External Audit Reports may be required. Refer to ARTICLE XII of this Agreement to determine whether you are required to submit an External Audit Report and the applicable due date.

36.2. Annual Financial Reports. Annual Financial Reports may be required. Refer to Paragraph 12.2 of this Agreement to determine whether you are required to submit Annual Financial Reports.

36.3. Required Periodic Reports. Below is the required periodic reporting schedule for this Award.

December 2023

- Monthly Periodic Financial Report (12/15/2023) - Covering Period of 10/01/2023 - 11/30/2023; Send To: Grant Manager
- Monthly Periodic Performance Report (12/15/2023) - Covering Period of 10/01/2023 - 11/30/2023; Send To: Grant Manager

January 2024

- Monthly Periodic Financial Report (01/15/2024) - Covering Period of 12/01/2023 - 12/31/2023; Send To: Grant Manager
- Monthly Periodic Performance Report (01/15/2024) - Covering Period of 12/01/2023 - 12/31/2023; Send To: Grant Manager

February 2024

- Monthly Periodic Financial Report (02/15/2024) - Covering Period of 01/01/2024 - 01/31/2024; Send To: Grant Manager
- Monthly Periodic Performance Report (02/15/2024) - Covering Period of 01/01/2024 - 01/31/2024; Send To: Grant Manager

March 2024

- Monthly Periodic Financial Report (03/15/2024) - Covering Period of 02/01/2024 - 02/29/2024; Send To: Grant Manager
- Monthly Periodic Performance Report (03/15/2024) - Covering Period of 02/01/2024 - 02/29/2024; Send To: Grant Manager

April 2024

- Monthly Periodic Financial Report (04/15/2024) - Covering Period of 03/01/2024 - 03/31/2024; Send To: Grant Manager
- Monthly Periodic Performance Report (04/15/2024) - Covering Period of 03/01/2024 - 03/31/2024; Send To: Grant Manager

May 2024

- Monthly Periodic Financial Report (05/15/2024) - Covering Period of 04/01/2024 - 04/30/2024; Send To: Grant Manager
- Monthly Periodic Performance Report (05/15/2024) - Covering Period of 04/01/2024 - 04/30/2024; Send To: Grant Manager

June 2024

- Monthly Periodic Financial Report (06/17/2024) - Covering Period of 05/01/2024 - 05/31/2024; Send To: Grant Manager
- Monthly Periodic Performance Report (06/17/2024) - Covering Period of 05/01/2024 - 05/31/2024; Send To: Grant Manager

July 2024

- Monthly Periodic Financial Report (07/15/2024) - Covering Period of 06/01/2024 - 06/30/2024; Send To: Grant Manager
- Monthly Periodic Performance Report (07/15/2024) - Covering Period of 06/01/2024 - 06/30/2024; Send To: Grant Manager

August 2024

- Monthly Periodic Financial Report (08/15/2024) - Covering Period of 07/01/2024 - 07/31/2024; Send To: Grant Manager
- Monthly Periodic Performance Report (08/15/2024) - Covering Period of 07/01/2024 - 07/31/2024; Send To: Grant Manager

September 2024

- Monthly Periodic Financial Report (09/16/2024) - Covering Period of 08/01/2024 - 08/31/2024; Send To: Grant Manager
- Monthly Periodic Performance Report (09/16/2024) - Covering Period of 08/01/2024 - 08/31/2024; Send To: Grant Manager

October 2024

- Monthly Periodic Financial Report (10/15/2024) - Covering Period of 09/01/2024 - 09/30/2024; Send To: Grant Manager
- Monthly Periodic Performance Report (10/15/2024) - Covering Period of 09/01/2024 - 09/30/2024; Send To: Grant Manager

November 2024

- Monthly Periodic Financial Report (11/15/2024) - Covering Period of 10/01/2024 - 10/31/2024; Send To: Grant Manager
- Monthly Periodic Performance Report (11/15/2024) - Covering Period of 10/01/2024 - 10/31/2024; Send To: Grant Manager

December 2024

- Monthly Periodic Financial Report (12/16/2024) - Covering Period of 11/01/2024 - 11/30/2024; Send To: Grant Manager
- Monthly Periodic Performance Report (12/16/2024) - Covering Period of 11/01/2024 - 11/30/2024; Send To: Grant Manager

January 2025

- Monthly Periodic Financial Report (01/15/2025) - Covering Period of 12/01/2024 - 12/31/2024; Send To: Grant Manager
- Monthly Periodic Performance Report (01/15/2025) - Covering Period of 12/01/2024 - 12/31/2024; Send To: Grant Manager

February 2025

- Monthly Periodic Financial Report (02/17/2025) - Covering Period of 01/01/2025 - 01/31/2025; Send To: Grant Manager
- Monthly Periodic Performance Report (02/17/2025) - Covering Period of 01/01/2025 - 01/31/2025; Send To: Grant Manager

March 2025

- Monthly Periodic Financial Report (03/17/2025) - Covering Period of 02/01/2025 - 02/28/2025; Send To: Grant Manager
- Monthly Periodic Performance Report (03/17/2025) - Covering Period of 02/01/2025 - 02/28/2025; Send To: Grant Manager

April 2025

- Monthly Periodic Financial Report (04/15/2025) - Covering Period of 03/01/2025 - 03/31/2025; Send To: Grant Manager
- Monthly Periodic Performance Report (04/15/2025) - Covering Period of 03/01/2025 - 03/31/2025; Send To: Grant Manager

May 2025

- Monthly Periodic Financial Report (05/15/2025) - Covering Period of 04/01/2025 - 04/30/2025; Send To: Grant Manager
- Monthly Periodic Performance Report (05/15/2025) - Covering Period of 04/01/2025 - 04/30/2025; Send To: Grant Manager

June 2025

- Monthly Periodic Financial Report (06/16/2025) - Covering Period of 05/01/2025 - 05/31/2025; Send To: Grant Manager
- Monthly Periodic Performance Report (06/16/2025) - Covering Period of 05/01/2025 - 05/31/2025; Send To: Grant Manager

July 2025

- Monthly Periodic Financial Report (07/15/2025) - Covering Period of 06/01/2025 - 06/30/2025; Send To: Grant Manager
- Monthly Periodic Performance Report (07/15/2025) - Covering Period of 06/01/2025 - 06/30/2025; Send To: Grant Manager

August 2025

- Monthly Periodic Financial Report (08/15/2025) - Covering Period of 07/01/2025 - 07/31/2025; Send To: Grant Manager

- Monthly Periodic Performance Report (08/15/2025) - Covering Period of 07/01/2025 - 07/31/2025; Send To: Grant Manager

September 2025

- Monthly Periodic Financial Report (09/15/2025) - Covering Period of 08/01/2025 - 08/31/2025; Send To: Grant Manager
- Monthly Periodic Performance Report (09/15/2025) - Covering Period of 08/01/2025 - 08/31/2025; Send To: Grant Manager

October 2025

- Monthly Periodic Financial Report (10/15/2025) - Covering Period of 09/01/2025 - 09/30/2025; Send To: Grant Manager
- Monthly Periodic Performance Report (10/15/2025) - Covering Period of 09/01/2025 - 09/30/2025; Send To: Grant Manager

November 2025

- End of grant Closeout Financial Report (11/14/2025) - Covering Period of 10/01/2023 - 09/30/2025; Send To: Grant Manager
- End of grant Closeout Performance Report (11/14/2025) - Covering Period of 10/01/2023 - 09/30/2025; Send To: Grant Manager

36.4. Changes to Reporting Schedule. Changes to the schedules for periodic reporting, the external audit reports and the annual financial reports do not require a formal modification to this Agreement pursuant to Paragraph 22.4 and ARTICLE XXX, and may be changed unilaterally by the Grantor if necessitated by a change in the project schedule or at the discretion of the Grantor. The Grantee may not modify the reporting deliverable schedules in ARTICLES X, XI, XII and XXXVI unilaterally, and must obtain prior written approval from Grantor or the Grant Accountability and Transparency Unit of the Governor's Office of Management and Budget, if applicable, to change any reporting deadlines.

**ARTICLE XXXVII
GRANT-SPECIFIC TERMS/CONDITIONS**

37.1 Coronavirus State and Local Fiscal Recovery Funds Compliance. The Grant Funds awarded pursuant to this Agreement are a subaward from the State's allocation from the Coronavirus State Fiscal Recovery Fund ("SLFRF") established by Section 602 of the Social Security Act, 42 USC 802. Grantee is required to comply with, and is subject to, all requirements of the SLFRF, the final rule implementing the SLFRF, effective April 1, 2022 (the "final rule"), (87 Fed. Reg. 4338, Jan. 27, 2022) and all other related rules and guidance issued by Grantor and the U.S. Department of the Treasury ("Treasury"), including, but not limited to the following:

(a) Interest on Grant Funds. The Grant Funds awarded pursuant to this Agreement are not subject to the requirements of the Cash Management Improvement Act and Treasury's implementing regulations at 31 CFR Part 205 or 2 CFR 200.305(b)(8)-9. Thus, Grantee is exempt from the provisions in Paragraph 4.7 of this Agreement. As such, Grantee can deposit Grant Funds in an interest-bearing account, does not need to remit interest to Grantor or to Treasury, and is not limited to using that interest for eligible uses under this Award.

(b) Recordkeeping Requirements.

(i) The SLFRF guidance issued by Treasury requires a longer records retention period than is required by paragraph 12.1 of this Agreement. Therefore, the Grantee is required to maintain, until December 31, 2031, adequate books, all financial records and supporting documents, statistical records, and all other records pertinent to this Award. If any litigation, claim or audit is started before the expiration of the retention period, the records must be retained until all litigation, claims or audit exceptions involving the records have been resolved and final action taken. Grantee is responsible for ensuring all contractors and subrecipients, if applicable, adhere to these records retention requirements.

(ii) Grantee agrees to provide or make available all records related to this Award to Grantor or to Treasury upon request, and to any authorized oversight body, including, but not limited to, the Government Accountability Office ("GAO"), Treasury's Office of Inspector General ("OIG"), and the Pandemic Relief Accountability Committee ("PRAC").

(c) Audits.

(i) Grantee may not use Grant Funds for costs for audits not performed in accordance with 2 CFR 200, Subpart F. Grantee also may be subject to audits as deemed necessary by authorized governmental entities, including Treasury, the GAO, the PRAC and the Treasury's OIG. Per Treasury Guidance, Grantee may be exempt from certain requirements in ARTICLE XV, as set forth below.

(ii) Notwithstanding the provisions in ARTICLE XV herein:

The financial statement audit thresholds and the requirement to submit a Consolidated Year-End Financial Report set forth in Article XV do not apply to this Award for all grantees. Further, if Grantee is a "for-profit" entity, the program-specific audit threshold and the requirement for Grantee to submit an annual audit to Grantor in ARTICLE XV, if applicable, also do not apply.

(d) Civil Rights Law Compliance. In addition to the other non-discrimination and Civil Rights law compliance required in this Agreement, Grantee also certifies it is in full compliance with the terms and provisions of all legal requirements of the Treasury relating to non-discrimination and non-discriminatory use of federal funds. These requirements include ensuring that Grantee does not deny benefits or services, or otherwise discriminate on the basis of race, color, national origin (including limited English proficiency), disability, age, or sex (including sexual orientation and gender identity), in accordance with the following authorities: Title VI of the Civil Rights Act of 1964 (42 USC 2000d-1 *et seq.*) and the Treasury's implementing regulations, 31 CFR Part 22; Section 504 of the Rehabilitation Act of 1973 (29 USC 794), Title IX of the Education Amendments of 1972 (20 USC 1681 *et seq.*) and the Treasury's implementing regulations, 31 CFR Part 28; and the Age Discrimination Act of 1975 (42 USC 6101 *et seq.*) and the Treasury's implementing regulations at 31 CFR Part 23.

(e) Reporting Requirements. In addition to the reporting requirements set forth in this Agreement, Grantee shall submit obligation and expenditure data and performance indicators and programmatic data as required by this section, the American Rescue Plan Act of 2021 and related federal guidance, in a format requested by Grantor. See Compliance and Reporting Guidance- State and Local Fiscal Recovery Funds, available at: <https://home.treasury.gov/system/files/136/SLFRF-Compliance-and-Reporting-Guidance.pdf>. To the extent possible, when applicable, Grantee should provide data disaggregated by race, ethnicity, gender, income, and other relevant factors as required by Grantor.

(i) Expenditure Category. For the purpose of the State of Illinois' required quarterly reports for its allocation from the SLFRF, this Award falls within the following expenditure category ("EC") 5.6.

(ii) Quarterly Reporting for Infrastructure Projects (EC 5.1 – 5.21) In addition to the expenditure reporting requirements, for all projects listed under the Water, Sewer and Broadband Infrastructure Expenditure Categories more detailed project-level information is required. See Compliance and Reporting Guidance- State and Local Fiscal Recovery Funds, at pp. 26-28, available at: <https://home.treasury.gov/system/files/136/SLFRF-Compliance-and-Reporting-Guidance.pdf>. For each project in these three categories Grantee is also required to report the following information in its quarterly reports:

1. All Infrastructure projects (EC 5.1 – 5.21):

- Projected/actual construction start date (month/year);
- Projected/actual initiation of operations date (month/year);
- Location (for broadband, geospatial location data of locations to be served); and
- **For projects over \$10 million (based on expected total cost):**

a. Grantee may provide a certification that, for the relevant project, all laborers and mechanics employed by contractors and subcontractors in the performance of such project are paid wages at rates not less than those prevailing, as determined by the U.S. Secretary of Labor in accordance with subchapter IV of chapter 31 of title 40, United States Code (commonly known as the “Davis-Bacon Act”), for the corresponding classes of laborers and mechanics employed on projects of a character similar to the contract work in the civil subdivision of the State in which the work is to be performed, or by the appropriate State entity pursuant to a corollary State prevailing-wage-in-construction law (commonly known as “baby Davis-Bacon Acts”). If such certification is not provided, Grantee must provide a project employment and local impact report detailing:

- The number of employees of contractors and subcontractors working on the project;
- The number of employees on the project hired directly and hired through a third party;
- The wages and benefits of workers on the project by classification; and
- Whether those wages are at rates less than those prevailing (as determined by the Davis-Bacon Act).

Grantee must maintain sufficient records to substantiate this information upon request.

b. Grantee may provide a certification that a project includes a project labor agreement, meaning a pre-hire collective bargaining agreement consistent with section 8(f) of the National Labor Relations Act (29 U.S.C. 158(f)). If Grantee does not provide such certification, Grantee must provide a project workforce continuity plan, detailing the following:

- How Grantee will ensure the project has ready access to a sufficient supply of appropriately skilled and unskilled labor to ensure high-quality construction throughout the life of the project, including a description of any required professional certifications and/or in-house training;
- How Grantee will minimize risks of labor disputes and disruptions that would jeopardize timeliness and cost-effectiveness of the project;
- How Grantee will provide a safe and healthy workplace that avoids delays and costs associated with workplace illnesses, injuries, and fatalities, including descriptions of safety training, certification, and/or licensure requirements for all relevant workers (e.g., OSHA 10, OSHA 30);

- Whether workers on the project will receive wages and benefits that will secure an appropriately skilled workforce in the context of the local or regional labor market; and
 - Whether the project has completed a project labor agreement.
- c. Whether the project prioritizes local hires.
- d. Whether the project has a Community Benefit Agreement, with a description of any such agreement.
- e. Provide a narrative description of workforce practices. Explain how the project uses strong labor standards to promote effective and efficient delivery of high-quality infrastructure projects while also supporting the economic recovery through strong employment opportunities for workers. For example, report whether any of the following practices are being utilized: project labor agreements, community benefits agreements, prevailing wage requirements, and local hiring.

2. Water and Sewer Projects (EC 5.1-5.18):

- National Pollutant Discharge Elimination System (NPDES) Permit Number (if applicable; for projects aligned with the Clean Water State Revolving Fund)
- Public Water System (PWS) ID number (if applicable; for projects aligned with the Drinking Water State Revolving Fund)
- Median Household Income of service area
- Lowest Quintile Income of the service area

(iii) Annual Reporting- Recovery Plan Performance Report. The State of Illinois is annually required to publish and submit to Treasury a Recovery Plan Performance Report. Grantor may provide data from Grantee's quarterly reports to the Governor's Office of Management and Budget or a designee for submission with the State's Recovery Plan Performance Report. Grantee may be required to provide additional data for annual reporting as requested by Grantor or as required by subsequent updates to Treasury guidance.

(f) Publications. Any publications produced with Grant Funds from this Award must display the following language: "This project [is being] [was] supported, in whole or in part, by federal award number SLT-3381 awarded to the State of Illinois by the U.S. Department of the Treasury."

(g) Protections for Whistleblowers. In accordance with 41 USC 4712, Grantee may not discharge, demote, or otherwise discriminate against an employee in reprisal for disclosing to any of the list of persons or entities provided below, information that the employee reasonably believes is evidence of gross mismanagement of a federal contract or grant, a gross waste of federal funds, an abuse of authority relating to a federal contract or grant, a substantial and specific danger to public health or safety, or a violation of law, rule, or regulation related to a federal contract (including the competition for or negotiation of a contract) or grant.

The list of persons and entities referenced in the paragraph above includes the following:

- A member of Congress or a representative of a committee of Congress;
- An Inspector General;
- The Government Accountability Office;
- A Treasury employee responsible for contract or grant oversight or management;
- An authorized official of the Department of Justice or other law enforcement agency;
- A court or grand jury; or

- A management official or other employee of Recipient, contractor, or subcontractor who has the responsibility to investigate, discover, or address misconduct.

Grantee shall inform its employees in writing of the rights and remedies provided under this paragraph, in the predominant native language of the workforce.

(h) Increasing Seat Belt Use in the United States. Pursuant to Executive Order 13043, 62 FR 19217 (Apr. 18, 1997), Grantee should encourage its contractors to adopt and enforce on-the-job seat belt policies and programs for their employees when operating company-owned, rented or personally owned vehicles.

(i) Reducing Text Messaging While Driving. Pursuant to Executive Order 13513, 74 FR 51225 (Oct. 6, 2009), Grantee should encourage its employees, subrecipients, and contractors to adopt and enforce policies that ban text messaging while driving, and Grantee should establish workplace safety policies to decrease accidents caused by distracted drivers.

(j) Disclosure to Treasury and Public Disclosure. Grantor is required to provide detailed obligation and expenditure information to Treasury for any contracts and grants awarded, loans issued, transfers made to other government entities, and direct payments made from SLFRF funds that are greater than \$50,000. Grantee acknowledges that identifying and demographic information (e.g. DUNS/UEI/FEIN number and location); the award date, type, amount and description; award payment method; and any other information contained within this Agreement may be subject to disclosure to Treasury by Grantor, the Governor's Office of Management and Budget, and/or their designees. Grantor cannot guarantee the information provided to Treasury will remain confidential. Subject to federal statutes governing confidentiality of personal identification information (e.g. 42 USC 405), Treasury will make data submitted by Grantor and other State entities publicly available. See Project and Expenditure Report User Guide, <https://home.treasury.gov/system/files/136/Project-and-Expenditure-Report-User-Guide.pdf>.

37.2 Use of Real Property. Grantee shall use any real property acquired, constructed or improved with Grant Funds pursuant to this Agreement to provide the programs and services specified herein for at least the Award Term stated in Paragraph 2.1. Grantee shall comply with the real property use and disposition requirements set forth in 2 CFR 200.311.

37.3 Projects Requiring External Sign-offs.

- (1) Pursuant to applicable statute(s), this Award requires sign-off by the following State agency(ies). **The status of the sign-off is indicated as of the date the Award is sent to the Grantee for execution:**

AGENCY	SIGN-OFF RECEIVED	SIGN-OFF OUTSTANDING
<input checked="" type="checkbox"/> Illinois State Historic Preservation Office	<input type="checkbox"/>	<input checked="" type="checkbox"/>
<input type="checkbox"/> Illinois Dept. of Agriculture	<input type="checkbox"/>	<input type="checkbox"/>
<input checked="" type="checkbox"/> Illinois Dept. of Natural Resources	<input type="checkbox"/>	<input checked="" type="checkbox"/>
<input type="checkbox"/> Illinois Environmental Protection Agency	<input type="checkbox"/>	<input type="checkbox"/>
<input type="checkbox"/> NONE APPLICABLE		

While **any** external sign-off is outstanding, the provisions of Item (3), immediately below apply with respect to the disbursement of funds under this Award.

NOTE: The fact that a sign-off has been received in no way relieves the Grantee of its obligation to comply with any conditions or requirements conveyed by the applicable agency(ies) in conjunction with the issuance of the sign-off for the project funded under this Agreement.

- (2) For projects subject to review by the Illinois Environmental Protection Agency (IEPA), the Grantee must, prior to construction, obtain a construction permit or "authorization to construct" from the IEPA pursuant to the provisions of the Environmental Protection Act, 415 ILCS 5/1 *et seq.*

(3) **External Sign-Off Provisions:**

- a.) The Project described in Exhibit A and funded under this Agreement is subject to review by the external agency(ies) indicated in Item (1) immediately above. Grantee must comply with requirements established by said agency(ies) relative to their respective reviews. **Any requirements communicated to the Grantor shall be incorporated into this Agreement as follows: as an attachment to this Agreement (immediately following PART THREE) at the time of the Agreement execution.** The Grantee is contractually obligated to comply with such requirements.
- b.) Grantee is responsible for coordinating directly with the applicable external agency(ies) relative to said reviews. Except as specifically provided below, the Grantor's obligation to disburse funds under this Agreement is contingent upon notification by the applicable agency(ies) that all requirements applicable to the project described in this Agreement have been satisfied. Upon receipt of said notification, disbursement of the Grant Funds shall be authorized in accordance with the provisions of Paragraph 2.3 herein.
- c.) Prior to notification of compliance by the applicable external agency(ies), the Grantee may request disbursement of funds **only** for the following purposes: administrative, contractual, legal, engineering, or architectural costs incurred which are necessary to allow for compliance by the Grantee of requirements established by the external agency(ies). **FUNDS WILL NOT BE DISBURSED FOR LAND ACQUISITION OR ANY TYPE OF CONSTRUCTION OR OTHER ACTIVITY WHICH PHYSICALLY IMPACTS THE PROJECT SITE PRIOR TO RECEIPT BY THE GRANTOR OF THE REQUIRED NOTIFICATION FROM ALL APPLICABLE AGENCIES.**
- d.) If external sign-offs are indicated in this paragraph 37.3, disbursement of Grant Funds (whether advance or scheduled) are subject to the restrictions set forth by the External Sign-Off Provisions of this paragraph 37.3. Upon receipt of all required sign-offs, the Grantor's Accounting Division will be notified of authorization to disburse Grant Funds in accordance with the disbursement method indicated herein.

37.4 Prevailing Wage Act Compliance. The work to be performed under this Agreement is subject to the Prevailing Wage Act (820 ILCS 130/0.01 *et seq.*). Grantee shall comply with all requirements of the Prevailing Wage Act, including but not limited to: (a) inserting into all contracts for construction a stipulation to the effect that not less than the prevailing rate of wages as applicable to the project shall be paid to all laborers, workers, and mechanics performing work under the Award and requiring all bonds of contractors to include a provision as will guarantee the faithful performance of such prevailing wage clause as provided by contract and (b) all required reporting and documentation.

37.5. Compliance with Illinois Works Jobs Program Act. Grantee must comply with requirements in the Illinois Works Jobs Program Act (30 ILCS 559/Art. 20). For Awards with an estimated total project cost of \$500,000

or more, the Grantee will be required to comply with the Illinois Works Apprenticeship Initiative (30 ILCS 559/20-20 to 20-25) and all applicable administrative rules (see 14 Ill. Admin. Code Part 680). The "estimated total project cost" is a good faith approximation of the costs of an entire project being paid for in whole or in part by appropriated capital funds to construct a public work. Grantee must submit a Budget Supplement Form (available on the Grantor's website) to the Grantor within ninety (90) days of the execution of this Award. The goal of the Illinois Apprenticeship Initiative is that apprentices will perform either 10% of the total labor hours actually worked in each prevailing wage classification or 10% of the estimated labor hours in each prevailing wage classification, whichever is less. Grantee is permitted to seek from the Grantor a waiver or reduction of this goal in certain circumstances pursuant to 30 ILCS 559/20-20(b). The Grantee must ensure compliance for the life of the entire project, including during the term of the Award and after the Term ends, if applicable, and will be required to report on and certify its compliance.

37.6. Compliance with Business Enterprise Program. If applicable to this Grant, Grantee acknowledges that it is required to comply with the Business Enterprise Program for Minorities, Females, and Persons with Disabilities Act ("BEP") (30 ILCS 575/0.01 *et seq.*), which establishes a goal for contracting with businesses that have been certified as owned and controlled by persons who are minority, female or who have disabilities. Grantee shall maintain compliance with the BEP Utilization Plan submitted in conjunction with the Agreement and shall comply with all reporting requirements.

37.7. Compliance with the Employment of Illinois Workers on Public Works Act. Grantee acknowledges that it is required to comply with the Employment of Illinois Workers on Public Works Act (30 ILCS 570/0.01 *et seq.*) (the "Act"), which provides that whenever there is a period of excessive unemployment in Illinois (as defined by the Act), if the Grantee is using Grant Funds for (1) constructing or building any public works, or (2) performing the clean-up and on-site disposal of hazardous waste for the State of Illinois or any political subdivision of the State, then the Grantee shall employ at least 90% Illinois laborers on such project. Illinois laborers refers to any person who has resided in Illinois for at least 30 days and intends to become or remain an Illinois resident. Grantee may receive an exception from this requirement by submitting a request and supporting documents certifying that Illinois laborers are either not available or are incapable of performing the particular type of work involved. The certification must: (a) be submitted to the grant manager within the first quarter of the Award Term; (b) provide sufficient support that demonstrates the exception is met; (c) be signed by an authorized signatory of the Grantee; and (d) be approved by the grant manager. In addition, every contractor on a public works project or improvement or hazardous waste clean-up and on-site disposal project in this State may place on such work no more than 3 (or 6 in the case of a hazardous waste clean-up and on-site disposal project) of the contractor's regularly employed non-resident executive and technical experts.

37.8. Interest on Grant Funds for this Award. Because this Award may be subject to the Grantor's bondability guidelines, Grantee must comply with the interest requirements contained in Paragraph 4.7 and is not permitted to retain interest earned on Grant Funds, as stated in Paragraph 26.1, unless specifically notified by Grantor that Grantee may do so.

**State of Illinois
UNIFORM GRANT BUDGET TEMPLATE**

Agency:	Illinois Department of Commerce and Economic Opportunity	State FY:	2024
Grantee:	Village of Villa Park	DUNS Number:	46573184
NOFO Number:		CSFA Number:	
CSFA Description:			
		Grant Number:	21-413011

Section A: State of Illinois Funds	<u>Summary</u>	<u>Detail</u>
Revenues		
State of Illinois Grant Amount Requested	\$288,500.00	
Budget Expenditure Categories		
1. Personnel (200.430)		
2. Fringe Benefits (200.431)		
3. Travel (200.474)		
4. Equipment (200.439)		
5. Supplies (200.94)		
6. Contractual/Subawards (200.318 and .92)		
7. Consultant (200.459)		
8. Construction	\$288,500.00	
1219 PAVING/CONCRETE/MASONRY		\$19,400.00
1225 EXCAVATION/SITE PREP/DEMO		\$44,850.00
1229 PLUMBING		\$224,250.00
9. Occupancy (200.465)		
10. Research and Development (200.87)		
11. Telecommunications		
12. Training and Education (200.472)		
13. Direct Administrative Costs (200.413)		
14. Miscellaneous Costs		
15. Grant Exclusive Line Item(s)		
16. Total Direct Costs (add lines 1-15)	\$288,500.00	\$288,500.00
17. Total Indirect Costs (200.414)		
Rate: <input type="text"/> %		
Base: <input type="text"/>		
18. Total Costs State Grant Funds (Lines 16 and 17)	\$288,500.00	\$288,500.00

Grantee:

NOFO Number:

Grant Number:

SECTION A - Continued - Indirect Cost Rate Information

If your organization is requesting reimbursement for indirect costs on line 17 of the Budget Summary, please select one of the following options. If not reimbursement is being requested please consult your program office regarding possible match requirements.

Your organization may not have a Federally Negotiated Cost Rate Agreement. Therefore, in order for your organization to be reimbursed for the Indirect Costs from the State of Illinois your organization must either:

- a. Negotiate an Indirect Cost Rate with the State of Illinois' Indirect Cost Unit with guidance from you State Cognizant Agency on an annual basis;
- b. Elect to use the de minimis rate of 10% modified for total direct costs (MTDC) which may be used indefinitely on State of Illinois awards; or
- c. Use a Restricted Rate designated by programmatic or statutory policy (see Notice of Funding Opportunity or Restricted Rate Programs).

Select ONLY One:

- 1) Our Organization receives direct Federal funding and currently has a Negotiated Indirect Cost Rate Agreement (NICRA) with our federal Cognizant Agency. A copy of this agreement will be provided to the State of Illinois' Indirect Cost Unit for review and documentation before reimbursement is allowed. This NICRA will be accepted by all State of Illinois agencies up to any statutory, rule-based or programmatic restrictions or limitations.
- 2a) Our Organizations currently has a Negotiated Indirect Cost Rate Agreement (NICRA) with the State of Illinois that will be accepted by all State of Illinois agencies up to any statutory, rule-based or programmatic restrictions or limitations. Our Organization is required to submit a new Indirect Cost Rate Proposal to the Indirect Cost Unit within 6 months after the close of each fiscal year pursuant to 2 CFR 200, Appendix IV(c)(2)(c).
- 2b) Our Organization currently does not have a Negotiated Indirect Cost Rate Agreement (NICRA) with the State of Illinois. Our organization will submit our initial Indirect Cost Rate Proposal (ICRP) immediately after our Organization is advised that the State award will be made no later than 3 months after the effective date of the State award pursuant to 2 CFR 200 Appendix (C)(2)(b). The initial ICRP will be sent to the State of Illinois Indirect Cost unit.
- 3) Our Organization has never received a Negotiated Indirect Cost Rate Agreement from either the federal government or the State of Illinois and elects to charge the de minimis rate of 10% modified total direct cost (MTDC) which may be used indefinitely on State of Illinois awards pursuant to 2 CRF 200.414 (C)(4)(f) and 200.68.
- 4) For Restricted Rate Programs, our Organization is using a restricted indirect cost rate that:
 - is included as a "Special Indirect Cost Rate" in the NICRA, pursuant to 2 CFR 200 Appendix IV(5); or
 - complies with other statutory policies.
- 5) No reimbursement of Indirect Cost is being requested.

Rate: %

Basic Negotiated Indirect Cost Rate Information (Use only if option 1 or 2(a), above is selected.)

Period Covered By NICRA: From: To: Approving Federal or State Agency:

Indirect Cost Rate: % The Distribution Base Is:

Grantee: Village of Villa Park

NOFO Number: 0

Grant Number: 21-413011

By signing this report, I certify to the best of my knowledge and belief that the report is true, complete and accurate and that any false, fictitious or fraudulent information or the omission of any material fact could result in the immediate termination of my grant award(s).

Institution/Organization: Village of Villa Park
Signature: Nick Cuzzone
Printed Name: Nick Cuzzone
Title: President
Phone: 773.263.8031
Date: 12/14/2023

Institution/Organization: Village of Villa Park
Signature: Chereshaw D
Printed Name: Chereshaw D
Title: FINANCE DIRECTOR
Phone: 630-592-6064
Date: 12/14/23

Note: The State Awarding Agency may change required signers based on the grantee's organizational structure. The required signers must have the authority to enter into contractual agreements on the behalf of the organization.

CERTIFICATION	STATE OF ILLINOIS UNIFORM CAPITAL GRANT BUDGET TEMPLATE	AGENCY: Commerce & Economic Opportunity
Organization Name: Village of Villa Park	CSFA Description: Installation and/or Replacement of Utilities	NOFO #
CSFA #: 420-00-2662	DUNS # and UEI # 46573184	Fiscal Year(s): 2023

(2 CFR 200.415)

"By signing this report, I certify to the best of my knowledge and belief that the report is true, complete, and accurate and that any false, fictitious, or fraudulent information or the omission of any material fact, could result in the immediate termination of my grant award(s).

Village of Villa Park
 Institution/Organization

Signature

 Name of Official

Finance Director
 Title
 Chief Financial Officer (or equivalent)
 5/25/2023

Date of Execution

Village of Villa Park
 Institution/Organization

Signature

 Name of Official

Village Manager
 Title
 Executive Director (or equivalent)
 5/25/2023

Date of Execution

Note: The State awarding agency may change required signers based on the grantee's organizational structure. The required signers must have the authority to enter into contractual agreements on behalf of the organization.

F.A. RTE.	SECTION	COUNTY	TOTAL SHEETS	SHEET NO.
		DUPAGE	15	1
		ILLINOIS	CONTRACT NO.	

VILLAGE OF VILLA PARK, ILLINOIS

DCEO DRAINAGE IMPROVEMENT PROJECT (VARIOUS LOCATIONS)

ELLSWORTH DITCH, RIDGE ROAD, THIRD AVENUE AND VERMONT STREET, AND 205 S. YALE AVENUE DUPAGE COUNTY

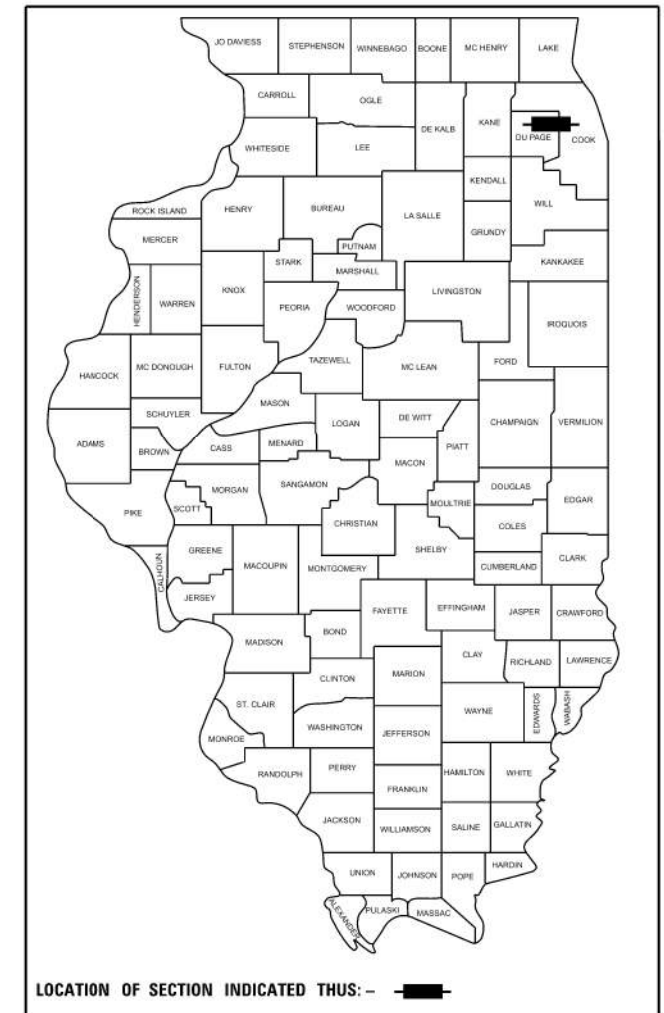

INDEX OF SHEETS:

- 1 COVER SHEET
- 2 GENERAL NOTES
- 3-5 SUMMARY OF QUANTITIES
- 6 ELLSWORTH DITCH REGRADING PLAN
- 7-8 RIDGE ROAD DRAINAGE IMPROVEMENTS
- 9 THIRD AVENUE AND VERMONT STREET DRAINAGE IMPROVEMENTS
- 10 205 S. YALE AVENUE DRAINAGE IMPROVEMENTS
- 11-15 CONSTRUCTION DETAILS

FOR LIST OF HIGHWAY STANDARDS, SEE SHEET NO. 2

ELLSWORTH DITCH GROSS LENGTH = 379.82 FT. = 0.07 MILE
 ELLSWORTH DITCH NET LENGTH = 379.82 FT. = 0.07 MILE
 RIDGE ROAD GROSS LENGTH = 778.44 FT. = 0.15 MILE
 RIDGE ROAD NET LENGTH = 778.44 FT. = 0.15 MILE
 THIRD AVENUE AND VERMONT STREET GROSS LENGTH = 102.10 FT. = 0.02 MILE
 THIRD AVENUE AND VERMONT STREET NET LENGTH = 102.10 FT. = 0.02 MILE
 205 S. YALE AVENUE GROSS LENGTH = 212.76 FT. = 0.04 MILE
 205 S. YALE AVENUE NET LENGTH = 212.76 FT. = 0.04 MILE

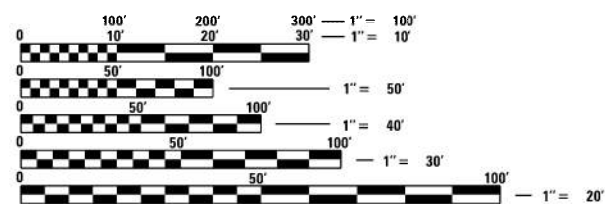
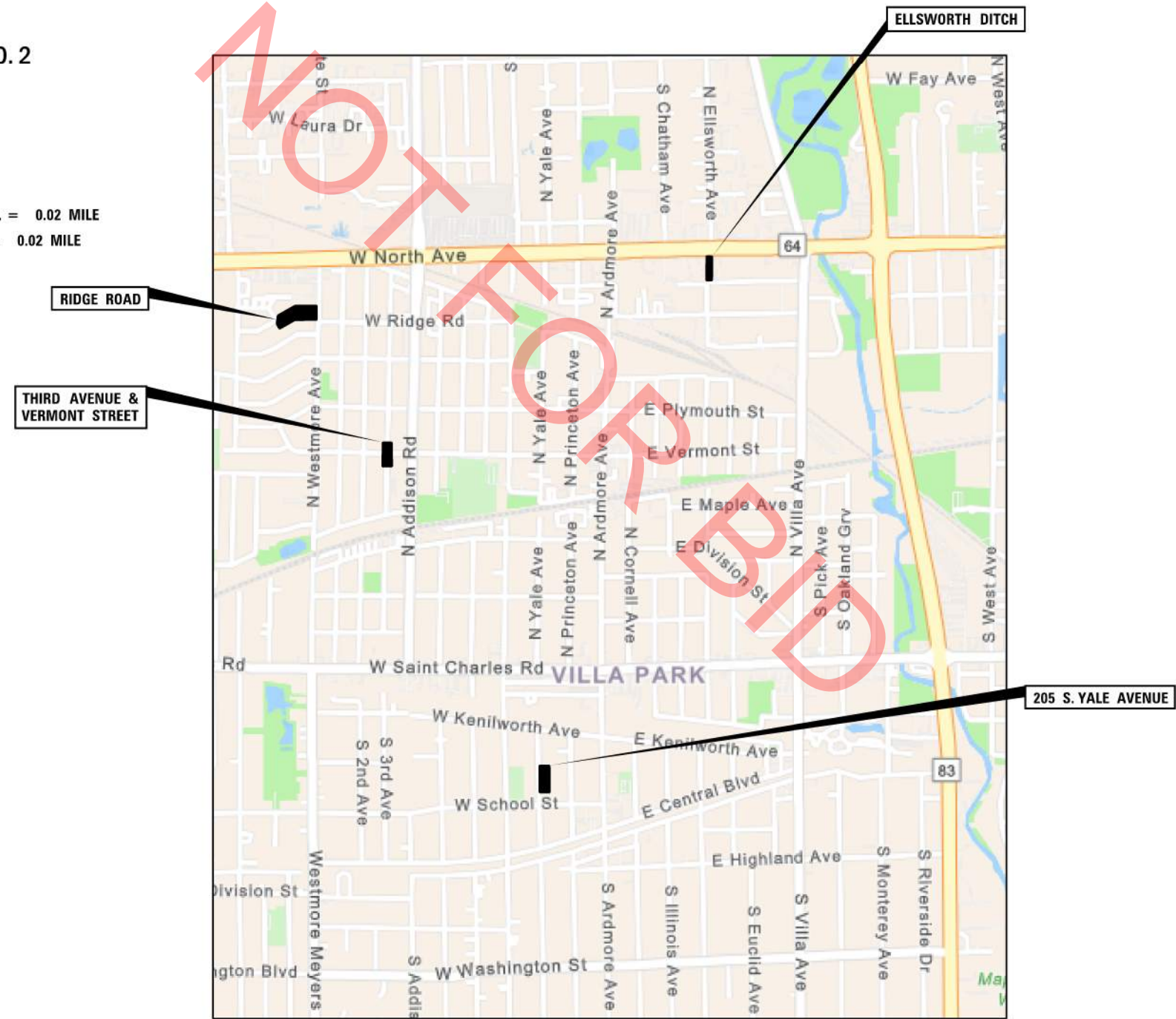

PROJECT TOTAL GROSS LENGTH = 1473.12 FT. = 0.28 MILE
 PROJECT TOTAL NET LENGTH = 1473.12 FT. = 0.28 MILE



FULL SIZE PLANS HAVE BEEN PREPARED USING STANDARD ENGINEERING SCALES. REDUCED SIZED PLANS WILL NOT CONFORM TO STANDARD SCALES. IN MAKING MEASUREMENTS ON REDUCED PLANS, THE ABOVE SCALES MAY BE USED.

J.U.L.I.E.
 JOINT UTILITY LOCATION INFORMATION FOR EXCAVATION
 1-800-892-0123
 OR 811



V3
 JASON D. HOLY
 # 062-059941

 DATE: 9/25/2024

 EXPIRATION DATE: 11-30-2025

GENERAL NOTES

- ALL EXISTING TOPOGRAPHY, UNDERGROUND UTILITIES, STRUCTURES AND ASSOCIATED FACILITIES SHOWN ON THESE DRAWINGS HAVE BEEN PLOTTED FROM AVAILABLE SURVEYS AND RECORDS. THEREFORE, THEIR LOCATIONS AND ELEVATIONS MUST BE CONSIDERED APPROXIMATE ONLY. THERE MAY BE OTHER FACILITIES, THE EXISTENCE OF WHICH ARE NOT PRESENTLY KNOWN. THE EXACT LOCATIONS AND ELEVATIONS ARE TO BE VERIFIED BY THE CONTRACTOR.
- BEFORE STARTING ANY EXCAVATION, THE CONTRACTOR SHALL CALL "JULIE" AND THE VILLAGE OF VILLA PARK FOR FIELD LOCATIONS OF BURIED UTILITIES 48 HOURS IN ADVANCE OF WORK.

<u>ELECTRIC</u> COMMONWEALTH EDISON 2 LINCOLN CENTER OAKBROOK TERRACE, IL 60181 (630) 576-7094	<u>CABLE TV</u> COMCAST CABLE COMMUNICATIONS MARTHA GIERAS 2001 YORK ROAD OAK BROOK, IL 60523 (224) 229-5862	<u>GAS</u> NICOR GAS 1844 FERRY RD. NAPERVILLE, IL 60563 (630) 388-2362
--	---	---

<u>TELEPHONE</u> AT&T KARI MARTIN 1000 COMMERCE DRIVE, FLOOR 1 OAK BROOK, IL 60523 (630) 573-5789	<u>WATER AND SEWER</u> VILLAGE OF VILLA PARK KEVIN MANTELS 11 WEST HOME AVENUE VILLA PARK, IL 60181 (630) 834-8505
--	---

- IT SHALL BE THE CONTRACTOR'S RESPONSIBILITY TO FIELD CHECK ALL DIMENSIONS AND ELEVATIONS OF EXISTING UTILITY LINES AND STRUCTURES THAT MAY BE IMPACTED BY THE PROPOSED WORK PRIOR TO ORDERING MATERIAL OR BEGINNING CONSTRUCTION. ANY DISCREPANCIES FROM THE PLANS SHALL BE REPORTED TO THE ENGINEER IMMEDIATELY.
- ANY DAMAGE TO EXISTING UTILITIES SHALL BE REPAIRED BY THE UTILITY COMPANY AT THE CONTRACTOR'S EXPENSE.
- THE CONTRACTOR SHALL USE ALL NECESSARY PRECAUTIONARY AND PROTECTIVE MEASURES REQUIRED TO MAINTAIN AND PROTECT EXISTING UTILITIES, SEWERS, MAINS AND APPURTENANCES THAT MUST BE KEPT IN OPERATION. IN PARTICULAR, THE CONTRACTOR SHALL TAKE ADEQUATE MEASURES TO PREVENT THE UNDERMINING OF UTILITIES, SEWERS AND MAINS WHICH WILL REMAIN IN SERVICE. THE CONTRACTOR SHALL COORDINATE WITH THE ENGINEER AND UTILITY COMPANY IF IT IS DETERMINED THAT TEMPORARY BRACING OR SUPPORT OF THE UTILITIES IS REQUIRED. THE PROTECTION AND/OR TEMPORARY BRACING OR SUPPORT OF UTILITIES WILL NOT BE PAID FOR SEPARATELY BUT SHALL BE CONSIDERED AS INCLUDED IN THE UNIT BID PRICES OF THE CONTRACT AND NO ADDITIONAL COMPENSATION WILL BE ALLOWED.
- THE CONTRACTOR WILL NOT BE PERMITTED TO SET UP A YARD OR FIELD OFFICE ON STATE OR VILLAGE PROPERTY WITHOUT PRIOR WRITTEN PERMISSION OF THE VILLAGE.
- ALL APPLICABLE PROVISIONS OF THE CURRENT OCCUPATIONAL SAFETY AND HEALTH ACT ARE HEREIN INCORPORATED BY REFERENCE.
- EXCEPT WHERE MODIFIED BY THE CONTRACT DOCUMENTS, ALL WORK PROPOSED HEREON SHALL BE IN ACCORDANCE WITH THE FOLLOWING SPECIFICATIONS WHICH ARE HEREBY MADE A PART HEREOF:
 - "STANDARD SPECIFICATIONS FOR ROAD AND BRIDGE CONSTRUCTION IN ILLINOIS," AS PREPARED BY IDOT, LATEST EDITION.
 - "SUPPLEMENTAL SPECIFICATIONS AND RECURRING SPECIAL PROVISIONS," AS PREPARED BY IDOT, LATEST EDITION.
 - THE LATEST EDITIONS OF THE MUNICIPAL CODE AND STANDARDS OF THE VILLAGE OF VILLA PARK.
 - THE ILLINOIS ACCESSIBILITY CODE.
 - "MANUAL ON UNIFORM TRAFFIC CONTROL DEVICES FOR STREETS AND HIGHWAYS," LATEST EDITION.
 - "STANDARD SPECIFICATIONS FOR WATER AND SEWER MAIN CONSTRUCTION IN ILLINOIS AS PUBLISHED BY THE IEPA," LATEST EDITION.
 - ILLINOIS RECOMMENDED STANDARDS FOR SEWAGE WORKS," AS PUBLISHED BY THE IEPA, LATEST EDITION.
 - "MANUAL OF TEST PROCEDURES FOR MATERIALS," LATEST EDITION
 - "ILLINOIS URBAN MANUAL," LATEST EDITION

GENERAL NOTES (CONTD.)

- THE ENGINEER AND VILLAGE OF VILLA PARK ARE NOT RESPONSIBLE FOR THE CONSTRUCTION MEANS, METHODS, TECHNIQUES, SEQUENCES OR PROCEDURES, TIME OF PERFORMANCE, PROGRAMS OR ANY SAFETY PRECAUTIONS USED BY THE CONTRACTOR. THE CONTRACTOR IS SOLELY RESPONSIBLE FOR EXECUTION OF HIS/HER WORK IN ACCORDANCE WITH THE CONTRACT DOCUMENTS AND SPECIFICATIONS.
- THE CONTRACTOR IS RESPONSIBLE FOR HAVING A SET OF "APPROVED" ENGINEERING PLANS WITH THE LATEST REVISION DATE ON THE JOB SITE PRIOR TO THE START OF CONSTRUCTION AND AT ALL TIMES DURING CONSTRUCTION.
- AREAS OUTSIDE THE R.O.W. LINE OR CONSTRUCTION LIMIT LINE IMPACTED BY OPERATIONS OF THE CONTRACTOR SHALL BE RETURNED TO THE STATE IT WAS FOUND PRIOR TO NEW CONSTRUCTION, EXCEPT WHERE NEW WORK IS SHOWN.
- CONTRACTOR SHALL MAINTAIN ACCESS TO ALL PROPERTIES AND SIDE ROADS AT ALL TIMES DURING CONSTRUCTION OPERATIONS, UNLESS OTHERWISE NOTED ON PLANS.
- ALL PROPOSED AND EXISTING LOCATIONS, ELEVATIONS OF UTILITIES, AND IMPROVEMENTS ARE APPROXIMATE AND SHOULD BE VERIFIED PRIOR TO THE COMMENCEMENT OF WORK.

REMOVALS AND PAVING NOTES

- ALL EXISTING PAVEMENT OR CONCRETE CURB AND GUTTER TO BE REMOVED SHALL BE SAWCUT ALONG LIMITS OF PROPOSED REMOVAL BEFORE COMMENCEMENT OF PAVEMENT REMOVAL. THE COST OF THE SAW CUT SHALL BE INCLUDED IN THE COST OF ITEM BEING REMOVED.
- REMOVED PAVEMENT, SIDEWALK, CURB AND GUTTER, ETC. SHALL BE DISPOSED OF BY THE CONTRACTOR AT THEIR OWN EXPENSE. THE CONTRACTOR SHALL BE RESPONSIBLE FOR PROVIDING AN OFF-SITE DUMP SITE AT THEIR OWN EXPENSE.
- NO HOLES ARE TO BE LEFT OPEN IN THE PAVEMENT OR PARKWAY OVER A HOLIDAY, WEEKEND OR AFTER 3:00 P.M. ON THE DAY PRECEDING A HOLIDAY OR A WEEKEND.
- STREET PAVING AND CURBS TO REMAIN SHALL BE PROTECTED FROM DAMAGE. IF DAMAGED, IT SHALL BE REPLACED PROMPTLY IN CONFORMANCE WITH THE MUNICIPALITY OR IDOT STANDARD SPECIFICATIONS IN MATERIALS AND WORKMANSHIP AND AT THE CONTRACTOR'S EXPENSE.
- ALL CURB RADII REFER TO EDGE OF PAVMENT UNLESS OTHERWISE NOTED.
- ASPHALT JOINTS FOR BINDER COURSES ARE TO BE STAGGERED.
- PROPOSED ELEVATIONS INDICATE FINISHED CONDITIONS. FOR ROUGH GRADING ELEVATIONS ALLOW FOR THICKNESS OF PROPOSED PAVING (ROADS, WALKS, DRIVES, ETC.) OR TOPSOIL AS INDICATED ON DRAWINGS.

MAINTENANCE OF TRAFFIC NOTES

- TRAFFIC CONTROL AND PROTECTION SHALL BE PERFORMED IN ACCORDANCE WITH THE MAINTENANCE OF TRAFFIC NOTES AND PROTECTION SECTION 701 OF THE STANDARD SPECIFICATIONS.
- THE CONTRACTOR SHALL BE RESPONSIBLE FOR THE INSTALLATION AND MAINTENANCE OF ADEQUATE SIGNS, TRAFFIC CONTROL DEVICES AND WARNING DEVICES TO INFORM AND PROTECT THE PUBLIC DURING ALL PHASES OF CONSTRUCTION. BARRICADES AND WARNING SIGNS SHALL BE PROVIDED IN ACCORDANCE WITH ARTICLE 107.14 OF THE IDOT STANDARD SPECIFICATIONS. ALL TRAFFIC CONTROL WORK SHALL BE DONE IN ACCORDANCE WITH IDOT "MANUAL ON UNIFORM TRAFFIC CONTROL DEVICES."
- ALL SIGNS SHALL BE IN ACCORDANCE WITH IDOT STANDARD SPECIFICATIONS, LATEST EDITION, AND THE MANUAL ON UNIFORM TRAFFIC CONTROL DEVICES, LATEST EDITION.
- THE COST OF SUPPLYING, ERECTING, AND MAINTAINING TRAFFIC CONTROL DEVICES, LIGHTS, AND SIGNS SHALL BE INCLUDED IN THE CONTRACT PRICE FOR TRAFFIC CONTROL AND PROTECTION, SPECIAL.
- THE CONTRACTOR SHALL PERFORM ALL WORK BETWEEN THE WEEKDAY HOURS OF 7:00AM AND 5:00PM, UNLESS OTHERWISE ALLOWED BY THE ENGINEER.
- ALL TRAFFIC CONTROL DEVICES SHALL BE MAINTAINED THROUGH THE COMPLETION OF THE CONTRACT.
- SIGNAGE SHOWN ON THE MOT PLANS THAT ARE IN CONFLICT WITH EXISTING SIGNAGE WILL BE REQUIRED TO BE RELOCATED. ALL SIGNAGE SHALL BE KEPT IN THE CONDITION IT WAS REMOVED IN, OR SHALL BE REPLACED IN KIND AT THE EXPENSE OF THE CONTRACTOR. SIGNS ARE TO BE REINSTALLED ONCE THE PROJECT IS COMPLETE AND IS INCLUDED IN THE CONTRACT PRICE FOR TRAFFIC CONTROL AND PROTECTION SPECIAL.
- WORK ZONE SIGNING AND STRIPING SHALL BE DONE IN ACCORDANCE WITH IDOT STANDARD 701501, 701901, AND AS SHOWN IN THE PLANS.
- THE AREA THE CONTRACTOR SHALL BE INSTALLING SEWERS SHALL USE HIGHWAY STANDARD 701501 WITH FLAGGERS. THE ROAD SHALL BE OPEN TO ONE-WAY TRAFFIC AT THE END OF THE DAY. THE HOLE SHALL BE PROTECTED AND ALL DRIVEWAYS SHALL BE OPEN.

DRAINAGE NOTES

- DURING CONSTRUCTION, THE CONTRACTOR SHALL MAINTAIN ALL SURFACE DRAINAGE WITHIN THE PROJECT LIMITS. ALL STORM FLOW MUST BE MAINTAINED AT ALL TIMES, UNLESS OTHERWISE DIRECTED BY ENGINEER.
- WHENEVER LOOSE MATERIAL IS DEPOSITED IN THE FLOW LINE OF GUTTERS, DRAINAGE STRUCTURES, DITCHES ETC., SUCH THAT THE NATURAL FLOW LINE OF WATER IS OBSTRUCTED, THE LOOSE MATERIAL SHALL BE REMOVED AT THE CLOSE OF EACH WORKING DAY. THIS WORK SHALL BE INCLUDED IN THE COST OF THE CONTRACT.
- ANY EXISTING DRAINAGE FACILITIES DISTURBED OR DAMAGED DURING CONSTRUCTION SHALL BE REPAIRED OR REPLACED BY THE CONTRACTOR AT THEIR EXPENSE. THIS WORK SHALL BE PERFORMED TO THE SATISFACTION OF THE ENGINEER.
- OFFSETS AND TOP OF FRAME OR LID ELEVATIONS FOR STRUCTURES LOCATED IN THE GUTTER ARE GIVEN AT THE EDGE OF PAVEMENT.
- TOP OF FRAME ("RIM") ELEVATIONS GIVEN ON THE PLANS ARE ONLY TO ASSIST THE CONTRACTOR IN DETERMINING THE APPROXIMATE OVERALL HEIGHT OF EACH STRUCTURE. FRAMES ON ALL NEW STRUCTURES SHALL BE ADJUSTED TO THE FINAL ELEVATIONS OF THE AREAS IN WHICH THEY ARE LOCATED, AS PART OF THE STRUCTURE COST.
- UNLESS OTHERWISE INDICATED ON THE PLANS, STORM SEWER PIPE SHALL BE REINFORCED CONCRETE PIPE IN CONFORMANCE WITH IDOT STANDARD SPECIFICATIONS DETERMINATION FOR PIPE CLASS AND CONFORM TO ASTM C-76. JOINT SPECIFICATIONS SHALL MEET ASTM C-443.
- ALL POLYVINYL CHLORIDE (PVC) PIPE SHALL BE 6-INCH TO 15-INCH DIAMETER SDR 26 IN CONFORMANCE WITH IDOT STANDARD SPECIFICATIONS DETERMINATION FOR PIPE CLASS AND CONFORM TO ASTM D-2241. JOINT SPECIFICATIONS SHALL MEET ASTM D-3212.
- THE COST OF MAKING EXISTING STORM SEWER CONNECTIONS TO PROPOSED DRAINAGE STRUCTURES SHALL BE INCLUDED IN THE COST OF THE DRAINAGE STRUCTURE BEING INSTALLED.
- PROVIDE TRENCH BACKFILL IN ACCORDANCE WITH IDOT SPECIFICATIONS.
- THE CONTRACTOR SHALL FURNISH ALL LABOR, EQUIPMENT AND MATERIAL NECESSARY FOR DEWATERING TRENCH EXCAVATIONS AS WELL AS SHORING TRENCH WALLS DURING UTILITY AND STORM SEWER OPERATIONS. THE COST OF COMPLIANCE WITH THE ABOVE, SHALL BE INCLUDED IN THE COST OF THE UTILITY BEING INSTALLED.
- ALL OPEN-LID DRAINAGE STRUCTURES WITHIN THE VICINITY OF THE WORK AREA SHALL BE FITTED WITH AN INLET FILTER FOR THE DURATION OF CONSTRUCTION.

IDOT HIGHWAY STANDARDS

280001-07	TEMPORARY EROSION CONTROL SYSTEMS
602001-02	CATCH BASIN TYPE A
604001-05	FRAMES AND LIDS TYPE 1
604051-04	FRAME AND GRATE TYPE 11
701501-06	URBAN LANE CLOSURE, 2L, 2W, UNDIVIDED
701901-09	TRAFFIC CONTROL DEVICES

IDOT DISTRICT ONE STANDARDS

TC-13	TYPICAL PAVEMENT MARKINGS
-------	---------------------------

VILLAGE STANDARDS

ROAD - 02	COMBINATION CONCRETE CURB AND GUTTER
SANITARY - 03	PIPE INSTALLATION
SANITARY - 05	STANDARD MANHOLE
STORM - 01	CATCH BASIN TYPE "C"
STORM - 15	INLET TYPE "A"
STORM - 21	KOR-N-TEE CONNECTION
STREET - 03	TYPICAL DRIVEWAY APPROACH
STREET - 07	TYPICAL PAVEMENT CROSS-SECTION

MISCELLANEOUS DETAILS

CLASS C PATCHES, SPECIAL (ROADWAYS)
CLASS D PATCHES, SPECIAL (ROADWAYS)
CLEANOUT DETAIL
P.C.C. SIDEWALK, 5 INCH

MODEL: D:\info\... FILE NAME: ...



V3 Companies
7325 Janes Avenue
Woodridge, IL 60517
630.724.9200 phone
630.724.9202 fax
www.v3co.com

USER NAME = lryanbich	DESIGNED - LRY	REVISED -
PLOT SCALE =	DRAWN - LRY	REVISED -
PLOT DATE = 9/25/2024	CHECKED - JDH	REVISED -
	DATE - 9/25/2024	REVISED -

DCEO DRAINAGE IMPROVEMENT PROJECT (VARIOUS LOCATIONS)
VILLA PARK

GENERAL NOTES
ILLINOIS SCALE: SHEET 1 OF 1 SHEETS STA. TO STA.

F.A. RTE.	SECTION	COUNTY	TOTAL SHEETS	SHEET NO.
			15	2
CONTRACT NO. XXXX				
		ILLINOIS	FED. AID PROJECT	

SPECIAL PROVISION	ITEM	UNIT	BASE BID		ALT BID #1	ALT BID #2	TOTAL QUANTITY
			ELLSWORTH DITCH QUANTITY	RIDGE RD QUANTITY	THIRD AVE AND VERMONT ST QUANTITY	YALE AVE QUANTITY	
	EARTH EXCAVATION	CU YD	258				258
	REMOVAL AND DISPOSAL OF UNSUITABLE MATERIAL	CU YD	229				229
*	TRENCH BACKFILL	CU YD		1,004	76	50	1,130
	TOPSOIL FURNISH AND PLACE, 4"	SQ YD	968				968
	GRADING AND SHAPING DITCHES	FOOT	407				407
	SEEDING, CLASS 4A	ACRE	0.20				0.20
	EROSION CONTROL BLANKET	SQ YD	968				968
	INLET AND PIPE PROTECTION	EACH	1				1
*	INLET FILTERS	EACH		7	6	4	17
	STONE RIPRAP, CLASS A3	SQ YD	46				46
	FILTER FABRIC	SQ YD	354				354
	AGGREGATE BASE COURSE, TYPE B 6"	SQ YD		93	25		118
*	PORTLAND CEMENT CONCRETE SIDEWALK 5 INCH	SQ FT		1,580	180		1,727
*	DETECTABLE WARNINGS	SQ FT		10	20		20
*	DRIVEWAY PAVEMENT REMOVAL	SQ YD		93	25		118
*	SIDEWALK REMOVAL	SQ FT		1,580	180		1,727
	STORM SEWER REMOVAL 18"	FOOT		49			49
	MANHOLES TO BE RECONSTRUCTED	EACH		1		1	2
	INLETS TO BE RECONSTRUCTED	EACH		2			2

NOT FOR BID

MODEL: D:\info\11\2024\11001\100 DCEO H22065 Grant Projects\Drawings\Main\CADD_Sheets\110110-10-HS0001.dgn



V3 Companies
7325 Janes Avenue
Woodridge, IL 60517
630.724.9200 phone
630.724.9202 fax
www.v3co.com

USER NAME = lryanbich
PLOT SCALE =
PLOT DATE = 9/25/2024

DESIGNED - LRY
DRAWN - LRY
CHECKED - JDH
DATE - 9/25/2024

REVISED -
REVISED -
REVISED -
REVISED -

DCEO DRAINAGE IMPROVEMENT PROJECT (VARIOUS LOCATIONS)

VILLA PARK ILLINOIS

SUMMARY OF QUANTITIES

SCALE: SHEET 1 OF 3 SHEETS STA. TO STA.

F.A. RTE.	SECTION	COUNTY	TOTAL SHEETS	SHEET NO.
		DUPAGE	15	3
CONTRACT NO. XXXX				
		ILLINOIS	FED. AID PROJECT	

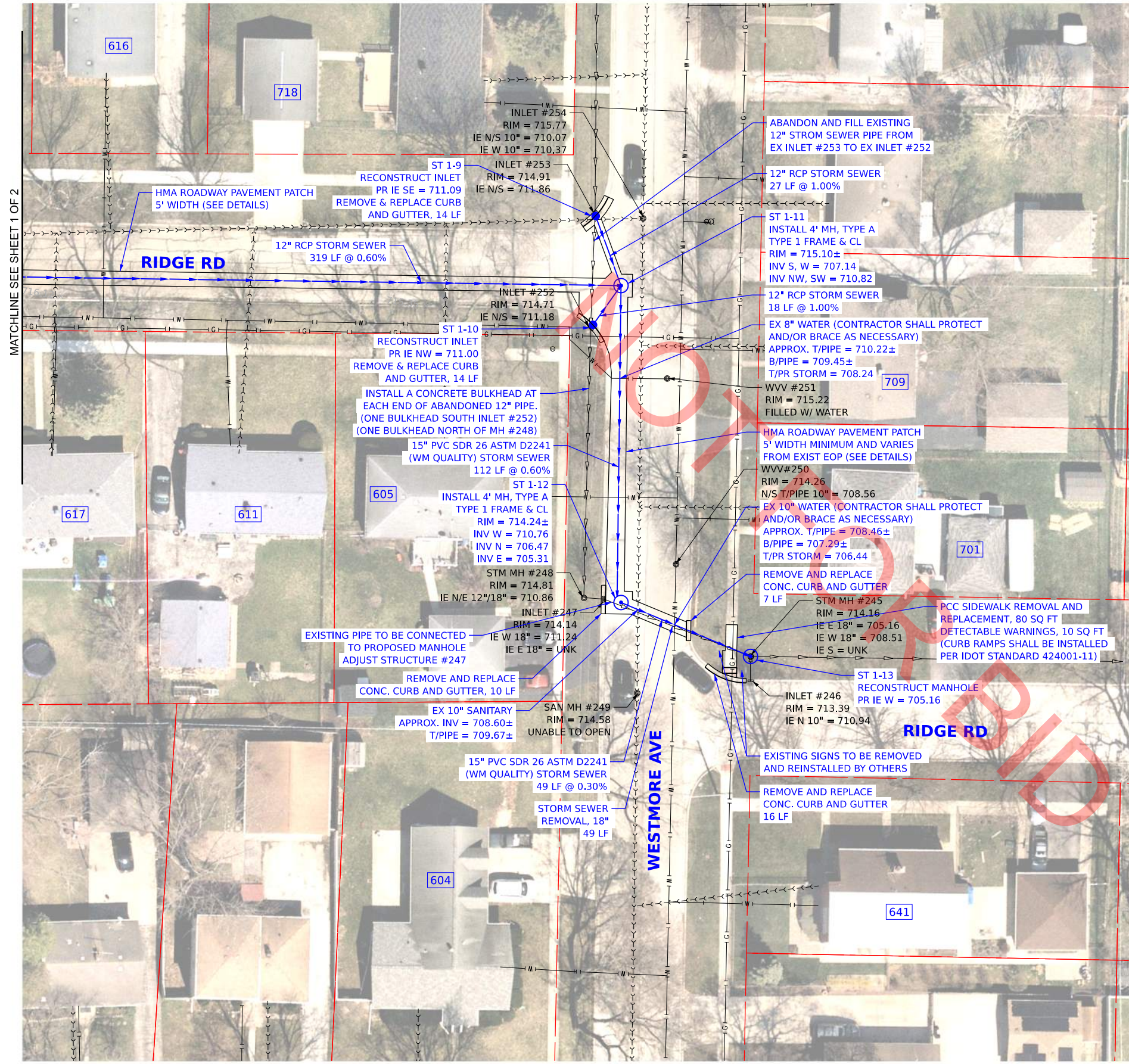

MATCHLINE SEE SHEET 1 OF 2

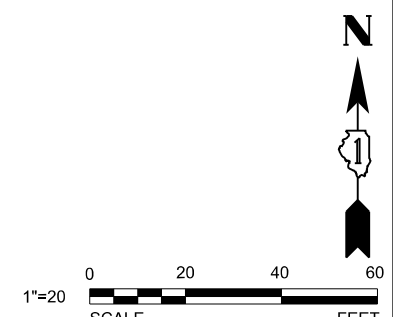

MODEL: D:\info\11\2020\11\130 DCEO H220655 Grant Projects\Drawings\Main\CADD_Sheets\110718\hsh\hsh-dp02.dgn
FILE NAME: 110718\110718_130 DCEO H220655 Grant Projects\Drawings\Main\CADD_Sheets\110718\hsh\hsh-dp02.dgn

V3
V3 Companies
7325 Janes Avenue
Woodridge, IL 60517
630.724.9200 phone
630.724.9202 fax
www.v3co.com

USER NAME = njanbich	DESIGNED - LRY	REVISED -
DRAWN - LRY	REVISED -	
CHECKED - JDH	REVISED -	
DATE - 9/25/2024	REVISED -	

DCEO DRAINAGE IMPROVEMENT PROJECT (VARIOUS LOCATIONS)

VILLA PARK

RIDGE ROAD DRAINAGE IMPROVEMENTS

SCALE: 1"=20'

SHEET 2 OF 2 SHEETS STA. TO STA.

F.A. RTE.	SECTION	COUNTY	TOTAL SHEETS	SHEET NO.
		DUPAGE	15	8
CONTRACT NO. XXXX				
ILLINOIS FED. AID PROJECT				

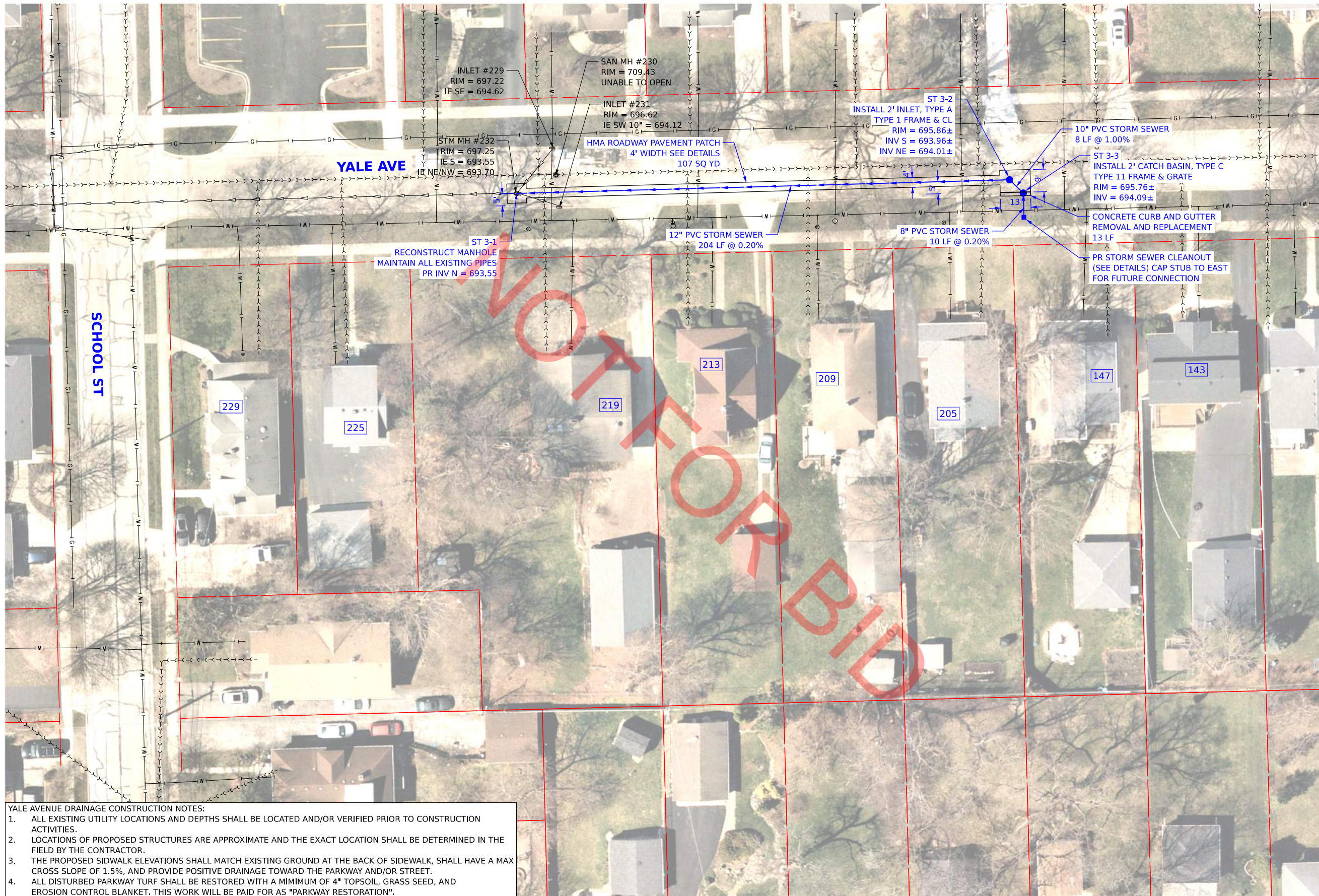

YALE AVENUE DRAINAGE CONSTRUCTION NOTES:

1. ALL EXISTING UTILITY LOCATIONS AND DEPTHS SHALL BE LOCATED AND/OR VERIFIED PRIOR TO CONSTRUCTION ACTIVITIES.
2. LOCATIONS OF PROPOSED STRUCTURES ARE APPROXIMATE AND THE EXACT LOCATION SHALL BE DETERMINED IN THE FIELD BY THE CONTRACTOR.
3. THE PROPOSED SIDEWALK ELEVATIONS SHALL MATCH EXISTING GROUND AT THE BACK OF SIDEWALK, SHALL HAVE A MAX CROSS SLOPE OF 1.5%, AND PROVIDE POSITIVE DRAINAGE TOWARD THE PARKWAY AND/OR STREET.
4. ALL DISTURBED PARKWAY TURF SHALL BE RESTORED WITH A MINIMUM OF 4" TOPSOIL, GRASS SEED, AND EROSION CONTROL BLANKET. THIS WORK WILL BE PAID FOR AS "PARKWAY RESTORATION".

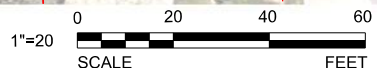

MODEL: D:\proj\1100718017\1100718017_130_DCEO_H22085_Grant_Parkway\Drawings\Main\CADD_Sheet\11017180171801718017.dwg
 FILE NAME: 1100718017_130_DCEO_H22085_Grant_Parkway\Drawings\Main\CADD_Sheet\11017180171801718017.dwg

V3 Companies 7325 Janes Avenue Woodridge, IL 60517 630.724.9200 phone 630.724.9202 fax www.v3co.com	USER NAME = njanbich DESIGNED - LRY DRAWN - LRY CHECKED - JDH DATE - 9/25/2024	REVISED - REVISED - REVISED - REVISED -	VILLA PARK ILLINOIS	DCEO DRAINAGE IMPROVEMENT PROJECT (VARIOUS LOCATIONS) SCALE: 1"=20"	SHEET 1 OF 1 SHEETS STA. TO STA.	205 S. YALE AVENUE DRAINAGE IMPROVEMENTS F.A. RTE. SECTION COUNTY TOTAL SHEETS SHEET NO. DUPAGE 15 10 CONTRACT NO. XXXX	ILLINOIS FED. AID PROJECT
	PLOT SCALE = PLOT DATE = 9/25/2024	DATE - 9/25/2024	REVISED -	ILLINOIS	SHEET 1 OF 1 SHEETS STA. TO STA.	CONTRACT NO. XXXX	ILLINOIS FED. AID PROJECT

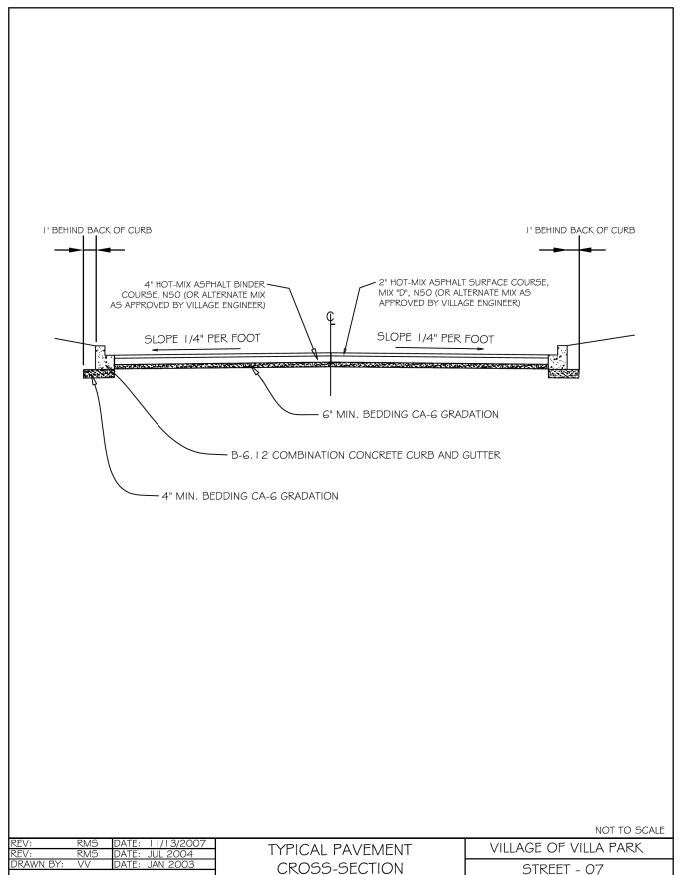
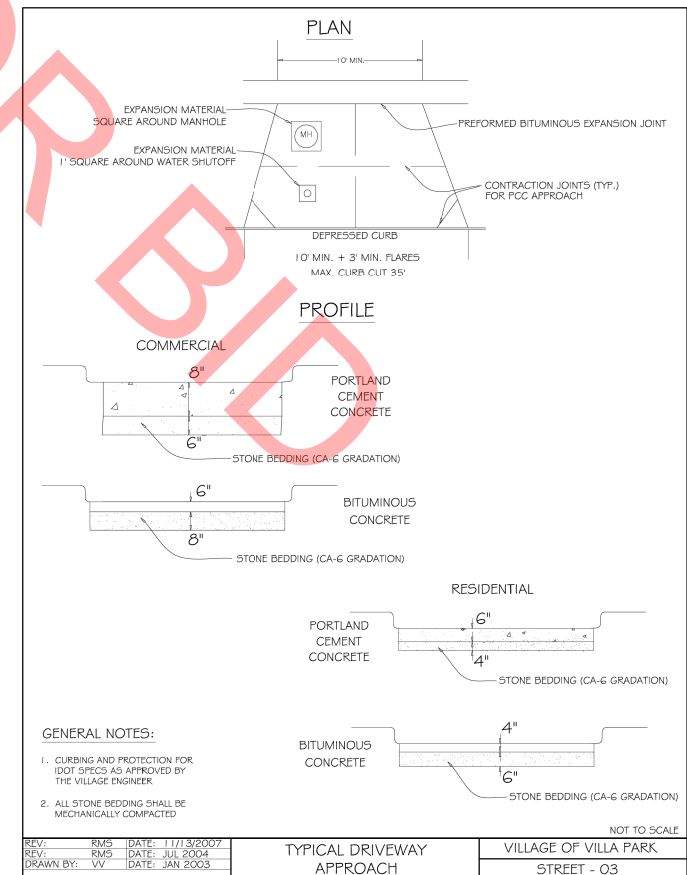
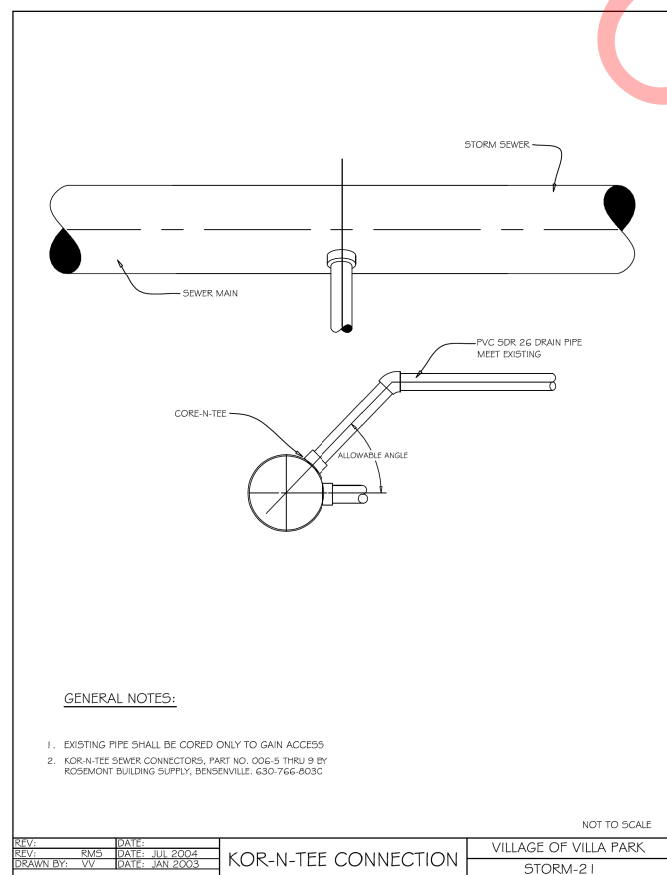
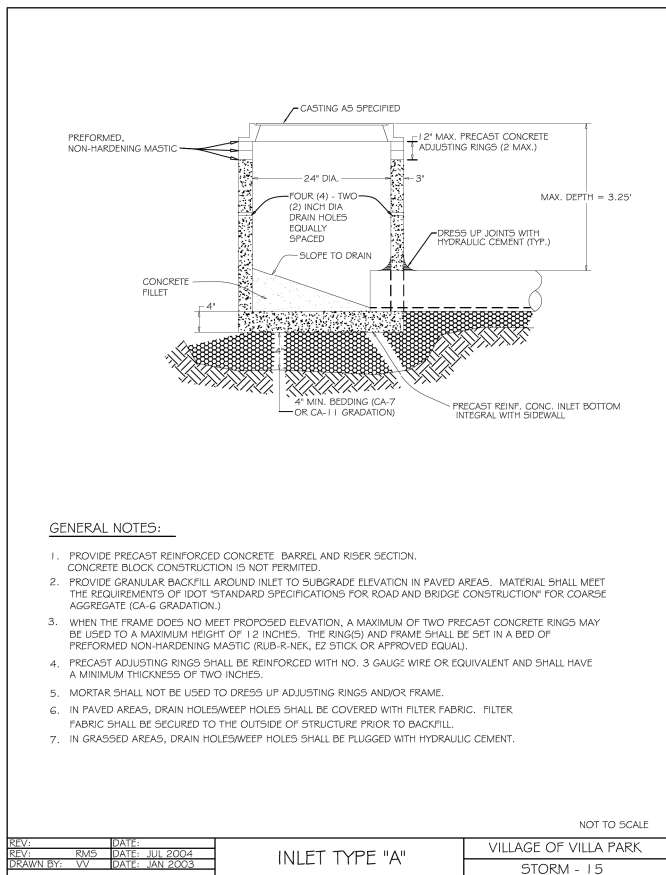
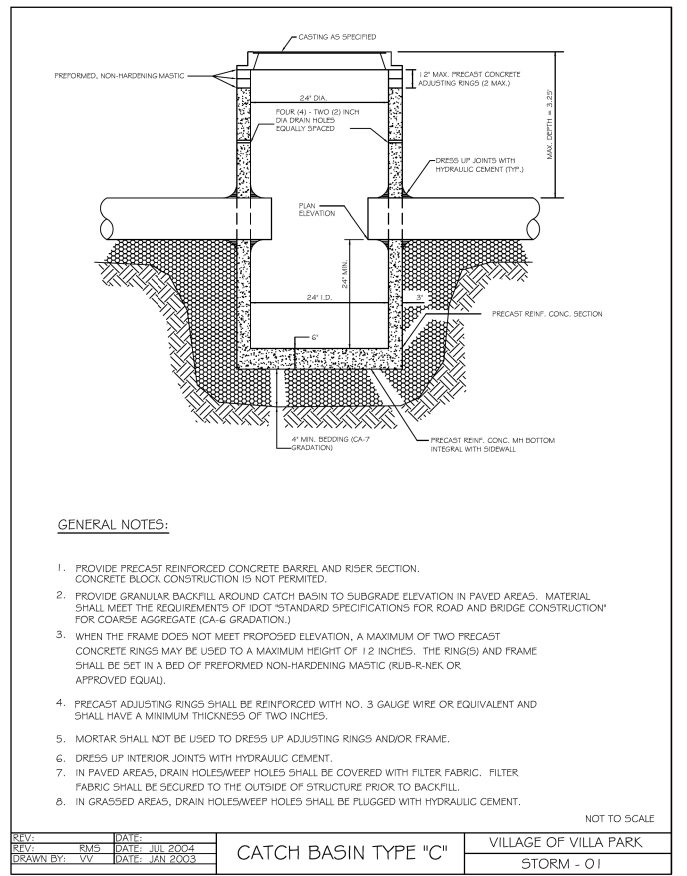
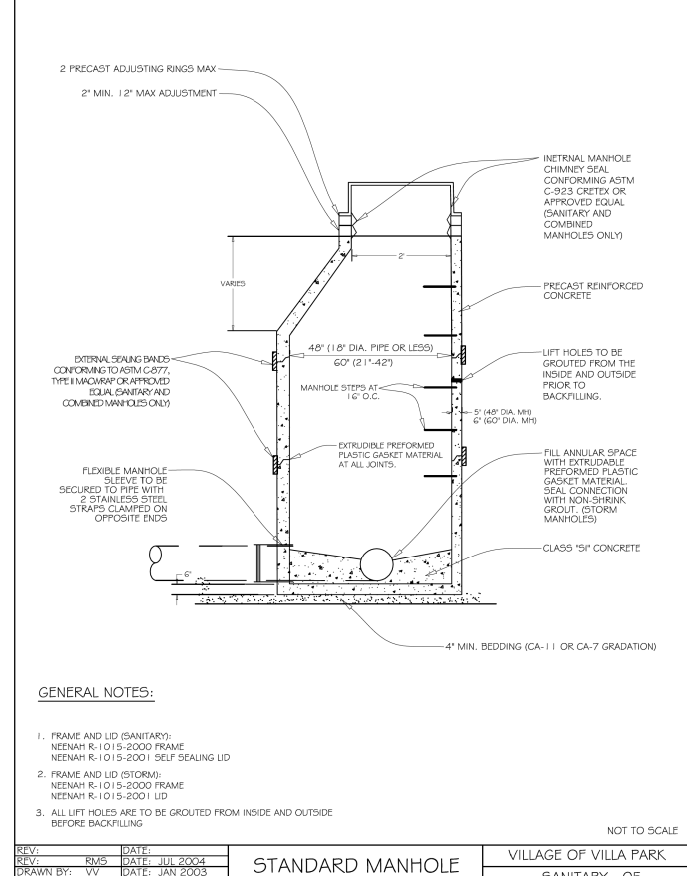
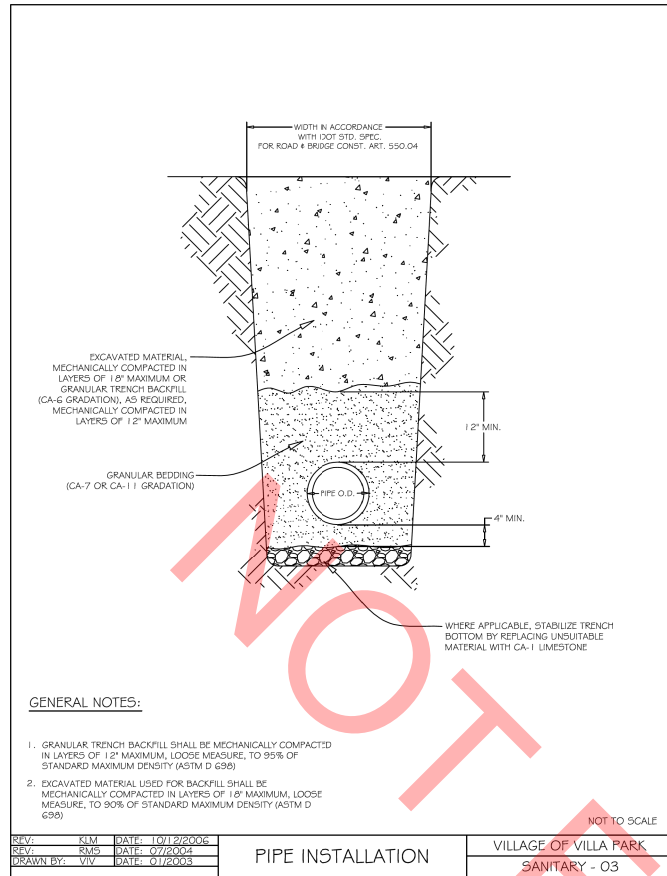
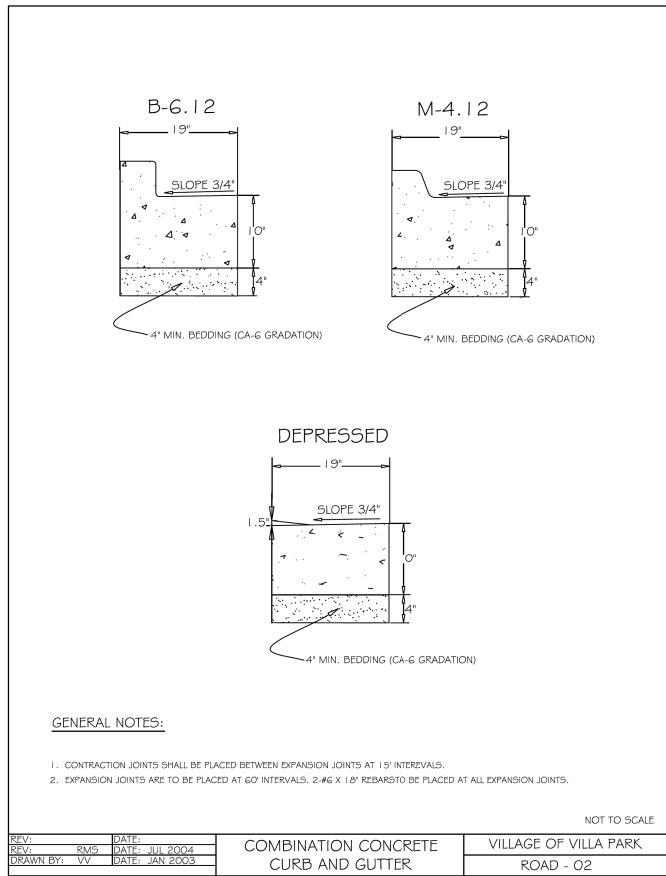

MODEL: D:\v3\100718007180_130_DCEO_H220065_Cant Projects\Drawings\Main\CADD_Sheets\107180-130-h220065.dwg
FILE NAME: 107180_130_DCEO_H220065_Cant Projects\Drawings\Main\CADD_Sheets\107180-130-h220065.dwg

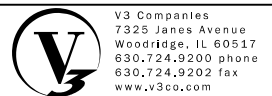

V3 Companies
7325 Janes Avenue
Woodridge, IL 60517
630.724.9200 phone
630.724.9202 fax
www.v3co.com

USER NAME = jyanich	DESIGNED - LRY	REVISED -
PLOT SCALE =	DRAWN - LRY	REVISED -
PLOT DATE = 9/25/2024	CHECKED - JDH	REVISED -
	DATE - 9/25/2024	REVISED -

DCEO DRAINAGE IMPROVEMENT PROJECT (VARIOUS LOCATIONS)

VILLA PARK	ILLINOIS	SCALE:	SHEET 1 OF 5 SHEETS	STA. TO STA.
------------	----------	--------	---------------------	--------------

CONSTRUCTION DETAILS

F.A. RTE.	SECTION	COUNTY	TOTAL SHEETS	SHEET NO.
		DUPAGE	15	11
CONTRACT NO. XXXX				
ILLINOIS	FED. AID PROJECT			

2-LANE ROADWAY

MULTI-LANE UNDIVIDED

MULTI-LANE DIVIDED WITH MEDIAN

TYPICAL LANE AND EDGE LINE MARKING

TYPICAL CROSSWALK MARKING

TYPICAL PAINTED MEDIAN MARKING

TYPICAL LEFT (OR RIGHT) TURN LANE

TYPICAL TURN LANE MARKING

COMBINATION LEFT AND U-TURN

U-TURN

LANE REDUCTION TRANSITION

TYPE OF MARKING	WIDTH OF LINE	PATTERN	COLOR	SPACING / REMARKS
CENTRELINE ON 2 LANE PAVEMENT	4 (100)	SHOP-DASH	YELLOW	10' (3.0) H LINE WITH 30' (9.1) H SPACE
CENTRELINE ON MULTI-LANE UNDIVIDED PAVEMENT	2 @ 4 (100)	SOLID	YELLOW	11 (280) C-C
NO PASSING ZONE LINES FOR ONE DIRECTION FOR BOTH DIRECTIONS	4 (100)	SOLID	YELLOW	1' (300) C-C FROM SHOP-DASH CENTRELINE 17 (430) C-C FROM MEDIAN CENTRELINE BETWEEN LANE LINES
LANE LINES	4 (100)	SHOP-DASH	WHITE	10' (3.0) H LINE WITH 30' (9.1) H SPACE
STOP LINES	4 (100)	SHOP-DASH	WHITE	SAME AS LANE LINE BEING EXTENDED
DOTTED LINES (EXTENSION OF CENTRAL LANE OR TURN LANE MARKING)	4 (100)	SHOP-DASH	WHITE	2' (600) LINE WITH 6' (1.8) H SPACE
EDGE LINES	4 (100)	SOLID	YELLOW/LEFT WHITE/RIGHT	OUTLINE MEDIANS IN YELLOW
TURN LANE MARKINGS	6 (150) LINE FULL SIZE LETTERS 6" (150) SYMBOLS 10' (3.0) H	SOLID	WHITE	SEE TYPICAL TURN LANE MARKING DETAIL
TWO WAY LEFT TURN MARKINGS	8" (200) WHITE PAINT	SHOP-DASH AND SOLID IN PAIR	YELLOW	10' (3.0) H LINE WITH 30' (9.1) H SPACE FROM SHOP-DASH 18 (450) C-C BETWEEN SOLID LINE AND SHOP-DASH LINE
CHROMIUM LINES (PEDESTRIAN)	2 @ 4 (100) @ 15' (4.5) H	SOLID	WHITE	NOT LESS THAN 6" (150) H APART 2' (600) SPACED
CHROMIUM LINES (BIKE)	2 @ 4 (100) @ 15' (4.5) H	SOLID	WHITE	NOT LESS THAN 6" (150) H APART 2' (600) SPACED
CHROMIUM LINES (SCHOOL)	2 @ 4 (100) @ 15' (4.5) H	SOLID	WHITE	NOT LESS THAN 6" (150) H APART 2' (600) SPACED
STOP LINES	24 (600)	SOLID	WHITE	PAINT 1" (25) H ABOVE OF AND PARALLEL TO CHROMIUM MARKING DETAIL. SEE TYPICAL STOP LINE MARKING DETAIL.
PAINTED MEDIANS	2 @ 4 (100) @ 15' (4.5) H	SOLID	YELLOW	11 (280) C-C FOR THE DOUBLE LINE SEE TYPICAL PAINTED MEDIAN MARKING.
DRIVE MARKING AND CHANNELING LINES	8 (200) WITH 12 (300) DIAGONALS @ 45°	SOLID	WHITE	COMMONLY: 10' (3.0) H C-C (LESS THAN 3000 (91.4) H) OR 18 (450) C-C (LESS THAN 3000 (91.4) H) OR 18 (450) C-C (COVER 4000 (121.9) H) OR 18 (450) C-C (COVER 4000 (121.9) H)
RAILROAD CROSSING	24 (600) TRANSVERSE LINES WITH 6" (150) H LETTERS "RAILROAD CROSSING" IN EACH DIRECTION 10' (3.0) H	SOLID	WHITE	SEE TYPICAL RAILROAD CROSSING MARKING DETAIL.
SHOULDER DIAGONALS (REQUIRED FOR SHOULDER 2' @ 1)	12 (300) @ 45°	SOLID	WHITE - RIGHT YELLOW - LEFT	10' (3.0) H C-C (LESS THAN 3000 (91.4) H) OR 18 (450) C-C (COVER 4000 (121.9) H) OR 18 (450) C-C (COVER 4000 (121.9) H)
U TURN ARROW	SEE DETAIL	SOLID	WHITE	30.3 (7.7)
U TURN COMBINATION LEFT AND U TURN	SEE DETAIL	SOLID	WHITE	30.3 (7.7)

FOR FURTHER DETAILS ON PAVEMENT MARKING REFER TO STANDARD SPECIFICATIONS FOR ROAD AND BRIDGE CONSTRUCTION AND STATE STANDARD DRAWINGS.

STATE OF ILLINOIS DEPARTMENT OF TRANSPORTATION

DISTRICT ONE TYPICAL PAVEMENT MARKINGS

SCALE: NONE SHEET 3 OF 2 SHEETS STA. TO STA.

ATTACHING TWO SILT FILTER FENCES (Not applicable for J-hooks)

AGGREGATE DITCH CHECK

SILT FILTER J-HOOK PLACEMENT

J-HOOK

SLICE METHOD

TRENCH METHOD

SECTION A-A

SECTION B-B

ELEVATION

SILT FILTER FENCE AS A PERIMETER EROSION BARRIER

GENERAL NOTES

The installation details and dimensions shown for perimeter erosion barriers shall also apply for inlet and pipe protection.

All dimensions are in inches (millimeters) unless otherwise shown.

DATE	REVISIONS
1-1-13	Corrected notation for flowline (E) on SEDIMENT BASIN ELEVATION
1-1-12	Omitted hay/straw perimeter barrier. Added SLICE METHOD to SECTION A-A

TEMPORARY EROSION CONTROL SYSTEMS

STANDARD 280001-07 (Sheet 1 of 2)

INLET AND PIPE PROTECTION

TYPICAL CUT CROSS-SECTION

TYPICAL FILL CROSS-SECTION

TEMPORARY DITCHES FOR CUT & FILL SECTIONS

SEDIMENT BASIN

ELEVATION

PLAN

TEMPORARY EROSION CONTROL SYSTEMS

STANDARD 280001-07 (Sheet 2 of 2)

RAMPS IN PAVED AREA SETBACK ≤ 5'

RAMPS IN UNPAVED AREA SETBACK ≤ 5'

SECTION A-A

SECTION B-B

DETAIL A

SIDE CURB DETAIL

PERPENDICULAR CURB RAMPS FOR SIDEWALKS

STANDARD 424001-11 (Sheet 1 of 2)

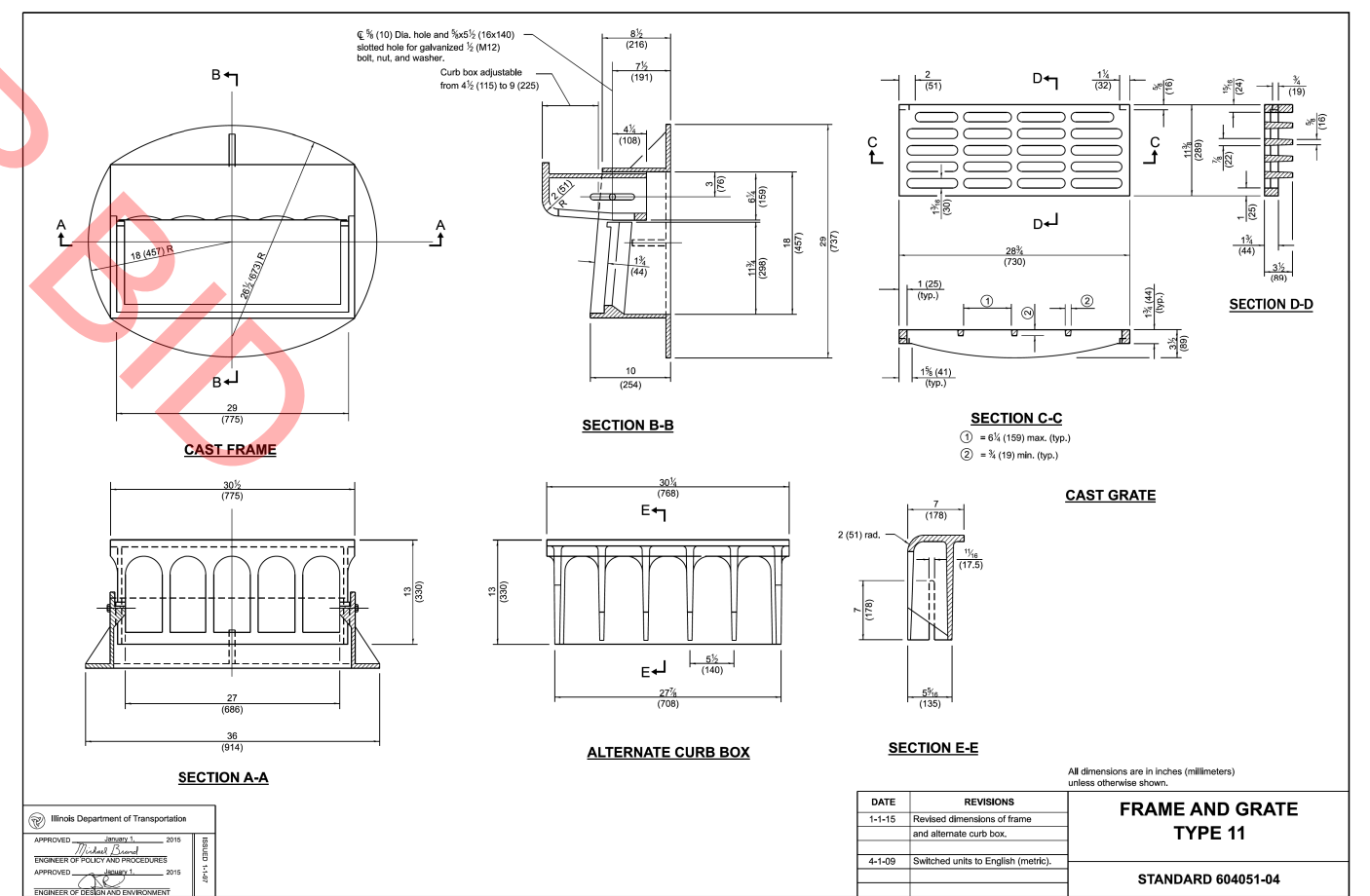
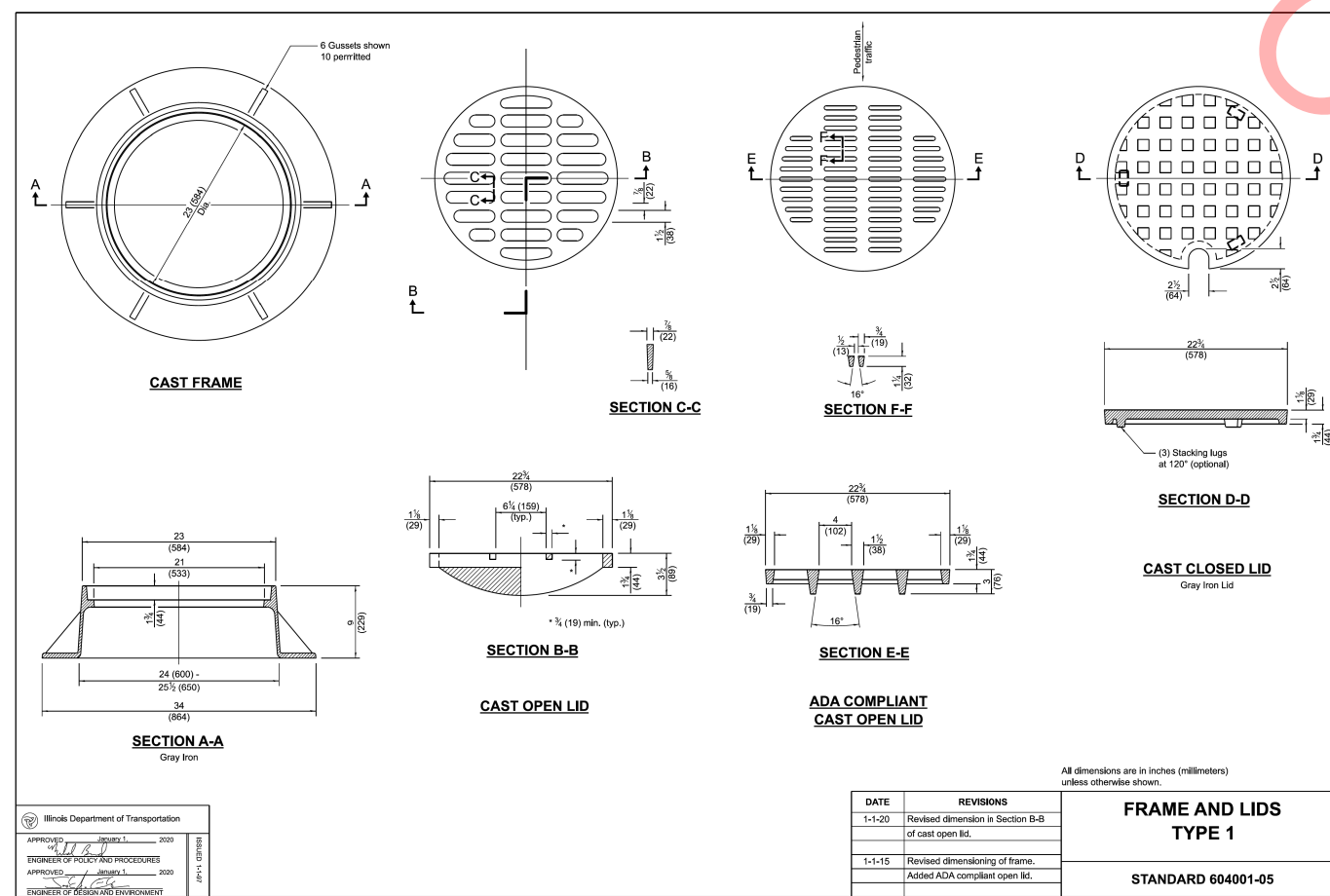
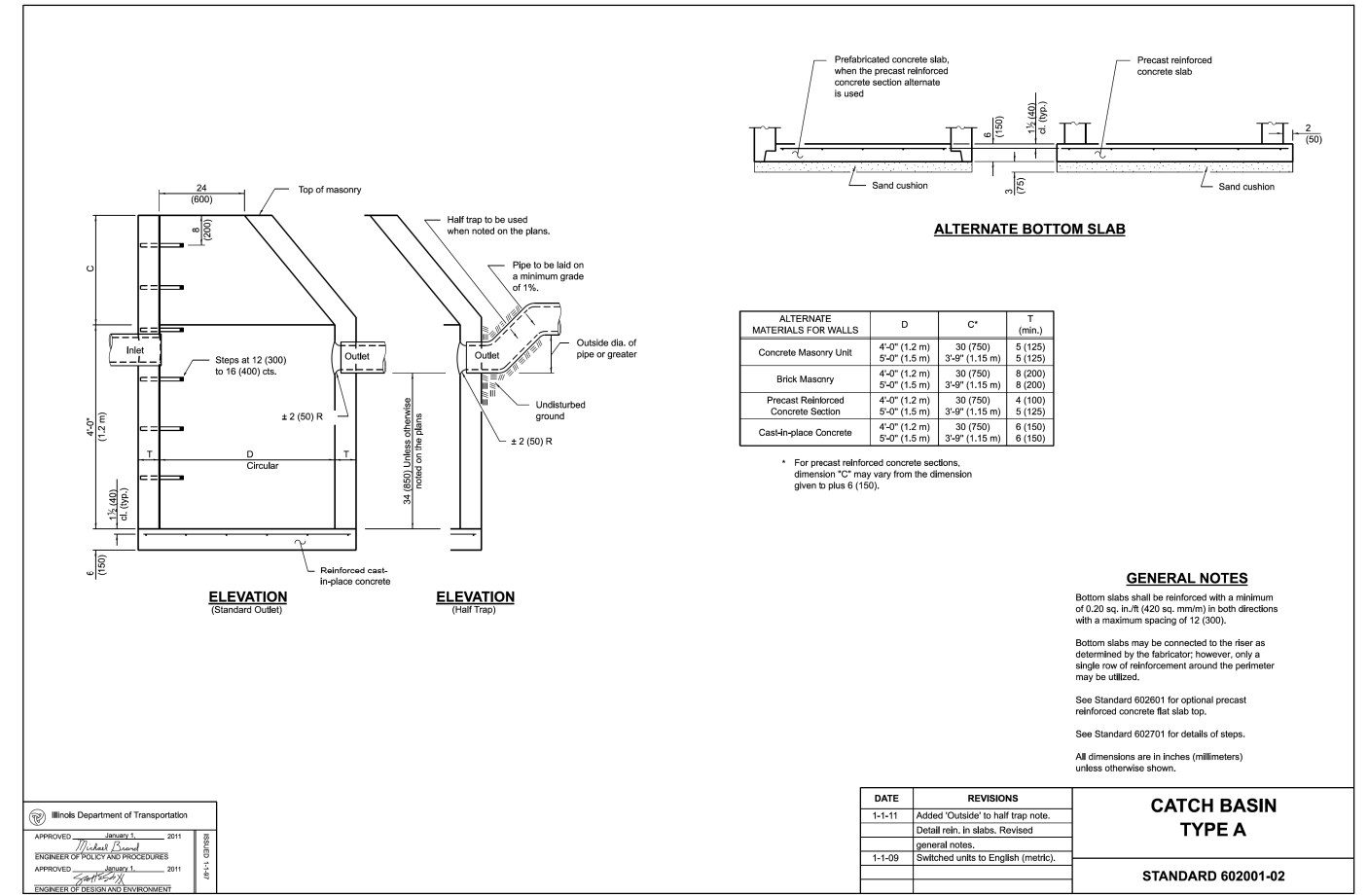
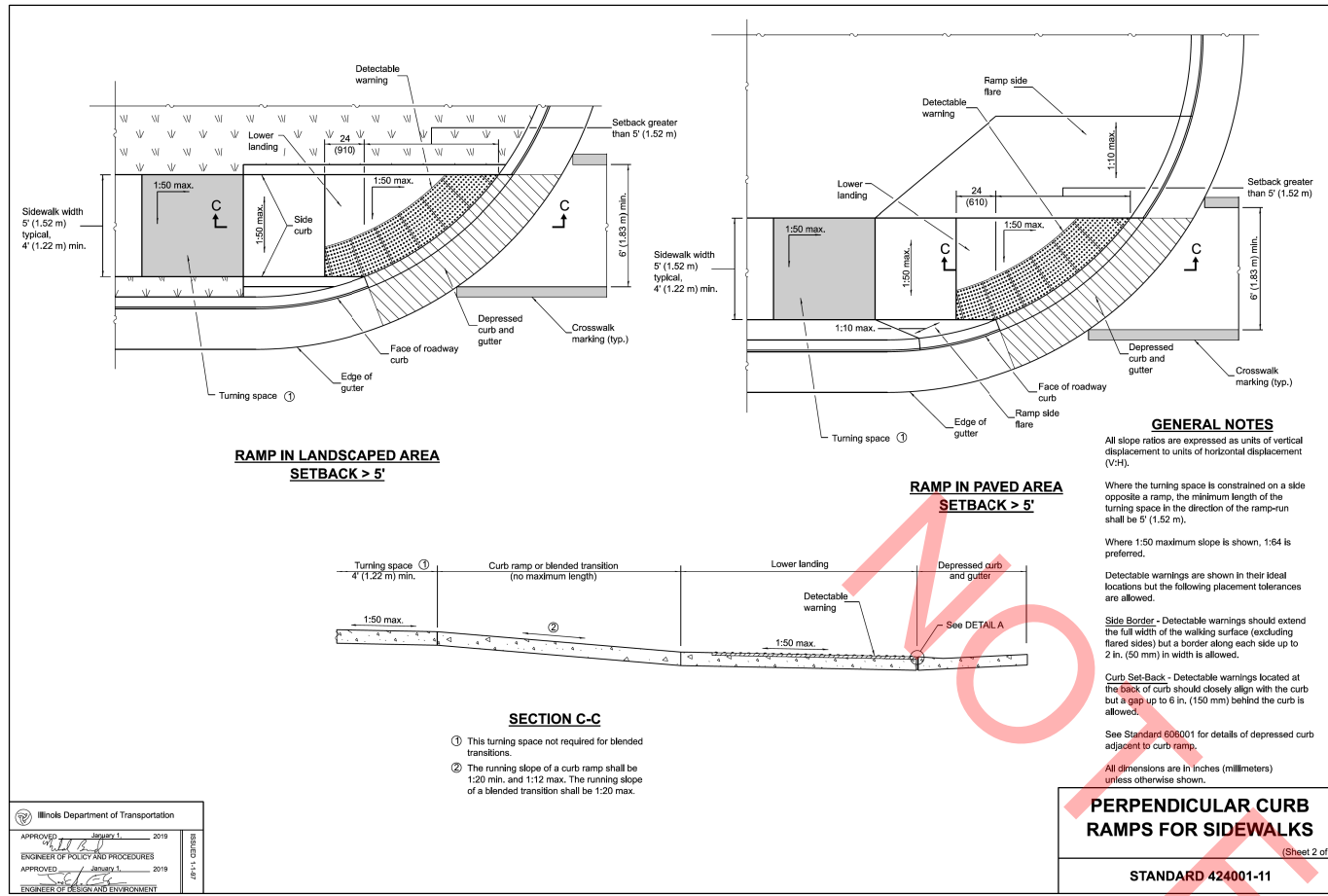

MODEL: D:\in\130 DCEO H220065 Grant Projects\Drawings\Main\CADD_Sheet\107180-10-10-10-10.dwg

V3 Companies
7325 Janes Avenue
Woodridge, IL 60517
630.724.9200 phone
630.724.9202 fax
www.v3co.com

USER NAME = lyanich	DESIGNED - LRY	REVISED -
PLOT SCALE =	DRAWN - LRY	REVISED -
PLOT DATE = 9/25/2024	CHECKED - JDH	REVISED -
	DATE - 9/25/2024	REVISED -

DCEO DRAINAGE IMPROVEMENT PROJECT (VARIOUS LOCATIONS)
VILLA PARK

ILLINOIS	SCALE:	SHEET 4 OF 5 SHEETS	STA.	TO STA.
----------	--------	---------------------	------	---------

F.A. RTE.	SECTION	COUNTY	TOTAL SHEETS	SHEET NO.
		DUPAGE	15	14
CONTRACT NO. XXXX				
ILLINOIS FED. AID PROJECT				

